



TEST REPORT

Test Report No. : UL-RPT-RP10950538JD09C V2.0

Manufacturer : Sigma Connectivity AB
Model No. : SSG-002
FCC ID : 2AFCP-002
Technology : *Bluetooth* – Low Energy
Test Standard(s) : FCC Parts 15.207, 15.209(a) & 15.247

1. This test report shall not be reproduced in full or partial, without the written approval of UL VS LTD.
2. The results in this report apply only to the sample(s) tested.
3. The sample tested is in compliance with the above standard(s).
4. The test results in this report are traceable to the national or international standards.
5. Version 2.0 supersedes all previous versions.

Date of Issue: 25 October 2016

Checked by:

Ian Watch
Senior Engineer, Radio Laboratory

Company Signatory:

Steven White
Service Lead, Radio Laboratory
UL VS LTD



This laboratory is accredited by UKAS.
The tests reported herein have been
performed in accordance with its terms
of accreditation.

The *Bluetooth*[®] word mark and logos are owned by the *Bluetooth* SIG, Inc. and any use of such marks by UL VS LTD is under licence. Other trademarks and trade names are those of their respective owners.

UL VS LTD

Pavilion A, Ashwood Park, Ashwood Way, Basingstoke, Hampshire, RG23 8BG, UK
Telephone: +44 (0)1256 312000
Facsimile: +44 (0)1256 312001

This page has been left intentionally blank.

Table of Contents

1. Customer Information.....	4
2. Summary of Testing.....	5
2.1. General Information	5
2.2. Summary of Test Results	5
2.3. Methods and Procedures	5
2.4. Deviations from the Test Specification	5
3. Equipment Under Test (EUT)	6
3.1. Identification of Equipment Under Test (EUT)	6
3.2. Description of EUT	6
3.3. Modifications Incorporated in the EUT	6
3.4. Additional Information Related to Testing	7
3.5. Support Equipment	7
4. Operation and Monitoring of the EUT during Testing	8
4.1. Operating Modes	8
4.2. Configuration and Peripherals	8
5. Measurements, Examinations and Derived Results.....	9
5.1. General Comments	9
5.2. Test Results	10
5.2.1. Transmitter AC Conducted Spurious Emissions	10
5.2.2. Transmitter Minimum 6 dB Bandwidth	13
5.2.3. Transmitter Power Spectral Density	16
5.2.4. Transmitter Maximum Peak Output Power	19
5.2.5. Transmitter Radiated Emissions	23
5.2.6. Transmitter Band Edge Radiated Emissions	31
6. Measurement Uncertainty	34
7. Report Revision History	35

1. Customer Information









Company Name:	Sigma Connectivity AB
Address:	Mobilevägen 10 223 62 Lund Sweden

2. Summary of Testing

2.1. General Information

Specification Reference:	47CFR15.247
Specification Title:	Code of Federal Regulations Volume 47 (Telecommunications): Part 15 Subpart C (Intentional Radiators) - Section 15.247
Specification Reference:	47CFR15.207 and 47CFR15.209
Specification Title:	Code of Federal Regulations Volume 47 (Telecommunications): Part 15 Subpart C (Intentional Radiators) - Sections 15.207 and 15.209
Site Registration:	209735
Location of Testing:	UL VS LTD, Unit 3 Horizon, Wade Road, Kingsland Business Park, Basingstoke, Hampshire, RG24 8AH, United Kingdom
Test Dates:	16 February 2016 to 12 October 2016

2.2. Summary of Test Results

FCC Reference (47CFR)	Measurement	Result
Part 15.207	Transmitter AC Conducted Emissions	
Part 15.247(a)(2)	Transmitter Minimum 6 dB Bandwidth	
Part 15.247(e)	Transmitter Power Spectral Density	
Part 15.247(b)(3)	Transmitter Maximum Peak Output Power	
Part 15.247(d)/15.209(a)	Transmitter Radiated Emissions	
Part 15.247(d)/15.209(a)	Transmitter Band Edge Radiated Emissions	
Key to Results		
 = Complied  = Did not comply		

2.3. Methods and Procedures

Reference:	ANSI C63.10-2013
Title:	American National Standard of Procedures for Compliance Testing of Unlicensed Wireless Devices
Reference:	KDB 558074 D01 DTS Meas Guidance v03r05, 08 April 2016
Title:	Guidance for Performing Compliance Measurements on Digital Transmission Systems (DTS) Operating Under §15.247

2.4. Deviations from the Test Specification

For the measurements contained within this test report, there were no deviations from, additions to, or exclusions from the test specification identified above.

3. Equipment Under Test (EUT)

3.1. Identification of Equipment Under Test (EUT)

Brand Name:	Sensgate
Model Name or Number:	SSG-002
Test Sample Serial Number:	01001B8D (<i>Conducted sample with RF port</i>)
Hardware Version:	Revision 2.0
Software Version:	Revision 219
FCC ID:	2AFCP-002

Brand Name:	Sensgate
Model Name or Number:	SSG-002
Test Sample Serial Number:	02001-0354 (<i>Radiated sample #1</i>)
Hardware Version:	Revision 2.0
Software Version:	Revision 219
FCC ID:	2AFCP-002

Brand Name:	Sensgate
Model Name or Number:	SSG-002
Test Sample Serial Number:	MC000170 (<i>Radiated sample #2</i>)
Hardware Version:	Revision 2.0
Software Version:	Revision 219
FCC ID:	2AFCP-002

3.2. Description of EUT

The Equipment Under Test was a gateway in the SENS BY SIGMA system, collecting data from sensors and ensuring that all component parts are continuously under full control. The gateway communicates with the sensors via *Bluetooth* and is transmitting data to the Cloud via WiFi. SensGate is designed to be mounted in the ceiling or on the wall. It contains a battery for backup and is powered via the USB port.

3.3. Modifications Incorporated in the EUT

No modifications were applied to the EUT during testing.

3.4. Additional Information Related to Testing

Technology Tested:	<i>Bluetooth</i> Low Energy (Digital Transmission System)		
Type of Unit:	Transceiver		
Channel Spacing:	2 MHz		
Modulation:	GFSK		
Data Rate:	1 Mbps		
Power Supply Requirement(s):	Nominal	3.8 VDC via 120 VAC 60 Hz	
Transmit Frequency Range:	2402 MHz to 2480 MHz		
Transmit Channels Tested:	Channel ID	RF Channel	Channel Frequency (MHz)
	Bottom	0	2402
	Middle	19	2440
	Top	39	2480

3.5. Support Equipment

The following support equipment was used to exercise the EUT during testing:

Description:	Laptop PC
Brand Name:	Hewlett Packard
Model Name or Number:	Compaq 6910p
Serial Number:	HUB7451SGN

Description:	USB Cable
Brand Name:	Not marked or stated
Model Name or Number:	Not marked or stated
Serial Number:	Not marked or stated

Description:	Switching Power Supply
Brand Name:	Phihong
Model Name or Number:	PSA05E-050Q
Serial Number:	DE29003034A1

4. Operation and Monitoring of the EUT during Testing

4.1. Operating Modes

The EUT was tested in the following operating mode(s):

- Transmitting at maximum power in *Bluetooth* LE mode with a modulated carrier, maximum data length available and Pseudorandom Bit Sequence 9.

4.2. Configuration and Peripherals

The EUT was tested in the following configuration(s):

- Controlled using a terminal application on the laptop PC supplied by the customer. The application was used to enable continuous transmission and to select the test channels as required.
- The EUT was connected to a DC power supply for all conducted tests. A USB diagnostic cable was connected to the EUT to change channels as required.
- Transmitter radiated spurious emissions tests were performed with the AC/DC power supply and USB cable connected to the EUT. The power supply input was connected to a 120 VAC 60 Hz single phase supply.
- The EUT conducted sample was used for 6 dB bandwidth, power spectral density and maximum peak output power.
- The EUT radiated samples were used for AC conducted emissions and radiated spurious emissions tests.

5. Measurements, Examinations and Derived Results

5.1. General Comments

Measurement uncertainties are evaluated in accordance with current best practice. Our reported expanded uncertainties are based on standard uncertainties, which are multiplied by an appropriate coverage factor to provide a statistical confidence level of approximately 95%. Please refer to *Section 6. Measurement Uncertainty* for details.

In accordance with UKAS requirements all the measurement equipment is on a calibration schedule. All equipment was within the calibration period on the date of testing.

5.2. Test Results

5.2.1. Transmitter AC Conducted Spurious Emissions

Test Summary:

Test Engineer:	Matthew Galbraith	Test Date:	07 October 2016
Test Sample Serial Number:	MC000170		

FCC Reference:	Part 15.207
Test Method Used:	ANSI C63.10 Section 6.2

Environmental Conditions:

Temperature (°C):	22
Relative Humidity (%):	43

Note(s):

1. The EUT was connected to an AC/DC power supply via USB cable. The AC/DC power supply input was connected to a 120 VAC 60 Hz single phase supply via a LISN.
2. Pre-scans were initially performed on all supported technologies/modes and found to produce identical results. Final measurements were therefore only performed on one test case on frequencies that resulted in the highest live/neutral levels and the results entered into the tables below.
3. A pulse limiter was fitted between the LISN and the test receiver.

Test setup:

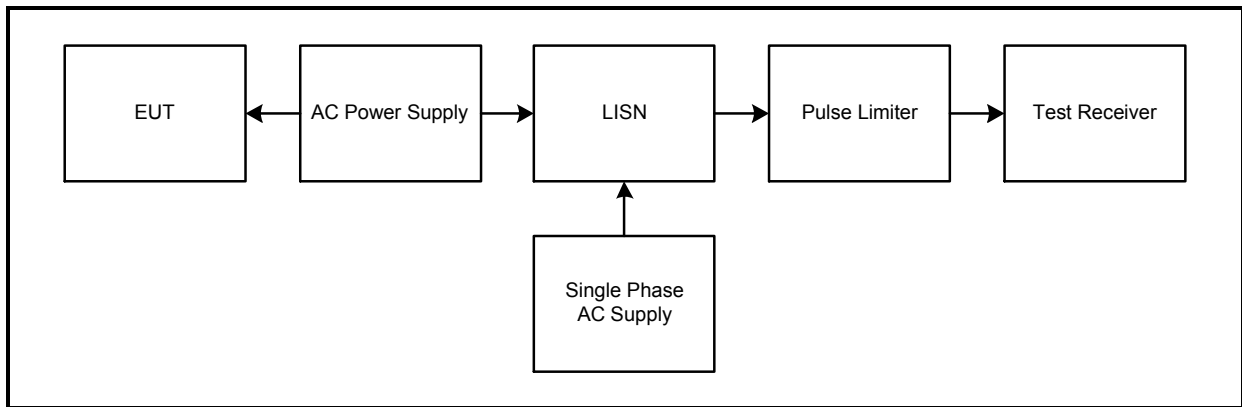

Transmitter AC Conducted Spurious Emissions (continued)**Results: Live / Quasi Peak**

Frequency (MHz)	Line	Level (dB μ V)	Limit (dB μ V)	Margin (dB)	Result
0.190500	Live	47.4	64.0	16.6	Complied
0.235500	Live	44.9	62.3	17.4	Complied
0.289500	Live	38.9	60.5	21.6	Complied
2.566500	Live	34.1	56.0	21.9	Complied
3.588000	Live	36.1	56.0	19.9	Complied
4.434000	Live	36.1	56.0	19.9	Complied

Results: Live / Average

Frequency (MHz)	Line	Level (dB μ V)	Limit (dB μ V)	Margin (dB)	Result
0.186000	Live	34.3	54.2	19.9	Complied
0.190500	Live	31.7	54.0	22.3	Complied
0.424500	Live	31.6	47.4	15.8	Complied
0.424500	Live	31.6	47.4	15.8	Complied
1.513500	Live	21.8	46.0	24.2	Complied
3.507000	Live	25.2	46.0	20.8	Complied

Results: Neutral / Quasi Peak

Frequency (MHz)	Line	Level (dB μ V)	Limit (dB μ V)	Margin (dB)	Result
0.190500	Neutral	43.7	64.0	20.3	Complied
0.235500	Neutral	42.6	62.3	19.7	Complied
0.379500	Neutral	40.6	58.3	17.7	Complied
0.469500	Neutral	37.3	56.5	19.2	Complied
1.374000	Neutral	36.6	56.0	19.4	Complied
2.368500	Neutral	36.7	56.0	19.3	Complied

Results: Neutral / Average

Frequency (MHz)	Line	Level (dB μ V)	Limit (dB μ V)	Margin (dB)	Result
0.379500	Neutral	37.6	48.3	10.7	Complied
0.474000	Neutral	37.4	46.4	9.0	Complied
0.852000	Neutral	35.6	46.0	10.4	Complied
0.852000	Neutral	33.3	46.0	12.7	Complied
1.324500	Neutral	32.5	46.0	13.5	Complied
1.846500	Neutral	32.5	46.0	13.5	Complied

Transmitter AC Conducted Spurious Emissions (continued)

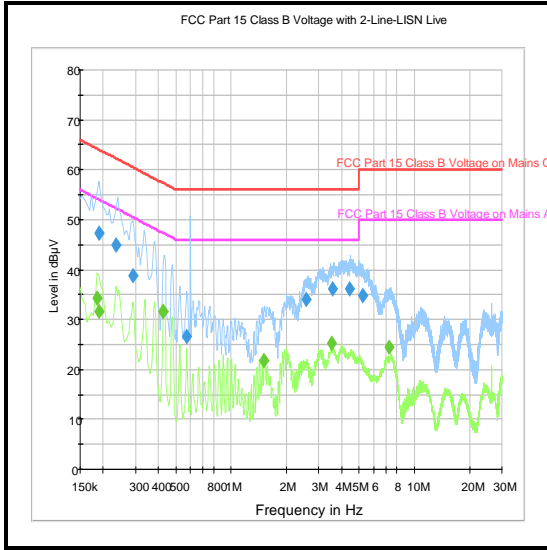

Live

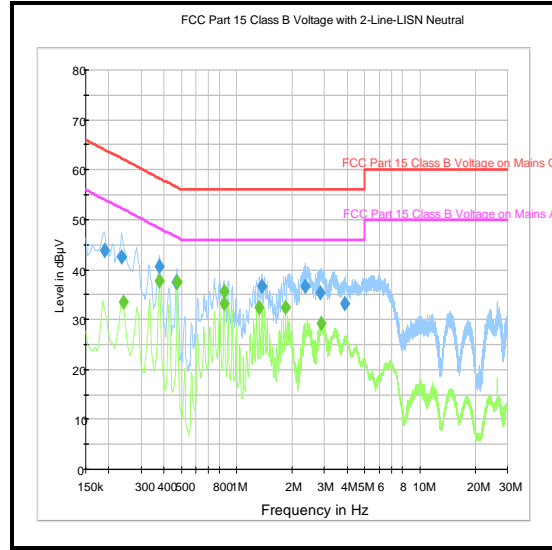

Neutral

Note: These plots are pre-scans and for indication purposes only. For final measurements, see accompanying tables.

Test Equipment Used:

Asset No.	Instrument	Manufacturer	Type No.	Serial No.	Date Calibration Due	Cal. Interval (Months)
M2015	Thermohygrometer	Testo	608-H1	45046424	10 Jun 2017	12
A649	LISN	Rohde & Schwarz	ESH3-Z5	825562/008	09 Aug 2017	12
A1830	Pulse Limiter	Rohde & Schwarz	ESH3-Z2	100668	08 Mar 2017	12
M1379	Test Receiver	Rohde & Schwarz	ESIB7	100330	15 Dec 2016	12

5.2.2. Transmitter Minimum 6 dB Bandwidth

Test Summary:

Test Engineer:	Stefan Ho	Test Date:	12 October 2016
Test Sample Serial Number:	01001B8D		

FCC Reference:	Part 15.247(a)(2)
Test Method Used:	FCC KDB 558074 Section 8.1 Option 1

Environmental Conditions:

Temperature (°C):	25
Relative Humidity (%):	38

Note(s):

1. 6 dB DTS bandwidth tests were performed using a signal analyser in accordance with FCC KDB 558074 Section 8.1 Option 1 measurement procedure. The signal analyser resolution bandwidth was set to 100 kHz and video bandwidth 300 kHz. A peak detector was used, sweep time was set to auto and the trace mode was Max Hold. The DTS bandwidth was measured at 6 dB down from the peak of the signal.
2. The signal analyser was connected to the RF port on the EUT using suitable attenuation and RF cable.

Test setup:

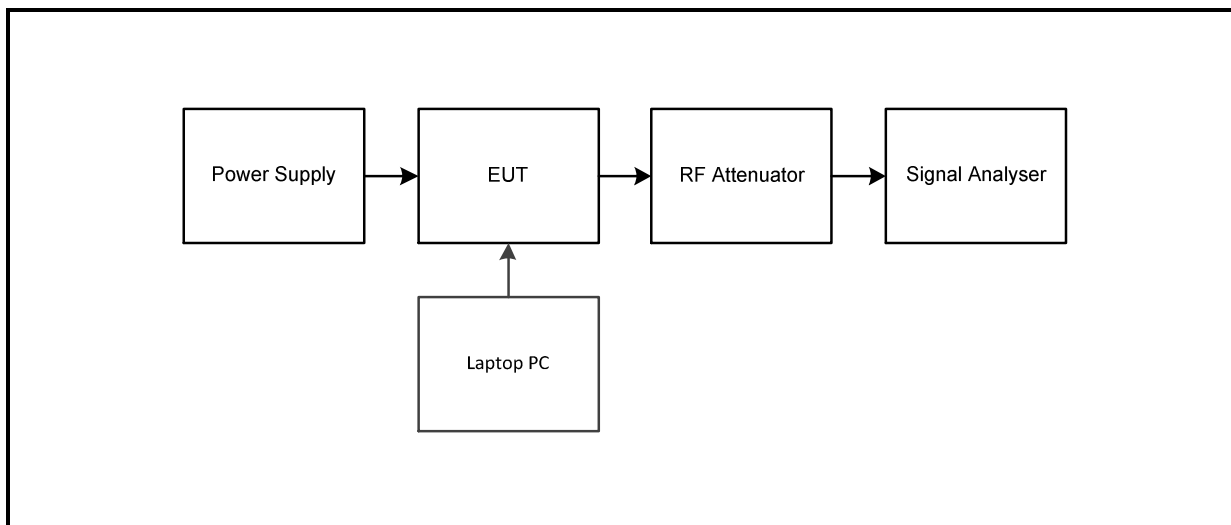

Transmitter Minimum 6 dB Bandwidth (continued)

Results:

Channel	6 dB Bandwidth (kHz)	Limit (kHz)	Margin (kHz)	Result
Bottom	717.800	≥500	217.800	Complied
Middle	717.800	≥500	217.800	Complied
Top	723.600	≥500	223.600	Complied

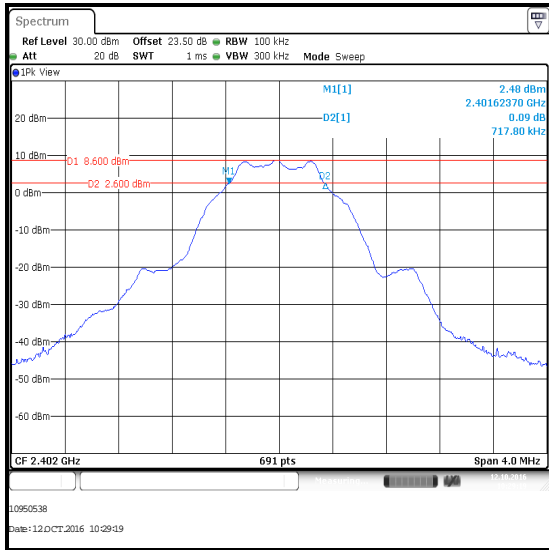

Bottom Channel

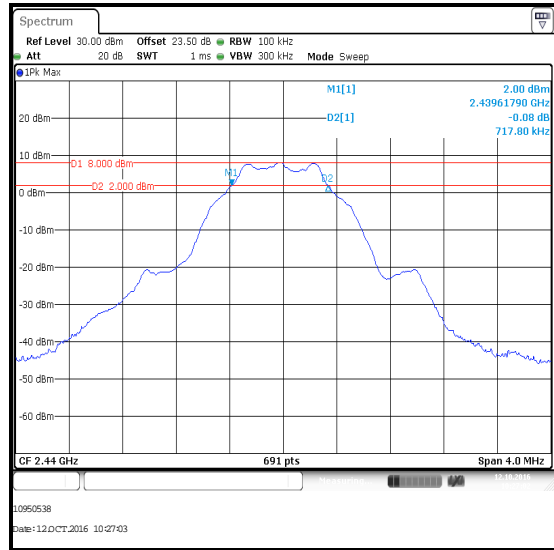

Middle Channel

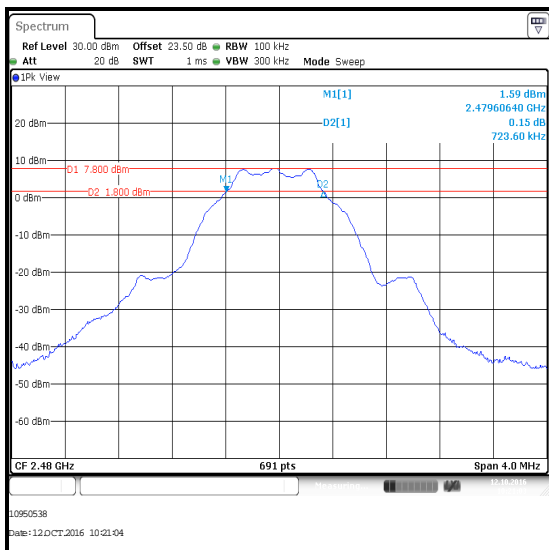

Top Channel

Transmitter Minimum 6 dB Bandwidth (continued)**Test Equipment Used:**

Asset No.	Instrument	Manufacturer	Type No.	Serial No.	Date Calibration Due	Cal. Interval (Months)
M1873	Signal Analyser	Rohde & Schwarz	FSV30	103074	27 Jun 2017	12
A2500	Directional Coupler	AtlanTecRF	CDC-003060-10	13122501835	Calibrated before use	-
A2526	Attenuator	AtlanTecRF	AN18W5-20	832828#1	Calibrated before use	-
S0562	DC power supply	Thurlby Thandar Instruments	PL330QMD	054895	Calibrated before use	-
M1269	Multimeter	Fluke	179	90250210	13 May 2017	12
M2002	Thermohygrometer	Testo	608-H1	45041825	02 Apr 2017	12

5.2.3. Transmitter Power Spectral Density**Test Summary:**

Test Engineer:	Stefan Ho	Test Date:	12 October 2016
Test Sample Serial Number:	01001B8D		

FCC Reference:	Part 15.247(e)
Test Method Used:	FCC KDB 558074 Section 10.2

Environmental Conditions:

Temperature (°C):	25
Relative Humidity (%):	38

Note(s):

1. Transmitter Power Spectral Density tests were performed using a signal analyser in accordance with FCC KDB 558074 Section 10.2.
2. The signal analyser resolution bandwidth was set to 30 kHz and video bandwidth of 100 kHz. A peak detector was used, sweep time was set to auto and trace mode was Max Hold. The span was set to 1.5 times the measured DTS bandwidth. A marker was placed at the peak of the signal and the results recorded in the table below.
3. The signal analyser was connected to the RF port on the EUT using suitable attenuation and RF cable. An RF level offset was entered on the signal analyser to compensate for the loss of the attenuator and RF cable.

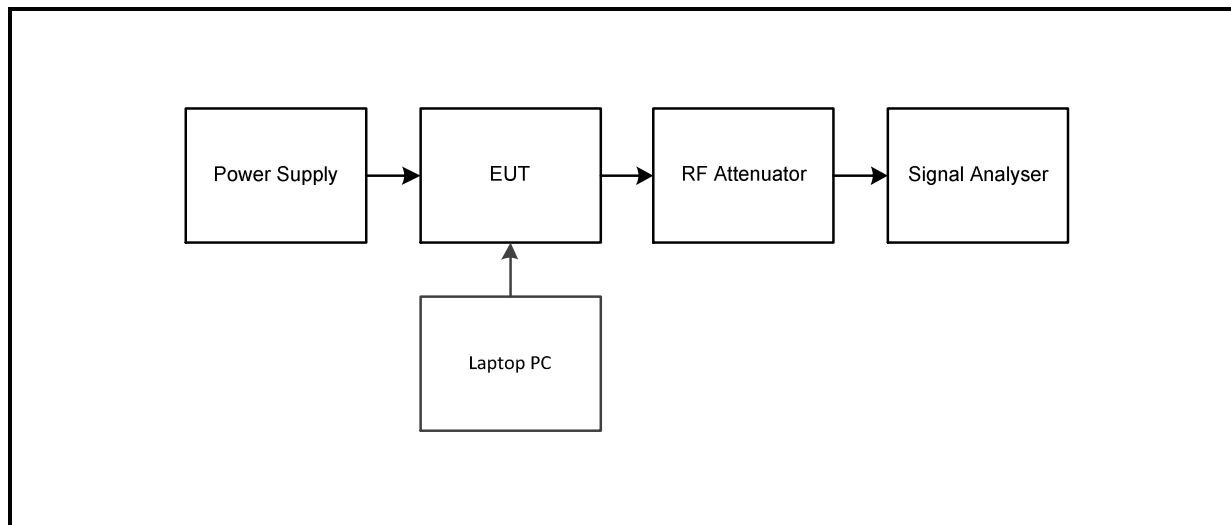
Test setup:

Transmitter Power Spectral Density (continued)

Results:

Channel	Output Power (dBm / 3 kHz)	Limit (dBm / 3 kHz)	Margin (dB)	Result
Bottom	6.8	8.0	1.2	Complied
Middle	6.2	8.0	1.8	Complied
Top	6.1	8.0	1.9	Complied

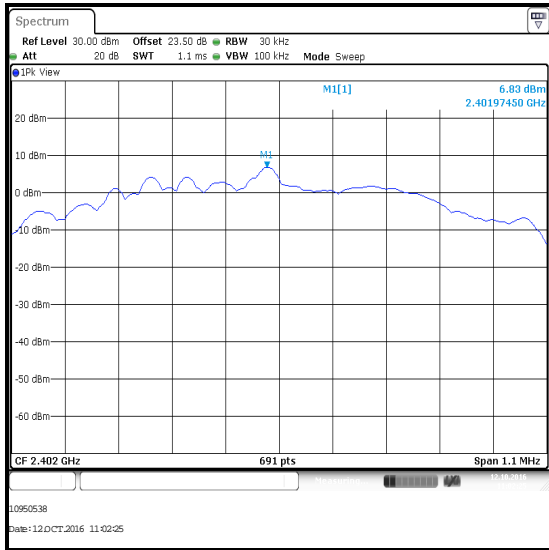

Bottom Channel

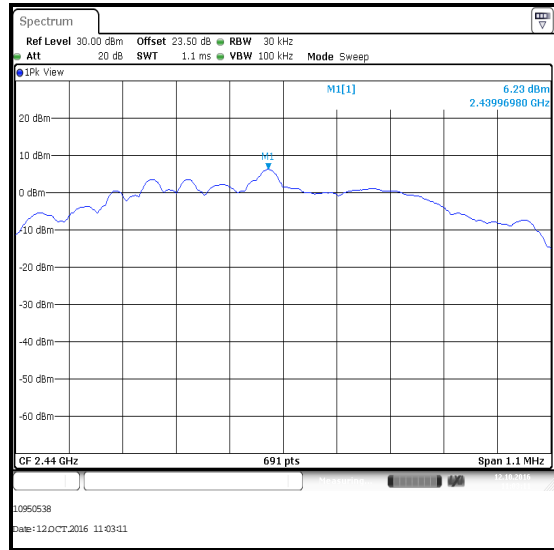

Middle Channel

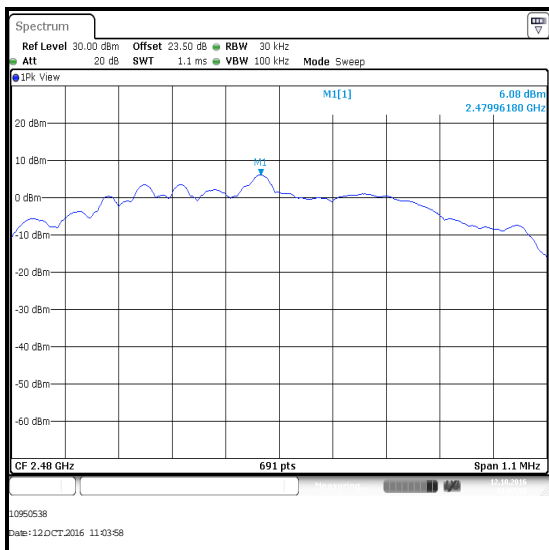

Top Channel

Transmitter Power Spectral Density (continued)**Test Equipment Used:**

Asset No.	Instrument	Manufacturer	Type No.	Serial No.	Date Calibration Due	Cal. Interval (Months)
M1873	Signal Analyser	Rohde & Schwarz	FSV30	103074	27 Jun 2017	12
A2500	Directional Coupler	AtlanTecRF	CDC-003060-10	13122501835	Calibrated before use	-
A2526	Attenuator	AtlanTecRF	AN18W5-20	832828#1	Calibrated before use	-
G0607	Signal Generator	Rohde & Schwarz	SMU200A	100943	10 May 2019	36
M199	Power Meter	Rohde & Schwarz	NRVS	827023/075	11 Apr 2018	24
M1267	Thermal Power Sensor	Rohde & Schwarz	NRV-Z52	100155	15 Apr 2018	24
S0562	DC power supply	Thurlby Thandar Instruments	PL330QMD	054895	Calibrated before use	-
M1269	Multimeter	Fluke	179	90250210	13 May 2017	12
M2002	Thermohygrometer	Testo	608-H1	45041825	02 Apr 2017	12

5.2.4. Transmitter Maximum Peak Output Power

Test Summary:

Test Engineer:	Stefan Ho	Test Date:	12 October 2016
Test Sample Serial Number:	01001B8D		

FCC Reference:	Part 15.247(b)(3)
Test Method Used:	FCC KDB 558074 Section 9.1.1

Environmental Conditions:

Temperature (°C):	25
Relative Humidity (%):	38

Note(s):

1. Conducted power tests were performed using a signal analyser in accordance with FCC KDB 558074 Section 9.1.1 with the RBW > DTS bandwidth procedure. A resolution bandwidth of 1 MHz was used and the video bandwidth was set to 3 MHz.
2. The signal analyser was connected to the RF port on the EUT using suitable attenuation and RF cable. An RF level offset was entered on the signal analyser to compensate for the loss of the attenuator and RF cable.
3. The conducted power was added to the declared antenna gain to obtain the EIRP.

Test setup:

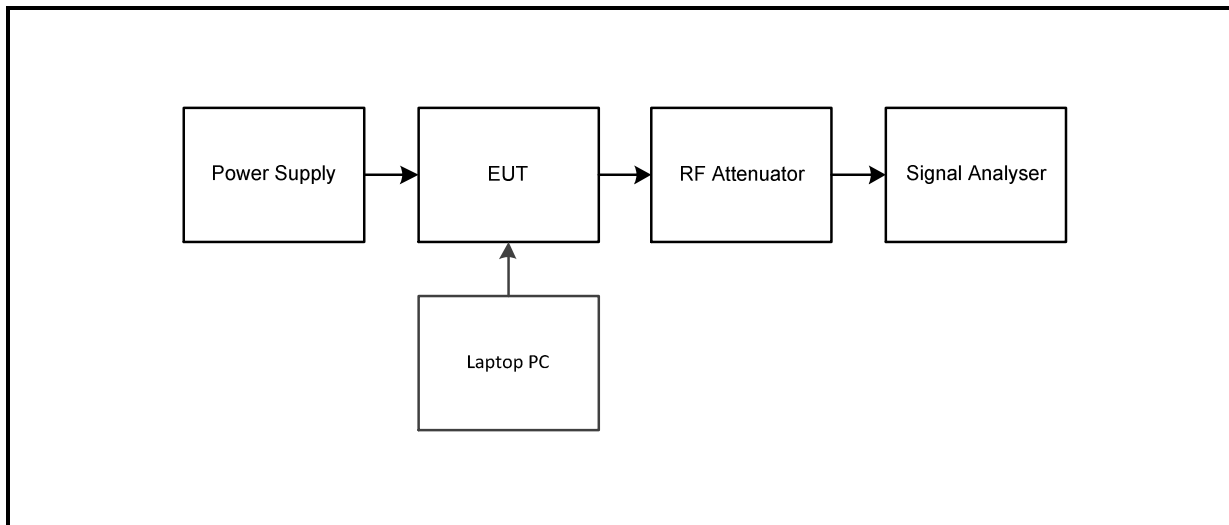

Transmitter Maximum Peak Output Power (continued)**Results:**

Channel	Conducted Peak Power (dBm)	Conducted Peak Power Limit (dBm)	Margin (dB)	Result
Bottom	9.3	30.0	20.7	Complied
Middle	8.7	30.0	21.3	Complied
Top	8.6	30.0	21.4	Complied

Channel	Conducted Peak Power (dBm)	Declared Antenna Gain (dBi)	EIRP (dBm)	De Facto EIRP Limit (dBm)	Margin (dB)	Result
Bottom	9.3	2.0	11.3	36.0	24.7	Complied
Middle	8.7	2.0	10.7	36.0	25.3	Complied
Top	8.6	2.0	10.6	36.0	25.4	Complied

Transmitter Maximum Peak Output Power (continued)

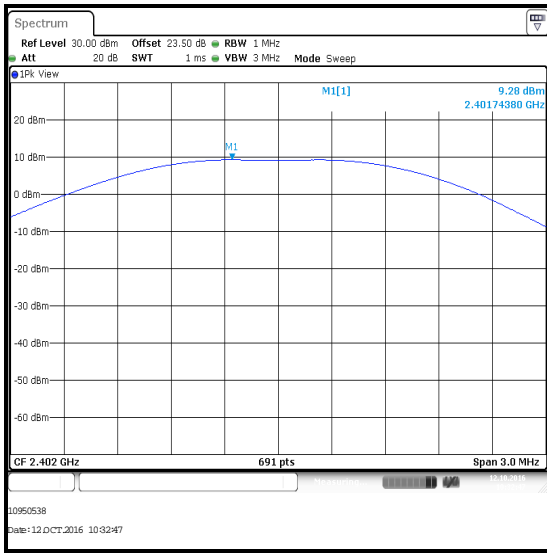

Bottom Channel

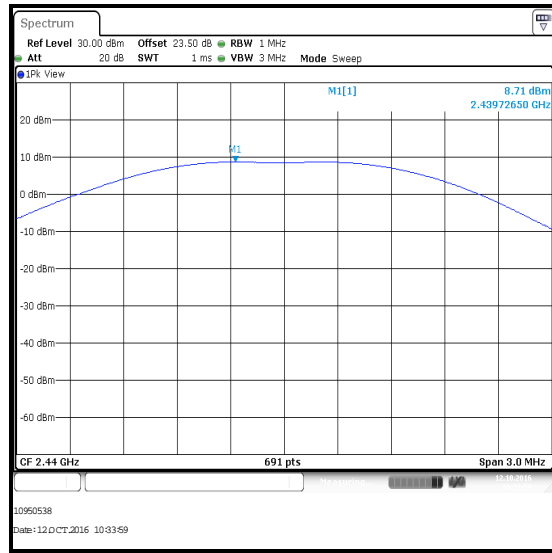

Middle Channel

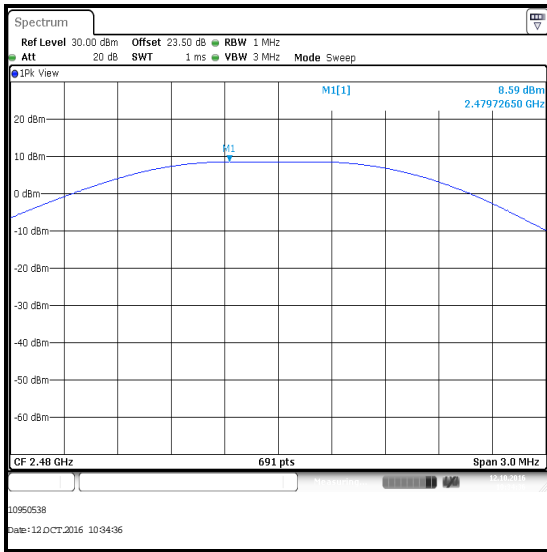

Top Channel

Transmitter Maximum Peak Output Power (continued)**Test Equipment Used:**

Asset No.	Instrument	Manufacturer	Type No.	Serial No.	Date Calibration Due	Cal. Interval (Months)
M1873	Signal Analyser	Rohde & Schwarz	FSV30	103074	27 Jun 2017	12
A2500	Directional Coupler	AtlanTecRF	CDC-003060-10	13122501835	Calibrated before use	-
A2526	Attenuator	AtlanTecRF	AN18W5-20	832828#1	Calibrated before use	-
G0607	Signal Generator	Rohde & Schwarz	SMU200A	100943	10 May 2019	36
M199	Power Meter	Rohde & Schwarz	NRVS	827023/075	11 Apr 2018	24
M1267	Thermal Power Sensor	Rohde & Schwarz	NRV-Z52	100155	15 Apr 2018	24
S0562	DC power supply	Thurlby Thandar Instruments	PL330QMD	054895	Calibrated before use	-
M1269	Multimeter	Fluke	179	90250210	13 May 2017	12
M2002	Thermohygrometer	Testo	608-H1	45041825	02 Apr 2017	12

5.2.5. Transmitter Radiated Emissions**Test Summary:**

Test Engineer:	Nick Steele	Test Date:	09 March 2016
Test Sample Serial Number:	02001-0354		

FCC Reference:	Parts 15.247(d) & 15.209(a)
Test Method Used:	ANSI C63.10 Sections 6.3 and 6.5
Frequency Range	30 MHz to 1000 MHz

Environmental Conditions:

Temperature (°C):	24
Relative Humidity (%):	31

Note(s):

1. The final measured value, for the given emission, in the table below incorporates the calibrated antenna factor and cable loss.
2. The preliminary scans showed similar emission levels below 1 GHz, for each channel of operation. Therefore final radiated emissions measurements were performed with the EUT set to the middle channel only.
3. All other emissions shown on the pre-scans were investigated and found to be ambient, or > 20 dB below the appropriate limit or below the noise floor of the measurement system.
4. Measurements below 1 GHz were performed in a semi-anechoic chamber (Asset Number K0001) at a distance of 3 metres. The EUT was placed at a height of 80 cm above the reference ground plane in the centre of the chamber turntable. Maximum emission levels were determined by height searching the measurement antenna over the range 1 metre to 4 metres.

Transmitter Radiated Emissions (continued)

Test setup for radiated measurements:

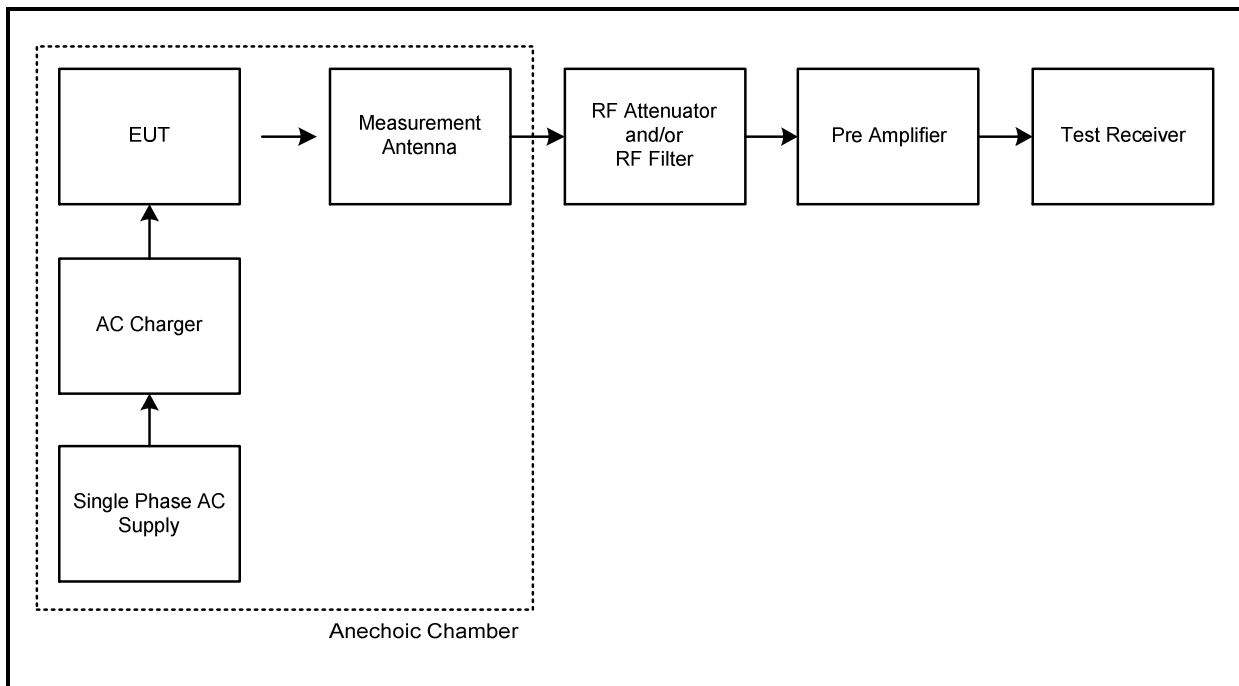
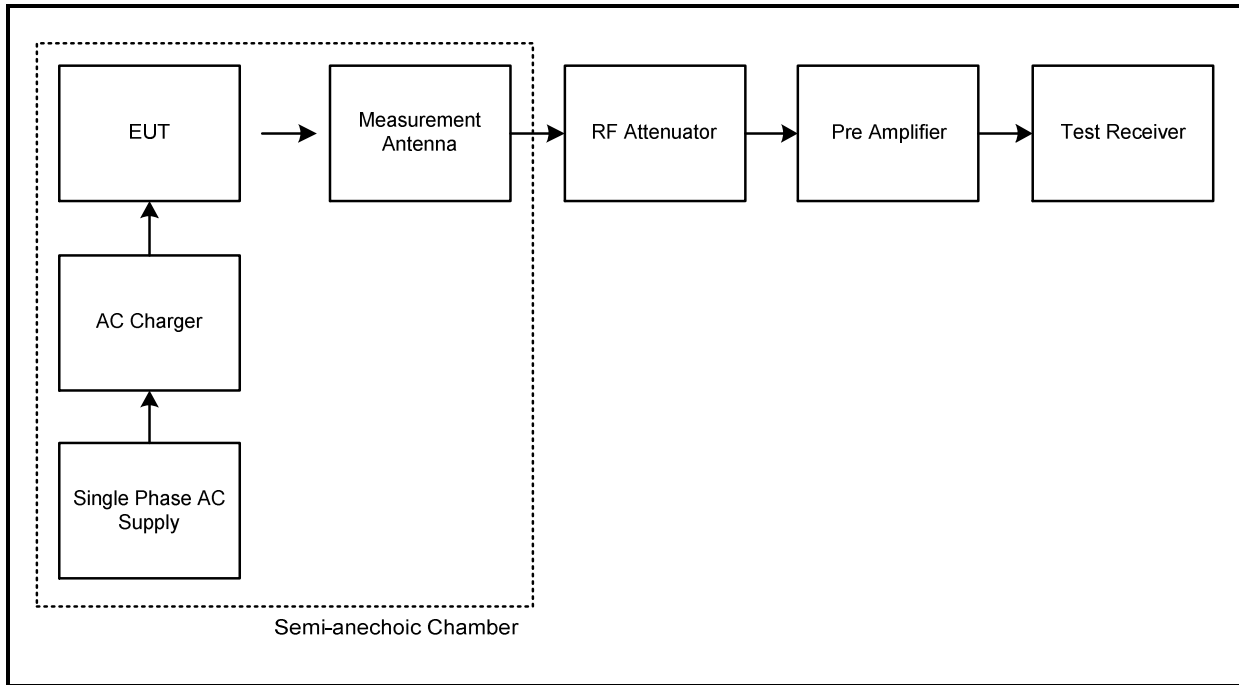

Transmitter Radiated Emissions (continued)

Results: Middle Channel

Frequency (MHz)	Antenna Polarity	Level (dB μ V/m)	Limit (dB μ V/m)	Margin (dB)	Result
266.541	Horizontal	29.5	46.0	16.5	Complied
268.746	Horizontal	29.3	46.0	16.7	Complied
279.599	Horizontal	30.3	46.0	15.7	Complied

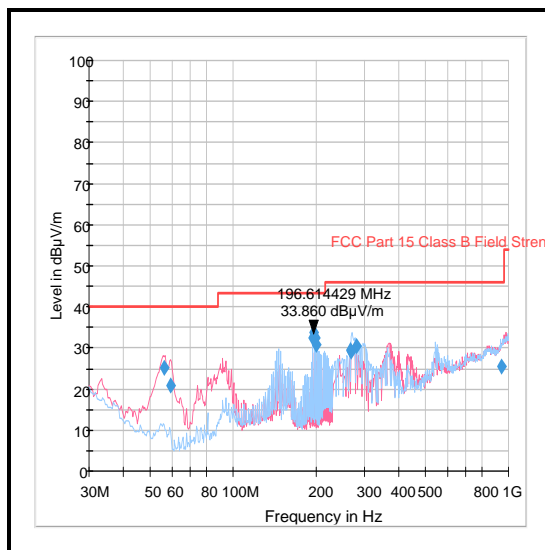

Note: This plot is a pre-scan and for indication purposes only. For final measurements, see accompanying table.

Test Equipment Used:

Asset No.	Instrument	Manufacturer	Type No.	Serial No.	Date Calibration Due	Cal. Interval (Months)
M1627	Thermohygrometer	JM Handelspunkt	30.5015.10	Not stated	11 Jan 2017	12
K0001	5 m RSE Chamber	Rainford EMC	N/A	N/A	19 Mar 2016	12
M1273	Test Receiver	Rohde & Schwarz	ESIB26	100275	19 Mar 2016	12
A259	Antenna	Chase	CBL6111A	1513	09 Apr 2016	12
G0543	Amplifier	Sonoma	310N	230801	28 Feb 2017	12
A1834	Attenuator	Hewlett Packard	8491B	10444	28 Feb 2017	12

Transmitter Radiated Emissions (continued)**Test Summary:**

Test Engineer:	David Doyle	Test Date:	16 February 2016
Test Sample Serial Number:	02001-0354		

FCC Reference:	Parts 15.247(d) & 15.209(a)
Test Method Used:	FCC KDB 558074 Sections 11 & 12 referencing ANSI C63.10 Sections 6.3 & 6.6
Frequency Range	1 GHz to 25 GHz

Environmental Conditions:

Temperature (°C):	23
Relative Humidity (%):	31

Note(s):

1. The final measured value, for the given emission, in the table below incorporates the calibrated antenna factor and cable loss.
2. All other emissions shown on the pre-scan plot were investigated and found to be ambient or >20 dB below the applicable limit or below the measurement system noise floor.
3. The emission shown on the 1 GHz to 4 GHz plot is the EUT fundamental.
4. Pre-scans above 1 GHz were performed in a fully anechoic chamber (Asset Number K0002) at a distance of 3 metres. The EUT was placed at a height of 1.5 metres above the test chamber floor in the centre of the chamber turntable. All measurement antennas were placed at a fixed height of 1.5 metres above the test chamber floor, in line with the EUT. Final measurements above 1 GHz were performed in a semi-anechoic chamber (Asset Number K0001) at a distance of 3 metres. The EUT was placed at a height of 1.5 metres above the reference ground plane in the centre of the chamber turntable. Maximum emission levels were determined by height searching the measurement antenna over the range 1 metre to 4 metres.
5. Pre-scans were performed and a marker placed on the highest measured level of the appropriate plot. The test receiver resolution bandwidth was set to 1 MHz and video bandwidth 3 MHz. The sweep time was set to auto.
6. In accordance with ANSI C63.10 Section 6.6.4.3, Note 1, if the peak measured value complies with the average limit, it is unnecessary to perform an average measurement.

Transmitter Radiated Emissions (continued)**Results: Peak / Bottom Channel**

Frequency (MHz)	Antenna Polarity	Peak Level (dB μ V/m)	Average Limit (dB μ V/m)	Margin (dB)	Result
4804.598	Vertical	47.2	54.0	6.8	Complied

Results: Peak / Middle Channel

Frequency (MHz)	Antenna Polarity	Peak Level (dB μ V/m)	Average Limit (dB μ V/m)	Margin (dB)	Result
4879.551	Vertical	47.7	54.0	6.3	Complied

Results: Peak / Top Channel

Frequency (MHz)	Antenna Polarity	Peak Level (dB μ V/m)	Average Limit (dB μ V/m)	Margin (dB)	Result
4959.484	Vertical	47.8	54.0	6.2	Complied

Transmitter Radiated Emissions (continued)

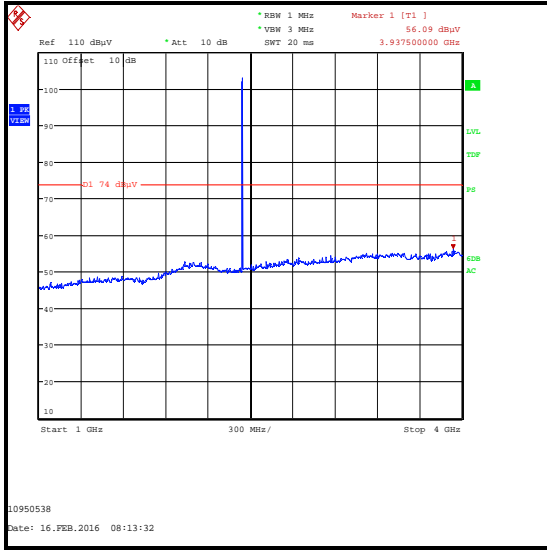

Peak Detector

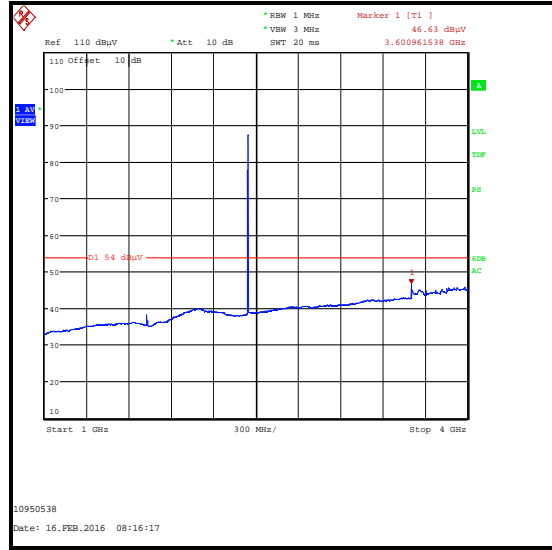

Average Detector

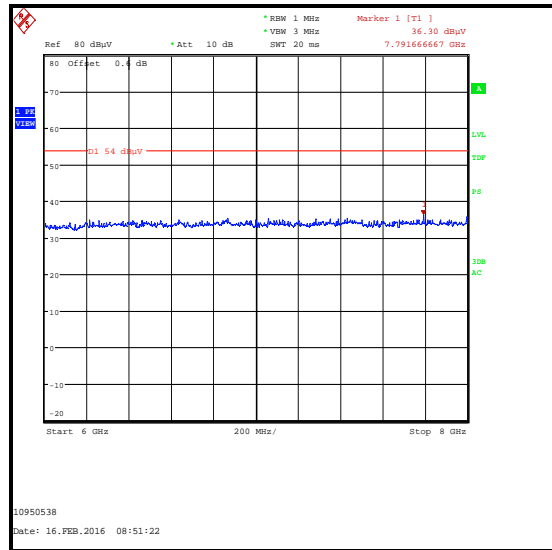
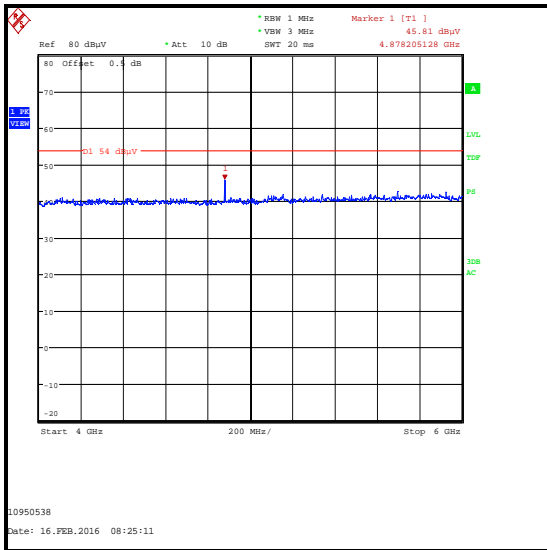

Transmitter Radiated Emissions (continued)

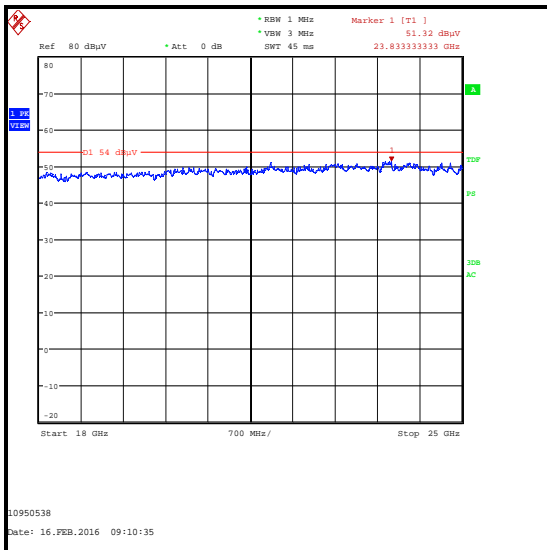
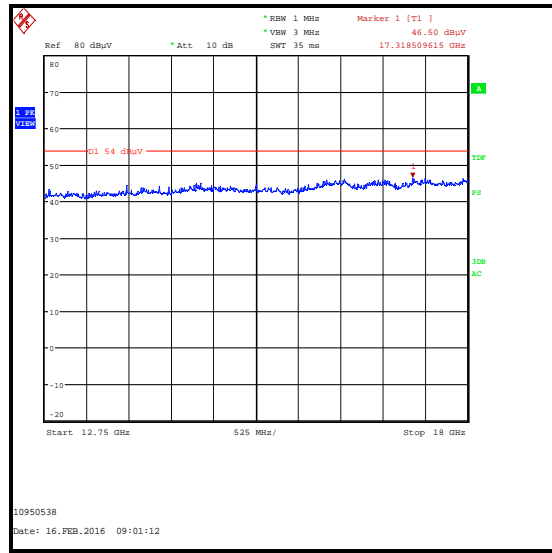
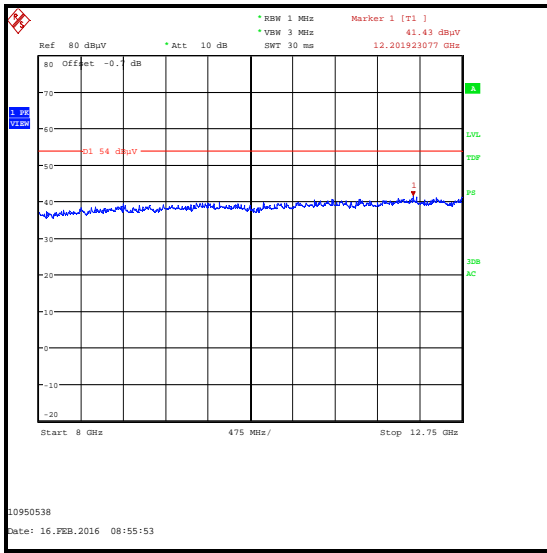

Note: These plots are pre-scans and for indication purposes only. For final measurements, see accompanying tables.

Transmitter Radiated Emissions (continued)**Test Equipment Used:**

Asset No.	Instrument	Manufacturer	Type No.	Serial No.	Date Calibration Due	Cal. Interval (Months)
M1656	Thermohygrometer	JM Handelspunkt	30.5015.13	None stated	23 Apr 2016	12
K0002	3m RSE Chamber	Rainford EMC	N/A	N/A	21 Dec 2016	12
M1886	Test Receiver	Rohde & Schwarz	ESU26	100554	21 May 2016	12
A1534	Pre Amplifier	Hewlett Packard	8449B	3008A00405	19 Dec 2016	12
A1818	Antenna	EMCO	3115	00075692	17 Dec 2016	12
A253	Antenna	Flann Microwave	12240-20	128	17 Dec 2016	12
A254	Antenna	Flann Microwave	14240-20	139	17 Dec 2016	12
A255	Antenna	Flann Microwave	16240-20	519	17 Dec 2016	12
A256	Antenna	Flann Microwave	18240-20	400	17 Dec 2016	12
A436	Antenna	Flann Microwave	20240-20	330	19 Dec 2016	12
A1396	Attenuator	Huber & Suhner	6810.17.B	757987	05 May 2016	12
A1975	High Pass Filter	AtlanTecRF	AFH-03000	090424010	17 Apr 2016	12

5.2.6. Transmitter Band Edge Radiated Emissions**Test Summary:**

Test Engineer:	David Doyle	Test Date:	16 February 2016
Test Sample Serial Number:	02001-0354		

FCC Reference:	Parts 15.247(d) & 15.209(a)
Test Method Used:	ANSI C63.10 Section 6.10.4, 6.10.5 & KDB 558074 Section 11

Environmental Conditions:

Temperature (°C):	23
Relative Humidity (%):	31

Note(s):

1. The final measured value, for the given emission, in the table below incorporates the calibrated antenna factor and cable loss.
2. The maximum peak conducted output power was previously measured. In accordance with FCC KDB 558074 Section 11.1(a), the lower band edge measurement was performed with a peak detector and the -20 dBc limit applied.
3. There is a restricted band 10 MHz below the lower band edge. The test receiver was set up as follows: the RBW set to 1 MHz, the VBW set to 3 MHz, with the sweep time set to auto couple. Peak and average measurements were performed with their respective detectors. Markers were placed on the highest point on each trace.
4. * -20 dBc limit.

Transmitter Band Edge Radiated Emissions (continued)**Results: Peak**

Frequency (MHz)	Level (dB μ V/m)	Limit (dB μ V/m)	Margin (dB)	Result
2317.051	51.2	74.0	22.8	Complied
2400.000	43.1	82.1*	39.0	Complied
2483.500	51.8	74.0	22.2	Complied
2496.962	54.0	74.0	20.0	Complied

Results: Average

Frequency (MHz)	Level (dB μ V/m)	Limit (dB μ V/m)	Margin (dB)	Result
2332.179	42.5	54.0	11.5	Complied
2483.500	45.2	54.0	8.8	Complied
2484.702	45.9	54.0	8.1	Complied

Transmitter Band Edge Radiated Emissions (continued)

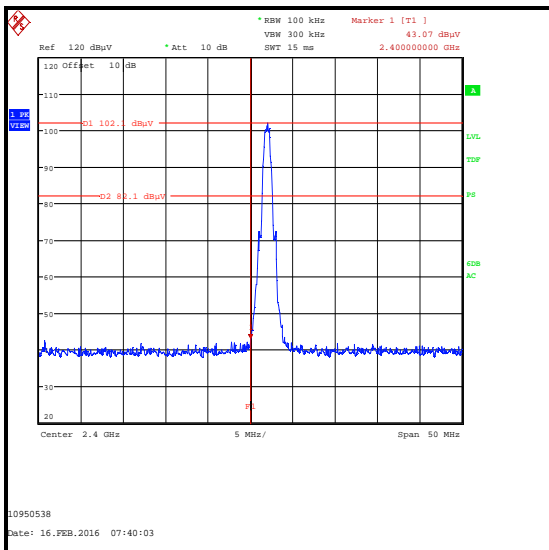

Lower Band Edge Peak Measurement

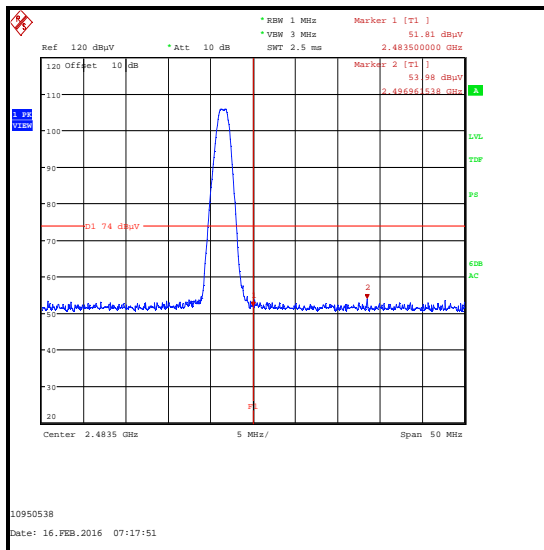

Upper Band Edge Peak Measurement

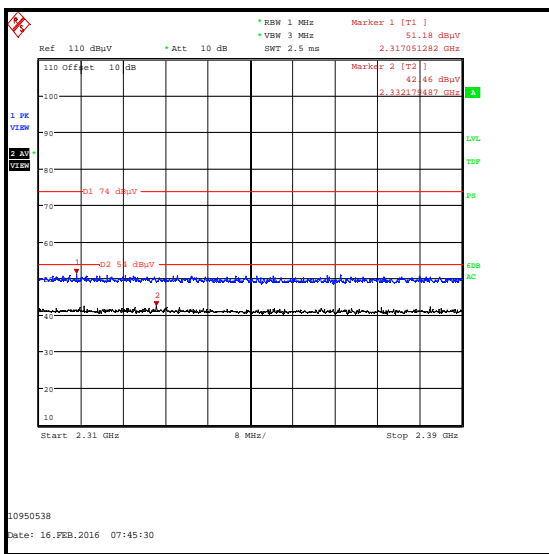

2310 MHz to 2390 MHz Restricted Band

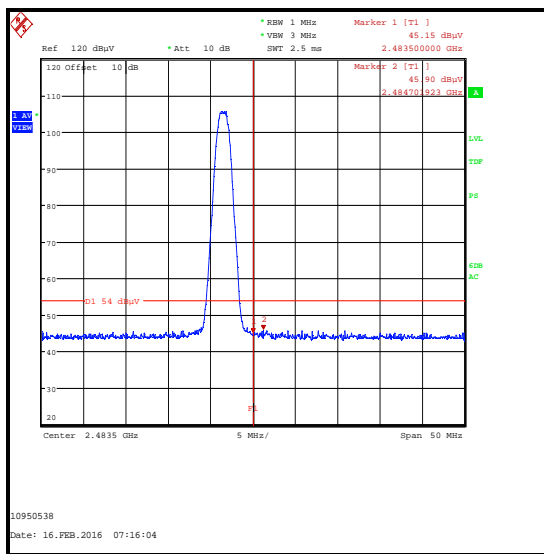

Upper Band Edge Average Measurement

Test Equipment Used:

Asset No.	Instrument	Manufacturer	Type No.	Serial No.	Date Calibration Due	Cal. Interval (Months)
M1656	Thermohygrometer	JM Handelpunkt	30.5015.13	None stated	23 Apr 2016	12
K0002	3m RSE Chamber	Rainford EMC	N/A	N/A	12 Jan 2017	12
M1886	Test Receiver	Rohde & Schwarz	ESU26	100554	21 May 2016	12
A1534	Pre Amplifier	Hewlett Packard	8449B	3008A00405	19 Dec 2016	12
A1818	Antenna	EMCO	3115	00075692	17 Dec 2016	12
A1396	Attenuator	Huber & Suhner	6810.17.B	757987	05 May 2016	12

6. Measurement Uncertainty

No measurement or test can ever be perfect and the imperfections give rise to error of measurement in the results. Consequently the result of a measurement is only an approximation to the value measured (the specific quantity subject to measurement) and is only complete when accompanied by a statement of the uncertainty of the approximation.

The expression of uncertainty of a measurement result allows realistic comparison of results with reference values and limits given in specifications and standards.

The uncertainty of the result may need to be taken into account when interpreting the measurement results.

The reported expanded uncertainties below are based on a standard uncertainty multiplied by an appropriate coverage factor such that a confidence level of approximately 95% is maintained. For the purposes of this document "approximately" is interpreted as meaning "effectively" or "for most practical purposes".

Measurement Type	Range	Confidence Level (%)	Calculated Uncertainty
AC Conducted Spurious Emissions	0.15 MHz to 30 MHz	95%	±4.69 dB
Conducted Maximum Peak Output Power	2.4 GHz to 2.4835 GHz	95%	±1.13 dB
Spectral Power Density	2.4 GHz to 2.4835 GHz	95%	±1.13 dB
Minimum 6 dB Bandwidth	2.4 GHz to 2.4835 GHz	95%	± 4.59%
Radiated Spurious Emissions	30 MHz to 1 GHz	95%	±5.65 dB
Radiated Spurious Emissions	1 GHz to 25 GHz	95%	±2.94 dB

The methods used to calculate the above uncertainties are in line with those recommended within the various measurement specifications. Where measurement specifications do not include guidelines for the evaluation of measurement uncertainty the published guidance of the appropriate accreditation body is followed.

7. Report Revision History

Version Number	Revision Details		
	Page No(s)	Clause	Details
1.0	-	-	Initial Version
2.0	33	-	Corrected calibration due date for Asset No. A1534

--- END OF REPORT ---