



# FCC REPORT

**Report Reference No.**..... : **TRE1509010405** R/C.....: 44681  
**FCC ID**..... : **2AF54-COMPLEX11T**  
**Applicant's name**..... : **FY International LLC.**  
 Address..... : 548 Donald St. Ste. 3, Bedford, NH 03110 USA  
 Manufacturer..... : Shenzhen AlldoCube Technology & Science Co., Ltd  
 Address..... : Building No.1,Sunwang Industrial Park, Xiahenglang Dalang,  
 Longhua District,Shenzhen, China  
**Test item description** ..... : **2 In 1 Tablet PC**  
 Trade Mark ..... : Cytrix  
 Model/Type reference..... : Complex 11t  
 Listed Model(s) ..... : i8  
**Standard** ..... : **47 CFR FCC Part 15 Subpart B - Unintentional Radiators**  
**ANSI C63.4: 2009**  
 Date of receipt of test sample..... : Sept 28, 2015  
 Date of testing..... : Sept 29, 2015-Oct 22, 2015  
 Date of issue..... : Oct 22, 2015  
**Result**..... : **Pass**

Compiled by  
 ( position+printed name+signature)..: File administrators Shayne Zhu

Supervised by  
 ( position+printed name+signature)..: Project Engineer Cary Luo

Approved by  
 ( position+printed name+signature)..: RF Manager Hans Hu

**Testing Laboratory Name** ..... : **Shenzhen Huatongwei International Inspection Co., Ltd**  
 Address..... : Bldg3, Hongfa Hi-tech Industrial Park, Genyu Road, Shenzhen,  
 China

**Shenzhen Huatongwei International Inspection Co., Ltd. All rights reserved.**

This publication may be reproduced in whole or in part for non-commercial purposes as long as the Shenzhen Huatongwei International Inspection Co., Ltd is acknowledged as copyright owner and source of the material. Shenzhen Huatongwei International Inspection Co., Ltd takes no responsibility for and will not assume liability for damages resulting from the reader's interpretation of the reproduced material due to its placement and context.

*The test report merely corresponds to the test sample.  
 It is not permitted to copy extracts of these test result without the written permission of the test laboratory.*

## Contents

<b>1.</b>	<b><u>TEST STANDARDS AND TEST DESCRIPTION .....</u></b>	<b><u>3</u></b>
1.1.	Test Standards	3
<b>2.</b>	<b><u>SUMMARY .....</u></b>	<b><u>4</u></b>
2.1.	Client Information	4
2.2.	Product Description	4
2.3.	EUT operation mode	4
2.4.	EUT configuration	4
<b>3.</b>	<b><u>TEST ENVIRONMENT .....</u></b>	<b><u>5</u></b>
3.1.	Address of the test laboratory	5
3.2.	Test Facility	5
3.3.	Environmental conditions	6
3.4.	Statement of the measurement uncertainty	6
3.5.	Equipments Used during the Test	6
<b>4.</b>	<b><u>TEST CONDITIONS AND RESULTS .....</u></b>	<b><u>7</u></b>
4.1.	Conducted Emissions Test	7
4.2.	Radiated Emission Test	10
<b>5.</b>	<b><u>TEST SETUP PHOTOS OF THE EUT .....</u></b>	<b><u>14</u></b>
<b>6.</b>	<b><u>EXTERNAL AND INTERNAL PHOTOS OF THE EUT .....</u></b>	<b><u>15</u></b>

## **1. TEST STANDARDS AND TEST DESCRIPTION**

### **1.1. Test Standards**

The tests were performed according to following standards:

[47 CFR FCC Part 15 Subpart B](#) - Unintentional Radiators

[ANSI C63.4: 2009](#) – American National Standard for Methods of Measurement of Radio-Noise Emissions from Low-Voltage Electrical and Electronic Equipment in the Range of 9 kHz to 40GHz

## 2. SUMMARY

### 2.1. Client Information

Applicant:	FY International LLC.
Address:	548 Donald St. Ste. 3, Bedford, NH 03110 USA
Manufacturer:	Shenzhen AlldoCube Technology & Science Co., Ltd
Address:	Building No.1, Sunwang Industrial Park, Xiahenglang Dalang, Longhua District, Shenzhen, China

### 2.2. Product Description

Name of EUT	2 In 1 Tablet PC
Trade Mark:	Cytrix
Model No.:	Complex 11t
Listed Model(s):	i8
Power supply:	DC 7.4V From internal battery
Adapter information:	Model name:FJ-SW1202000N Input:100-240Va.c.~50/60Hz,0.6Amax Output:12Vd.c., 2000mA

### 2.3. EUT operation mode

Test mode	USB Playing	SD Card Playing	Camera	USB Downloading
1	■			
2		■		
3			■	
4				■

Note:

1. ■ is operation mode.
2. Pre-scan above all test mode, found mode 4 which it was worse case mode.

### 2.4. EUT configuration

The following peripheral devices and interface cables were connected during the measurement:

● - supplied by the manufacturer

○ - supplied by the lab

○ Power Cable	Length (m) :	/
	Shield :	/
	Detachable :	/
○ Multimeter	Manufacturer :	/
	Model No. :	/

### **3. TEST ENVIRONMENT**

#### **3.1. Address of the test laboratory**

Laboratory: Shenzhen Huatongwei International Inspection Co., Ltd. (Gongming)  
Address: Bldg3, Hongfa Hi-tech Industrial Park, Genyu Road, Shenzhen, China  
Phone: 86-755-26748019 Fax: 86-755-26748089

#### **3.2. Test Facility**

The test facility is recognized, certified, or accredited by the following organizations:

##### **CNAS-Lab Code: L1225**

Shenzhen Huatongwei International Inspection Co., Ltd. has been assessed and proved to be in compliance with CNAS-CL01 Accreditation Criteria for Testing and Calibration Laboratories (identical to ISO/IEC 17025: 2005 General Requirements) for the Competence of Testing and Calibration Laboratories, Date of Registration: February 28, 2015. Valid time is until February 27, 2018.

##### **A2LA-Lab Cert. No. 2243.01**

Shenzhen Huatongwei International Inspection Co., Ltd. EMC Laboratory has been accredited by A2LA for technical competence in the field of electrical testing, and proved to be in compliance with ISO/IEC 17025: 2005 General Requirements for the Competence of Testing and Calibration Laboratories and any additional program requirements in the identified field of testing. Valid time is until Sept 30, 2015.

##### **FCC-Registration No.: 662850**

Shenzhen Huatongwei International Inspection Co., Ltd. EMC Laboratory has been registered and fully described in a report filed with the FCC (Federal Communications Commission). The acceptance letter from the FCC is maintained in our files. Registration 662850, Renewal date Jul. 01, 2012, valid time is until Jun. 01, 2015.

##### **FCC-Registration No.: 317478**

Shenzhen Huatongwei International Inspection Co., Ltd. (Gongming EMC Laboratory) has been registered and fully described in a report filed with the FCC (Federal Communications Commission). The acceptance letter from the FCC is maintained in our files. Registration 317478, Renewal date July 18, 2014, valid time is until July. 18, 2017.

##### **IC-Registration No.: 5377A**

The 3m Alternate Test Site of Shenzhen Huatongwei International Inspection Co., Ltd. has been registered by Certification and Engineering Bureau of Industry Canada for the performance of radiated measurements with Registration No. 5377A on Dec. 31, 2013, valid time is until Dec. 31, 2016.

##### **IC-Registration No.: 5377B**

The 3m Alternate Test Site of Shenzhen Huatongwei International Inspection Co., Ltd. (Gongming EMC Laboratory) has been registered by Certification and Engineering Bureau of Industry Canada for the performance of radiated measurements with Registration No. 5377B on September 3, 2014, valid time is until September 3, 2017.

##### **ACA**

Shenzhen Huatongwei International Inspection Co., Ltd. EMC Laboratory can also perform testing for the Australian C-Tick mark as a result of our A2LA accreditation.

##### **VCCI**

The 3m Semi-anechoic chamber (12.2m×7.95m×6.7m) of Shenzhen Huatongwei International Inspection Co., Ltd. has been registered in accordance with the Regulations for Voluntary Control Measures with Registration No.:R-2484. Date of Registration: Dec. 20, 2012. Valid time is until Dec. 29, 2015.

Radiated disturbance above 1GHz measurement of Shenzhen Huatongwei International Inspection Co., Ltd. has been registered in accordance with the Regulations for Voluntary Control Measures with Registration No.: G-292. Date of Registration: Dec. 24, 2013. Valid time is until Dec. 23, 2016.

Main Ports Conducted Interference Measurement of Shenzhen Huatongwei International Inspection Co., Ltd. has been registered in accordance with the Regulations for Voluntary Control Measures with Registration No.: C-2726. Date of Registration: Dec. 20, 2012. Valid time is until Dec. 19, 2015.

Telecommunication Ports Conducted Interference Measurement of Shenzhen Huatongwei International Inspection Co., Ltd. has been registered in accordance with the Regulations for Voluntary Control Measures with Registration No.: T-1837. Date of Registration: May 07, 2013. Valid time is until May 06, 2016.

##### **DNV**

Shenzhen Huatongwei International Inspection Co., Ltd. has been found to comply with the requirements of DNV towards subcontractor of EMC and safety testing services in conjunction with the EMC and Low voltage Directives and in the voluntary field. The acceptance is based on a formal quality Audit and follow-ups

according to relevant parts of ISO/IEC Guide 17025 (2005), in accordance with the requirements of the DNV Laboratory Quality Manual towards subcontractors. Valid time is until Aug. 24, 2016.

### 3.3. Environmental conditions

During the measurement the environmental conditions were within the listed ranges:

Temperature: 15-35 ° C

Humidity: 30-60 %

Atmospheric pressure: 950-1050mbar

### 3.4. Statement of the measurement uncertainty

The data and results referenced in this document are true and accurate. The reader is cautioned that there may be errors within the calibration limits of the equipment and facilities. The measurement uncertainty was calculated for all measurements listed in this test report acc. to CISPR 16 - 4 „Specification for radio disturbance and immunity measuring apparatus and methods – Part 4: Uncertainty in EMC Measurements“ and is documented in the Shenzhen Huatongwei International Inspection Co., Ltd quality system acc. to DIN EN ISO/IEC 17025. Furthermore, component and process variability of devices similar to that tested may result in additional deviation. The manufacturer has the sole responsibility of continued compliance of the device.

Hereafter the best measurement capability for Shenzhen Huatongwei laboratory is reported:

Test	Range	Measurement Uncertainty	Notes
Radiated Emission	30~1000MHz	4.24 dB	(1)
Radiated Emission	1~18GHz	5.16 dB	(1)
Radiated Emission	18-40GHz	5.54 dB	(1)
Conducted Disturbance	0.15~30MHz	3.39 dB	(1)

- (1) This uncertainty represents an expanded uncertainty expressed at approximately the 95% confidence level using a coverage factor of k=2.

### 3.5. Equipments Used during the Test

Conducted Emission					
Item	Test Equipment	Manufacturer	Model No.	Serial No.	Last Cal.
1	EMI TEST RECEIVER	Rohde & Schwarz	ESCI	100106	2014/11/1
2	ARTIFICIAL MAINS	Rohde & Schwarz	ESH2-Z5	100028	2014/11/1
3	PULSE LIMITER	Rohde & Schwarz	ESHSZ2	100044	2014/11/1
4	EMI TEST SOFTWARE	Rohde & Schwarz	ES-K1	N/A	N/A

Radiated Emission					
Item	Test Equipment	Manufacturer	Model No.	Serial No.	Last Cal.
1	ULTRA-BROADBAND ANTENNA	ShwarzBeck	VULB9163	538	2014/11/1
2	EMI TEST RECEIVER	Rohde & Schwarz	ESI 26	100009	2014/11/1
3	EMI TEST Software	Audix	E3	N/A	N/A
4	TURNTABLE	MATURO	TT2.0	----	N/A
5	ANTENNA MAST	MATURO	TAM-4.0-P	----	N/A
6	EMI TEST Software	Rohde & Schwarz	ESK1	N/A	N/A
7	ULTRA-BROADBAND ANTENNA	Rohde&Schwarz	HL562	100015	2014/11/1
8	Amplifier	Sonoma	310N	E009-13	2014/11/1
9	JS amplifier	Rohde & Schwarz	JS4-00101800-28-5A	F201504	2014/11/1
11	TURNTABLE	ETS	2088	2149	N/A
12	ANTENNA MAST	ETS	2075	2346	N/A
13	HORN ANTENNA	Rohde&Schwarz	HF906	100039	2014/11/1

The calibration interval was one year.

## 4. TEST CONDITIONS AND RESULTS

### 4.1. Conducted Emissions Test

#### TEST CONFIGURATION

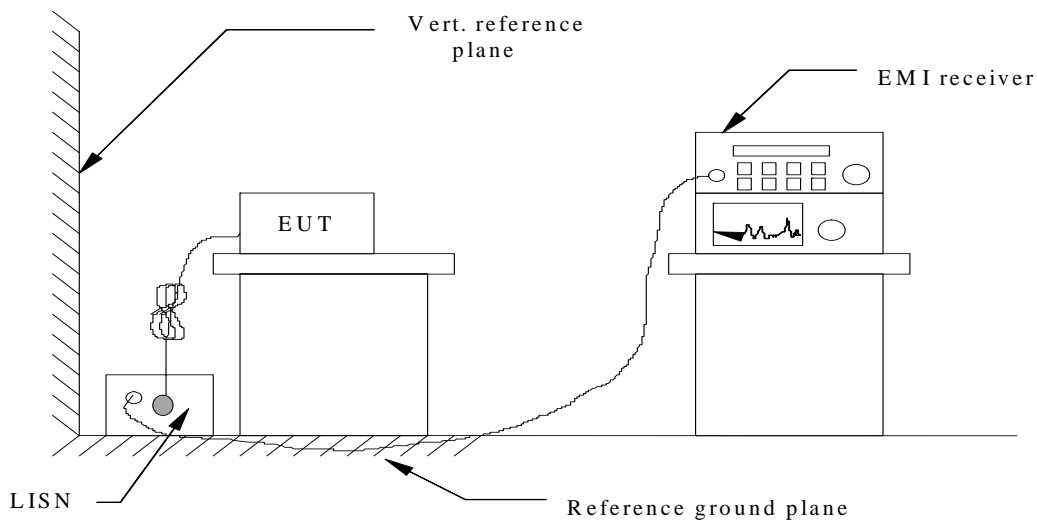

#### TEST PROCEDURE

1. The equipment was set up as per the test configuration to simulate typical actual usage per the user's manual. The EUT is a tabletop system; a wooden table with a height of 0.8 meters is used and is placed on the ground plane as per ANSI C63.4-2009.
2. Support equipment, if needed, was placed as per ANSI C63.4-2009.
3. All I/O cables were positioned to simulate typical actual usage as per ANSI C63.4-2009.
4. The EUT received DC 5.0 from USB powered from AC120V/60Hz power through a Line Impedance Stabilization Network (LISN) which supplied power source and was grounded to the ground plane.
5. All support equipments received AC power from a second LISN, if any.
6. The EUT test program was started. Emissions were measured on each current carrying line of the EUT using a spectrum Analyzer / Receiver connected to the LISN powering the EUT. The LISN has two monitoring points: Line 1 (Hot Side) and Line 2 (Neutral Side). Two scans were taken: one with Line 1 connected to Analyzer / Receiver and Line 2 connected to a 50 ohm load; the second scan had Line 1 connected to a 50 ohm load and Line 2 connected to the Analyzer / Receiver.
7. Analyzer / Receiver scanned from 150 KHz to 30MHz for emissions in each of the test modes.
8. During the above scans, the emissions were maximized by cable manipulation.

#### CONDUCTED POWER LINE EMISSION LIMIT

For unintentional device, according to § 15.107(a) Line Conducted Emission Limits is as following :

Frequency (MHz)	Maximum RF Line Voltage (dBµV)			
	CLASS A		CLASS B	
	Q.P.	Ave.	Q.P.	Ave.
0.15 - 0.50	79	66	66-56*	56-46*
0.50 - 5.00	73	60	56	46
5.00 - 30.0	73	60	60	50

\* Decreasing linearly with the logarithm of the frequency

#### TEST RESULTS

Passed       Not Applicable

mode 4:  
N:

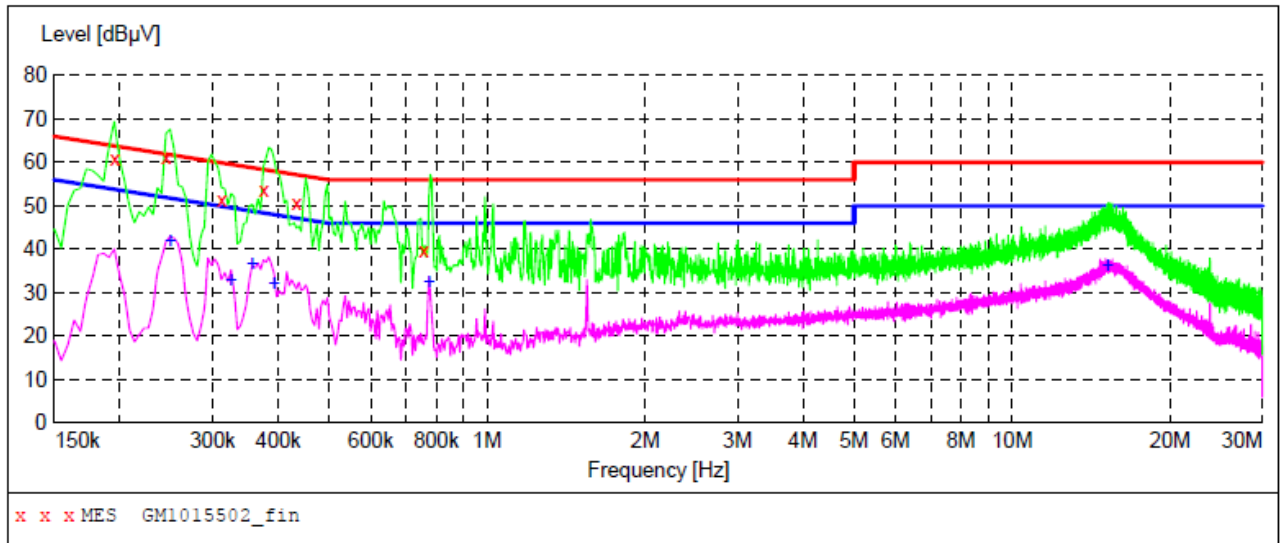

Frequency MHz	Level dBµV	Transd dB	Limit dBµV	Margin dB	Detector	Line	PE
0.195000	61.00	10.2	64	2.8	QP	N	GND
0.244500	59.40	10.2	62	2.6	QP	N	GND
0.312000	51.30	10.2	60	8.6	QP	N	GND
0.375000	53.50	10.2	58	4.9	QP	N	GND
0.433500	50.50	10.2	57	6.7	QP	N	GND
0.757500	39.70	10.2	56	16.3	QP	N	GND
Frequency MHz	Level dBµV	Transd dB	Limit dBµV	Margin dB	Detector	Line	PE
0.249000	41.90	10.2	52	9.9	AV	N	GND
0.325500	32.90	10.2	50	16.7	AV	N	GND
0.357000	36.80	10.2	49	12.0	AV	N	GND
0.393000	32.20	10.2	48	15.8	AV	N	GND
0.775500	32.40	10.2	46	13.6	AV	N	GND
15.198000	36.30	10.8	50	13.7	AV	N	GND



L1:

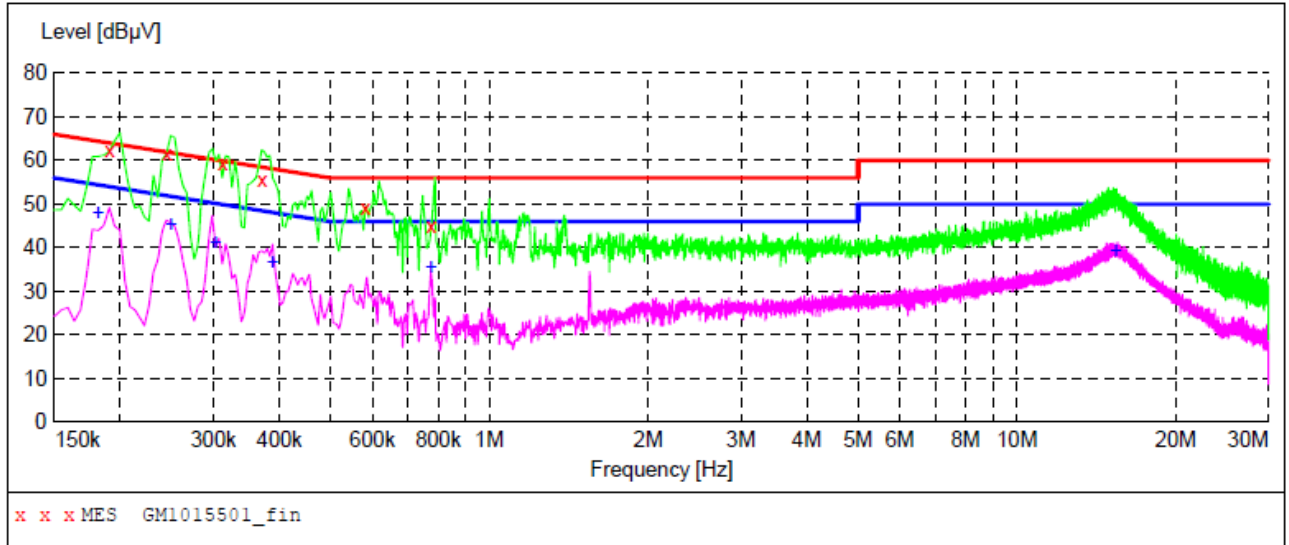

Frequency MHz	Level dBµV	Transd dB	Limit dBµV	Margin dB	Detector	Line	PE
0.190500	62.20	10.2	64	1.8	QP	L1	GND
0.244500	59.60	10.2	62	2.4	QP	L1	GND
0.312000	57.40	10.2	60	2.6	QP	L1	GND
0.370500	55.40	10.2	59	3.1	QP	L1	GND
0.582000	49.20	10.2	56	6.8	QP	L1	GND
0.775500	45.10	10.2	56	10.9	QP	L1	GND
Frequency MHz	Level dBµV	Transd dB	Limit dBµV	Margin dB	Detector	Line	PE
0.181500	48.00	10.2	54	6.4	AV	L1	GND
0.249000	45.30	10.2	52	6.5	AV	L1	GND
0.303000	41.10	10.2	50	9.1	AV	L1	GND
0.388500	36.60	10.2	48	11.5	AV	L1	GND
0.775500	35.60	10.2	46	10.4	AV	L1	GND
15.400500	39.30	10.8	50	10.7	AV	L1	GND

## 4.2. Radiated Emission Test

### TEST CONFIGURATION

#### a) Radiated Emission Test Set-Up, Frequency below 1000MHz

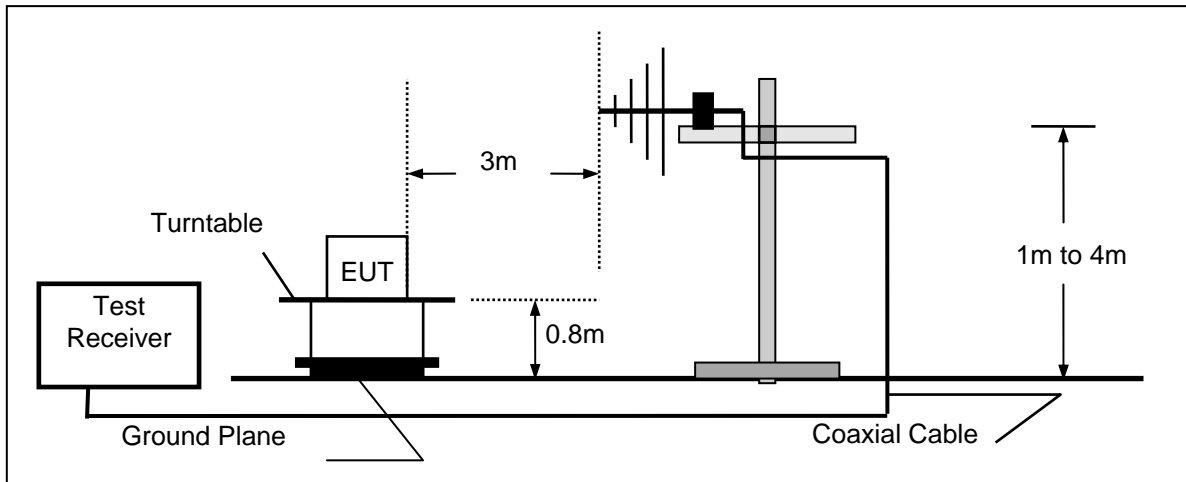

#### b) Radiated Emission Test Set-Up, Frequency above 1000MHz

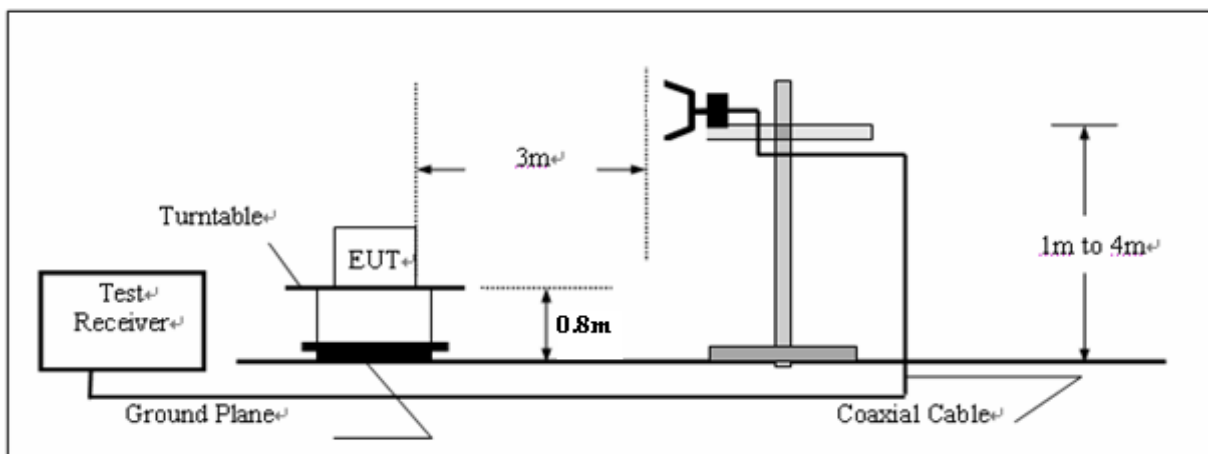

### TEST PROCEDURE

1. The EUT is placed on a turntable, which is 0.8m above ground plane.
2. The turntable shall be rotated for 360 degrees to determine the position of maximum emission level.
3. EUT is set 3m away from the receiving antenna, which is varied from 1m to 4m to find out the highest emissions.
4. Maximum procedure was performed on the six highest emissions to ensure EUT compliance.
5. And also, each emission was to be maximized by changing the polarization of receiving antenna both horizontal and vertical.
6. Repeat above procedures until the measurements for all frequencies are complete.
7. The maximum operation frequency was 512MHz, the radiated emission test frequency from 30MHz to 18GHz.

**FIELD STRENGTH CALCULATION**

The field strength is calculated by adding the Antenna Factor and Cable Factor and subtracting the Amplifier Gain and Duty Cycle Correction Factor (if any) from the measured reading. The basic equation with a sample calculation is as follows:

$$FS = RA + AF + CL - AG$$

Where FS = Field Strength	CL = Cable Attenuation Factor (Cable Loss)
RA = Reading Amplitude	AG = Amplifier Gain
AF = Antenna Factor	

For example

Frequency (MHz)	FS (dB $\mu$ V/m)	RA (dB $\mu$ V/m)	AF (dB)	CL (dB)	AG (dB)	Transd (dB)
300.00	40	58.1	12.2	1.6	31.90	-18.1

$$\text{Transd} = \text{AF} + \text{CL} - \text{AG}$$

**RADIATION LIMIT**

For unintentional device, according to § 15.109(a), except for Class A digital devices, the field strength of radiated emissions from unintentional radiators at a distance of 3 meters shall not exceed the following values:

Frequency (MHz)	Distance (Meters)	Radiated (dB $\mu$ V/m)	Radiated ( $\mu$ V/m)
30-88	3	40.0	100
88-216	3	43.5	150
216-960	3	46.0	200
Above 960	3	54.0	500

**TEST RESULTS**

mode 4:

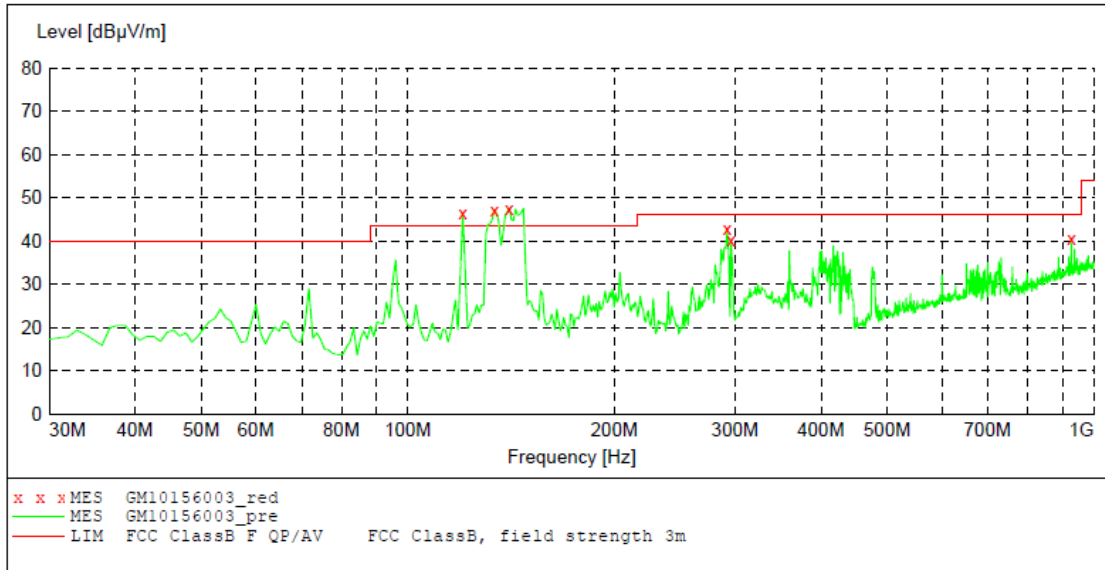

Frequency MHz	Level dBµV/m	Transd dB	Limit dBµV/m	Margin dB	Det.	Height cm	Azimuth deg	Polarization
120.210000	40.40	-15.9	43.5	3.1	QP	300.0	160.00	HORIZONTAL
133.790000	40.00	-17.6	43.5	3.5	QP	300.0	14.00	HORIZONTAL
140.580000	49.40	-18.2	43.5	4.1	QP	300.0	160.00	HORIZONTAL
291.900000	42.70	-14.0	46.0	3.3	QP	100.0	191.00	HORIZONTAL
295.780000	40.30	-13.9	46.0	5.7	QP	100.0	310.00	HORIZONTAL
927.250000	40.40	3.2	46.0	5.6	QP	100.0	310.00	HORIZONTAL

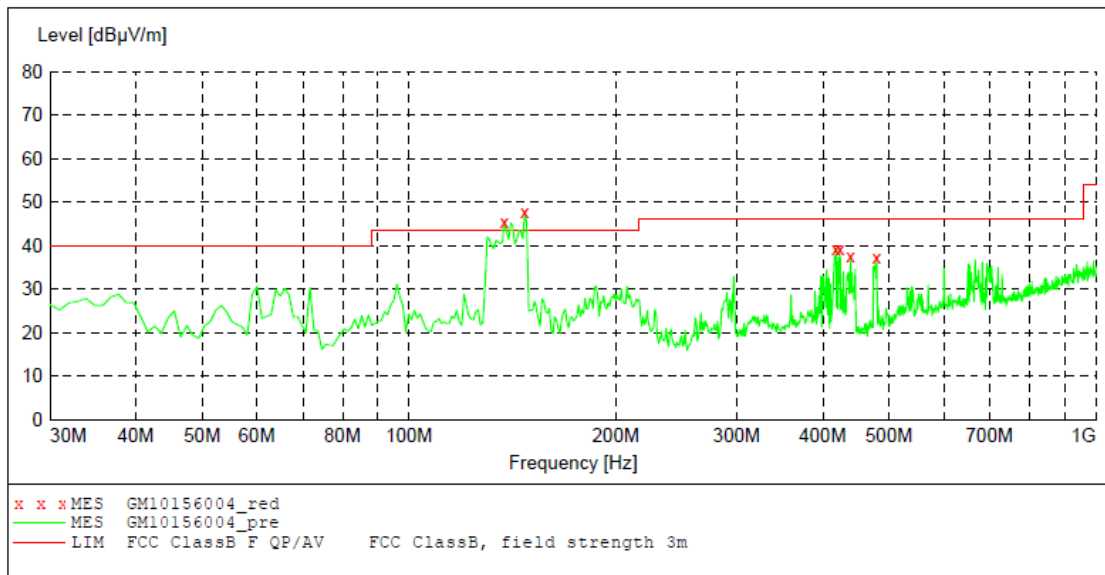

Frequency MHz	Level dBµV/m	Transd dB	Limit dBµV/m	Margin dB	Det.	Height cm	Azimuth deg	Polarization
137.670000	39.40	-18.0	43.5	4.1	QP	100.0	269.00	VERTICAL
147.370000	38.20	-18.0	43.5	5.3	QP	100.0	196.00	VERTICAL
418.000000	39.30	-10.1	46.0	6.7	QP	100.0	168.00	VERTICAL
423.820000	39.20	-9.9	46.0	6.8	QP	100.0	168.00	VERTICAL
439.340000	37.50	-9.3	46.0	8.5	QP	100.0	143.00	VERTICAL
479.110000	37.30	-8.0	46.0	8.7	QP	100.0	168.00	VERTICAL

Above 1GHz

HORIZONTAL

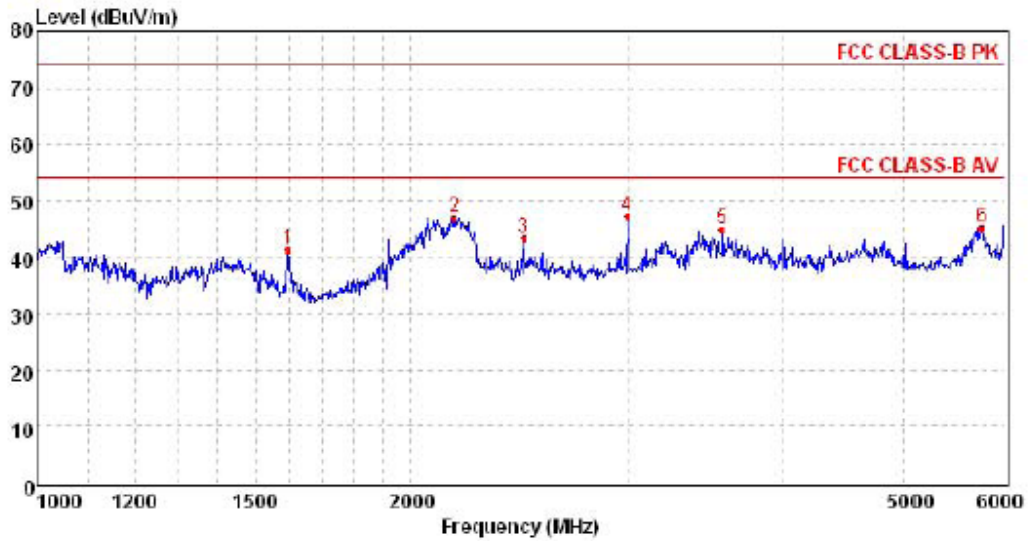

Mark	Frequency MHz	Reading dBuV/m	Antenna dB	Cable dB	Preamp dB	Level dBuV/m	Limit dBuV/m	Over limit	Remark
1	1593.38	47.92	24.99	5.39	36.92	41.38	74.00	-32.62	Peak
2	2168.51	51.21	26.75	6.45	37.40	47.01	74.00	-26.99	Peak
3	2467.11	46.38	27.78	6.93	37.63	43.46	74.00	-30.54	Peak
4	2988.48	48.69	28.49	8.15	37.98	47.35	74.00	-26.65	Peak
5	3562.13	45.20	28.82	8.77	37.99	44.80	74.00	-29.20	Peak
6	5747.46	40.71	32.80	9.69	38.08	45.12	74.00	-28.88	Peak

VERTICAL

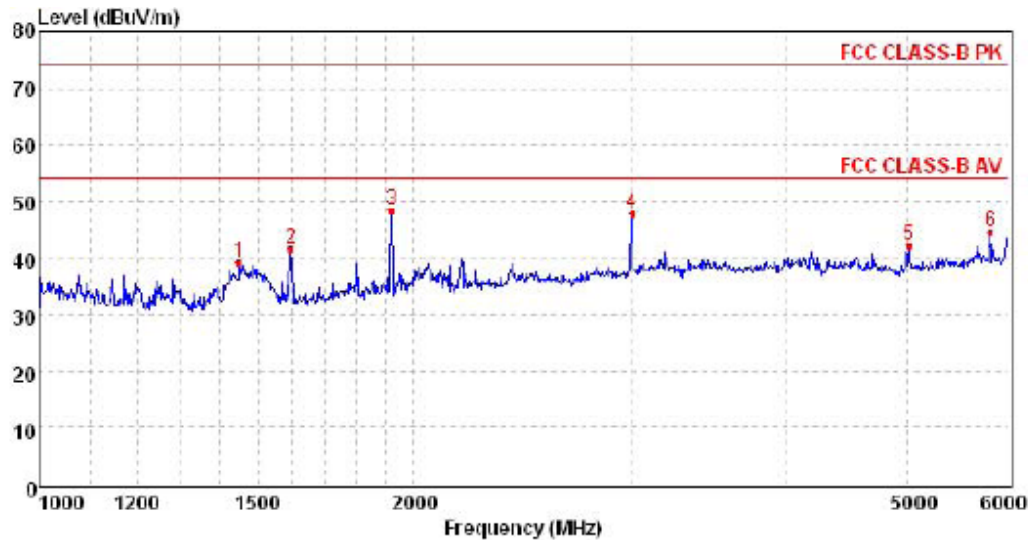

Mark	Frequency MHz	Reading dBuV/m	Antenna dB	Cable dB	Preamp dB	Level dBuV/m	Limit dBuV/m	Over limit	Remark
1	1449.03	46.28	24.66	5.08	36.78	39.24	74.00	-34.76	Peak
2	1593.38	48.18	24.99	5.39	36.92	41.64	74.00	-32.36	Peak
3	1919.76	53.72	25.90	6.02	37.19	48.45	74.00	-25.55	Peak
4	2999.21	49.07	28.50	8.17	37.99	47.75	74.00	-26.25	Peak
5	5006.77	40.33	31.20	9.34	38.65	42.22	74.00	-31.78	Peak
6	5799.18	40.16	32.88	9.71	38.04	44.71	74.00	-29.29	Peak

## 5. Test Setup Photos of the EUT

Conducted Emission (AC Mains)



Radiated Emission (30MHz-1GHz)

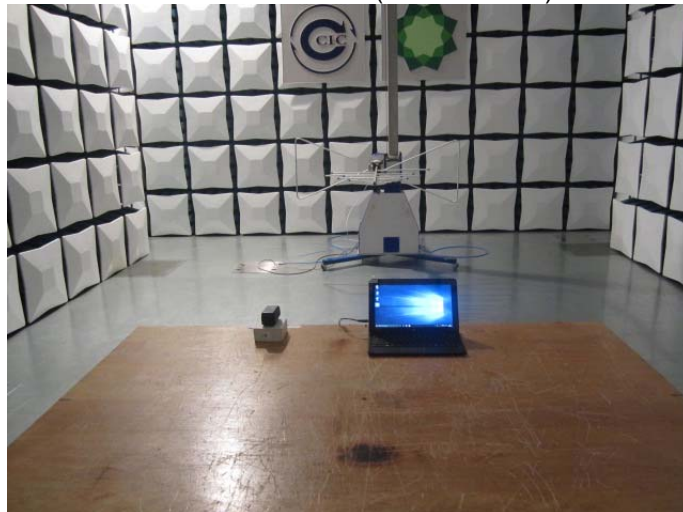

Radiated Emission (above 1GHz)



## **6. External and Internal Photos of the EUT**

Reference to Test Report TRE1509010401.

.....End of Report.....