

EMC TEST REPORT

No. 150601278SHA-002

Applicant : Yanzi Networks AB
Isafjordgatan 32C, 16440 Kista Sweden

Manufacturer : Shanghai Pinyuan Info. Co., Ltd.
1007 No.9, No.970 Dalian Road, Shanghai 200082,
China

Product Name : IoT Dongle

Type/Model : IOT-U10

TEST RESULT : PASS

SUMMARY

The equipment complies with the requirements according to the following standard(s) or specification:

47CFR Part 15 (2014): Radio Frequency Devices (Subpart B)

ICES-003 Issue 5 (2012): Information Technology Equipment (ITE) – Limits and methods of measurement

ANSI C63.4 (2014): American National Standard for Methods of Measurement of Radio-Noise Emissions from Low-Voltage Electrical and Electronic Equipment in the Range of 9 kHz to 40 GHz

Date of issue: July 20, 2015

Prepared by:



Nemo Li (*Project Engineer*)

Reviewed by:



Daniel Zhao (*Reviewer*)

Content

SUMMARY	1
1 GENERAL INFORMATION	3
1.1 Description of Equipment Under Test (EUT).....	3
1.2 Description of Client.....	4
1.3 Description of Test Facility	4
2 TEST SPECIFICATIONS	5
2.1 Standards or specification	5
2.2 Mode of operation during the test.....	5
2.3 Test software list	5
2.4 Test peripherals list	5
2.5 Instrument list	6
2.6 Test Summary	7
3 CONDUCTED EMISSION	8
3.1 Limits	8
3.1.1 Limits for conducted emission of class A device	8
3.1.2 Limits for conducted emission of class B device.....	8
3.2 Test setup	9
3.3 Test Setup and Test Procedure.....	10
3.4 Test Protocol	11
4 RADIATED EMISSION	13
4.1 Radiated emission limits	13
4.1.1 Limits for radiated emission of class A device.....	13
4.1.2 Limits for radiated emission of class B device	13
4.2 Block diagram and test set up	14
4.3 Test Setup and Test Procedure.....	15
4.4 Test Protocol	16
APPENDIX I: PHOTOGRAPH OF EQUIPMENT UNDER TEST	19

1 GENERAL INFORMATION

1.1 Description of Equipment Under Test (EUT)

Product Name : IoT Dongle
Type/Model : IOT-U10
Description of EUT : This EUT is an IoT-dongle which is designed for indoor use only.
Rating : USB 5Vdc
I/O Port : USB port
Category of EUT : Class B
EUT type : Table top
 Floor standing
Highest operating frequency : Less than 108MHz
Sample received date : 2015.6.18
Sample identification No. : --
Date of test : 2015.6.18 – 2015.7.5

1.2 Description of Client

Applicant : Yanzi Networks AB
Isafjordgatan 32C, 16440 Kista Sweden

Name of contact : Stefan Sandhagen
Tel : +46 8 559 21 440
Fax : --
Email : stefan@yanzi.se

Manufacturer : Shanghai Pinyuan Info. Co., Ltd.
1007 No.9, No.970 Dalian Road, Shanghai 200082,
China

1.3 Description of Test Facility

Name : Intertek Testing Service Shanghai
Address : Building 86, No. 1198 Qinzhou Road(North), Shanghai
200233, P.R. China
Telephone : 86 21 61278200
Telefax : 86 21 54262353

Subcontractor:

Name : Shanghai Institute of Measurement Technology
Address : 716 Yishan Road, Shanghai 200233, P.R. China
Telephone : 86 21 64700066
Telefax :

2 TEST SPECIFICATIONS

2.1 Standards or specification

47CFR Part 15 (2014): Radio Frequency Device: Subpart B

ICES-003 Issue 5 (2012): Information Technology Equipment (ITE) – Limits and methods of measurement

ANSI C63.4 (2014): Interim Standard for Methods of Measurement of Radio-Noise Emissions from Low-Voltage Electrical and Electronic Equipment in the Range of 9 kHz to 40GHz.

2.2 Mode of operation during the test

Within this test report, EUT was tested with modulation and tested under its rating voltage and frequency.

2.3 Test software list

Test Items	Software	Manufacturer	Version
Conducted emission	ESxS-K1	R&S	V2.1.0
Radiated emission	ES-K1	R&S	V1.71

2.4 Test peripherals list

Item No.	Name	Band and Model	Description
1	Laptop computer	HP ProBook 6470b	100-240V AC, 50/60Hz

2.5 Instrument list

Equipment	Type	Manu.	Internal no.	Cal. Date	Due date
Test Receiver	ESCS 30	R&S	EC 2107	2014-10-21	2015-10-20
Test Receiver	ESIB 26	R&S	EC 3045	2014-10-20	2015-10-19
Test Receiver	ESCI 7	R&S	EC4501	2014-12-29	2015-12-28
Spectrum Analyzer	N9010	Agilent	EC4890	2014-10-21	2015-10-20
Spectrum Analyzer	E4446	Agilent	/	2014-10-21	2015-10-20
Power meter	ML 2495A	Anritsu	EC 4895	2014-10-21	2015-10-20
A.M.N.	ESH2-Z5	R&S	EC 3119	2015-1-9	2016-1-8
Bilog Antenna	CBL 6112D	TESEQ	EC 4206	2015-5-15	2016-5-14
Horn antenna	HF 906	R&S	EC 3049	2015-5-12	2016-5-11
Pre-amplifier	Pre-amp 18	R&S	EC 3222	2015-4-11	2016-4-10
Pre-amplifier	Tpa0118-40	R&S	EC 4792-2	2015-4-11	2016-4-10
Log-period antenna	AT 1080	AR	EC 3044-7	2015-5-21	2016-5-20
Biconical antenna	3109PX	ETS	EC3564	2014-8-25	2015-8-24
Semi-anechoic chamber	-	Albatross project	EC 3048	2015-5-20	2016-5-19
Shielded room	-	Zhongyu	EC 2838	2015-1-12	2016-1-11
Shielded room	-	Zhongyu	EC 2839	2015-1-12	2016-1-11
High Pass Filter	WHKX 1.0/15G-10SS	Wainwright	EC4297-1	2015-2-1	2016-1-31
High Pass Filter	WHKX 2.8/18G-12SS	Wainwright	EC4297-2	2015-2-1	2016-1-31
High Pass Filter	WHKX 7.0/1.8G-8SS	Wainwright	EC4297-3	2015-2-1	2016-1-31
Band Reject Filter	WRCGV 2400/2483-2390/2493-35/10SS	Wainwright	EC4297-4	2015-2-1	2016-1-31
MXG Analog Signal Generator	N5181A	KEYSIGHT	EC5338-2	2014-11-7	2015-11-6
MXG Vector Signal Generator	N51812B	KEYSIGHT	EC5175	2014-12-30	2015-12-29
Power sensor	U2021XA	KEYSIGHT	EC5338-1	2014-10-2	2015-10-1
PXA Signal Analyzer	N9030A	KEYSIGHT	EC5338	2014-11-18	2015-11-17

2.6 Test Summary

This report applies to tested sample only. The test results have been compared directly with the limits, and the measurement uncertainty is recorded. This report shall not be reproduced in part without written approval of Intertek Testing Service Shanghai Limited.

TEST ITEM	FCC REFERANCE	RESULT
Conducted emission	15.107	Pass
Radiated emission	15.109	Pass

Notes: 1: NA =Not Applicable

3 Conducted emission

Test result: Pass

3.1 Limits

3.1.1 Limits for conducted emission of class A device

Frequency range (MHz)	Limits dB(μ V)	
	Quasi-peak	Average
0.15 ~ 0.5	79	66
0.5 ~ 30	73	60

Note: If the limit for the measurement with the average detector is met when using a receiver with a quasi-peak detector, the equipment under test shall be deemed to meet both limits and the measurement using the receiver with an average detector need not be carried out.

3.1.2 Limits for conducted emission of class B device

Frequency range (MHz)	Limits dB(μ V)	
	Quasi-peak	Average
0.15 ~ 0.5	66 ~ 56 *	56 ~ 46 *
0.5 ~ 5	56	46
5 ~ 30	60	50

Note: 1. * Means the limit decreasing linearly with the logarithm of the frequency in the range 0.15MHz to 0.5MHz
2. If the limit for the measurement with the average detector is met when using a receiver with a quasi-peak detector, the equipment under test shall be deemed to meet both limits and the measurement using the receiver with an average detector need not be carried out.

3.2 Test setup

For table top equipment

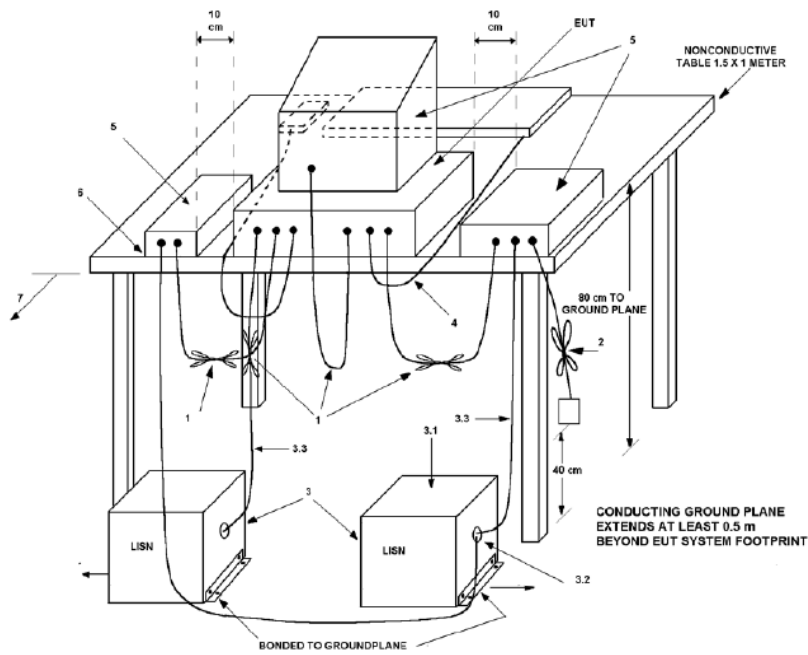

For floor standing equipment

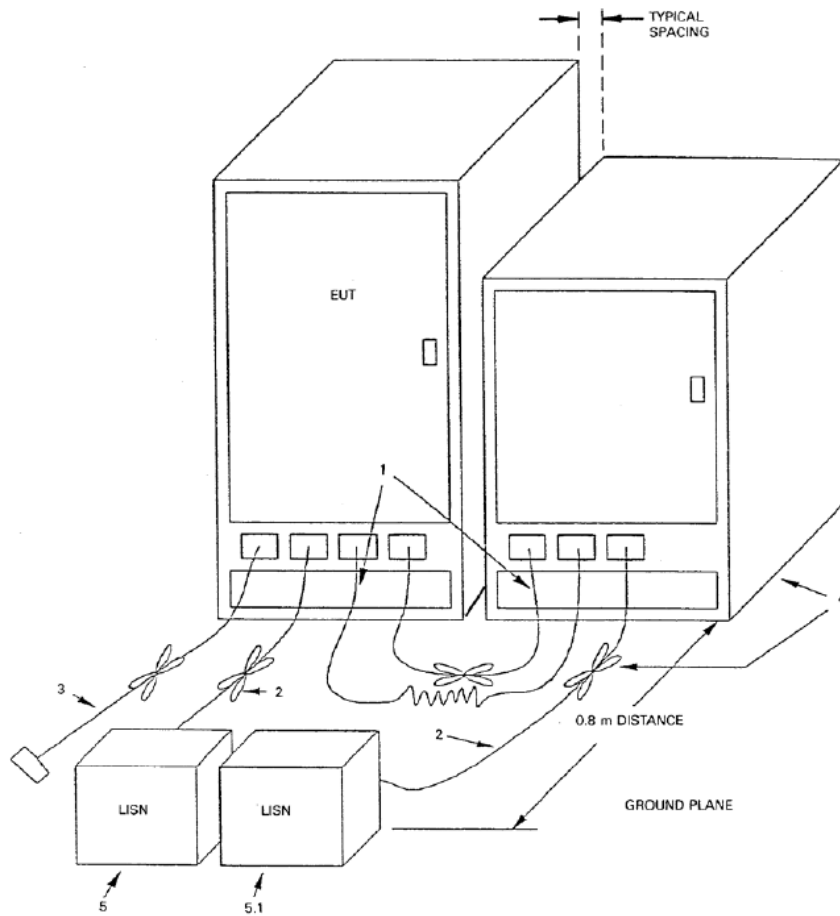

3.3 Test Setup and Test Procedure

Measurement was performed in shielded room, and instruments used were following clause 4 and clause 5 of ANSI 63.4.

Detailed test procedure was following clause 7.3 of ANSI 63.4.

EUT arrangement and operation conditions were according to clause 6 and clause 7 of ANSI 63.4.

Frequency range 150kHz – 30MHz was checked and EMI receiver measurement bandwidth was set to 9 kHz.

3.4 Test Protocol

Temperature: 24 °C
Relative Humidity: 52 %

L line:

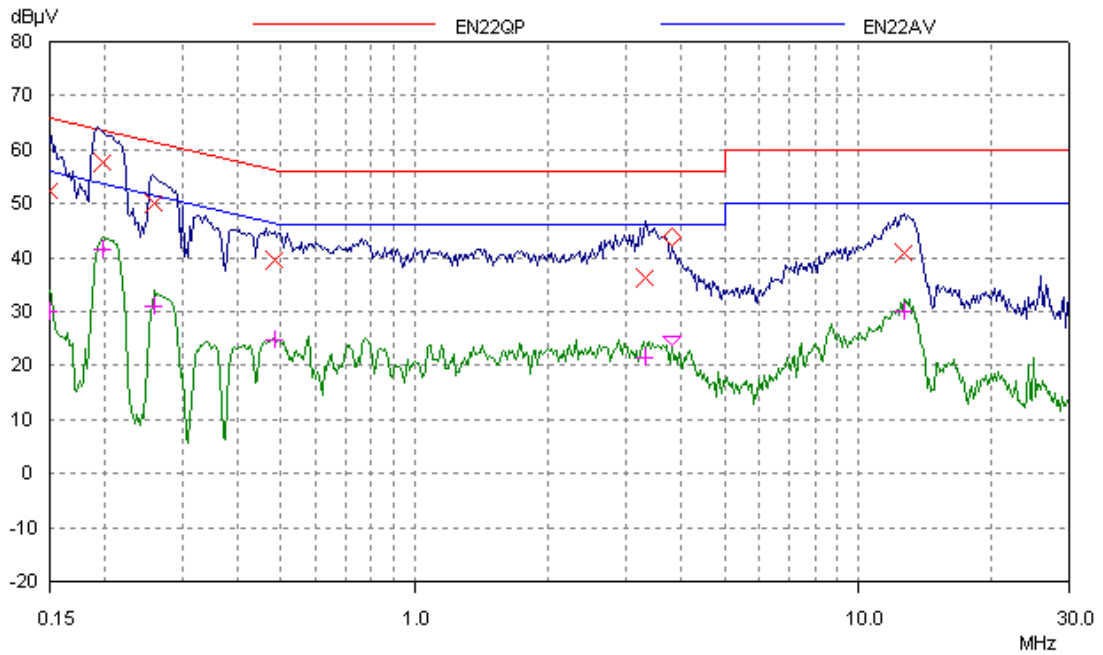

Test Data:

Frequency (MHz)	Quasi-peak			Average		
	level dB(µV)	Limit dB(µV)	Margin (dB)	level dB(µV)	limit dB(µV)	Margin (dB)
0.150	52.22	66.00	13.78	*	56.00	*
0.198	57.68	63.71	6.03	41.47	53.71	12.24
0.256	39.93	61.56	11.63	*	51.56	*
0.483	39.50	56.29	16.79	*	46.29	*
3.309	36.25	56.00	19.75	*	46.00	*
12.655	40.79	60.00	19.21	30.11	50.00	19.89

Remark: If the margin higher than 20dB, it would be marked as *.

N line:

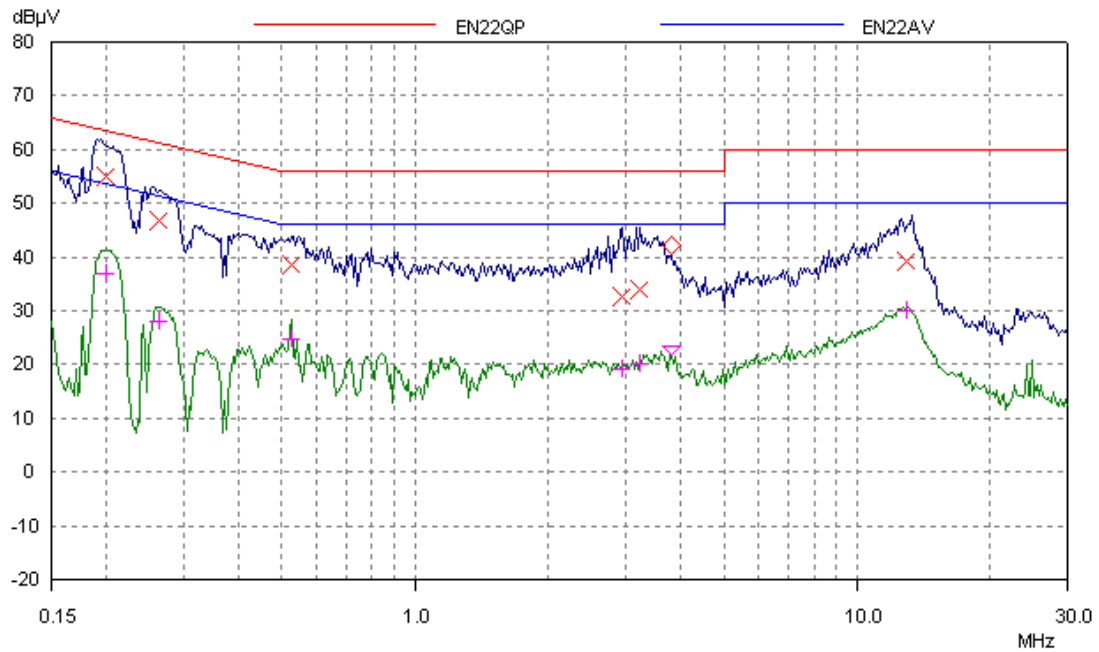

Test Data:

Frequency (MHz)	Quasi-peak			Average		
	level dB(µV)	Limit dB(µV)	Margin (dB)	level dB(µV)	limit dB(µV)	Margin (dB)
0.198	54.89	63.68	8.79	36.78	53.68	16.90
0.262	46.94	61.36	14.42	28.06	51.36	23.30
0.523	38.54	56.00	17.46	24.88	46.00	21.12
2.936	32.58	56.00	23.42	19.14	46.00	26.86
3.205	33.97	56.00	22.03	20.28	46.00	25.72
12.961	39.27	60.00	20.73	30.06	50.00	19.94

Remark: If the margin higher than 20dB, it would be marked as *.

Notes: All possible modes of operation were investigated. Only the worst case emissions was measured.

4 Radiated emission

Test result: Pass

4.1 Radiated emission limits

4.1.1 Limits for radiated emission of class A device

Frequency (MHz)	Permitted limit in dB μ V/m (Quasi-peak) of Measurement Distance 10m
30 – 88	39
88 – 216	43.5
216 – 960	46.4
Above 960	49.5
Note: for the measurement distance other than 3m and 10m, the limit is varied according to 20dB/10 decades.	

4.1.2 Limits for radiated emission of class B device

Frequency (MHz)	Permitted limit in dB μ V/m (Quasi-peak) of Measurement Distance 3m
30 – 88	40.0
88 – 216	43.5
216 – 960	46.0
Above 960	54.0
Note: for the measurement distance other than 3m and 10m, the limit is varied according to 20dB/10 decades.	

4.2 Block diagram and test set up

For table top equipment

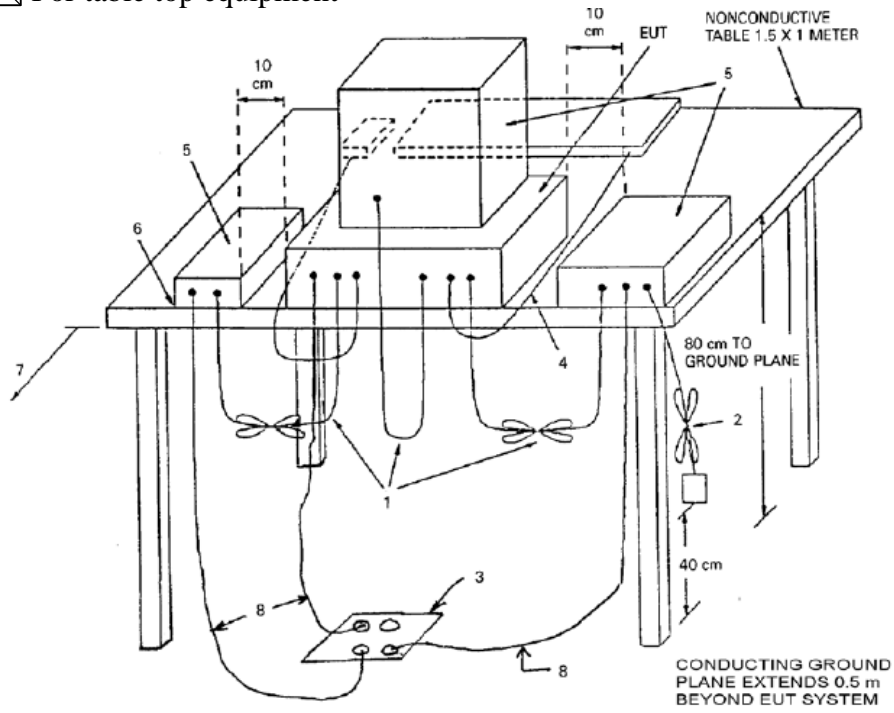

For floor standing equipment

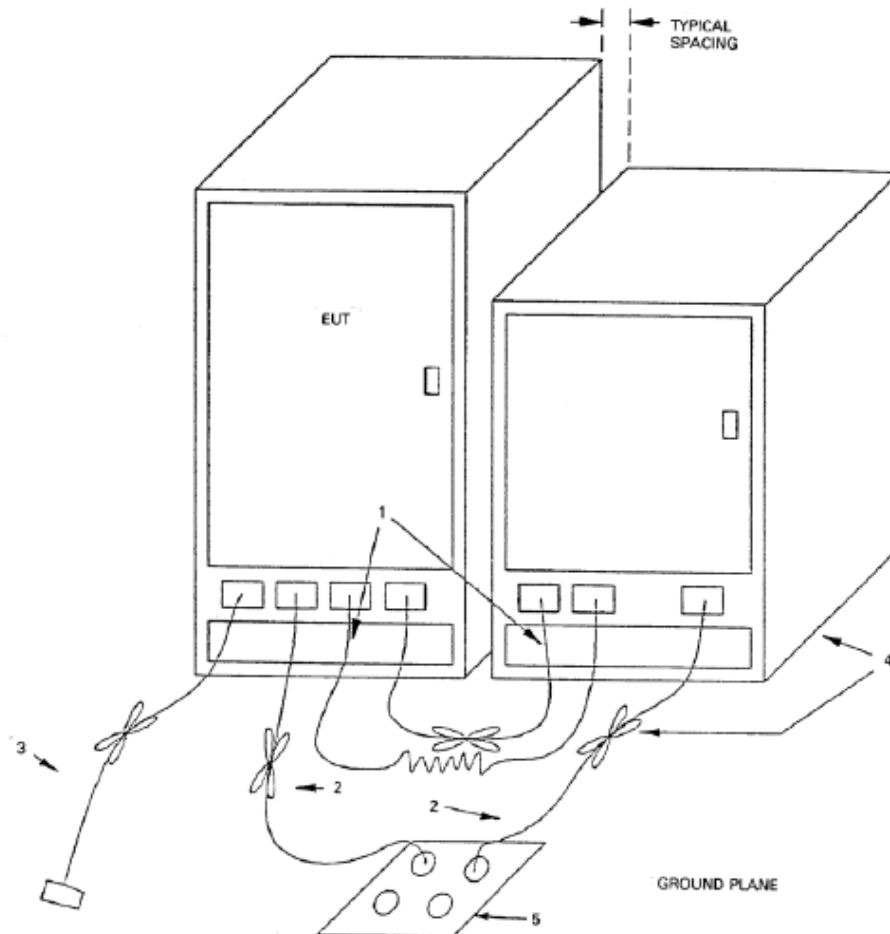

4.3 Test Setup and Test Procedure

The measurement was performed in a semi-anechoic chamber.

The distance from EUT to receiving antenna is **3** meter.

Measurement was performed according to clause 4 and clause 5 of ANSI 63.4.

Test procedure was according to clause 8.3 of ANSI 63.4.

EUT arrangement and operate condition were according to clause 6 and clause 8 of ANSI 63.4.

The bandwidth setting on R&S Test Receiver ESIB26 was 120 kHz.

The required measurement frequency range was checked.

4.4 Test Protocol

Temperature : 24 °C
Relative Humidity : 52 %

Test Curve:

30MHz~1GHz, Horizontal

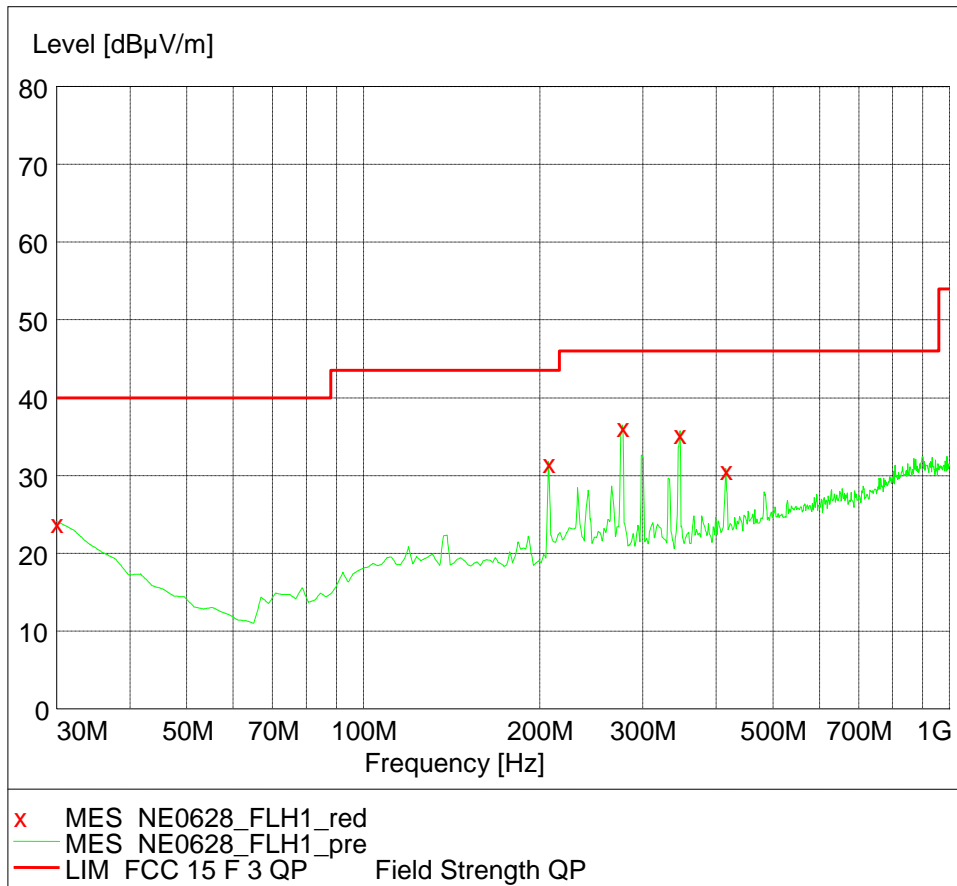

30MHz~1GHz, Vertical

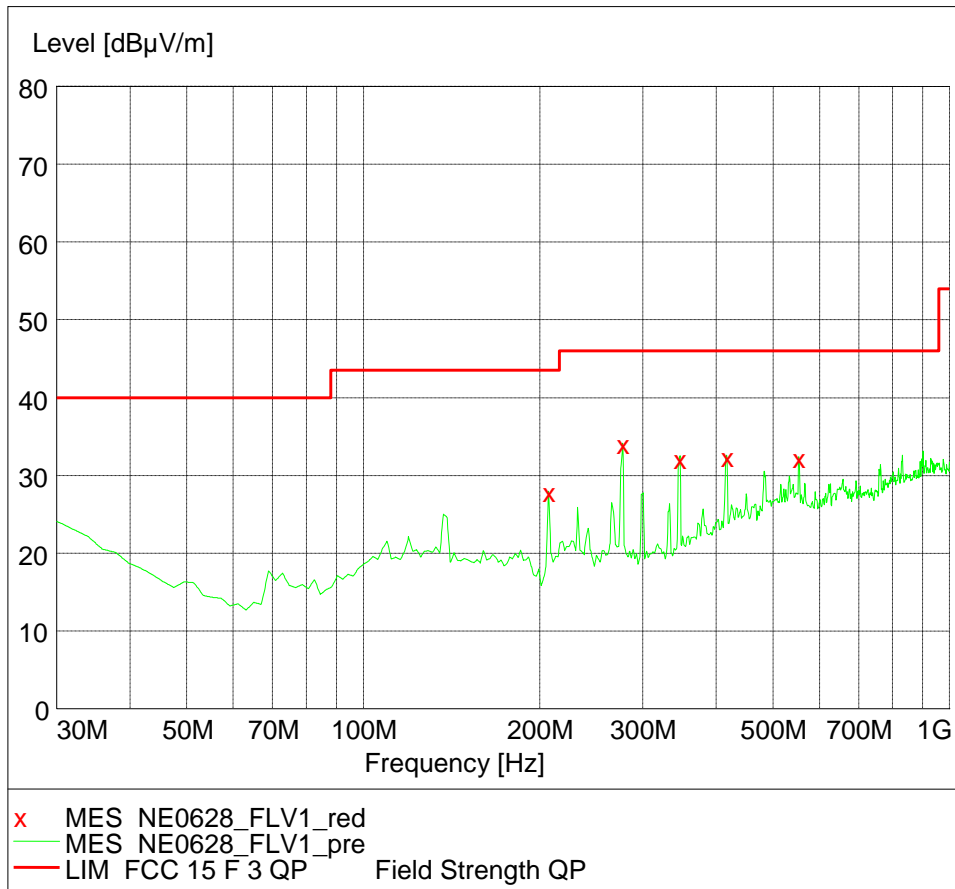

Test data:

Antenna Polarization	Frequency (MHz)	Corrected Reading (dBuV/m)	Correct Factor (dB/m)	Limit (dBuV/m)	Margin	Detector
H	206.89	31.80	12.30	43.50	11.70	PK
H	276.87	36.50	14.60	46.00	9.50	PK
H	346.85	35.50	16.70	46.00	10.50	PK
V	276.87	34.20	14.60	46.00	11.80	PK
V	346.85	32.30	16.70	46.00	13.70	PK
V	416.83	32.60	19.20	46.00	13.40	PK

- Remark: 1. Correct Factor = Antenna Factor + Cable Loss (+ Amplifier, for higher than 1GHz)
2. Corrected Reading = Original Receiver Reading + Correct Factor
 3. Margin = Limit - Corrected Reading
 4. If the PK Corrected Reading is lower than AV limit, the AV test can be elided.

Example: Assuming Antenna Factor = 30.20dB/m, Cable Loss = 2.00dB, Gain of Preamplifier = 32.00dB, Original Receiver Reading = 10.00dBuV, limit = 40.00dBuV/m.

Then Correct Factor = $30.20 + 2.00 - 32.00 = 0.20\text{dB/m}$; Corrected Reading = $10\text{dBuV} + 0.20\text{dB/m} = 10.20\text{dBuV/m}$; Margin = $40.00\text{dBuV/m} - 10.20\text{dBuV/m} = 29.80\text{dB}$.

Appendix I: Photograph of equipment under test

