

# TEST REPORT

FCC ID: 2ADYY-LJ9

Product: Mobile Phone

Model No.: LJ9

Trade Mark: TECNO

Report No.: WSCT-ANAB-R&E250300017A-15B

Issued Date: 22 May 2025

Issued for:

TECNO MOBILE LIMITED  
FLAT N 16/F BLOCK B UNIVERSAL INDUSTRIAL CENTRE 19-25 SHAN MEI  
STREET FOTAN NT HONGKONG

Issued By:

World Standardization Certification & Testing Group(Shenzhen) Co.,Ltd.  
Building A-B,Baoli'an Industrial Park,No.58 and 60,Tangtou Avenue, Shiyan  
Street, Bao'an District, Shenzhen City, Guangdong Province, China

TEL: +86-755-26996192

FAX: +86-755-86376605



**Note:** This report shall not be reproduced except in full, without the written approval of World Standardization Certification & Testing Group (Shenzhen) Co., Ltd. This document may be altered or revised by World Standardization Certification & Testing Group (Shenzhen) Co., Ltd. personnel only, and shall be noted in the revision section of the document. The test results in the report only apply to the tested sample.





## TABLE OF CONTENTS

<b>1. Test Certification</b> .....	<b>3</b>
<b>2. GENERAL DESCRIPTION OF EUT</b> .....	<b>4</b>
<b>3. Test Result Summary</b> .....	<b>5</b>
<b>4. TEST METHODOLOGY</b> .....	<b>6</b>
4.1. CONFIGURATION OF SYSTEM UNDER TEST .....	7
4.2. DESCRIPTION OF SUPPORT UNITS (CONDUCTED MODE) .....	8
<b>5. MEASUREMENT INSTRUMENTS</b> .....	<b>9</b>
<b>6. Facilities and Accreditations</b> .....	<b>10</b>
6.1. FACILITIES .....	10
6.2. ACCREDITATIONS .....	10
6.3. MEASUREMENT UNCERTAINTY .....	11
<b>7. EMC EMISSION TEST</b> .....	<b>12</b>
7.1. CONDUCTED EMISSION MEASUREMENT .....	12
7.2. TEST RESULTS .....	14
7.3. RADIATED EMISSION MEASUREMENT .....	16
<b>8. Test Setup Photographs</b> .....	<b>23</b>





Report No.: WSCT-ANAB-R&E250300017A-15B Issued Date: 22 May 2025

# 1. Test Certification

<b>Product:</b>	Mobile Phone
<b>Model No.:</b>	LJ9
<b>Additional Model:</b>	TECNO
<b>Applicant:</b>	<b>TECNO MOBILE LIMITED</b> FLAT N 16/F BLOCK B UNIVERSAL INDUSTRIAL CENTRE 19-25 SHAN MEI STREET FOTAN NT HONGKONG
<b>Manufacturer:</b>	<b>TECNO MOBILE LIMITED</b> FLAT N 16/F BLOCK B UNIVERSAL INDUSTRIAL CENTRE 19-25 SHAN MEI STREET FOTAN NT HONGKONG
<b>Date of Test:</b>	07 March 2025 to 22 May 2025
<b>Applicable Standards:</b>	FCC CFR Title 47 Part 15 Subpart B

The above equipment has been tested by World Standardization Certification & Testing Group(Shenzhen) Co., Ltd. and found compliance with the requirements set forth in the technical standards mentioned above. The results of testing in this report apply only to the product, which was tested. Other similar equipment will not necessarily produce the same results due to production tolerance and measurement uncertainties.

**Tested By:** Jiang Guanliang  
(Jiang Guanliang)

**Checked By:** Chen Xu  
(Chen Xu)

**Approved By:** Qin Shuiquan  
( Qin Shuiquan)

**Date:** 22 May 2025





Report No.: WSCT-ANAB-R&amp;E250300017A-15B Issued Date: 22 May 2025

## 2. GENERAL DESCRIPTION OF EUT

<b>Product Name:</b>	Mobile Phone
<b>Model:</b>	LJ9
<b>Trade Mark:</b>	TECNO
<b>Operating Voltage:</b>	Adapter: U700TSA Input: 100-240V~50/60Hz 2.0A Output: 5.0V=3.0A 15.0W or 5.0-10.0V=7.0A MAX or 11.0V=6.4A MAX or 4.0-20.0V=3.5A 70.0W MAX Rechargeable Li-ion Polymer Battery: BL-58GT Rated Voltage: 3.91V Rated Capacity: 5850mAh/22.88Wh Typical Capacity: 6000mAh/23.46Wh Limited Charge Voltage: 4.50V
<b>Remark:</b>	N/A.

Note: 1. N/A stands for no applicable.



### 3. Test Result Summary

Requirement	CFR 47 Section	Result
CONDUCTED EMISSION	§15.107	PASS
RADIATED EMISSION	§15.109	PASS

**Note:**

1. PASS: Test item meets the requirement.
2. Fail: Test item does not meet the requirement.
3. N/A: Test case does not apply to the test object.
4. The test result judgment is decided by the limit of test standard.





## 4. TEST METHODOLOGY

To investigate the maximum EMI emission characteristics generates from EUT, the test system was pre-scanning tested base on the consideration of following EUT operation mode or test configuration mode which possible have effect on EMI emission level. Each of these EUT operation mode(s) or test configuration mode(s) mentioned above was evaluated respectively.

Pretest Mode	Description
Mode 1	Video Recording
Model 2	Video Playing
Mode 3	Exchange data with computer
Mode 4	FM



Report No.: WSCT-ANAB-R&E250300017A-15B Issued Date: 22 May 2025

### 4.1. CONFIGURATION OF SYSTEM UNDER TEST

Mode 1&2&4

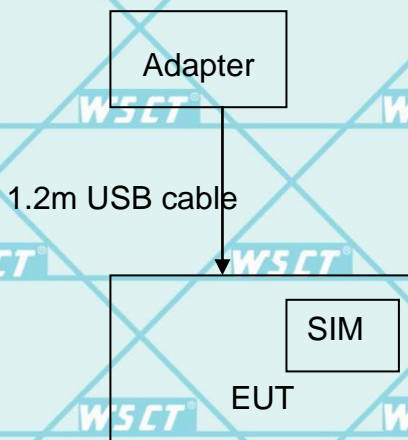

Mode 3:



(EUT: Mobile Phone)

I/O Port of EUT			
I/O Port Type	Q'TY	Cable	Tested with
Power	1	1.5m USB cable, unshielded	1





## 4.2. DESCRIPTION OF SUPPORT UNITS (CONDUCTED MODE)

The EUT has been tested as an independent unit together with other necessary accessories or support units. The following support units or accessories were used to form a representative test configuration during the tests.

Item	Equipment	Mfr/Brand	Model/Type No.	Series No.	Note
1	Adapter	/	U700TSA	/	/
2	PC	Lenovo	TP00067A	PF-OGT3MS	/

Note:

- (1) The support equipment was authorized by Declaration of Confirmation.
- (2) For detachable type I/O cable should be specified the length in cm in 『Length』 column.





## 5. MEASUREMENT INSTRUMENTS

Kind of Equipment	Manufacturer	Type No.	Serial No.	Last Calibrated	Calibrated until
Test software	--	EZ-EMC	CON-03A	--	--
ESCI Test Receiver	R&S	ESCI	100005	11/05/2024	11/04/2025
LISN	AFJ	LS16	16010222119	11/05/2024	11/04/2025
LISN(EUT)	Mestec	AN3016	04/10040	11/05/2024	11/04/2025
pre-amplifier	CDSI	PAP-1G18-38	--	11/05/2024	11/04/2025
System Controller	CT	SC100	-	11/05/2024	11/04/2025
Bi-log Antenna	Chase	CBL6111C	2576	11/05/2024	11/04/2025
Spectrum analyzer	R&S	FSU26	200409	11/05/2024	11/04/2025
Horn Antenna	SCHWARZBECK	9120D	1141	11/05/2024	11/04/2025
Bi-log Antenna	SCHWARZBECK	VULB9168	01488	7/29/2024	7/28/2025
Pre Amplifier	H.P.	HP8447E	2945A02715	11/05/2024	11/04/2025
9*6*6 Anechoic	--	--	--	11/05/2024	11/04/2025





## 6. Facilities and Accreditations

### 6.1. Facilities

All measurement facilities used to collect the measurement data are located at **Building A-B, Baoli'an Industrial Park, No.58 and 60, Tangtou Avenue, Shiyan Street, Bao'an District, Shenzhen City, Guangdong Province, China** of the World Standardization Certification & Testing Group (Shenzhen) Co., Ltd.

The sites are constructed in conformance with the requirements of ANSI C63.4 and CISPR Publication 22. All receiving equipment conforms to CISPR Publication 16-1, "Radio Interference Measuring Apparatus and Measurement Methods."

### 6.2. ACCREDITATIONS

**ANAB - Certificate Number: AT-3951**

The EMC Laboratory has been accredited by the American Association for Laboratory Accreditation (ANAB). Certification Number: AT-3951





### 6.3. Measurement Uncertainty

The reported uncertainty of measurement  $y \pm U$ , where expanded uncertainty  $U$  is based on a standard uncertainty multiplied by a coverage factor of  $k=2$ , providing a level of confidence of approximately 95 %.

No.	Item	MU
1	Conducted Emission Test	$\pm 3.2\text{dB}$
2	RF power, conducted	$\pm 0.16\text{dB}$
3	Spurious emissions, conducted	$\pm 0.21\text{dB}$
4	All emissions, radiated(<1GHz)	$\pm 3.3\text{dB}$
5	All emissions, radiated(>1GHz)	$\pm 4.7\text{dB}$
6	Temperature	$\pm 0.5^\circ\text{C}$
7	Humidity	$\pm 2.0\%$





## 7. EMC EMISSION TEST

### 7.1. CONDUCTED EMISSION MEASUREMENT

#### 7.1.1. POWER LINE CONDUCTED EMISSION LIMITS

FREQUENCY (MHz)	Class A (dBuV)		Class B (dBuV)		Standard
	Quasi-peak	Average	Quasi-peak	Average	
0.15 -0.5	79.00	66.00	66 - 56 *	56 - 46 *	FCC
0.50 -5.0	73.00	60.00	56.00	46.00	FCC
5.0 -30.0	73.00	60.00	60.00	50.00	FCC

Note:

- (1) The tighter limit applies at the band edges.
- (2) The limit of " \* " marked band means the limitation decreases linearly with the logarithm of the frequency in the range.

The following table is the setting of the receiver

Receiver Parameters	Setting
Attenuation	10 dB
Start Frequency	0.15 MHz
Stop Frequency	30 MHz
IF Bandwidth	9 kHz



Report No.: WSCT-ANAB-R&E250300017A-15B Issued Date: 22 May 2025

**TEST PROCEDURE**

- a. The EUT was placed 0.4 meters from the horizontal ground plane with EUT being connected to the power mains through a line impedance stabilization network (LISN). All other support equipments powered from additional LISN(s). The LISN provide 50 Ohm/ 50uH of coupling impedance for the measuring instrument.
- b. Interconnecting cables that hang closer than 40 cm to the ground plane shall be folded back and forth in the center forming a bundle 30 to 40 cm long.
- c. I/O cables that are not connected to a peripheral shall be bundled in the center. The end of the cable may be terminated, if required, using the correct terminating impedance. The overall length shall not exceed 1 m.
- d. LISN at least 80 cm from nearest part of EUT chassis.
- e. For the actual test configuration, please refer to the related Item –EUT Test Photos.

**TEST SETUP**

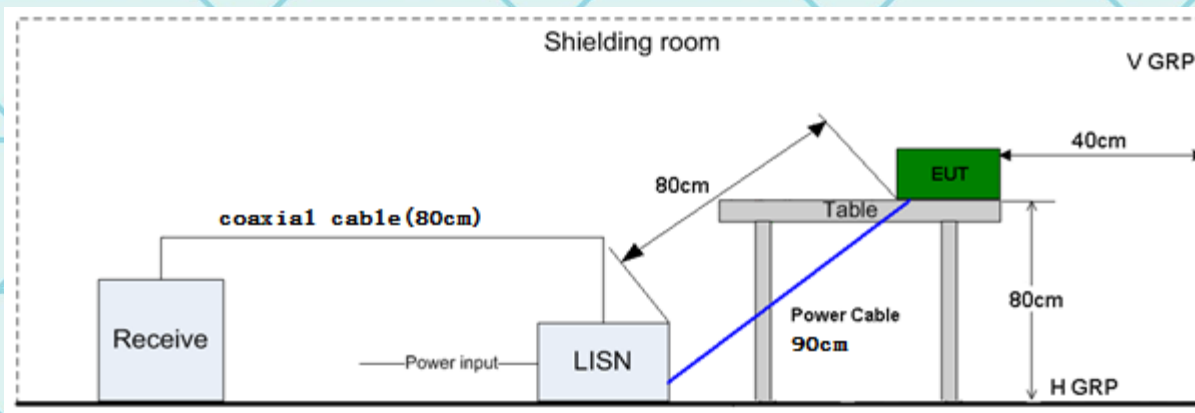



## 7.2. Test Results

Temperature	20 °C	Relative Humidity	48%
Pressure	1010 hPa	Test Mode	Mode 2(the worst case)

### Conducted Emission on Line Terminal of the power line (150 kHz to 30MHz)

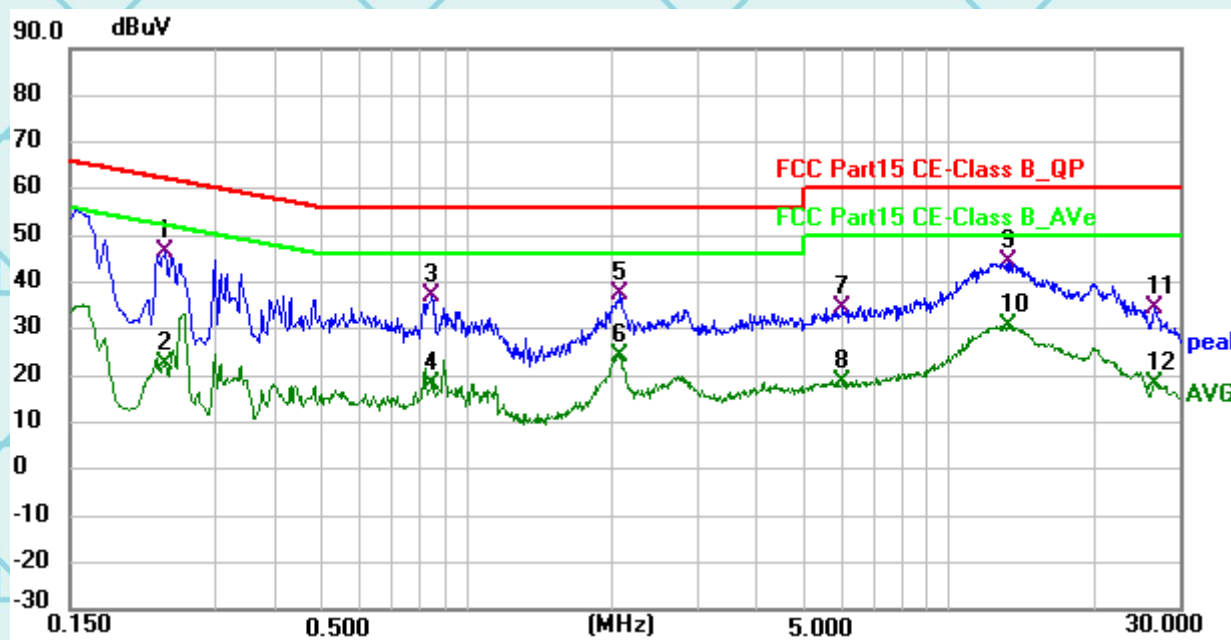

No.	Frequency (MHz)	Reading (dBuV)	Factor (dB)	Level (dBuV)	Limit (dBuV)	Margin (dB)	Detector
1	0.2355	25.67	20.67	46.34	62.25	-15.91	QP
2	0.2355	1.72	20.67	22.39	52.25	-29.86	AVG
3	0.8475	16.43	20.60	37.03	56.00	-18.97	QP
4	0.8475	-2.19	20.60	18.41	46.00	-27.59	AVG
5	2.0850	16.97	20.61	37.58	56.00	-18.42	QP
6	2.0850	3.53	20.61	24.14	46.00	-21.86	AVG
7	5.9955	13.77	20.54	34.31	60.00	-25.69	QP
8	5.9955	-1.88	20.54	18.66	50.00	-31.34	AVG
9 *	13.2045	23.92	20.27	44.19	60.00	-15.81	QP
10	13.2045	10.56	20.27	30.83	50.00	-19.17	AVG
11	26.6955	13.82	20.79	34.61	60.00	-25.39	QP
12	26.6955	-2.40	20.79	18.39	50.00	-31.61	AVG





Report No.: WSCT-ANAB-R&E250300017A-15B Issued Date: 22 May 2025

### Conducted Emission on Neutral Terminal of the power line (150 kHz to 30MHz)

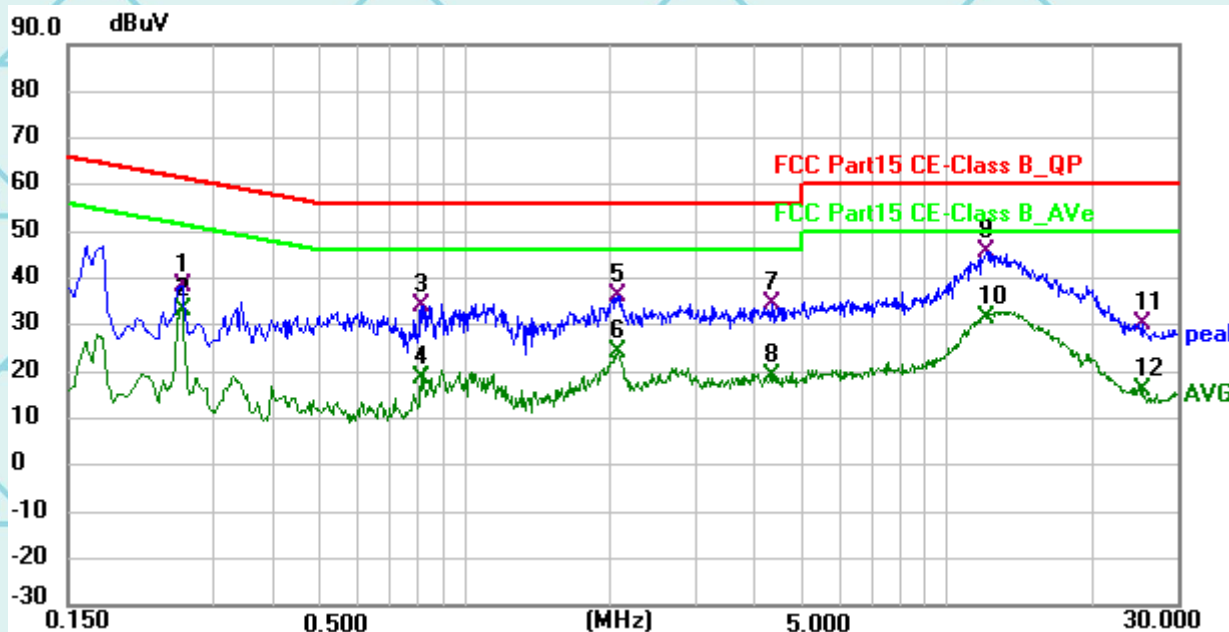

No.	Frequency (MHz)	Reading (dBuV)	Factor (dB)	Level (dBuV)	Limit (dBuV)	Margin (dB)	Detector
1	0.2580	17.65	20.66	38.31	61.50	-23.19	QP
2	0.2580	12.39	20.66	33.05	51.50	-18.45	AVG
3	0.8160	13.66	20.59	34.25	56.00	-21.75	QP
4	0.8160	-1.83	20.59	18.76	46.00	-27.24	AVG
5	2.0760	15.54	20.61	36.15	56.00	-19.85	QP
6	2.0760	3.73	20.61	24.34	46.00	-21.66	AVG
7	4.3485	13.76	20.58	34.34	56.00	-21.66	QP
8	4.3485	-1.32	20.58	19.26	46.00	-26.74	AVG
9 *	12.0750	25.44	20.33	45.77	60.00	-14.23	QP
10	12.0750	11.27	20.33	31.60	50.00	-18.40	AVG
11	25.4400	9.76	20.65	30.41	60.00	-29.59	QP
12	25.4400	-4.60	20.65	16.05	50.00	-33.95	AVG

**Note1:**

Freq. = Emission frequency in MHz

Reading level (dBuV) = Receiver reading

Corr. Factor (dB) = LISN Factor + Cable loss

Measurement (dBuV) = Reading level (dBuV) + Corr. Factor (dB)

Limit (dBuV) = Limit stated in standard

Margin (dB) = Measurement (dBuV) – Limits (dBuV)

Q.P. =Quasi-Peak AVG =average

\* is meaning the worst frequency has been tested in the frequency range 150 kHz to 30MHz.





### 7.3. RADIATED EMISSION MEASUREMENT

#### 7.3.1. Radiated Emission Limits

The field strength of radiated emissions from unintentional radiators at a distance of 3 meters shall not exceed the following values:

Frequencies (MHz)	Field Strength (microvolts/meter)	Measurement Distance (meters)
0.009~0.490	2400/F(KHz)	300
0.490~1.705	24000/F(KHz)	30
1.705~30.0	30	30
30~88	100	3
88~216	150	3
216~960	200	3
Above 960	500	3

#### LIMITS OF RADIATED EMISSION MEASUREMENT (Above 1000MHz)

FREQUENCY (MHz)	Limit (dBuV/m) (at 3M)	
	PEAK	AVERAGE
Above 1000	74	54

Notes:

- (1) The limit for radiated test was performed according to FCC PART 15B.
- (2) The tighter limit applies at the band edges.
- (3) Emission level (dBuV/m)=20log Emission level (uV/m).

Spectrum Parameter	Setting
Attenuation	Auto
Start Frequency	1000 MHz
Stop Frequency	10th carrier harmonic
RB / VB (emission in restricted band)	1 MHz / 1 MHz for Peak, 1 MHz / 1Hz for Average

Receiver Parameter	Setting
Attenuation	Auto
Start ~ Stop Frequency	9kHz~150kHz / RB 200Hz for QP
Start ~ Stop Frequency	150kHz~30MHz / RB 9kHz for QP
Start ~ Stop Frequency	30MHz~1000MHz / RB 120kHz for QP





## TEST PROCEDURE

- a. The measuring distance of at 3 m shall be used for measurements at frequency up to 1GHz. For frequencies above 1GHz, any suitable measuring distance may be used.
- b. The EUT was placed on the top of a rotating table 0.8 meters above the ground at a 3 meter open area test site. The table was rotated 360 degrees to determine the position of the highest radiation.
- c. The height of the equipment or of the substitution antenna shall be 0.8 m; the height of the test antenna shall vary between 1 m to 4 m. Both horizontal and vertical polarizations of the antenna are set to make the measurement.
- d. The initial step in collecting conducted emission data is a spectrum analyzer peak detector mode pre-scanning the measurement frequency range. Significant peaks are then marked and then Quasi Peak detector mode re-measured.
- e. If the Peak Mode measured value compliance with and lower than Quasi Peak Mode Limit, the EUT shall be deemed to meet QP Limits and then no additional QP Mode measurement performed.
- f. For the actual test configuration, please refer to the related Item –EUT Test Photos.



### TEST SETUP

(A) Radiated Emission Test-Up Frequency 30MHz~1GHz

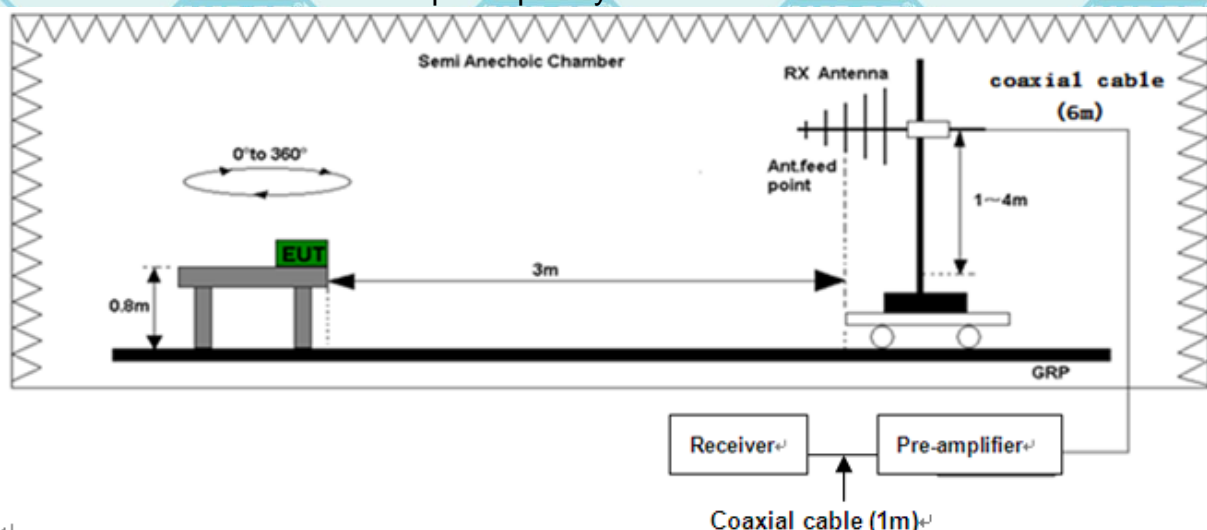

(B) Radiated Emission Test-Up Frequency Above 1GHz

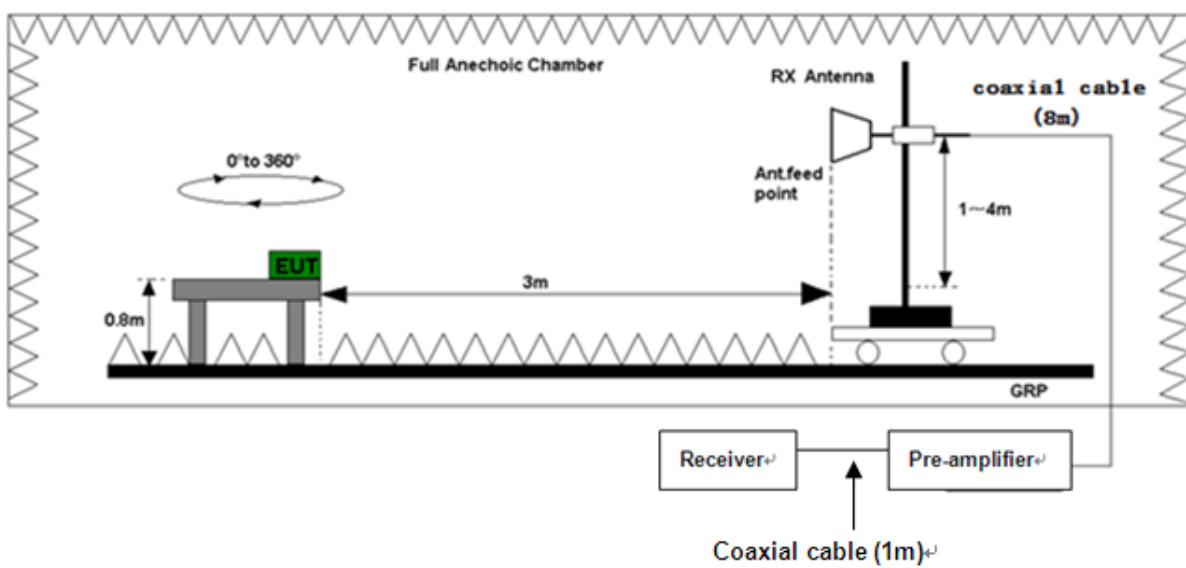



**7.3.2. Test Results**

Temperature	20 °C	Relative Humidity	48%
Pressure	1010 hPa	Test Mode	Mode 2(the worst case)

Please refer to following diagram for individual

**Below 1GHz**

Horizontal:

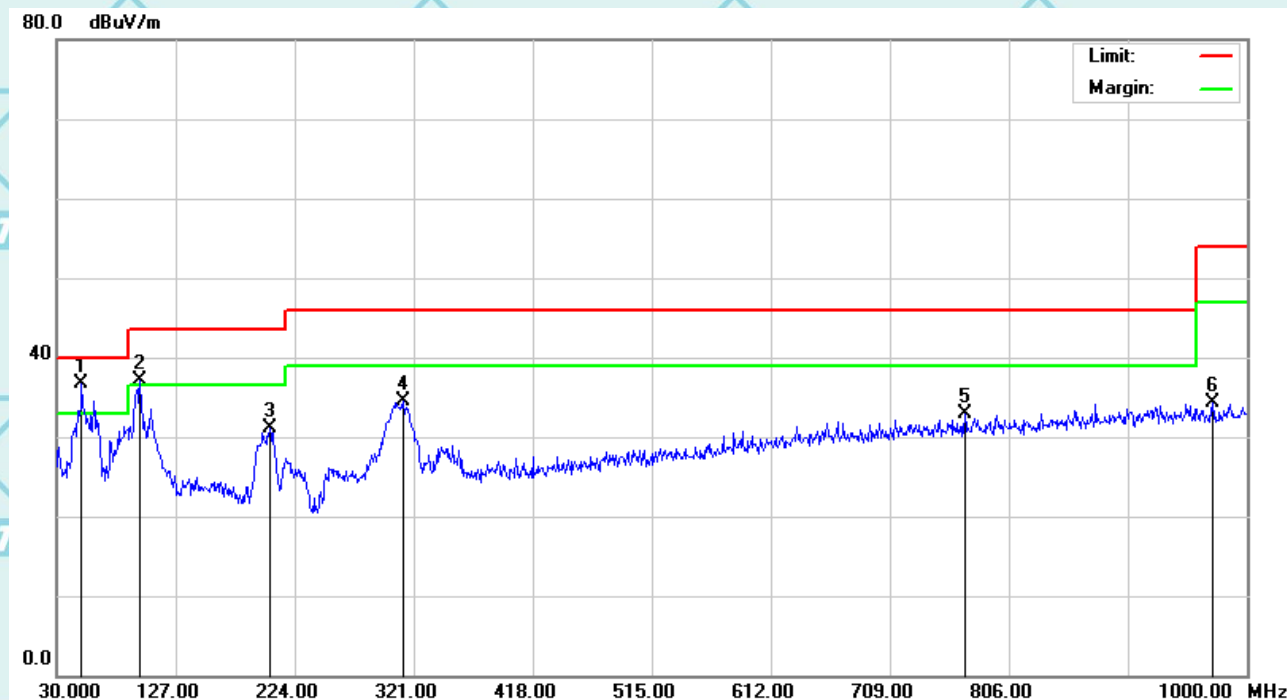

No.	Mk.	Freq. MHz	Reading Level dBuV	Correct Factor dB	Measure- ment dBuV/m	Limit dBuV/m	Over dB	Detector
1	*	50.3700	38.75	-2.14	36.61	40.00	-3.39	QP
2	!	97.9000	42.79	-5.68	37.11	43.50	-6.39	QP
3		203.6300	37.02	-5.88	31.14	43.50	-12.36	QP
4		312.2700	36.73	-2.14	34.59	46.00	-11.41	QP
5		770.1100	26.94	5.99	32.93	46.00	-13.07	QP
6		971.8700	25.97	8.28	34.25	54.00	-19.75	QP





Vertical:

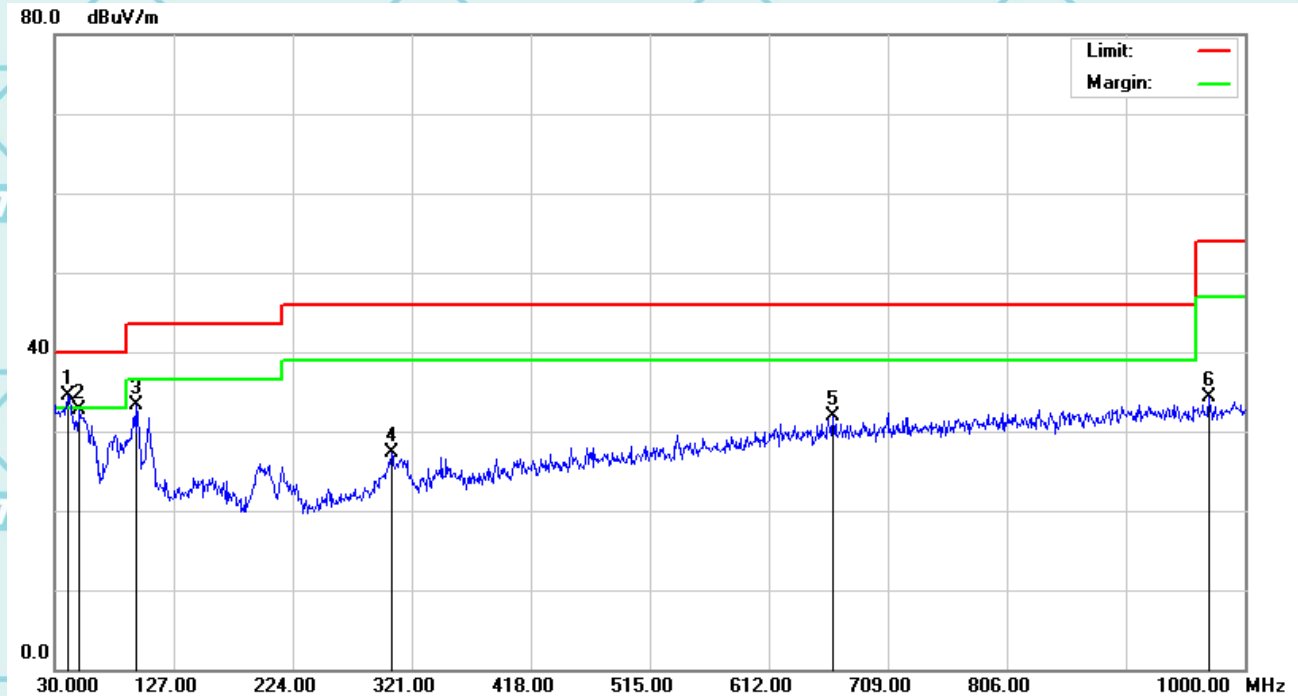

No.	Mk.	Freq. MHz	Reading Level dBuV	Correct Factor dB	Measure- ment dBuV/m	Limit dBuV/m	Over dB	Detector
1	*	40.6699	36.01	-1.52	34.49	40.00	-5.51	QP
2		50.3700	34.87	-2.14	32.73	40.00	-7.27	QP
3		95.9600	39.07	-5.76	33.31	43.50	-10.19	QP
4		304.5100	29.66	-2.41	27.25	46.00	-18.75	QP
5		664.3800	26.96	4.94	31.90	46.00	-14.10	QP
6		970.9000	25.97	8.26	34.23	54.00	-19.77	QP

Note1:

- Freq. = Emission frequency in MHz
- Reading level (dBuV) = Receiver reading
- Corr. Factor (dB) = Antenna factor + Cable loss - Amplifier factor.
- Measurement (dBuV) = Reading level (dBuV) + Corr. Factor (dB)
- Limit (dBuV) = Limit stated in standard
- Margin (dB) = Measurement (dBuV) – Limits (dBuV)





### TEST RESULTS

Above 1GHz(1~6GHz) :( Mode 2—worst case)

Note: The spurious above 6G is noise only, do not show on the report.

Horizontal:

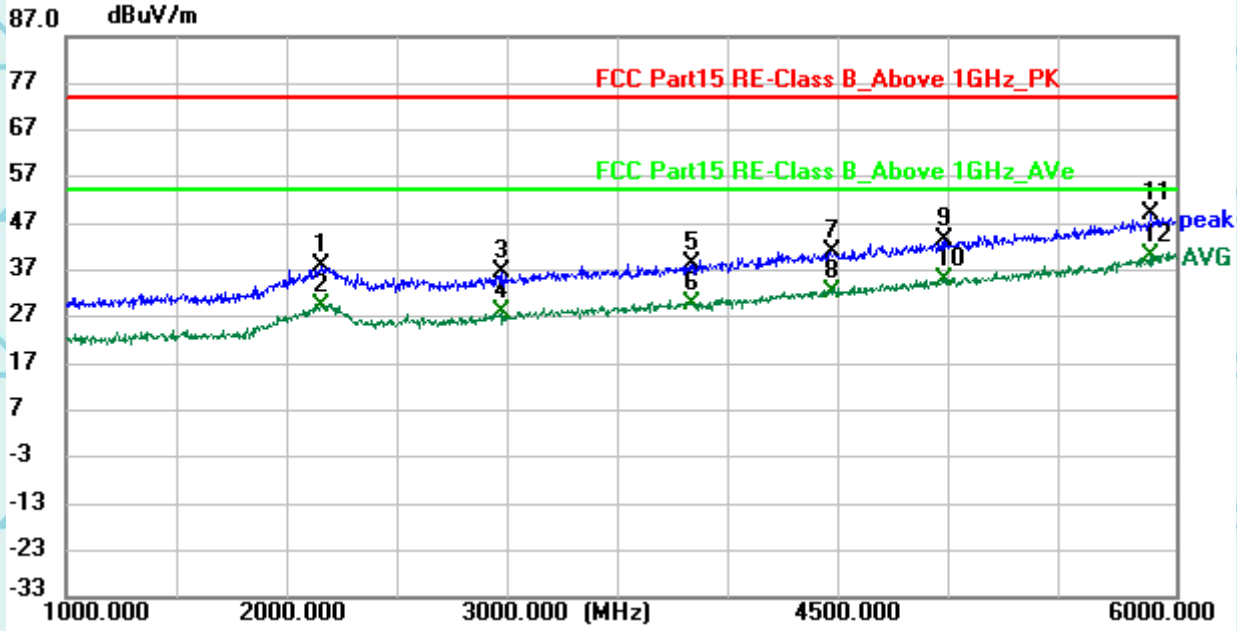

No.	Frequency (MHz)	Reading (dBuV)	Factor (dB/m)	Level (dBuV/m)	Limit (dBuV/m)	Margin (dB)	Detector
1	2151.250	39.30	-1.18	38.12	74.00	-35.88	peak
2	2151.250	30.37	-1.18	29.19	54.00	-24.81	AVG
3	2964.375	39.11	-2.37	36.74	74.00	-37.26	peak
4	2964.375	30.25	-2.37	27.88	54.00	-26.12	AVG
5	3821.250	37.96	0.22	38.18	74.00	-35.82	peak
6	3821.250	29.52	0.22	29.74	54.00	-24.26	AVG
7	4446.250	37.96	2.79	40.75	74.00	-33.25	peak
8	4446.250	29.42	2.79	32.21	54.00	-21.79	AVG
9	4957.500	38.43	5.05	43.48	74.00	-30.52	peak
10	4957.500	29.95	5.05	35.00	54.00	-19.00	AVG
11	5890.000	40.02	9.07	49.09	74.00	-24.91	peak
12 *	5890.000	30.84	9.07	39.91	54.00	-14.09	AVG





Report No.: WSCT-ANAB-R&E250300017A-15B Issued Date: 22 May 2025

Vertical:

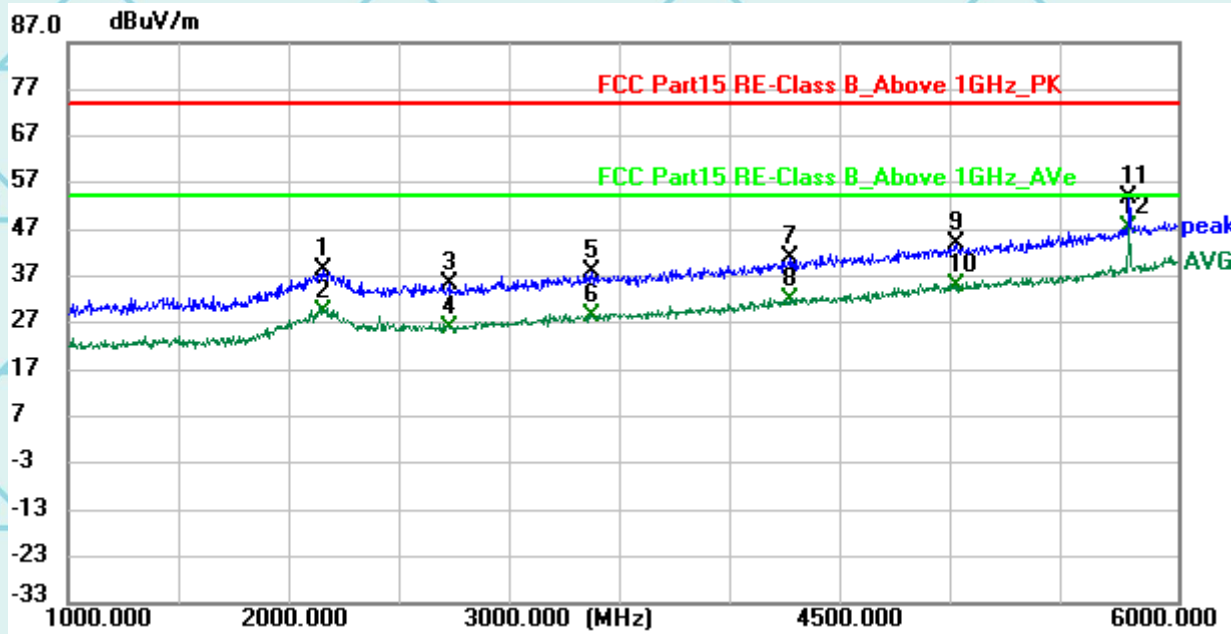

No.	Frequency (MHz)	Reading (dBuV)	Factor (dB/m)	Level (dBuV/m)	Limit (dBuV/m)	Margin (dB)	Detector
1	2160.000	39.70	-1.28	38.42	74.00	-35.58	peak
2	2160.000	30.54	-1.28	29.26	54.00	-24.74	AVG
3	2718.750	38.53	-3.02	35.51	74.00	-38.49	peak
4	2718.750	28.78	-3.02	25.76	54.00	-28.24	AVG
5	3364.375	39.29	-1.45	37.84	74.00	-36.16	peak
6	3364.375	29.84	-1.45	28.39	54.00	-25.61	AVG
7	4253.750	38.92	1.99	40.91	74.00	-33.09	peak
8	4253.750	29.88	1.99	31.87	54.00	-22.13	AVG
9	5009.375	38.63	5.27	43.90	74.00	-30.10	peak
10	5009.375	29.69	5.27	34.96	54.00	-19.04	AVG
11	5783.125	45.63	8.34	53.97	74.00	-20.03	peak
12 *	5783.125	38.96	8.34	47.30	54.00	-6.70	AVG

Remark:

All emissions not reported were more than 20dB below the specified limit or in the noise floor.

Freq. = Emission frequency in MHz

Factor = Antenna Factor + Cable Loss – Pre-amplifier.

Over= Emission Level - Limit.

All the x/y/z orientation has been investigated, and only worst case is presented in this report.





## 8. Test Setup Photographs

Please refer to Annex "Set Up Photos-15B" for test setup photos

**\*\*\*\*\*END OF REPORT\*\*\*\*\***

