



FCC/ISED - TEST REPORT

Report Number : **68.710.24.0093.01** Date of Issue: 2024-04-10

Model/HVIN : **T10 Pro**

Product Type : Robotic vacuum cleaner

Applicant : Shenzhen Topband Co.,Ltd

Address : Topband Industrial Park, LiYuan Industrial Zone, ShiYan Town,

Bao'An District, 518108 Shenzhen,

PEOPLE'S REPUBLIC OF CHINA

Manufacturer : Shenzhen Topband Co.,Ltd

Address : Topband Industrial Park, LiYuan Industrial Zone, ShiYan Town,

Bao'An District, 518108 Shenzhen,

PEOPLE'S REPUBLIC OF CHINA

Test Result : **Positive** **Negative**

Total pages including Appendices : 71

Any use for advertising purposes must be granted in writing. This technical report may only be quoted in full. This report is the result of a single examination of the object in question and is not generally applicable evaluation of the quality of other products in regular production. For further details, please see testing and certification regulation chapter A-3.4.



1 Table of Contents

- 1 Table of Contents 2
- 2 Details about the Test Laboratory 3
- 3 Description of the Equipment Under Test..... 4
- 4 Summary of Test Standards..... 5
- 5 Summary of Test Results 6
- 6 General Remarks 7
- 7 Test Setups 8
- 8 Systems Test Configuration 10
- 9 Technical Requirement 11
 - 9.1 Conducted Emission..... 11
 - 9.2 Conducted Peak Output Power & EIRP..... 14
 - 9.3 20 dB Bandwidth and 99% Occupied Bandwidth..... 20
 - 9.4 Carrier Frequency Separation 31
 - 9.5 Number of Hopping Frequencies 34
 - 9.6 Dwell Time 37
 - 9.7 Spurious RF Conducted Emissions 47
 - 9.8 Band Edge Testing 53
 - 9.9 Spurious Radiated Emissions for Transmitter..... 60
- 10 Test Equipment List 70
- 11 System Measurement Uncertainty 71

2 Details about the Test Laboratory

Details about the Test Laboratory

Test Site 1

Company name: TÜV SÜD Certification and Testing (China) Co., Ltd. Shenzhen Branch
Building 12 & 13, Zhiheng Wisdomland Business Park, Guankou Erlu, Nantou, Nanshan District, Shenzhen, Guangdong, China

Telephone: 86 755 8828 6998

Fax: 86 755 8828 5299

FCC Registration No.: 514049

FCC Designation Number: CN5009

ISED CAB identifier: CN0077

IC Registration No.: 10320A

3 Description of the Equipment Under Test

Product:	Robotic vacuum cleaner
Model no.:	T10 Pro
Product Marketing Name (PMN):	Robotic vacuum cleaner
Hardware Version Identification No. (HVIN):	T10 Pro
FCC ID:	2ADDW-T10PRO
IC:	23804-T10PRO
Options and accessories:	Power supply Manufacturer: SHENZHEN KEYU POWER SUPPLY TECHNOLOGY CO., LTD Model: KA2401A-2001200US Input: 100-240VAC, 50/60Hz, 0.65A Max. Output: 20VDC, 1200mA
Ratings:	20VDC, 1.2A
RF Transmission Frequency:	2402MHz - 2480MHz for BT BR/EDR
No. of Operated Channel:	79 for BT BR/EDR
Modulation:	GFSK, Pi/4DQPSK, 8DPSK
Antenna Type:	Integrated FPC antenna
Antenna Gain:	4.5 dBi for Bluetooth
Description of the EUT:	The EUT is a Robotic vacuum cleaner supports Wi-Fi and BT functions: 2412MHz - 2462MHz for 2.4GHz Wi-Fi; 2402MHz - 2480MHz for BLE (1Mbps); 2402MHz - 2480MHz for BT BR/EDR.
Remark:	This report is only for BT BR/EDR.

NOTE 1: The above EUT's information is declared by manufacturer. Please refer to the specifications or user's manual for more detailed description.

4 Summary of Test Standards

Test Standards	
FCC Part 15 Subpart C 10-1-2023 Edition	PART 15 - RADIO FREQUENCY DEVICES Subpart C - Intentional Radiators
RSS-Gen Issue 5 April 2018 + Amendment 1 March 2019 + Amendment 2 February 2021	General Requirements for Compliance of Radio Apparatus
RSS-247 Issue 3 August 2023	Digital Transmission Systems (DTSS), Frequency Hopping Systems (FHSS) and License-Exempt Local Area Network (LE-LAN) Devices

All the test methods were according to KDB 558074 D01 15.247 Meas Guidance v05r02 Measurement Guidance and ANSI C63.10-2013.

5 Summary of Test Results

Technical Requirements						
FCC Part 15 Subpart C/ RSS-247 Issue 3/RSS-Gen Issue 5						
Test Condition	Test Site	Test Result			Test Environment	
		Pass	Fail	N/A		
§15.207& RSS-Gen 8.8	Conducted emission AC power port	Site 1	<input checked="" type="checkbox"/>	<input type="checkbox"/>	<input type="checkbox"/>	T: 23.1°C H: 51.2%
§15.247(b)(1)	Conducted peak output power	Site 1	<input checked="" type="checkbox"/>	<input type="checkbox"/>	<input type="checkbox"/>	T: 23.4°C H: 52.7%
RSS-247 5.4(b)	Conducted peak output power and Equivalent Isotropic Radiated Power	Site 1	<input checked="" type="checkbox"/>	<input type="checkbox"/>	<input type="checkbox"/>	T: 23.4°C H: 52.7%
§15.247(a)(1) & RSS-247 5.1(a) & RSS-Gen 6.7	20dB bandwidth and 99% occupied bandwidth	Site 1	<input checked="" type="checkbox"/>	<input type="checkbox"/>	<input type="checkbox"/>	T: 23.4°C H: 52.7%
§15.247(a)(1) & RSS-247 5.1(b)	Carrier channel frequency separation	Site 1	<input checked="" type="checkbox"/>	<input type="checkbox"/>	<input type="checkbox"/>	T: 23.7°C H: 52.7%
§15.247(a)(1)(iii) & RSS-247 5.1(d)	Number of hopping frequencies	Site 1	<input checked="" type="checkbox"/>	<input type="checkbox"/>	<input type="checkbox"/>	T: 23.8°C H: 52.7%
§15.247(a)(1)(iii) & RSS-247 5.1(d)	Dwell Time - Average Time of Occupancy	Site 1	<input checked="" type="checkbox"/>	<input type="checkbox"/>	<input type="checkbox"/>	T: 23.1°C H: 58.0%
§15.247(d) & RSS-247 5.5	Spurious RF conducted emissions	Site 1	<input checked="" type="checkbox"/>	<input type="checkbox"/>	<input type="checkbox"/>	T: 23.2°C H: 58.1%
§15.247(d) & RSS-247 5.5	Band edge	Site 1	<input checked="" type="checkbox"/>	<input type="checkbox"/>	<input type="checkbox"/>	T: 23.1°C H: 58.0%
§15.247(d) & §15.209 & §15.205 & RSS-247 5.5 & RSS-Gen 6.13	Spurious radiated emissions for transmitter	Site 1	<input checked="" type="checkbox"/>	<input type="checkbox"/>	<input type="checkbox"/>	T: 23.2°C H: 58.1%
§15.203 & RSS-Gen 6.8	Antenna requirement	See note 2	<input checked="" type="checkbox"/>	<input type="checkbox"/>	<input type="checkbox"/>	---

Note 1: N/A=Not Applicable.

Note 2: The EUT uses an Integrated FPC antenna, which gains are 4.5dBi for Bluetooth. In accordance with §15.203 and RSS-Gen 6.8, it is considered sufficiently to comply with the provisions of this section.

Note 3: T: Temperature, H: Humidity.

6 General Remarks

Remarks

This submittal(s) (test report) is intended for FCC ID: 2ADDW-T10PRO, complies with Section 15.207, 15.209, 15.205, 15.247 of the FCC Part 15, Subpart C rules.

This submittal(s) (test report) is intended for IC: 23804-T10PRO, complies with RSS-247 and RSS-Gen.

SUMMARY:

All tests according to the regulations cited on page 5 were

- Performed

- **Not** Performed

The Equipment Under Test

- **Fulfills** the general approval requirements.

- **Does not** fulfill the general approval requirements.

Sample Received Date: 2024-02-18

Testing Start Date: 2024-02-22

Testing End Date: 2024-02-27

- TÜV SÜD Certification and Testing (China) Co., Ltd. Shenzhen Branch -

Reviewed by:

Prepared by:

Tested by:



Jessie He
Project Manager

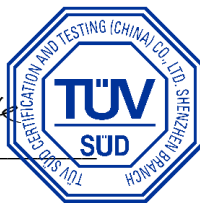

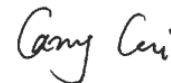

Myron Yu
Project Engineer



Carry Cai
Test Engineer

7 Test Setups

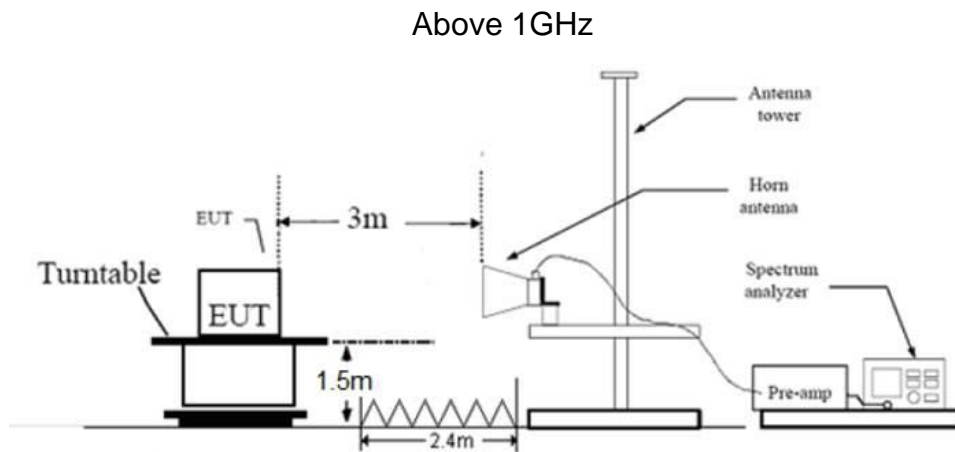
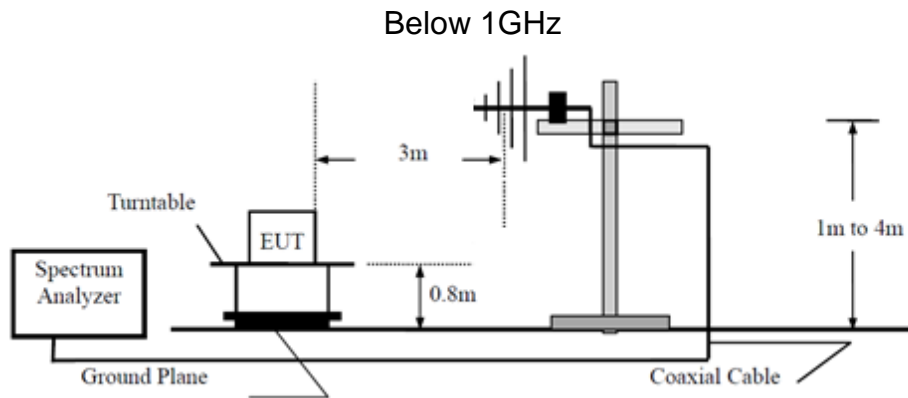
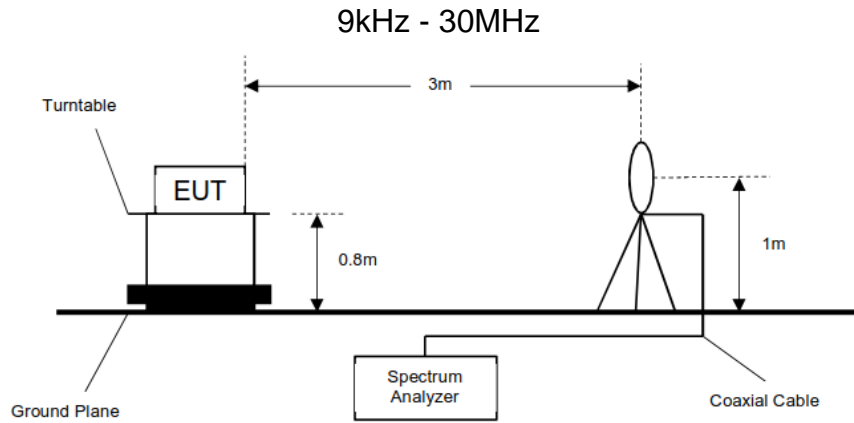
7.1 Radiated test setups



7.2 Conducted RF test setups

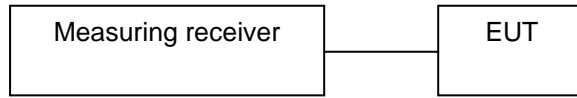

7.3 AC Power Line Conducted Emission test setups

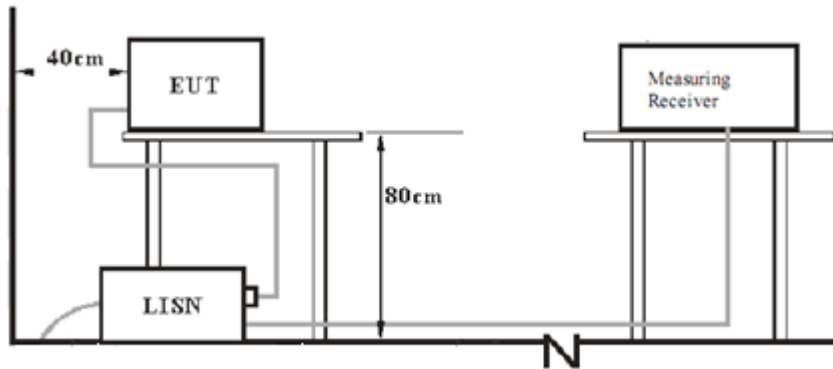

8 Systems Test Configuration

Auxiliary Equipment Used during Test:

DESCRIPTION	MODEL NO.	MANUFACTURER	S/N
Laptop	X220	ThinkPad	EMC-158

Test software information:

Test Software Version	ADB tool	
Modulation	Setting TX Power	Packet Type
GFSK	Default parameters	PRBS9
$\pi/4$ -DQPSK	Default parameters	PRBS9
8DPSK	Default parameters	PRBS9

The system was configured to hopping mode and non-hopping mode.

Hopping mode: typical working mode (normal hopping status)

Non-hopping mode: The system was configured to operate at a signal channel transmitting. The test software allows the configuration and operation at the worst-case duty and the highest transmit power.

9 Technical Requirement

9.1 Conducted Emission

Test Method

1. The EUT was placed 0.4 meter from the conducting wall of the shielding room was kept at least 80 centimeters from any other grounded conducting surface.
2. Connect EUT to the power mains through a line impedance stabilization network (LISN).
3. All the support units are connecting to the other LISN.
4. The LISN provides 50 ohm coupling impedance for the measuring instrument.
5. Both sides of AC line were checked for maximum conducted interference.
6. The frequency range from 150 kHz to 30 MHz was searched.
7. Set the test-receiver system to Peak Detect Function and specified bandwidth (IF Bandwidth = 9kHz) with Maximum Hold Mode. Then measurement is also conducted by Average Detector and Quasi-Peak Detector Function respectively.

Limit

Frequency MHz	QP Limit dB μ V	AV Limit dB μ V
0.150-0.500	66-56*	56-46*
0.500-5	56	46
5-30	60	50

Remark: "*" Decreasing linearly with logarithm of the frequency

Conducted Emission

Product Type : Robotic vacuum cleaner
 M/N : T10 Pro
 Operating Condition : Charging + BT Transmitting
 Test Specification : Line
 Comment : AC 120V/60Hz

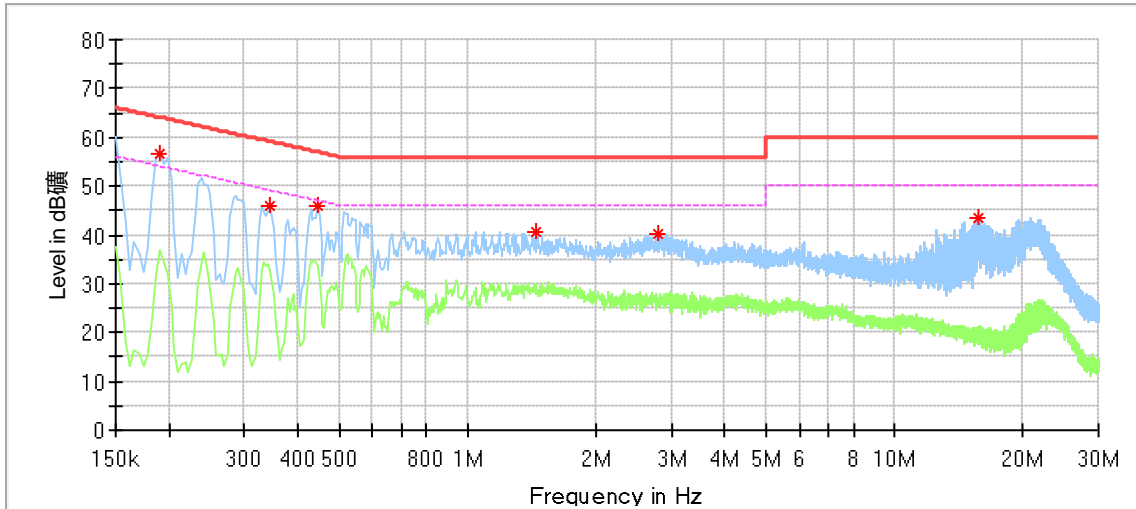

Critical Freqs

Frequency (MHz)	MaxPeak (dBµV)	Average (dBµV)	Limit (dBµV)	Margin (dB)	Line	Corr. (dB)
0.190000	56.49	---	64.04	7.54	L1	9.54
0.346000	46.15	---	59.06	12.91	L1	9.57
0.446000	46.15	---	56.95	10.80	L1	9.58
1.442000	40.46	---	56.00	15.54	L1	9.61
2.782000	40.37	---	56.00	15.63	L1	9.64
15.618000	43.42	---	60.00	16.58	L1	10.00

Conducted Emission

Product Type : Robotic vacuum cleaner
 M/N : T10 Pro
 Operating Condition : Charging + BT Transmitting
 Test Specification : Neutral
 Comment : AC 120V/60Hz

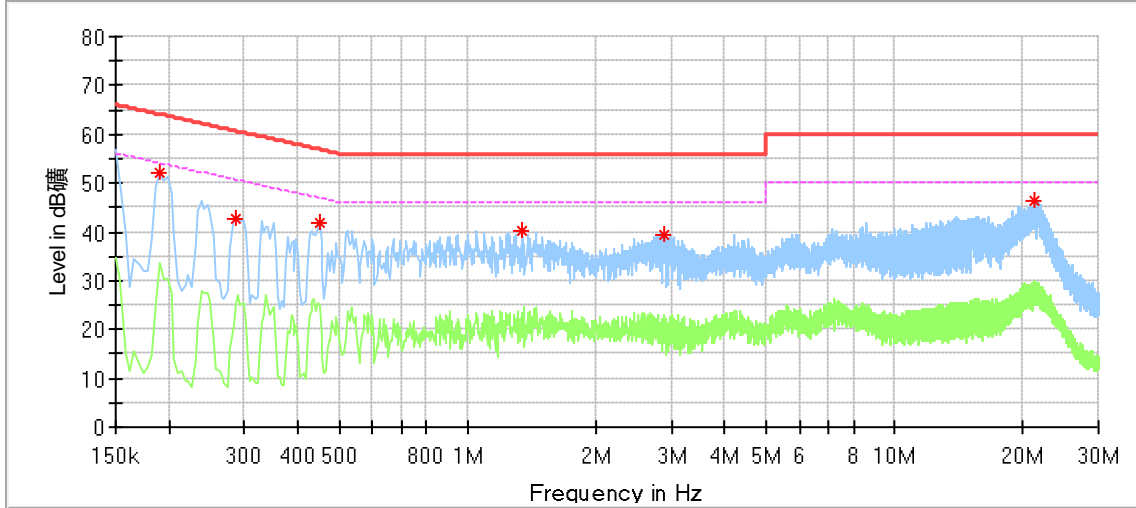

Critical Freqs

Frequency (MHz)	MaxPeak (dBµV)	Average (dBµV)	Limit (dBµV)	Margin (dB)	Line	Corr. (dB)
0.190000	51.99	---	64.04	12.04	N	9.57
0.286000	42.83	---	60.64	17.81	N	9.59
0.450000	41.74	---	56.88	15.14	N	9.61
1.346000	40.29	---	56.00	15.71	N	9.64
2.886000	39.36	---	56.00	16.64	N	9.68
21.190000	46.35	---	60.00	13.65	N	9.96

9.2 Conducted Peak Output Power & EIRP

Test Method

1. The RF output of EUT was connected to the spectrum analyzer by RF cable. The path loss was compensated to the results for each measurement.
2. Set to the maximum power setting and enable the EUT transmit continuously
3. Use the following test receiver settings:
Span = approximately 5 times the 20dB bandwidth, centered on a hopping channel
RBW > the 20dB bandwidth of the emission being measured, VBW ≥ RBW,
Sweep = auto, Detector function = peak, Trace = max hold
4. Allow the trace to stabilize. Use the marker-to-peak function to set the marker to the peak of the emission. The indicated level is the peak output power and record the results in the test report.
5. Repeat above procedures until all frequencies measured were complete.

Limits

According to §15.247 (b) (1) & RSS-247 5.4(b), conducted peak output power limit as below:

Frequency Range MHz	Limit W	Limit dBm
2400-2483.5	≤1	≤30

According to & RSS-247 5.4(b), EIRP limit as below:

Frequency Range MHz	Limit W	Limit dBm
2400-2483.5	≤4	≤36

Test Results

Mode	Frequency (MHz)	Gain (dBi)	Measured Power (dBm)	EIRP (dBm)	Conducted output power limit (dBm)	EIRP Limit (dBm)	Verdict
GFSK	2402	4.5	2.30	6.80	≤30	≤36	Pass
	2441	4.5	2.29	6.79	≤30	≤36	Pass
	2480	4.5	2.07	6.57	≤30	≤36	Pass
Pi/4DQPSK	2402	4.5	4.55	9.05	≤30	≤36	Pass
	2441	4.5	4.62	9.12	≤30	≤36	Pass
	2480	4.5	4.37	8.87	≤30	≤36	Pass
8DPSK	2402	4.5	5.06	9.56	≤30	≤36	Pass
	2441	4.5	5.11	9.61	≤30	≤36	Pass
	2480	4.5	4.86	9.36	≤30	≤36	Pass

Note1: E.I.R.P = Measured Power + Antenna Gain

Test Graphs

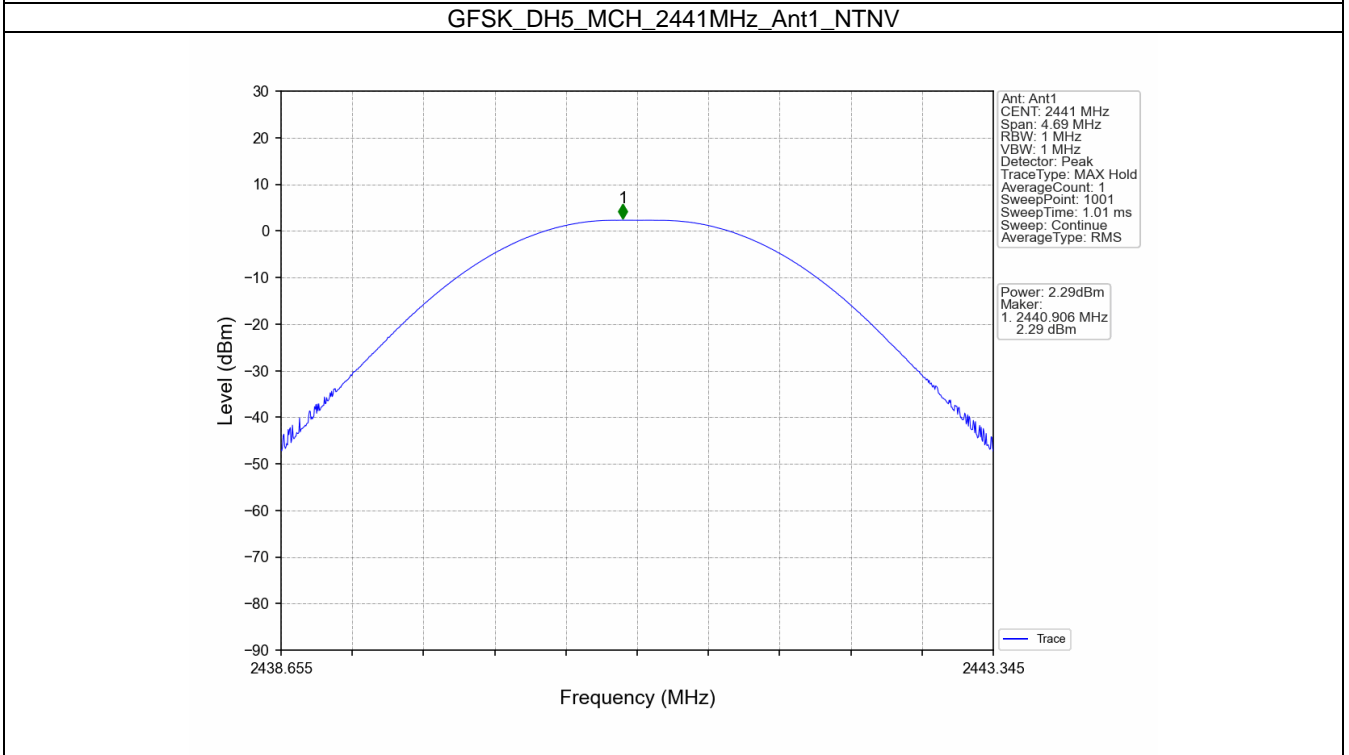
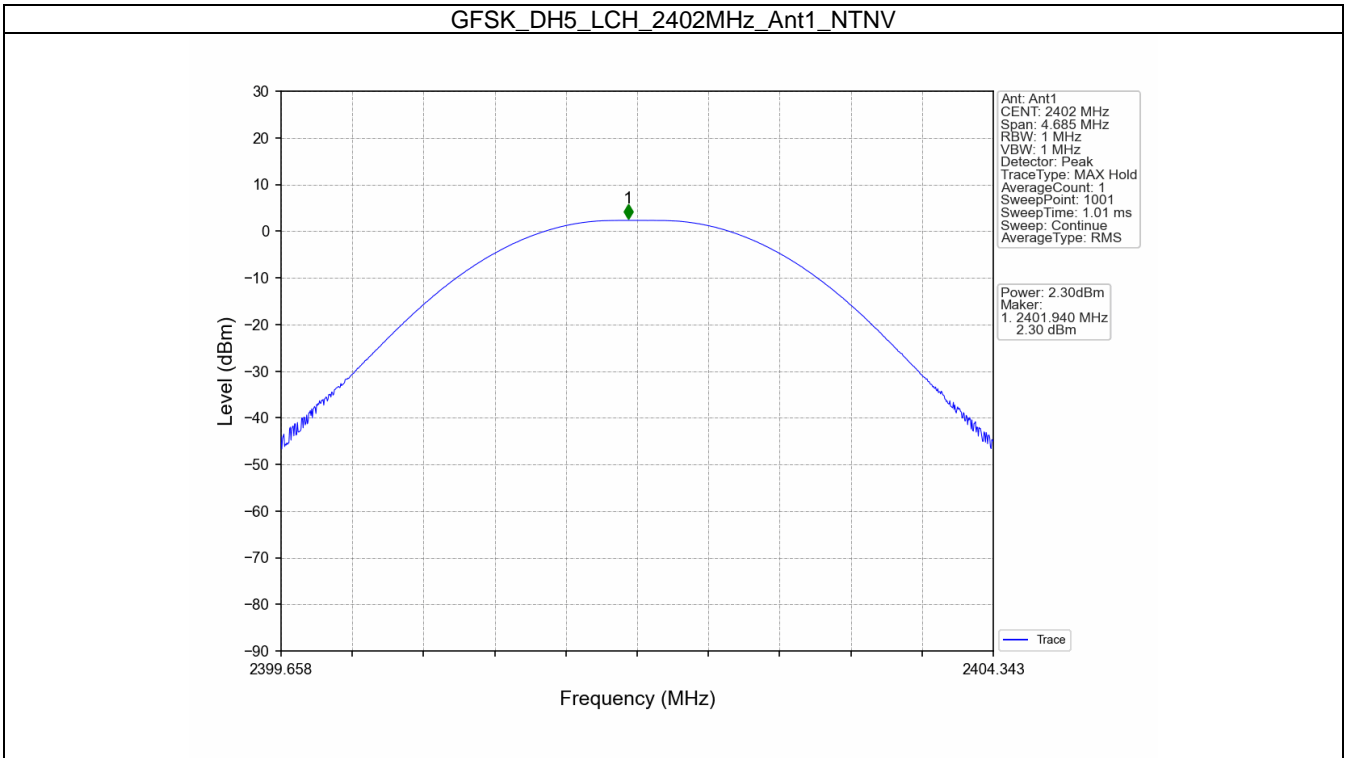

GFSK_DH5_HCH_2480MHz_Ant1_NTNV

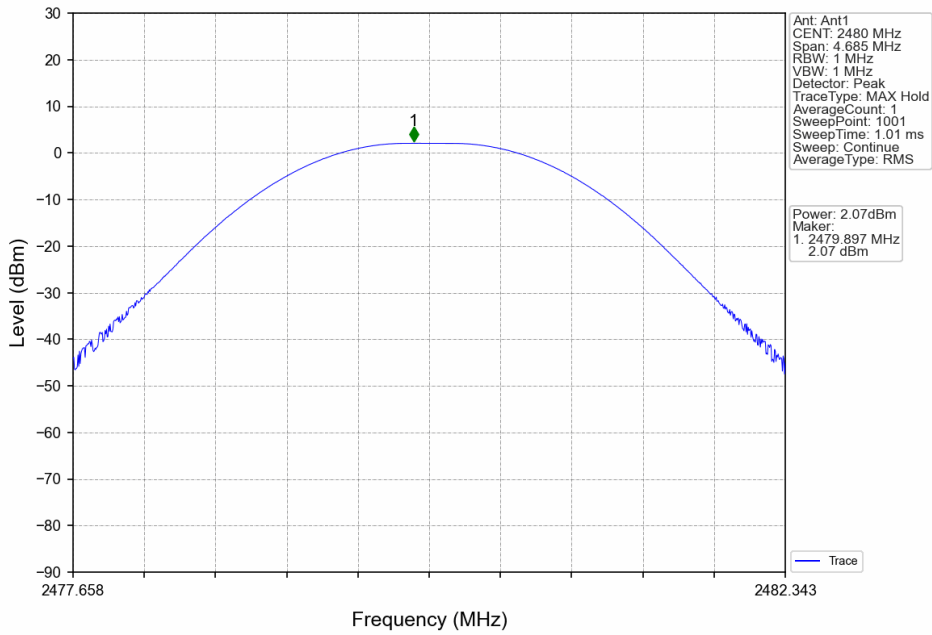

Pi/4DQPSK_2DH5_LCH_2402MHz_Ant1_NTNV

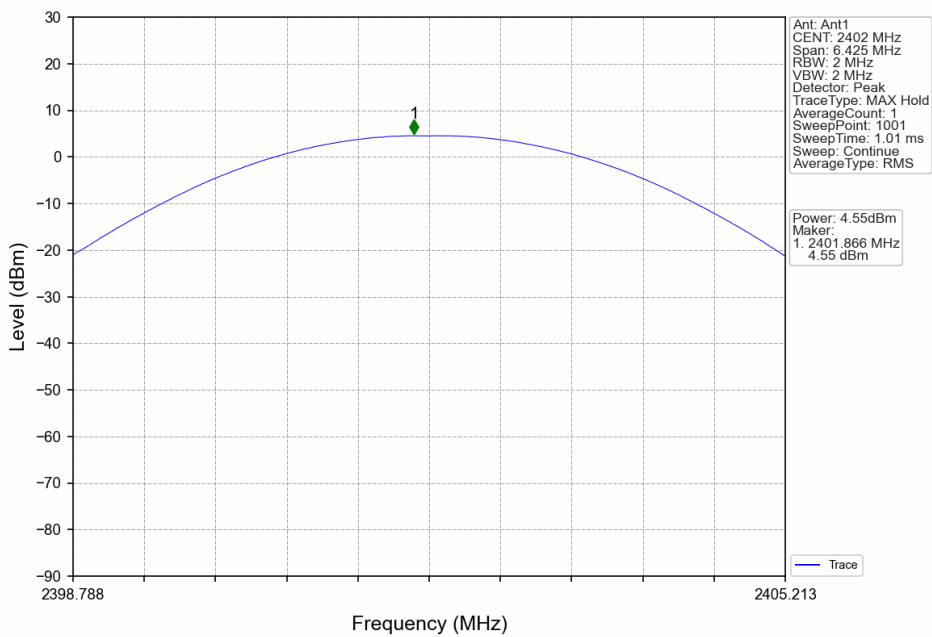

Pi/4DQPSK_2DH5_MCH_2441MHz_Ant1_NTNV

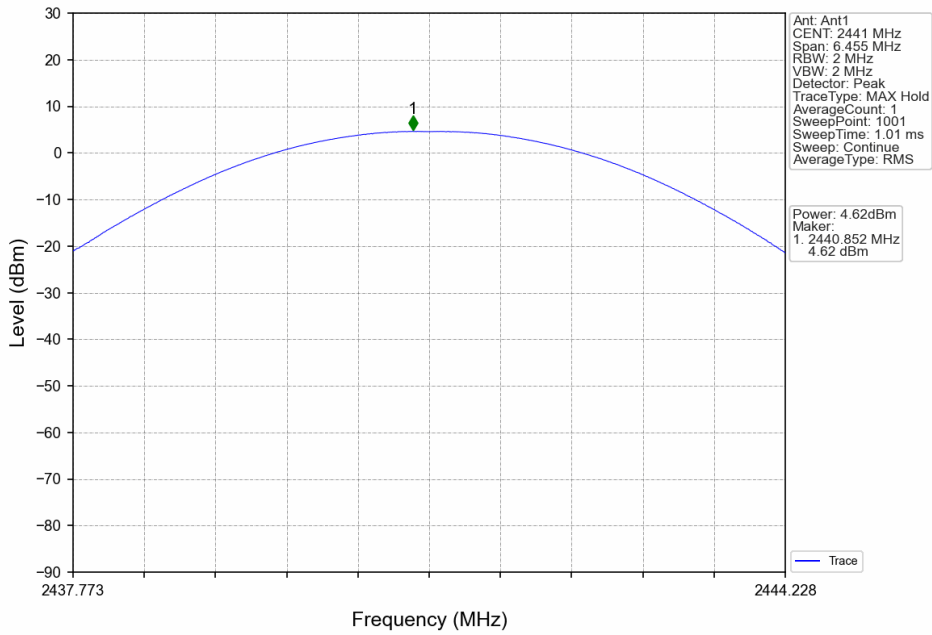

Pi/4DQPSK_2DH5_HCH_2480MHz_Ant1_NTNV

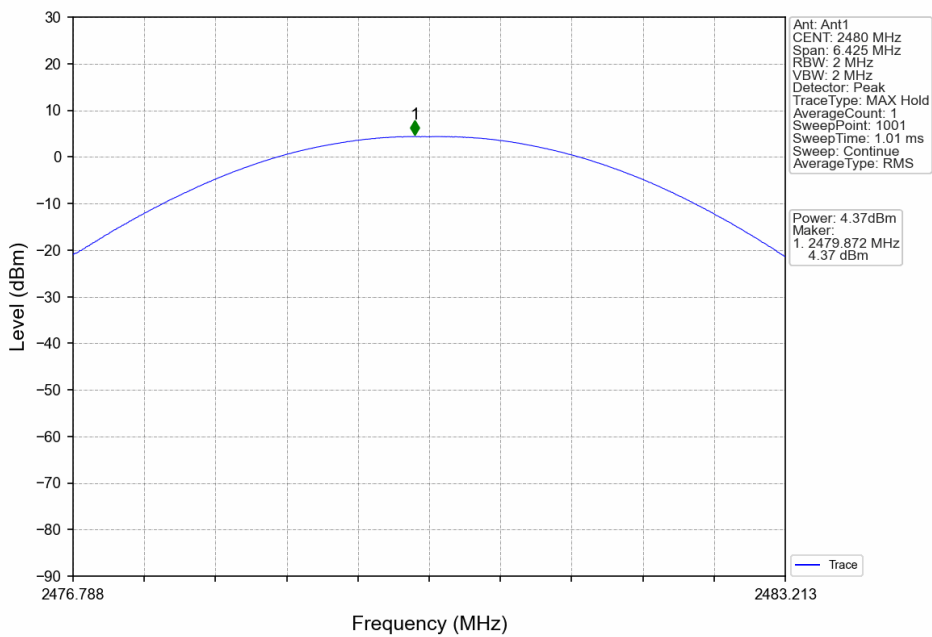

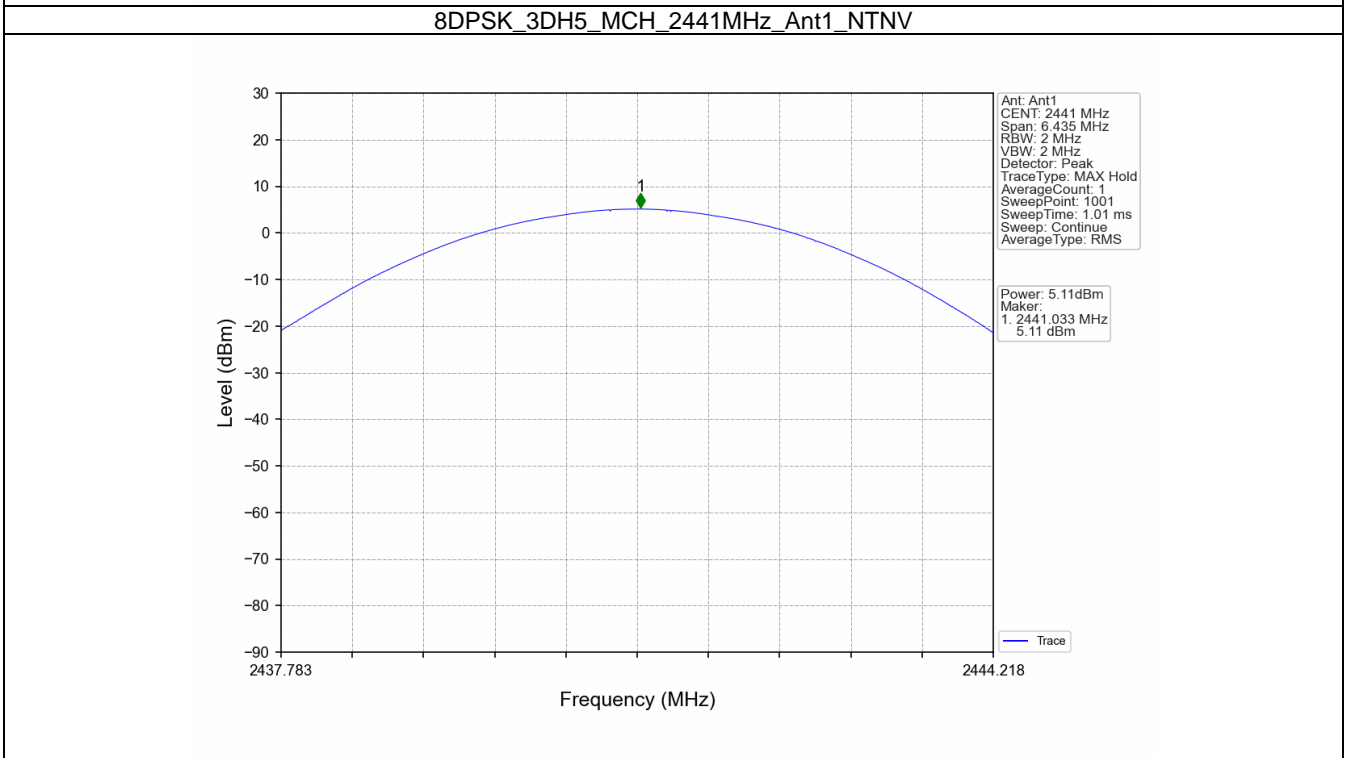
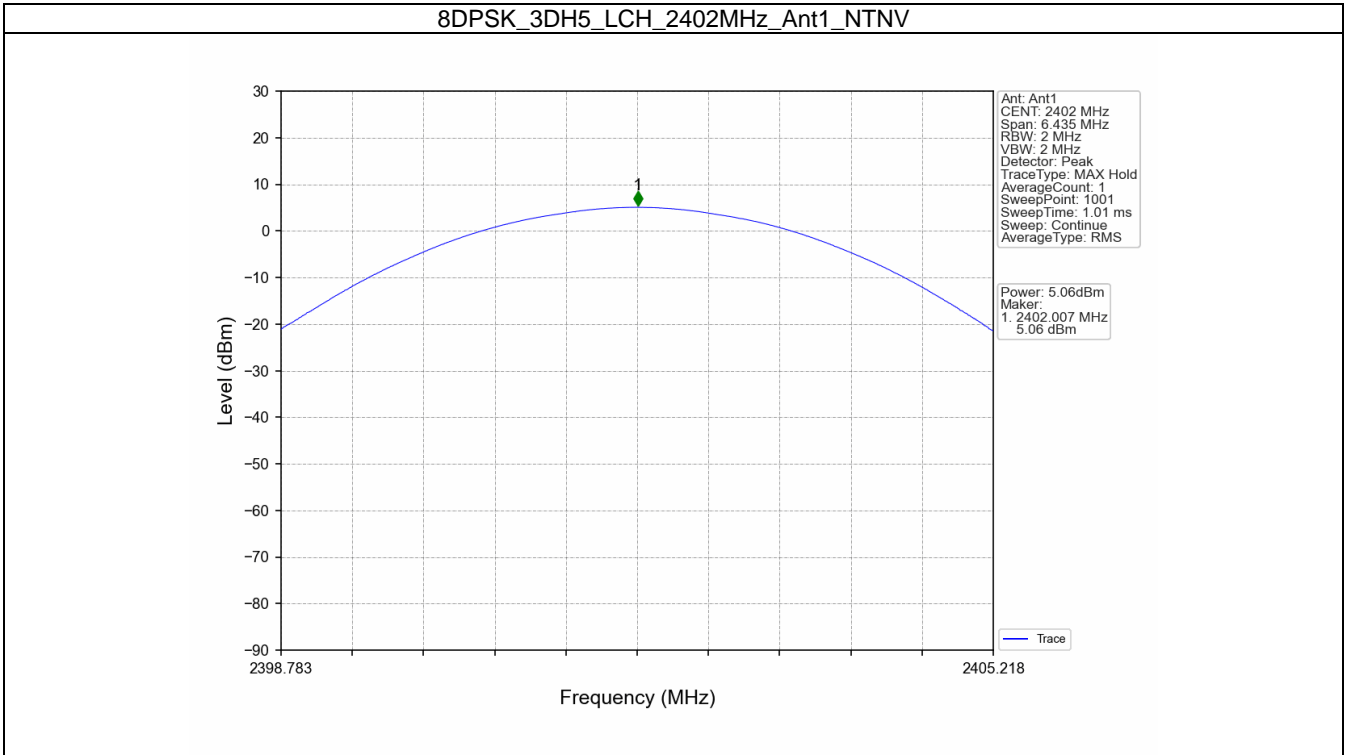

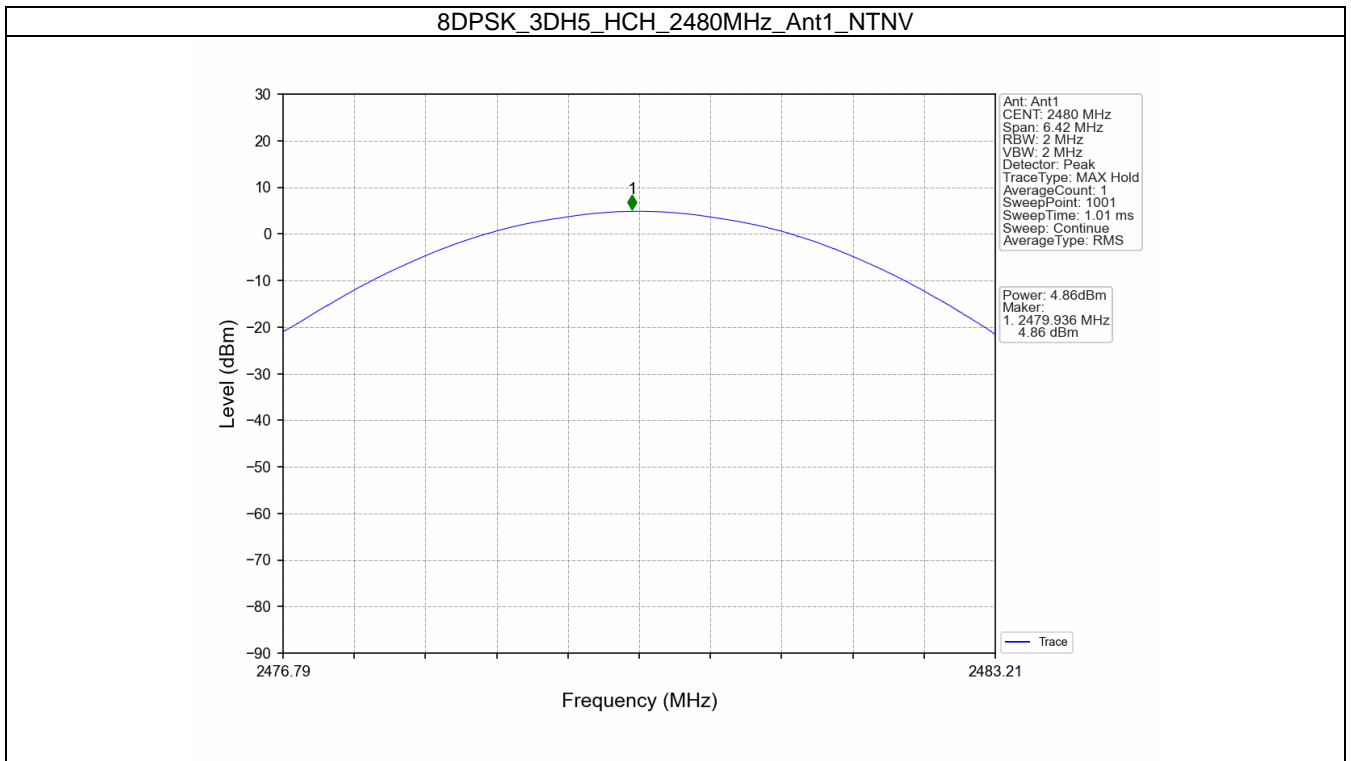

9.3 20 dB Bandwidth and 99% Occupied Bandwidth

Test Method

1. The RF output of EUT was connected to the spectrum analyzer by RF cable. The path loss was compensated to the results for each measurement.
2. Set to the maximum power setting and enable the EUT transmit continuously.
3. Use the following test receiver settings:
Span = approximately 2 to 3 times the 20 dB bandwidth, centered on a hopping channel
RBW \geq 1% to 5% of the 20 dB bandwidth/99% OBW, VBW \geq 3RBW,
Sweep = auto, Detector function = peak, Trace = max hold
4. Allow the trace to stabilize. Use the marker-to-peak function to set the marker to the peak of the emission. Measure the frequency difference of two frequencies that were attenuated 20 dB/99% OBW from the reference level. Record the frequency difference as the emission bandwidth. Record the results.
5. Repeat above procedures until all frequencies measured were complete.

Limit

Limit [kHz]

N/A

Test Results

20dB bandwidth

Mode	Frequency (MHz)	Packet Type	20dB Bandwidth (MHz)		Verdict
			Result	Limit	
GFSK	2402	DH5	0.937	/	Pass
	2441	DH5	0.938	/	Pass
	2480	DH5	0.937	/	Pass
Pi/4DQPSK	2402	2DH5	1.285	/	Pass
	2441	2DH5	1.291	/	Pass
	2480	2DH5	1.285	/	Pass
8DPSK	2402	3DH5	1.287	/	Pass
	2441	3DH5	1.287	/	Pass
	2480	3DH5	1.284	/	Pass

99% Occupied Bandwidth

Mode	Frequency (MHz)	Packet Type	99% Occupied Bandwidth (MHz)		Verdict
			Result	Limit	
GFSK	2402	DH5	0.854	/	Pass
	2441	DH5	0.852	/	Pass
	2480	DH5	0.852	/	Pass
Pi/4DQPSK	2402	2DH5	1.183	/	Pass
	2441	2DH5	1.184	/	Pass
	2480	2DH5	1.184	/	Pass
8DPSK	2402	3DH5	1.169	/	Pass
	2441	3DH5	1.168	/	Pass
	2480	3DH5	1.167	/	Pass

Test Graphs

20dB bandwidth

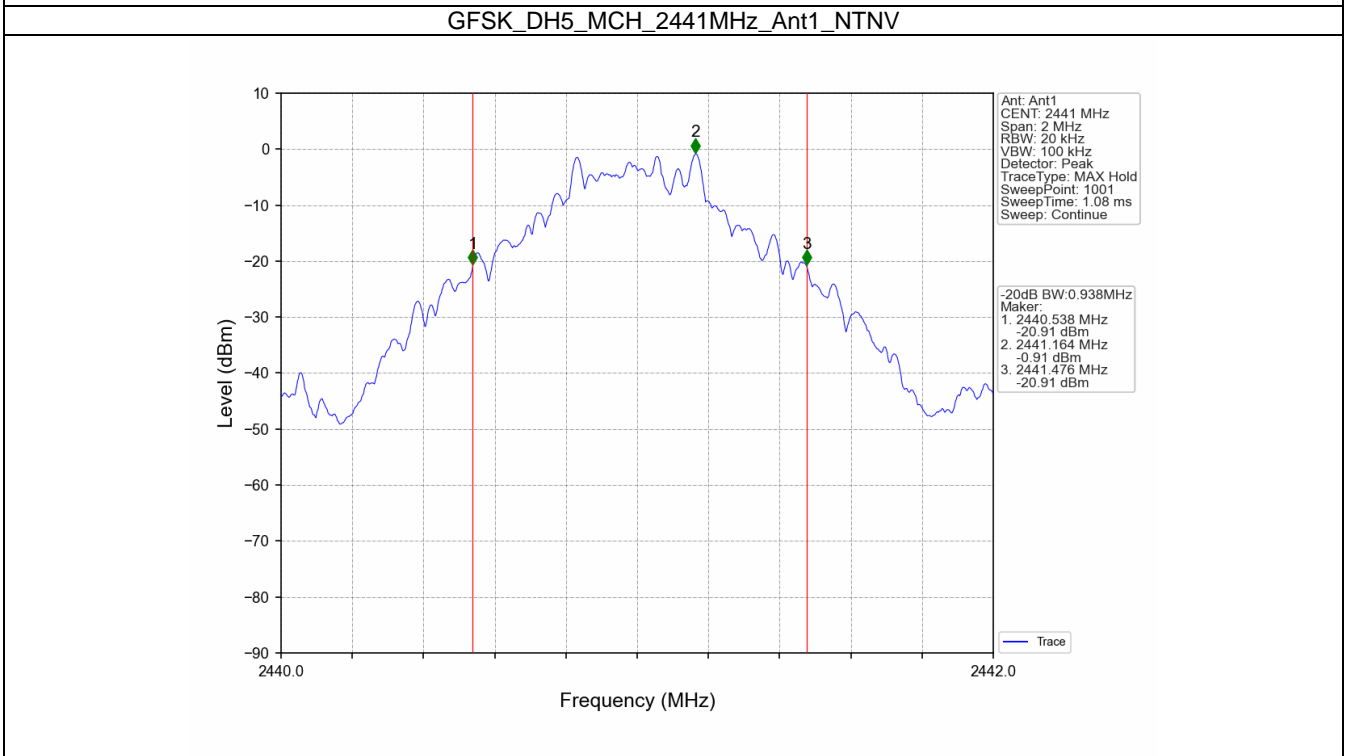
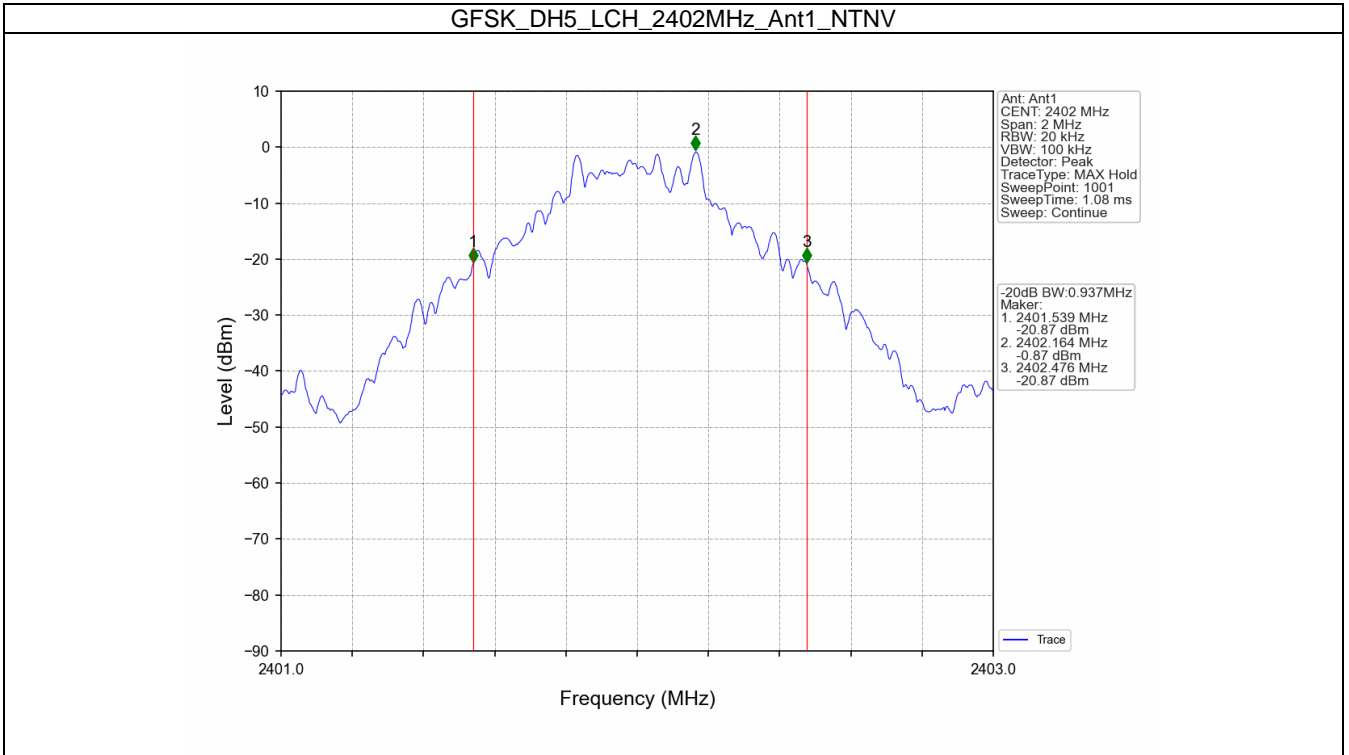

GFSK_DH5_HCH_2480MHz_Ant1_NTNV

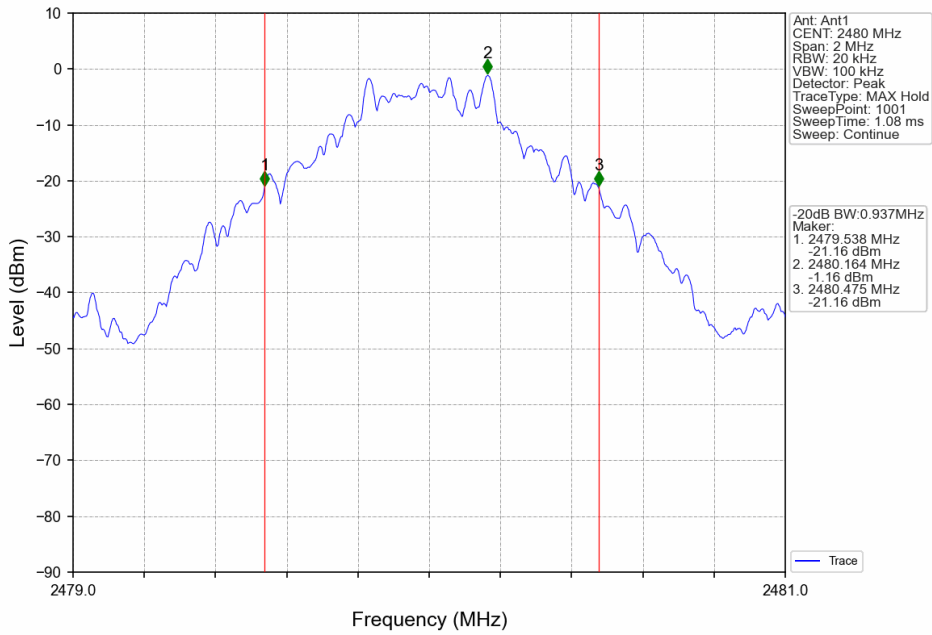

Pi/4DQPSK_2DH5_LCH_2402MHz_Ant1_NTNV

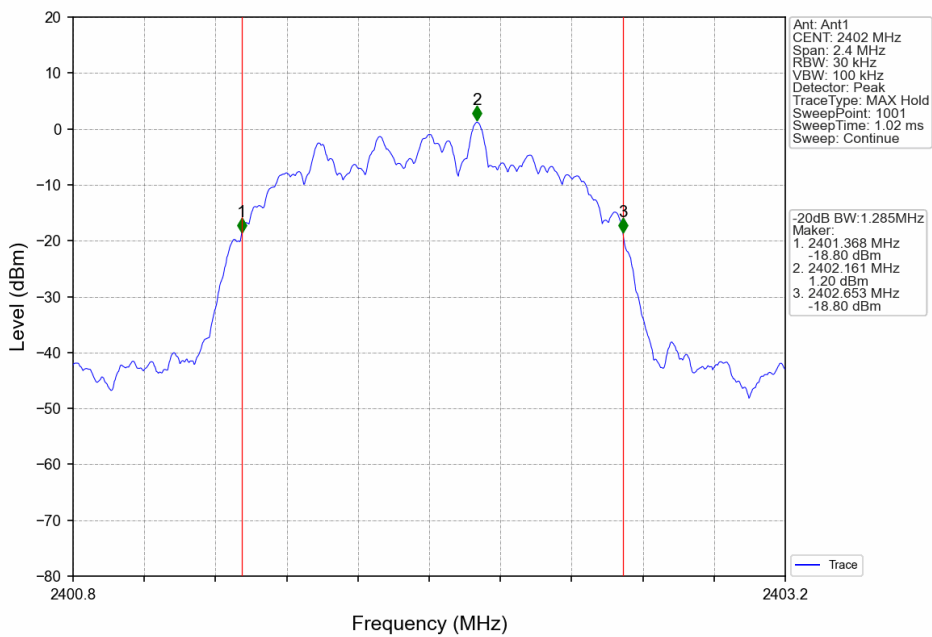

Pi/4DQPSK_2DH5_MCH_2441MHz_Ant1_NTNV

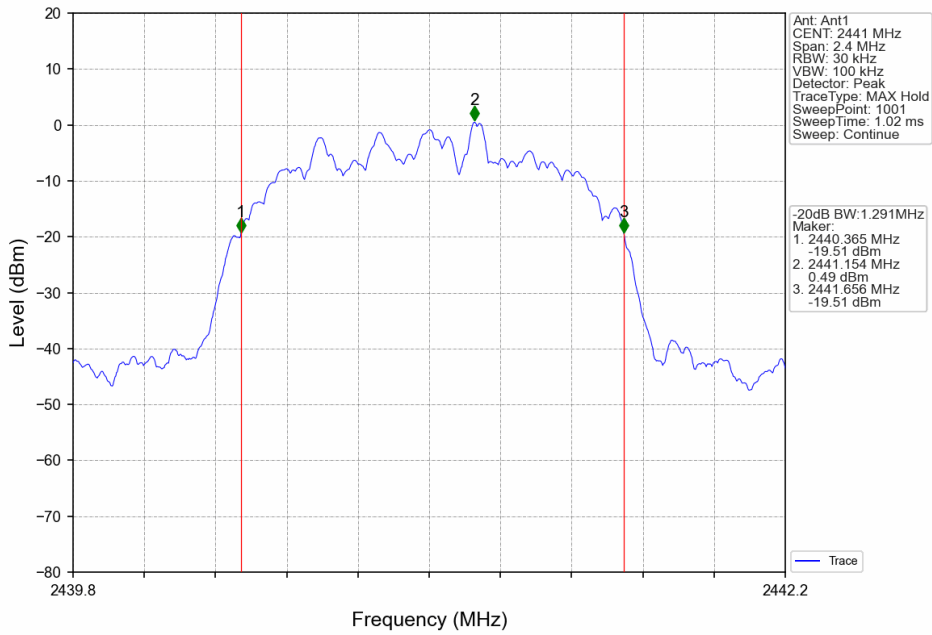

Pi/4DQPSK_2DH5_HCH_2480MHz_Ant1_NTNV

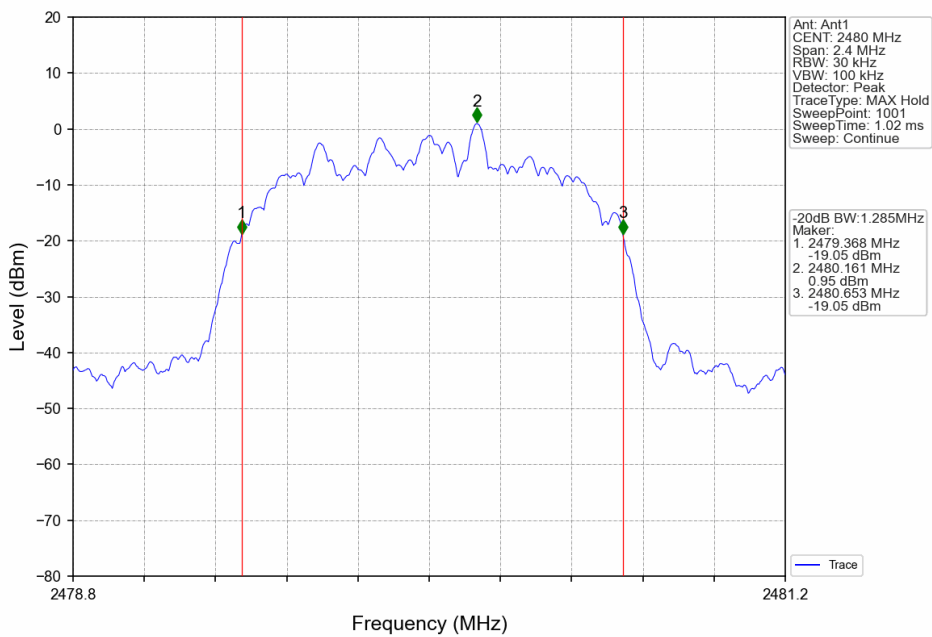

8DPSK_3DH5_LCH_2402MHz_Ant1_NTNV

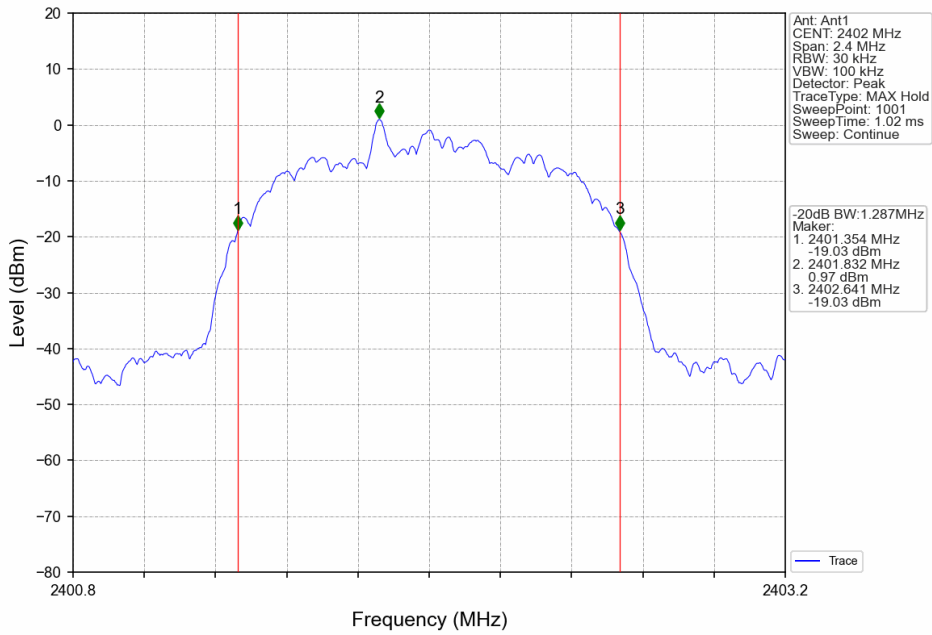

8DPSK_3DH5_MCH_2441MHz_Ant1_NTNV

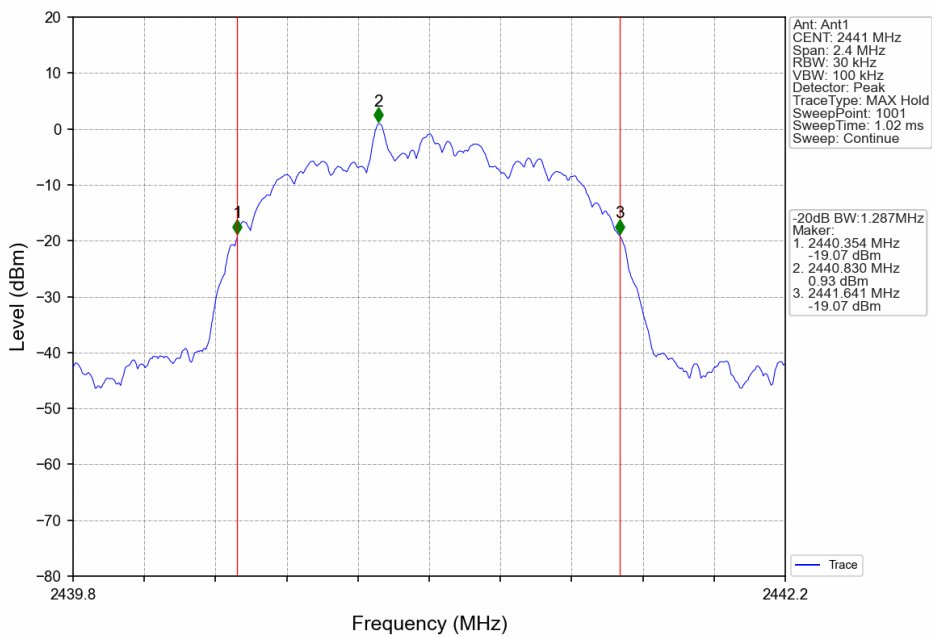

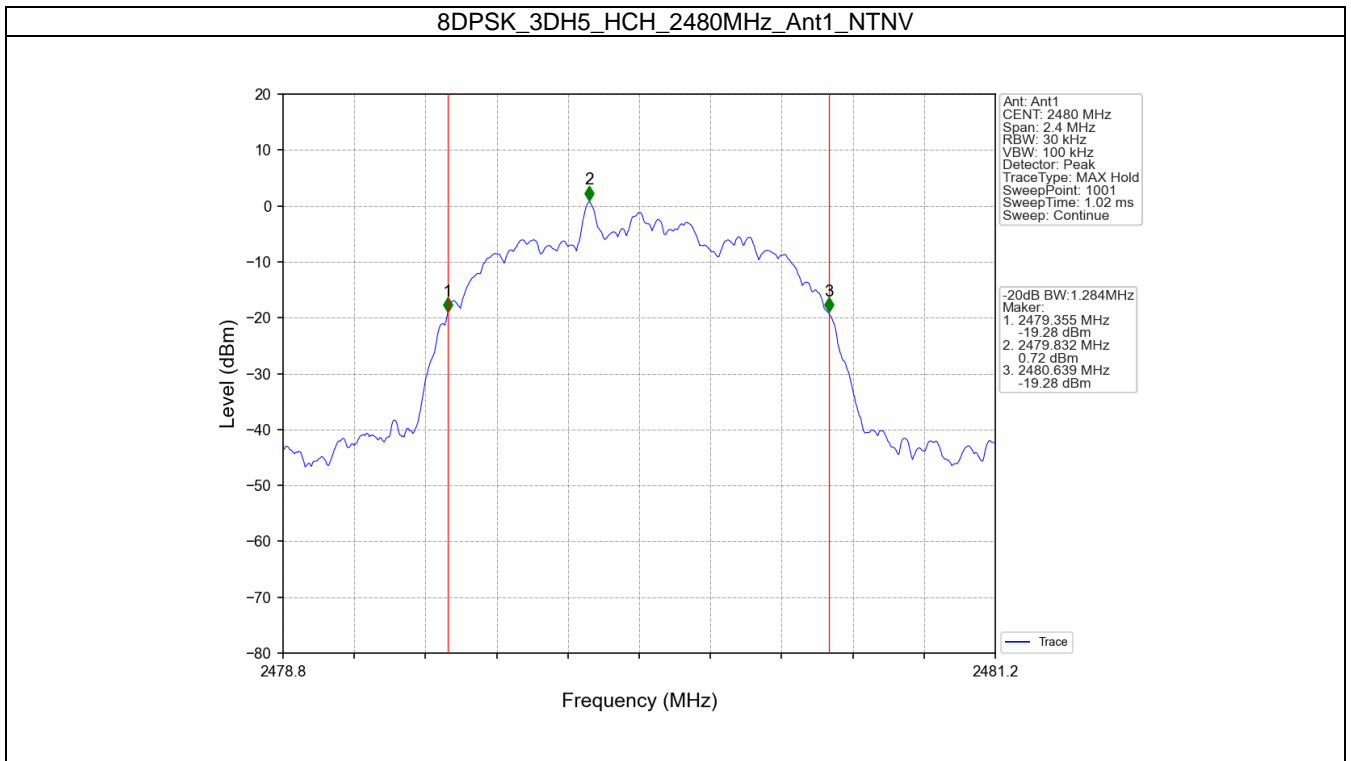

99% Occupied Bandwidth

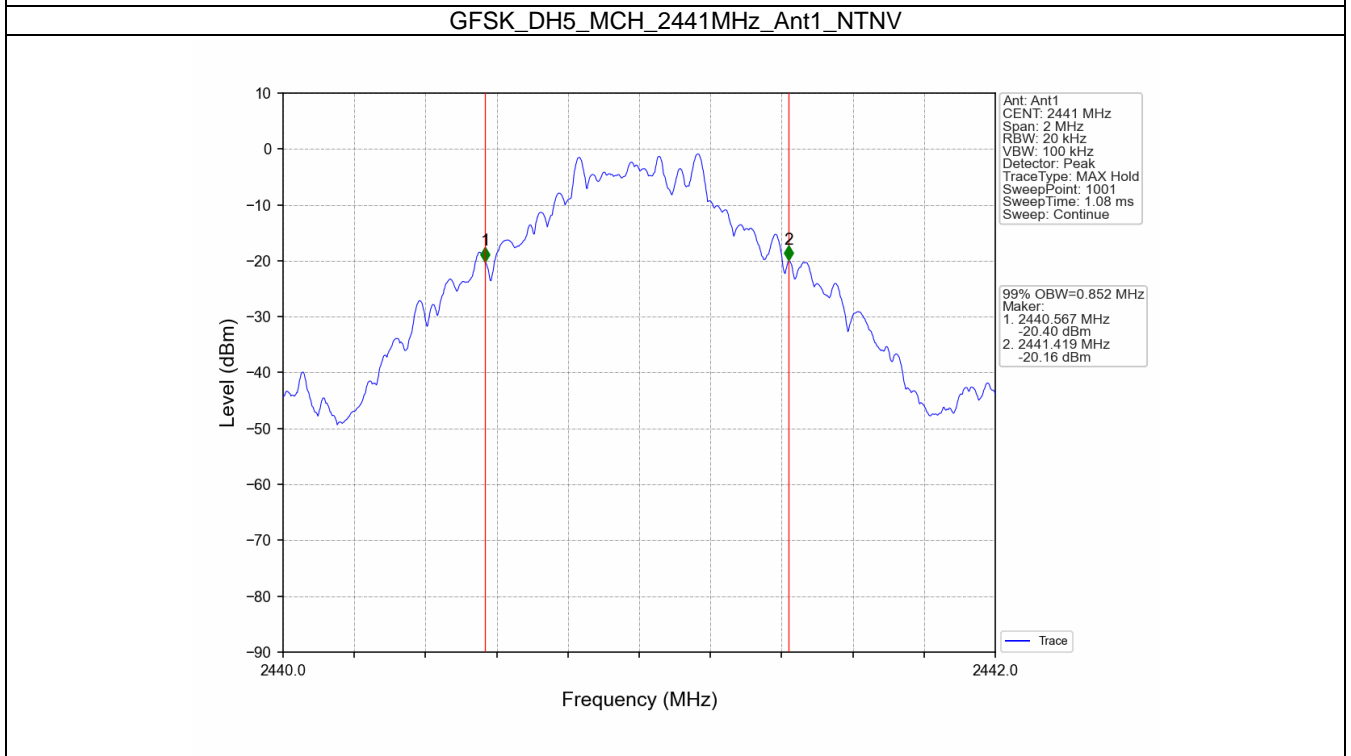
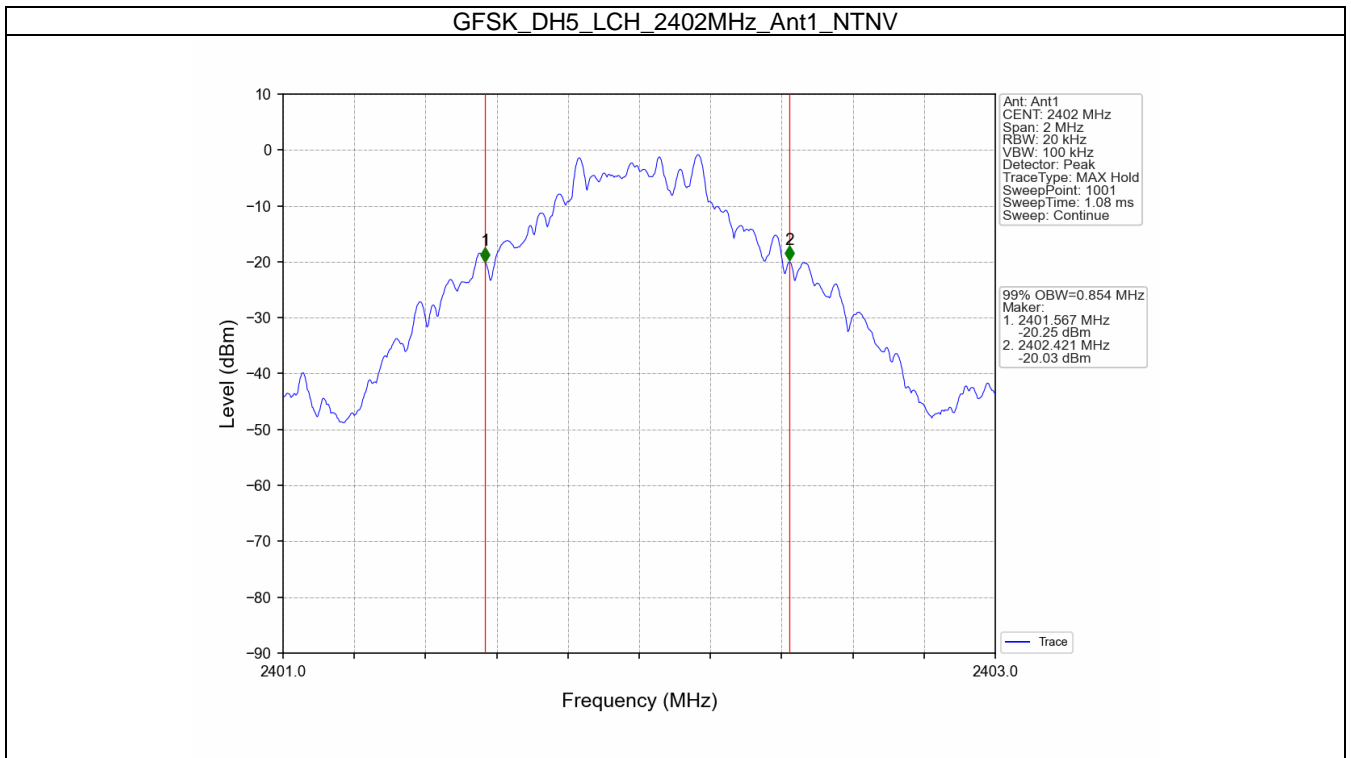

GFSK_DH5_HCH_2480MHz_Ant1_NTNV

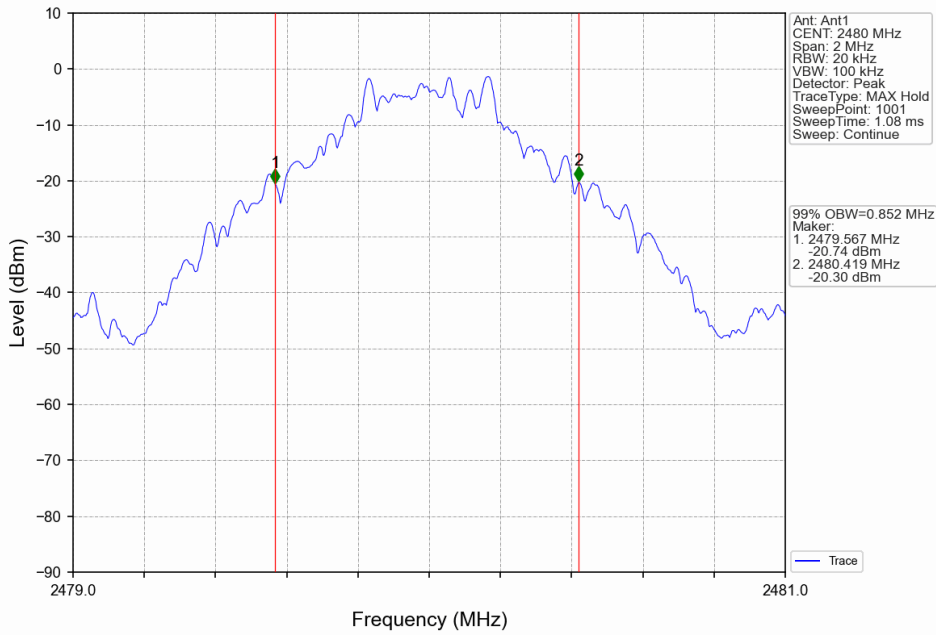

Pi/4DQPSK_2DH5_LCH_2402MHz_Ant1_NTNV

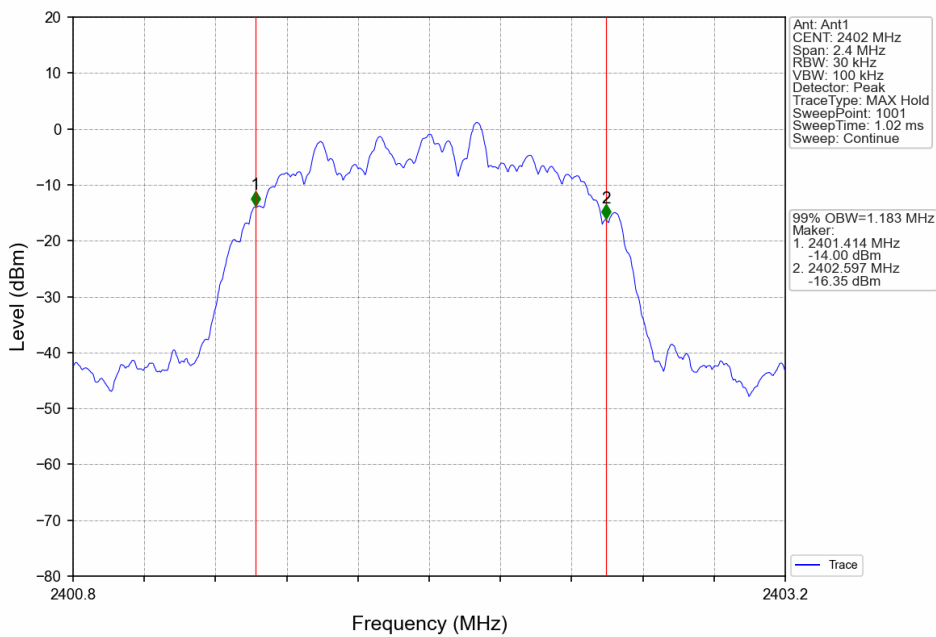

Pi/4DQPSK_2DH5_MCH_2441MHz_Ant1_NTNV

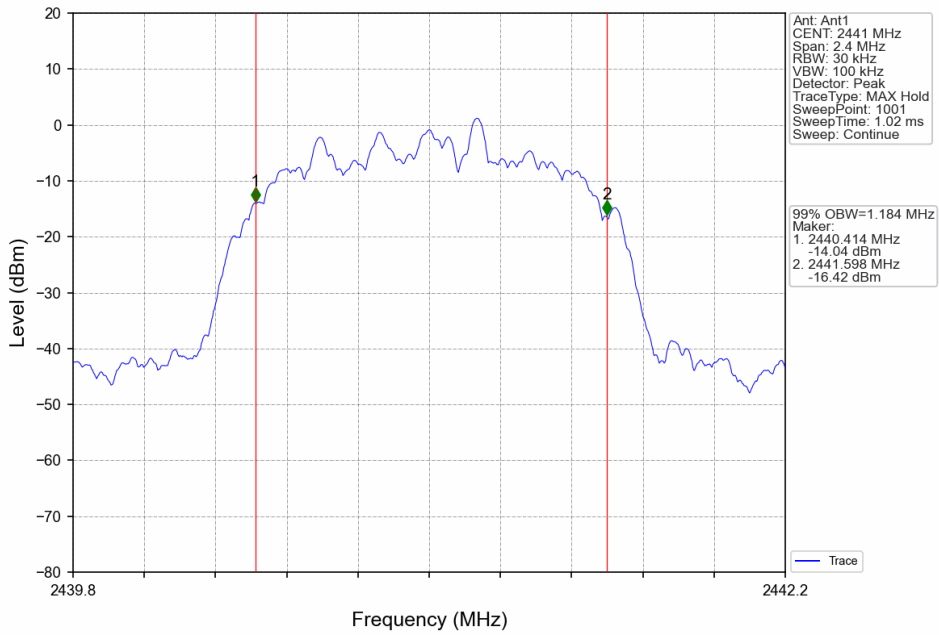

Pi/4DQPSK_2DH5_HCH_2480MHz_Ant1_NTNV

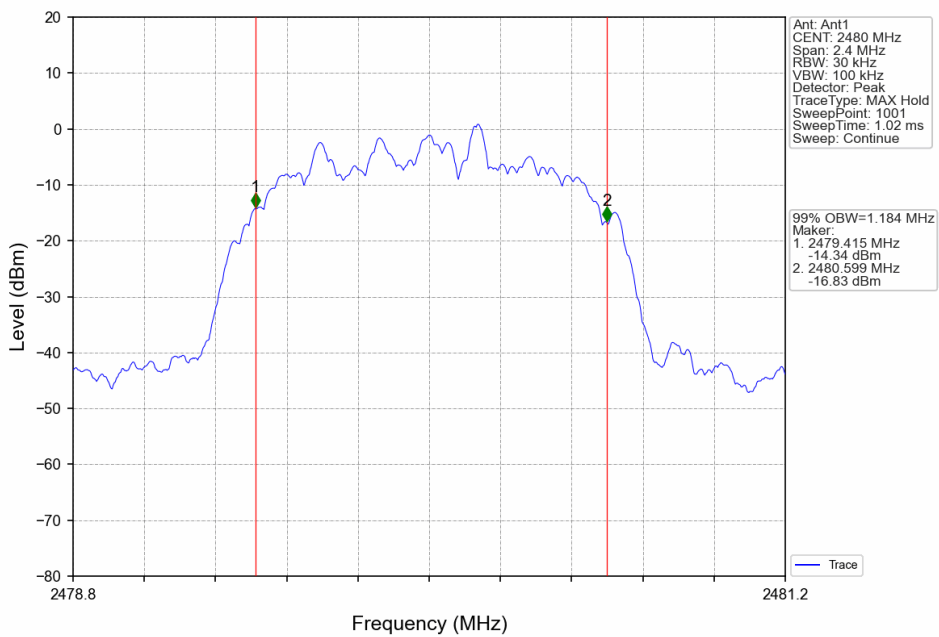

8DPSK_3DH5_LCH_2402MHz_Ant1_NTNV

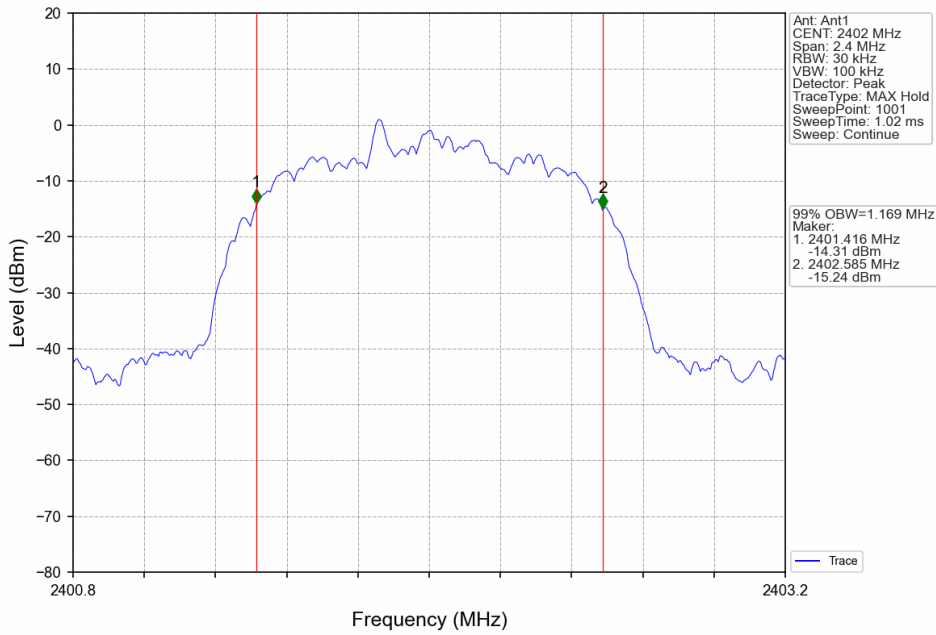

8DPSK_3DH5_MCH_2441MHz_Ant1_NTNV

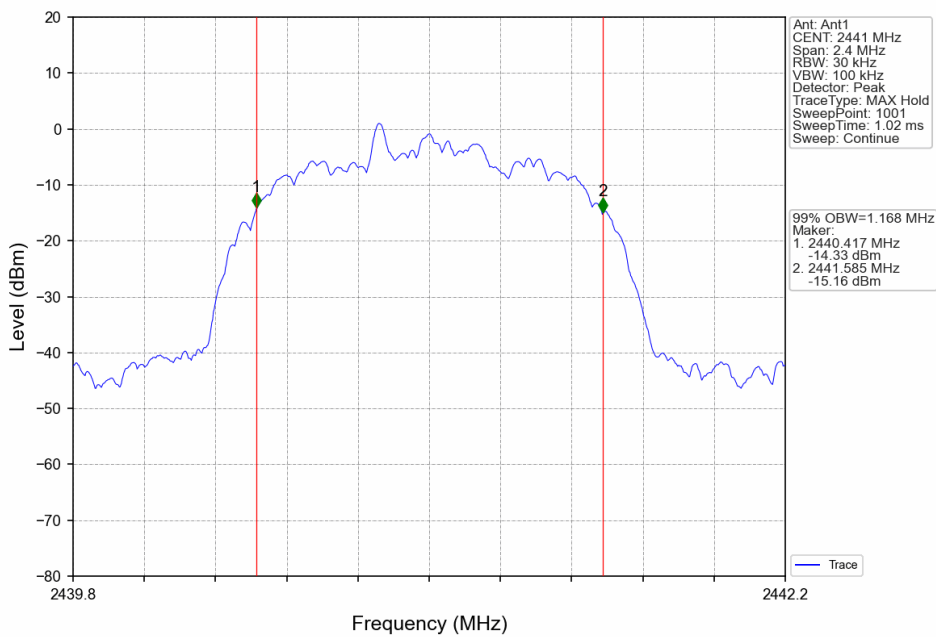

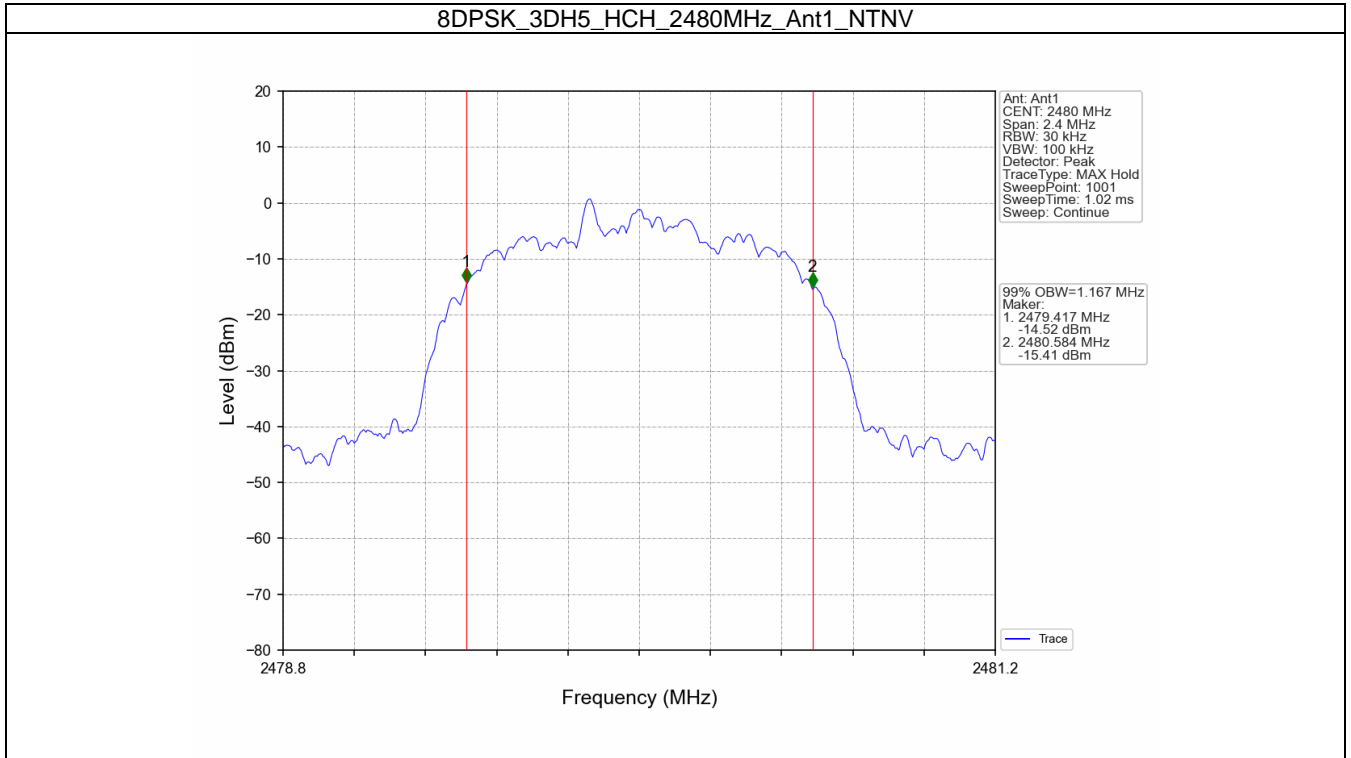

9.4 Carrier Frequency Separation

Test Method

1. The RF output of EUT was connected to the spectrum analyzer by RF cable. The path loss was compensated to the results for each measurement.
2. Set to the maximum power setting and enable the EUT transmit to hopping mode.
3. Use the following spectrum analyzer settings:
Span = wide enough to capture the peaks of two adjacent channels, RBW: Start with the RBW set to approximately 30% of the channel spacing; adjust as necessary to best identify the center of each individual channel. VBW \geq RBW, Sweep = auto, Detector function = peak.
4. By using the Max-Hold function record the separation of two adjacent channels.
5. Measure the frequency difference of these two adjacent channels by spectrum analyzer marker function. Record the results.
6. Repeat above procedures until all frequencies measured were complete.

Limits

Limit
kHz

$\geq 25\text{kHz}$ or $2/3$ of the 20 dB bandwidth which is greater

Test Results

Mode	Frequency (MHz)	Packet Type	Channel Separation (MHz)	20dB Bandwidth (MHz)	Limit (MHz)	Verdict
GFSK	HOPP	DH5	1.000	0.938	≥ 0.625	Pass
Pi/4DQPSK	HOPP	2DH5	1.001	1.291	≥ 0.861	Pass
8DPSK	HOPP	3DH5	1.001	1.287	≥ 0.858	Pass

Test Graphs

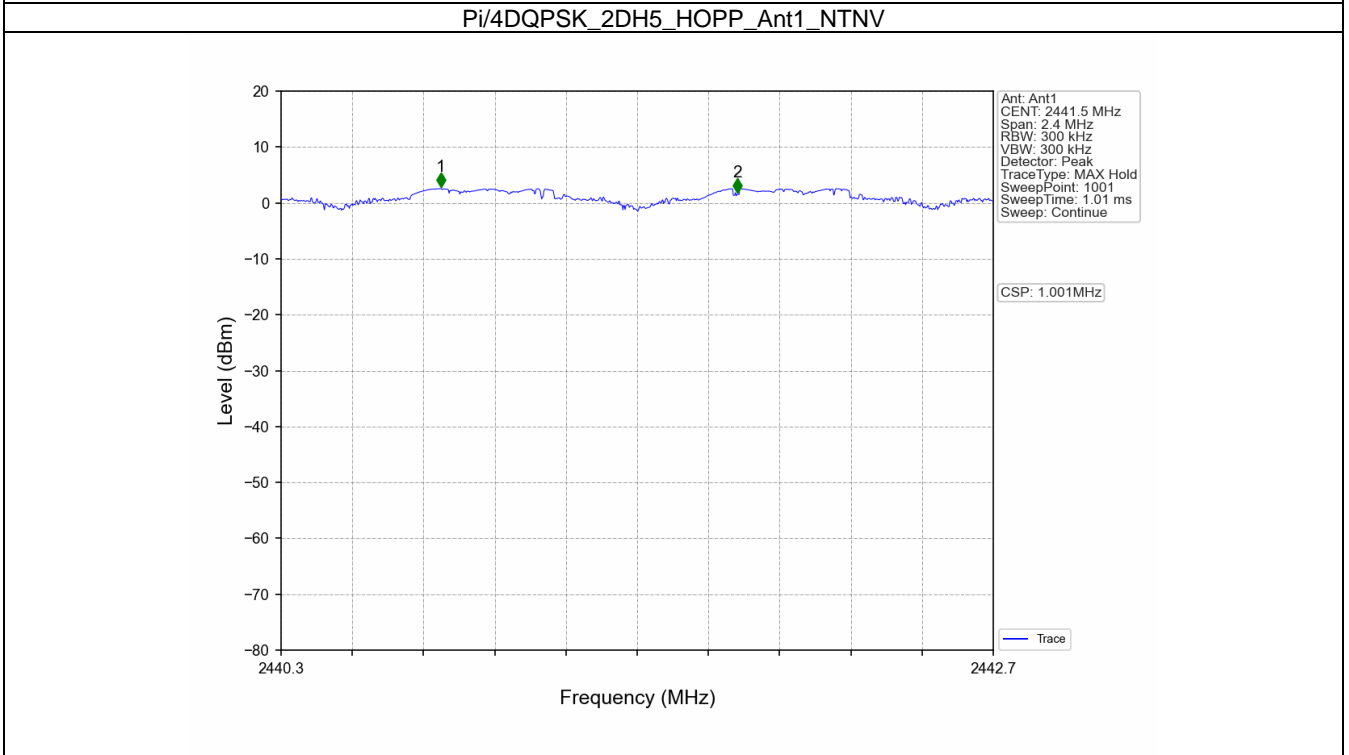
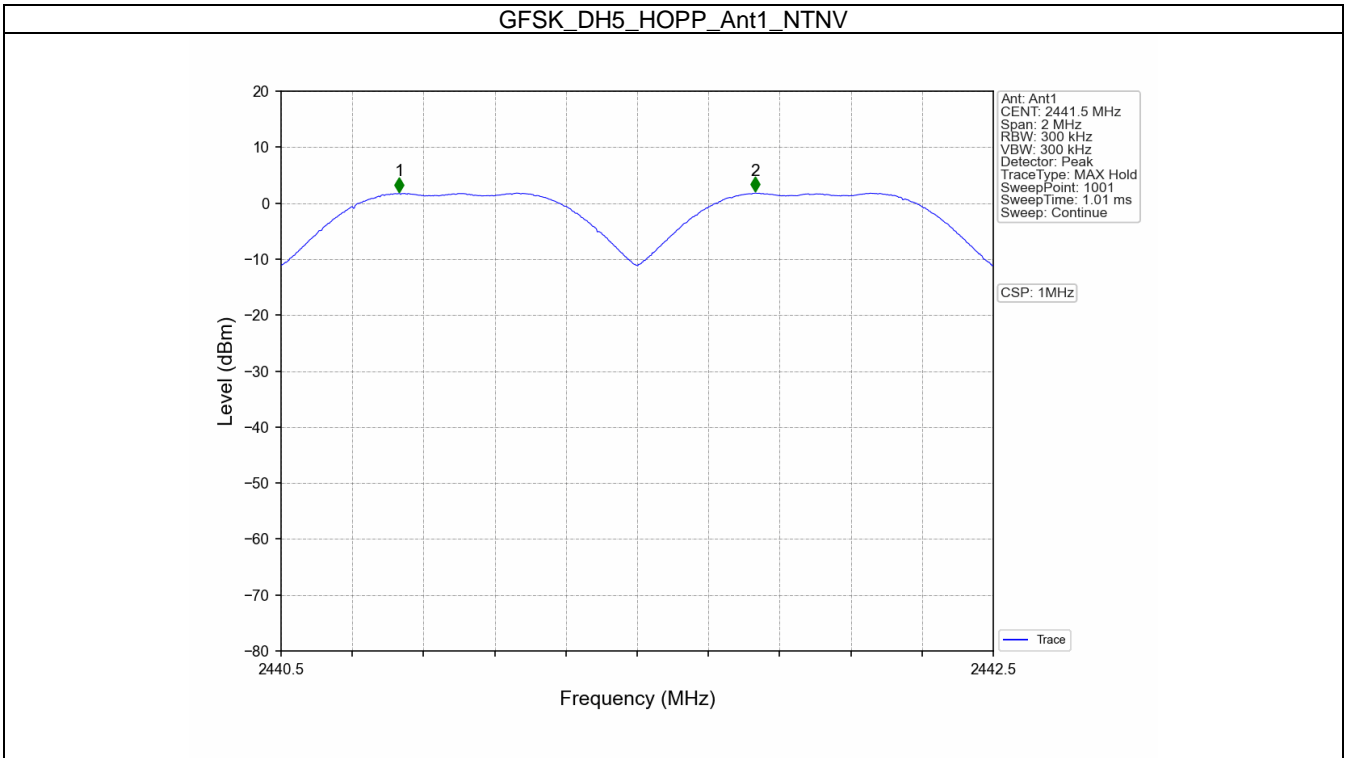

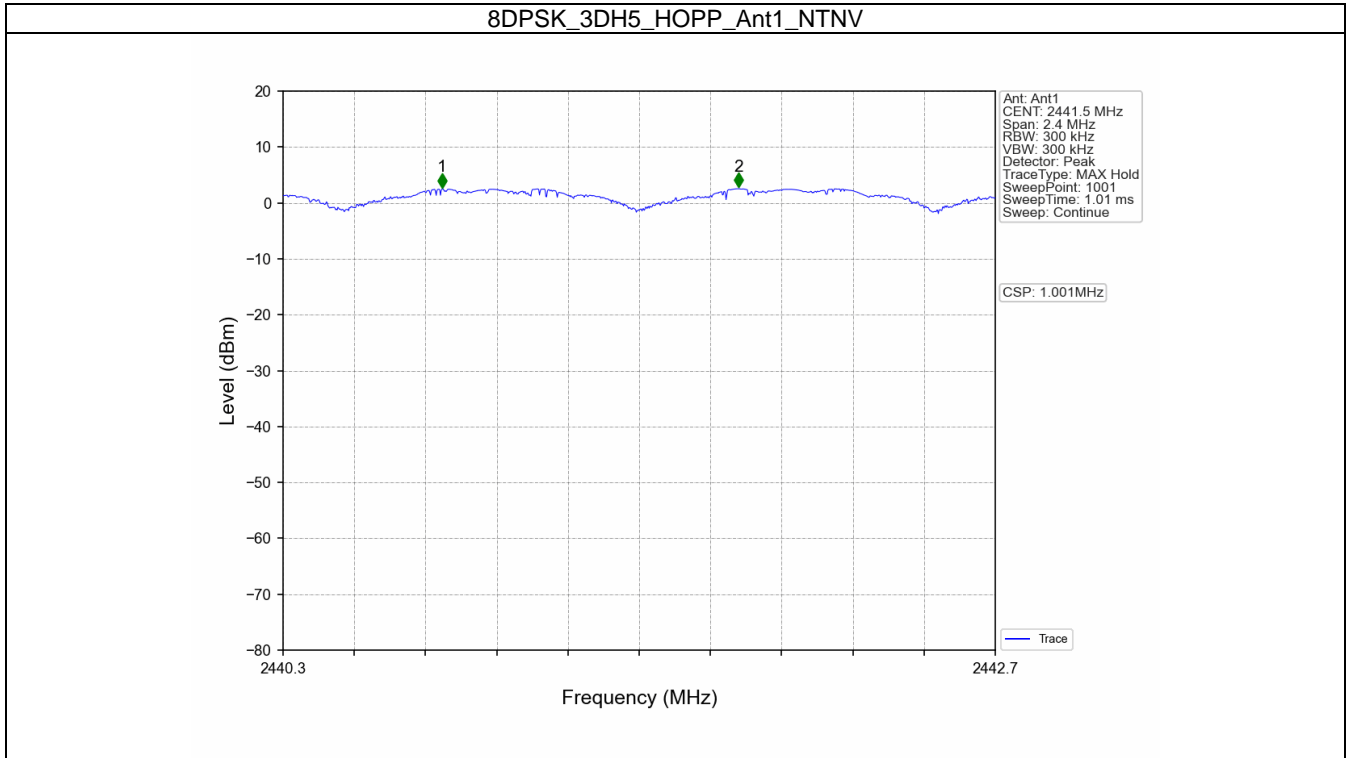

9.5 Number of Hopping Frequencies

Test Method

1. The RF output of EUT was connected to the spectrum analyzer by RF cable. The path loss was compensated to the results for each measurement.
2. Set to the maximum power setting and enable the EUT transmit to hopping mode.
3. Use the following spectrum analyzer settings:
Span = the frequency band of operation, RBW: To identify clearly the individual channels, set the RBW to less than 30% of the channel spacing or the 20 dB bandwidth, whichever is smaller, VBW ≥ RBW, Sweep = auto, Detector function = peak, Trace=Max hold.
4. Allow the trace to stabilize. It may prove necessary to break the span up to sections, in order to clearly show all of the hopping frequencies. The limit is specified in one of the subparagraphs of this Section. Submit this plot(s).

Limit

Limit
number

≥ 15

Test Results

Mode	Frequency (MHz)	Packet Type	Num of Hopping Frequencies		Verdict
			Result	Limit	
GFSK	HOPP	DH5	79	≥15	Pass
Pi/4DQPSK	HOPP	2DH5	79	≥15	Pass
8DPSK	HOPP	3DH5	79	≥15	Pass

Test Graphs

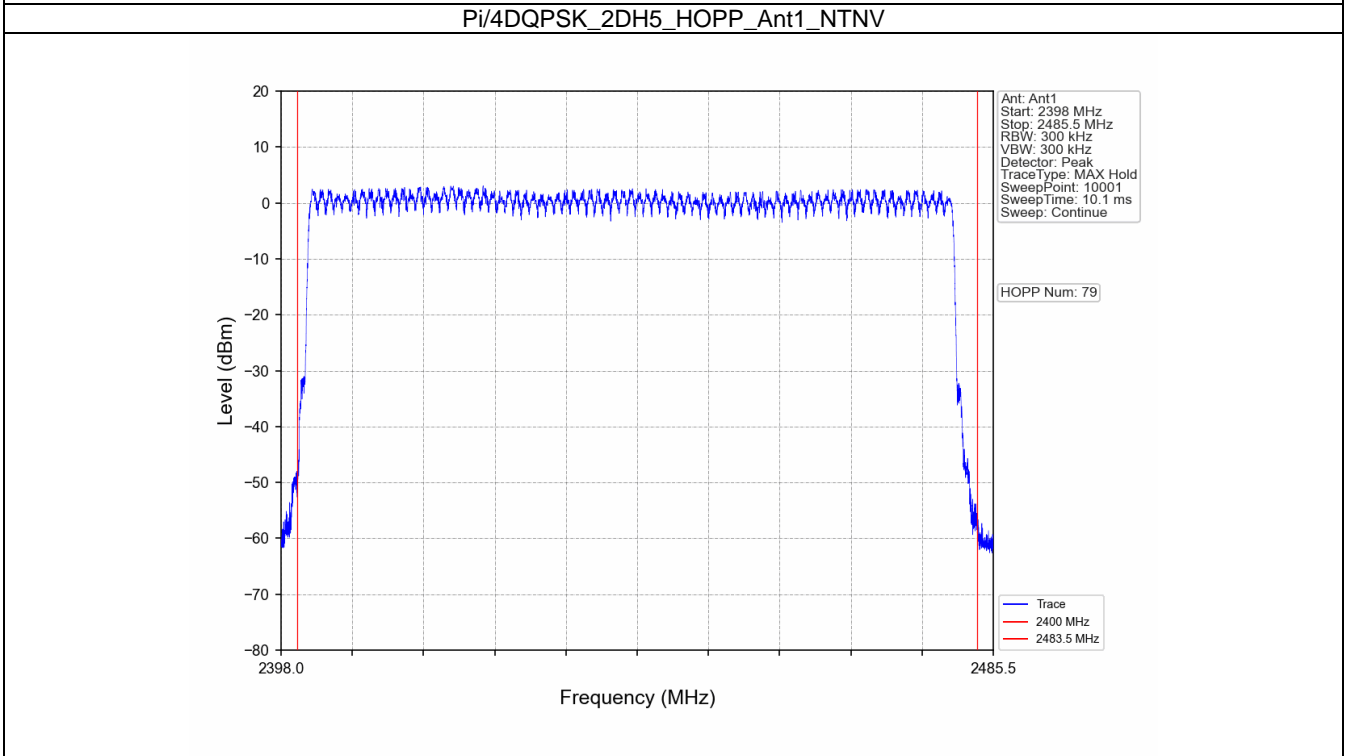
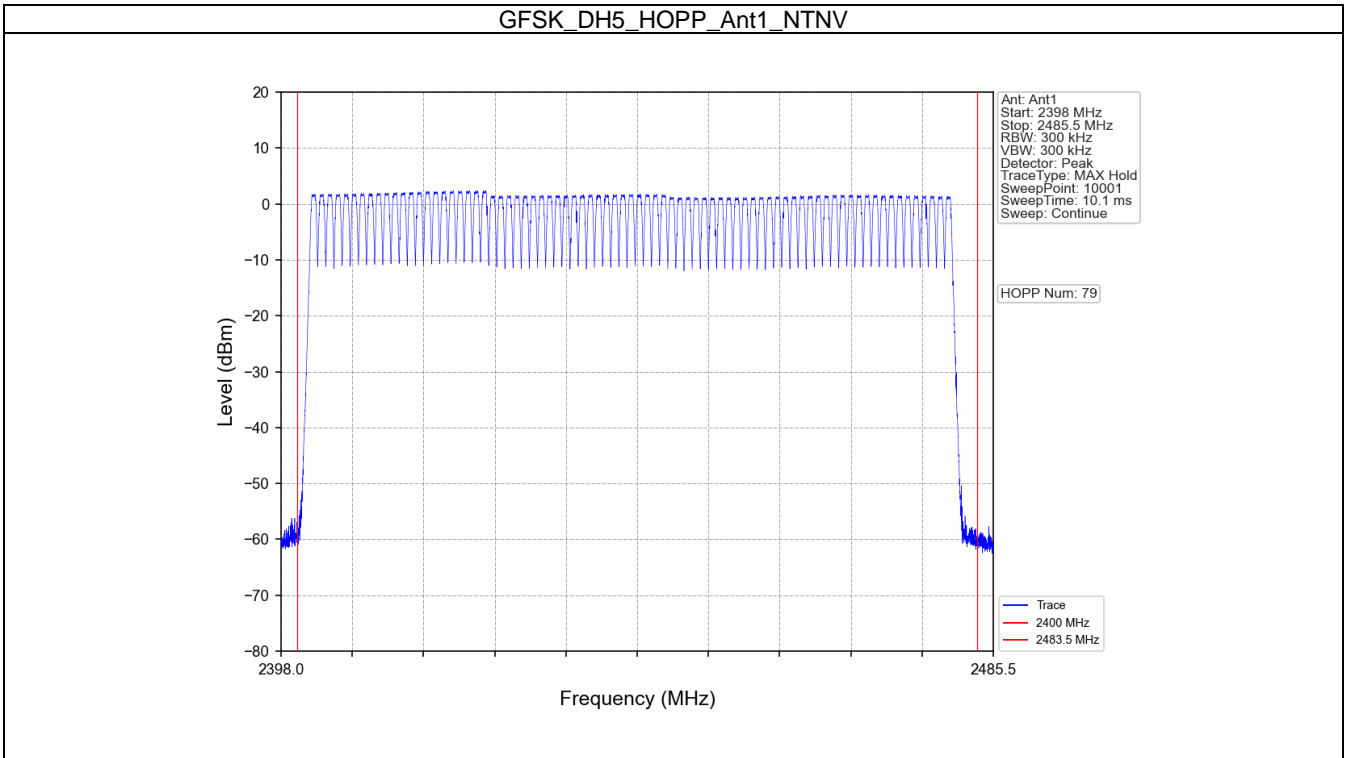

8DPSK_3DH5_HOPP_Ant1_NTNV

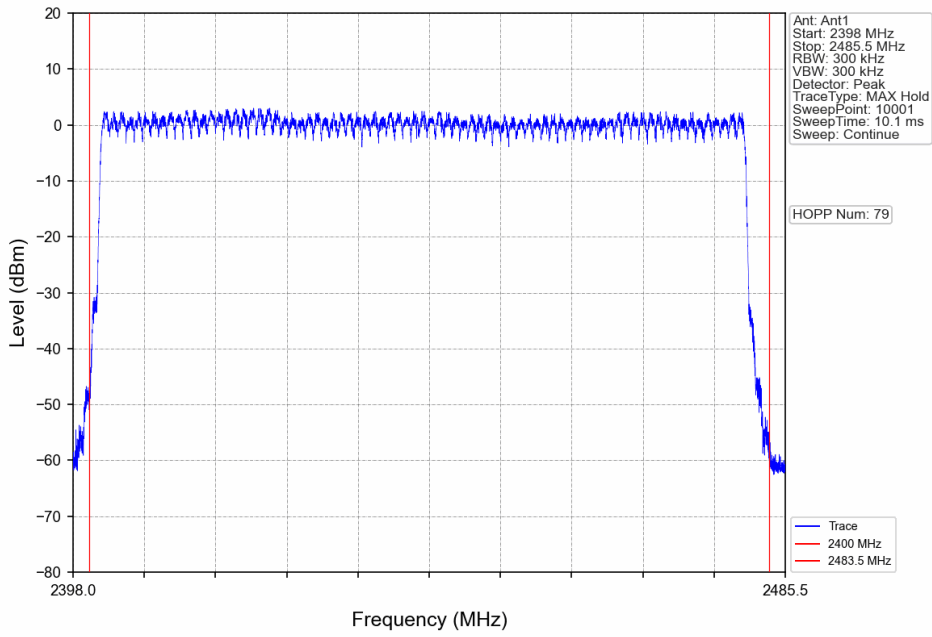

9.6 Dwell Time

Test Method

1. The RF output of EUT was connected to the spectrum analyzer by RF cable. The path loss was compensated to the results for each measurement.
2. Set to the maximum power setting and enable the EUT transmit to hopping mode.
3. Span: Zero span, centered on a hopping channel.
4. RBW shall be \leq channel spacing and where possible RBW should be set $\gg 1 / T$, where T is the expected dwell time per channel.
5. Sweep: As necessary to capture the entire dwell time per hopping channel; where possible use a video trigger and trigger delay so that the transmitted signal starts a little to the right of the start of the plot. The trigger level might need slight adjustment to prevent triggering when the system hops on an adjacent channel; a second plot might be needed with a longer sweep time to show two successive hops on a channel.
6. Detector function: Peak.
7. Trace: Max hold. Use the marker-delta function to determine the transmit time per hop. If this value varies with different modes of operation (data rate, modulation format, number of hopping channels, etc.), then repeat this test for each variation in transmit time.

Limit

The average time of occupancy on any frequency shall not be greater than 0.4 seconds within a period of 0.4 seconds multiplied by the number of hopping channels employed.

Test Results

Mode	Frequency (MHz)	Packet Type	Duration of Single Pulse (ms)	Observation Period (s)	Num of Pulse in Observation Period	Dwell Time (ms)	Limit (ms)	Verdict
GFSK	HOPP	DH1	0.394	31.600	320	126.080	≤ 400	Pass
		DH3	1.650	31.600	160	264.000	≤ 400	Pass
		DH5	2.898	31.600	99	286.902	≤ 400	Pass
Pi/4DQPSK	HOPP	2DH1	0.404	31.600	320	129.280	≤ 400	Pass
		2DH3	1.656	31.600	162	268.272	≤ 400	Pass
		2DH5	2.894	31.600	104	300.976	≤ 400	Pass
8DPSK	HOPP	3DH1	0.396	31.600	320	126.720	≤ 400	Pass
		3DH3	1.654	31.600	162	267.948	≤ 400	Pass
		3DH5	2.906	31.600	117	340.002	≤ 400	Pass

Test Graphs

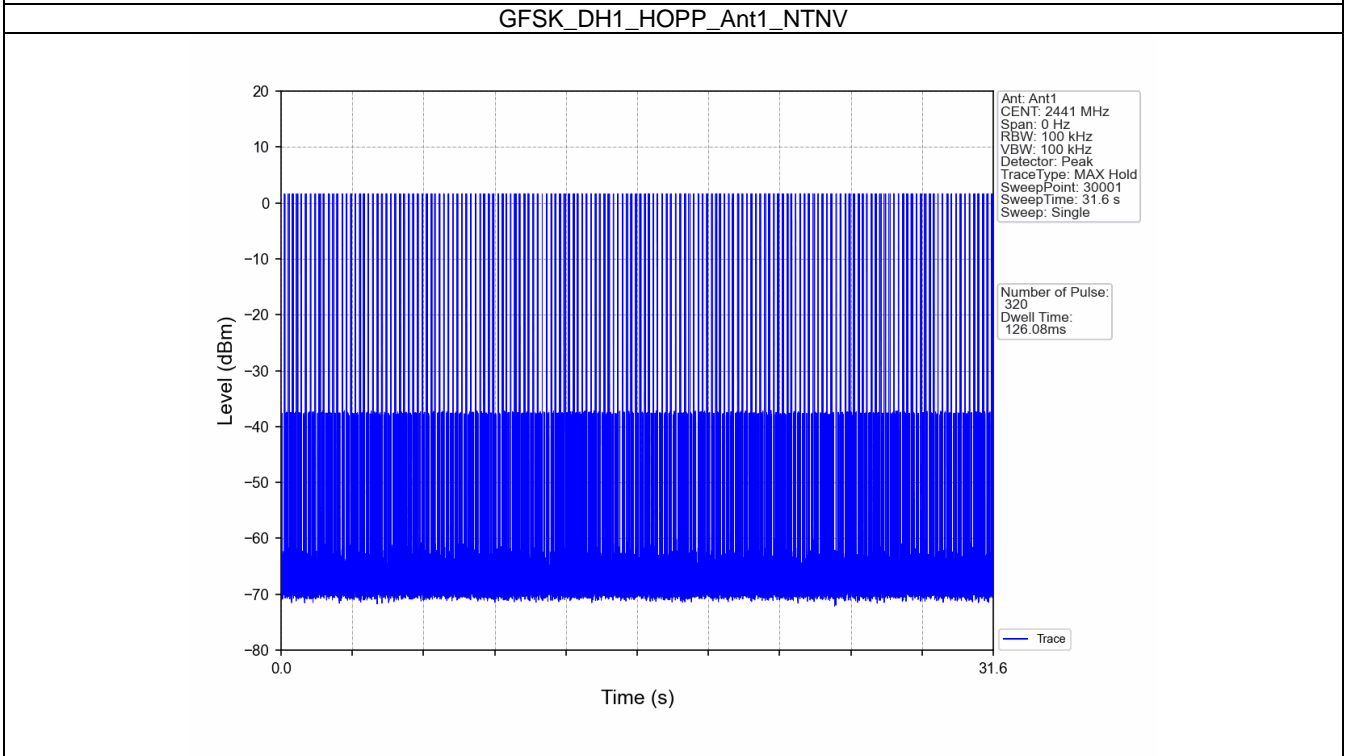
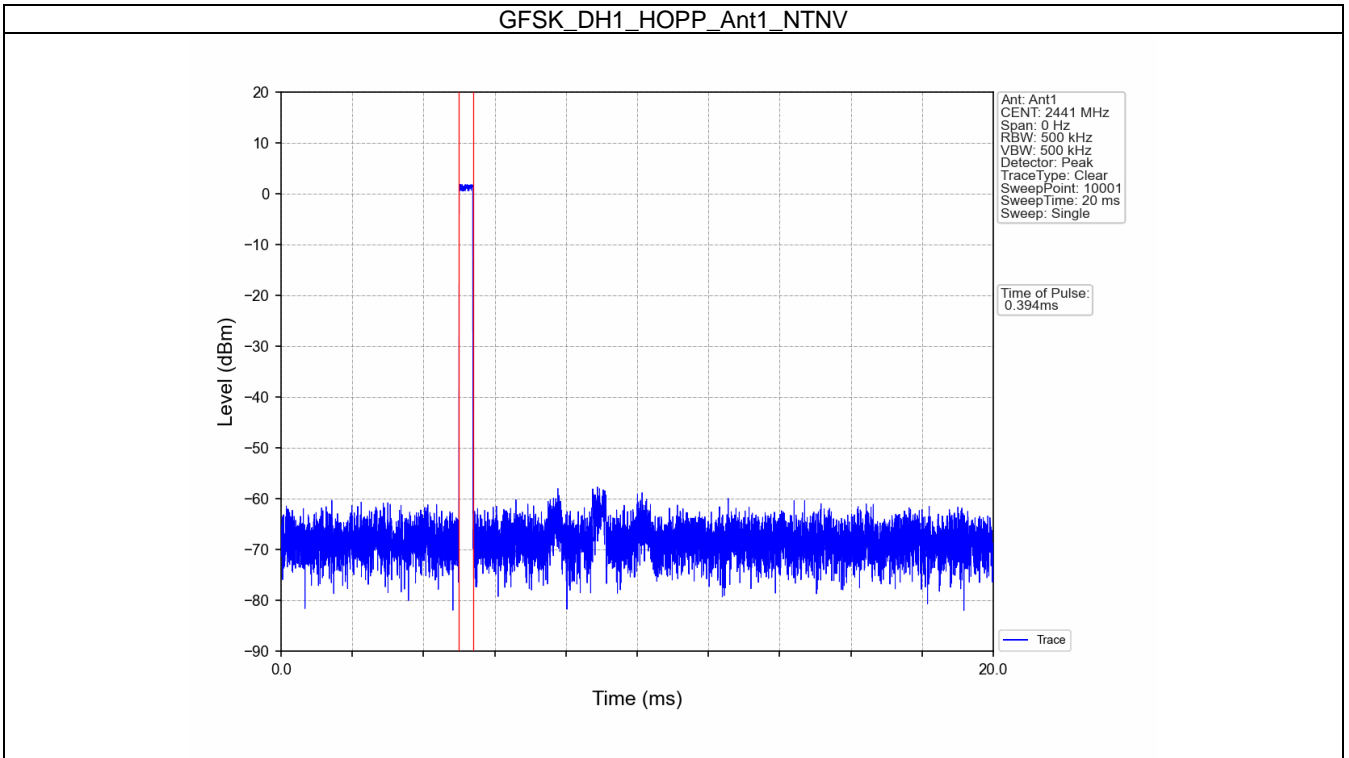

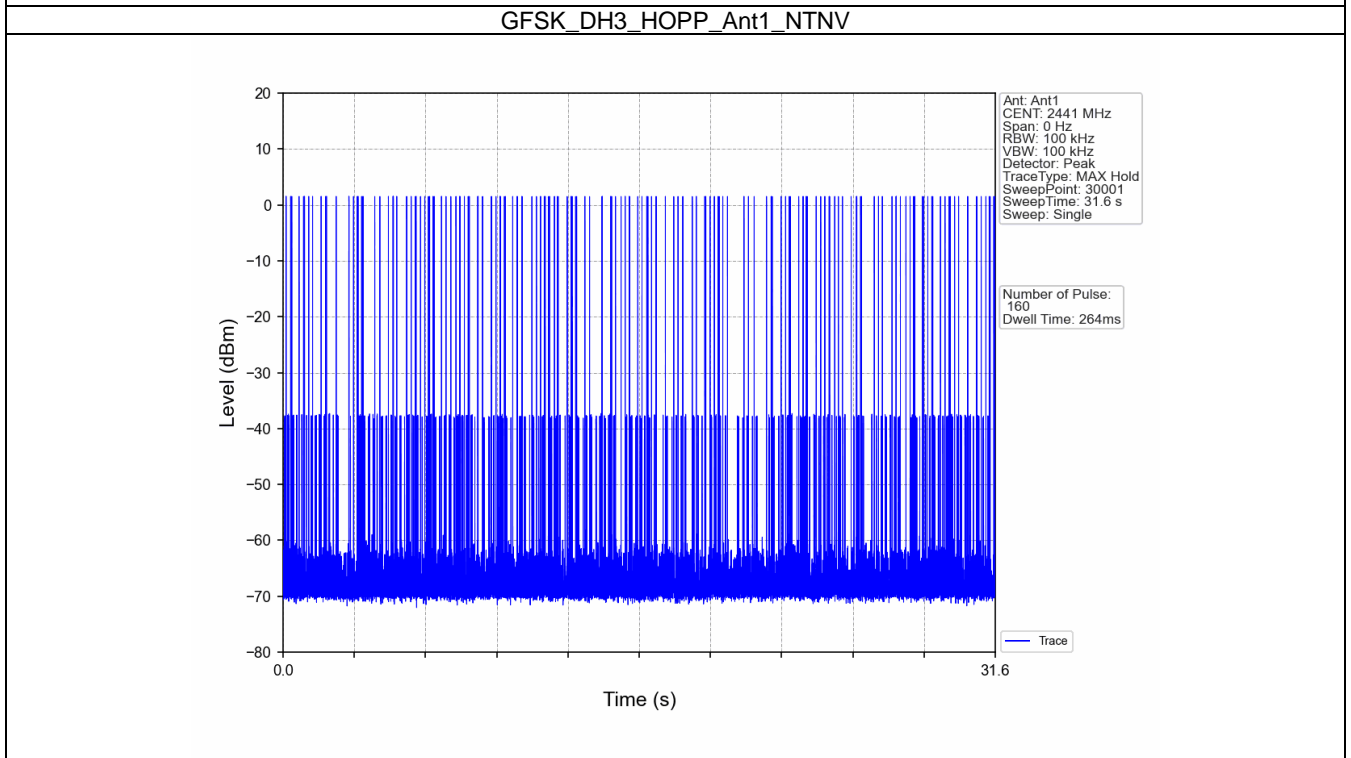
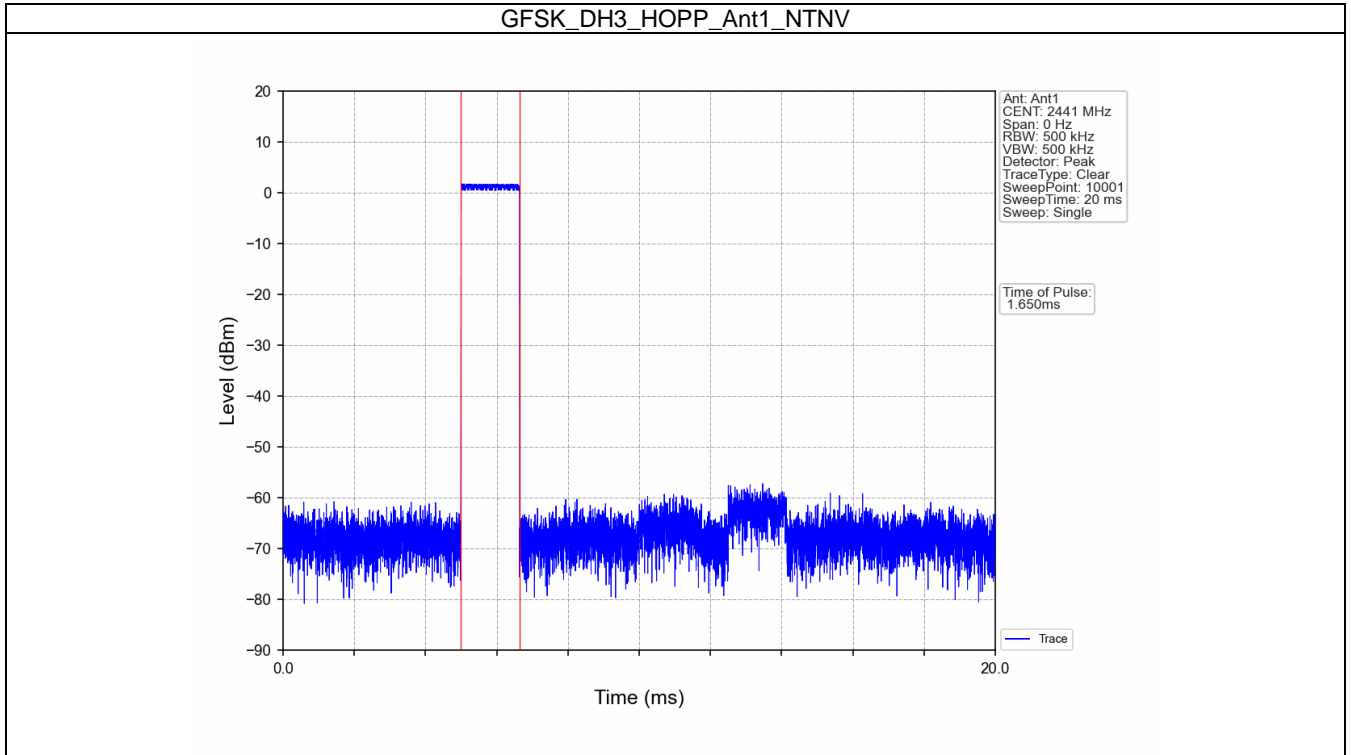

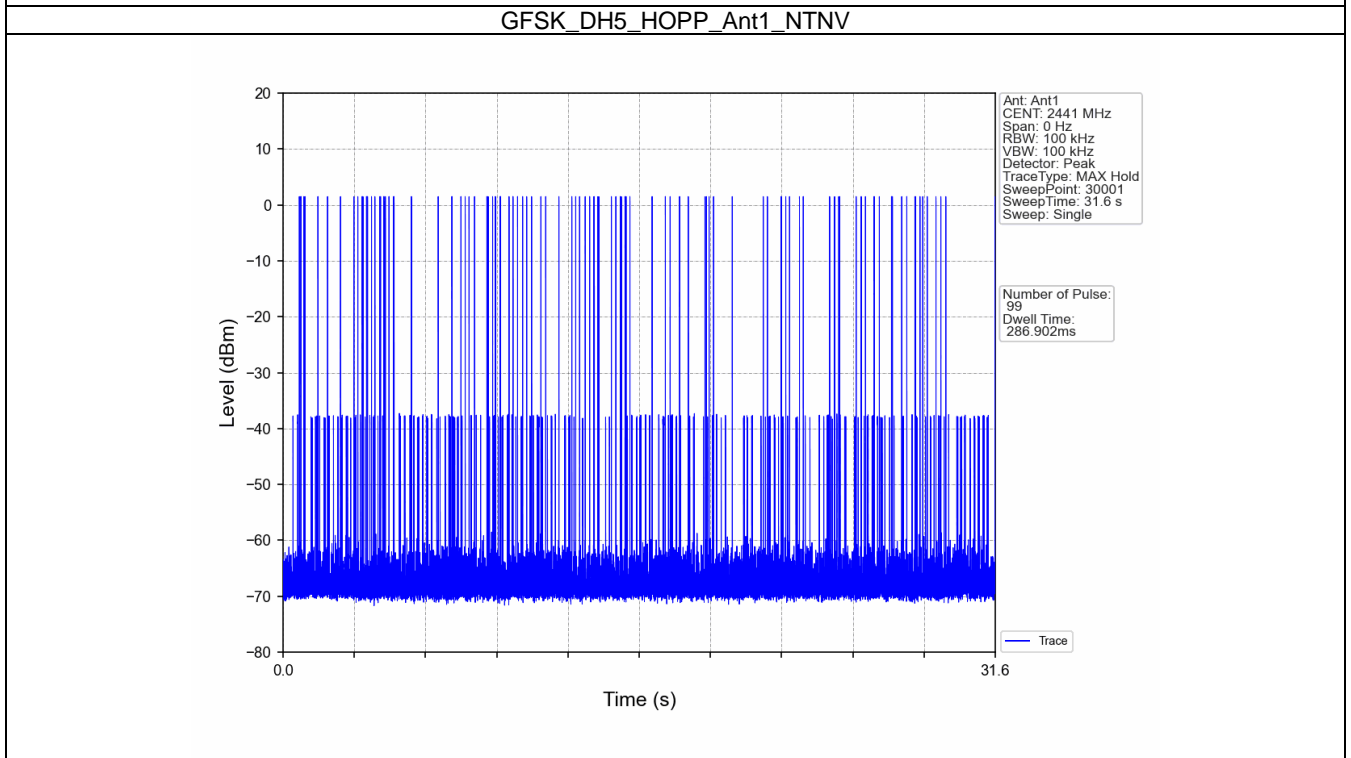
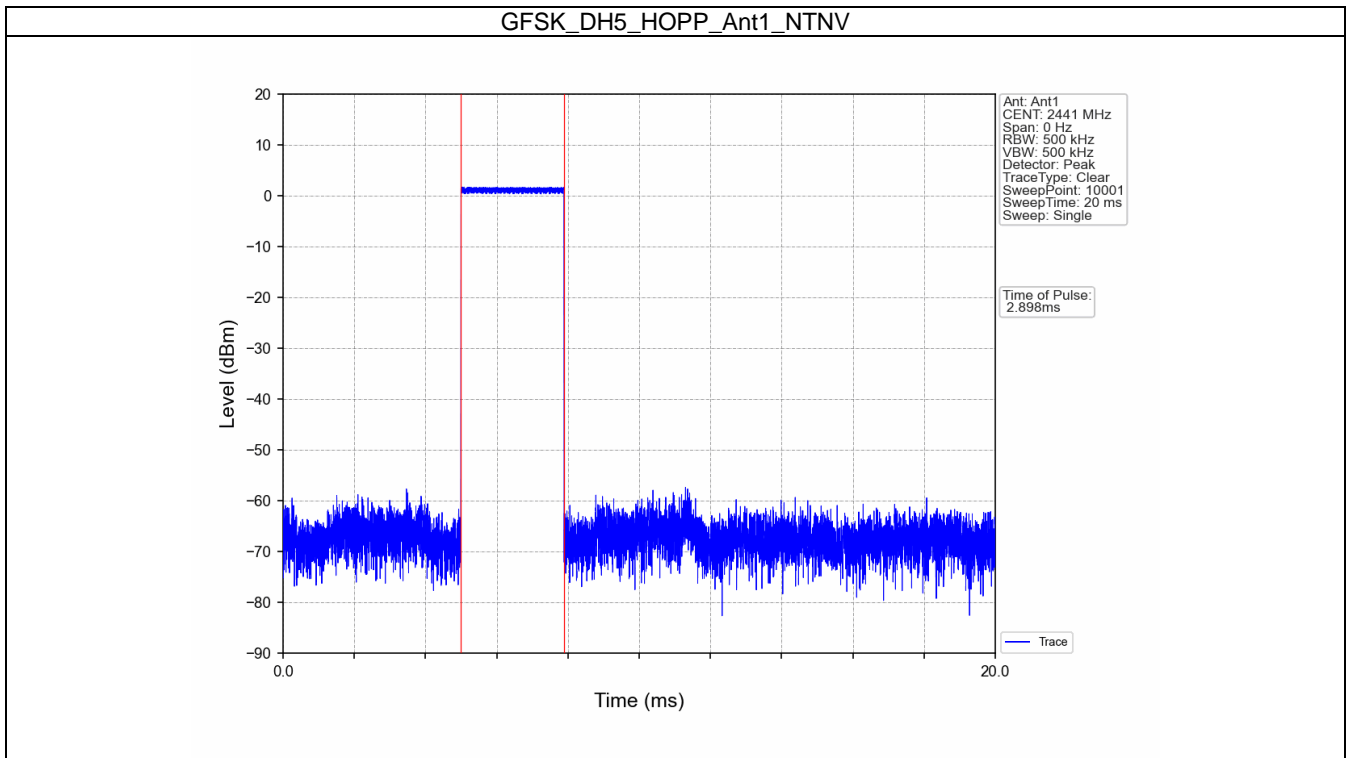

Pi/4DQPSK_2DH1_HOPP_Ant1_NTNV

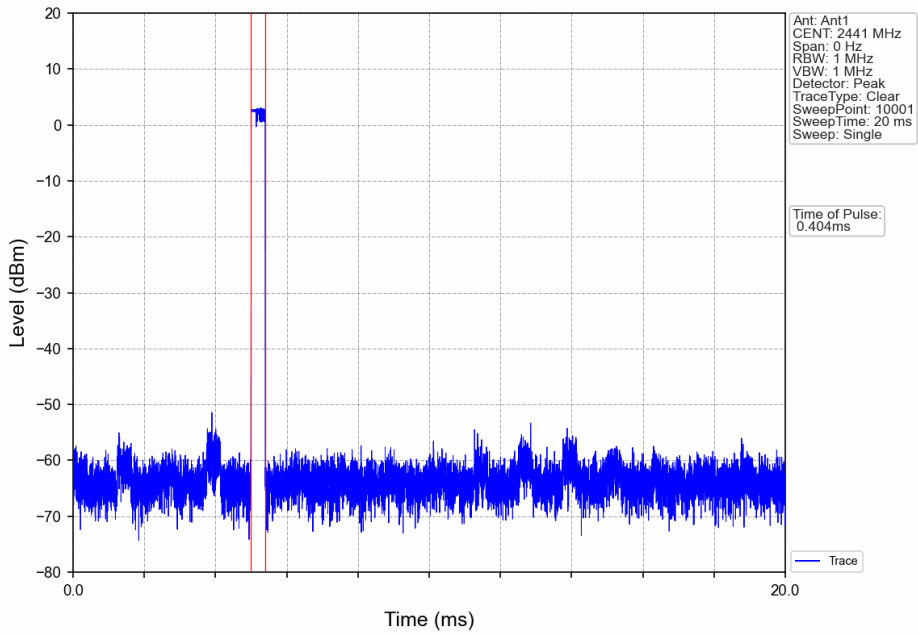

Pi/4DQPSK_2DH1_HOPP_Ant1_NTNV

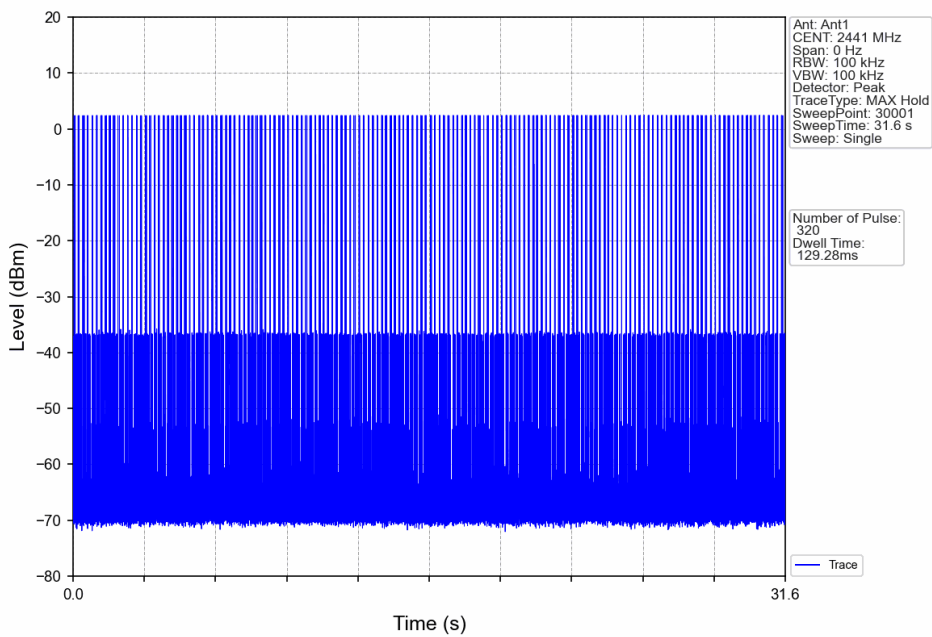

Pi/4DQPSK_2DH3_HOPP_Ant1_NTNV

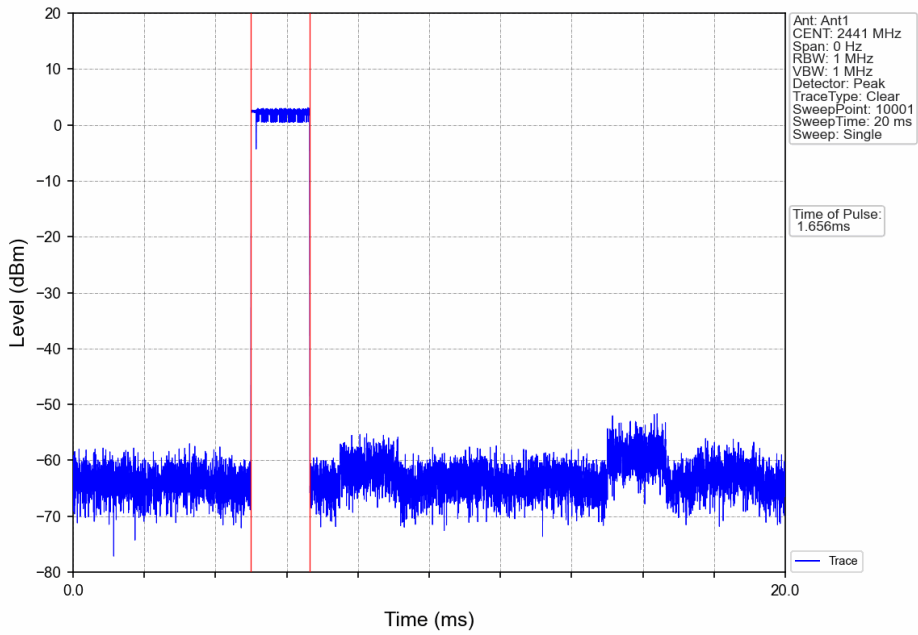

Pi/4DQPSK_2DH3_HOPP_Ant1_NTNV

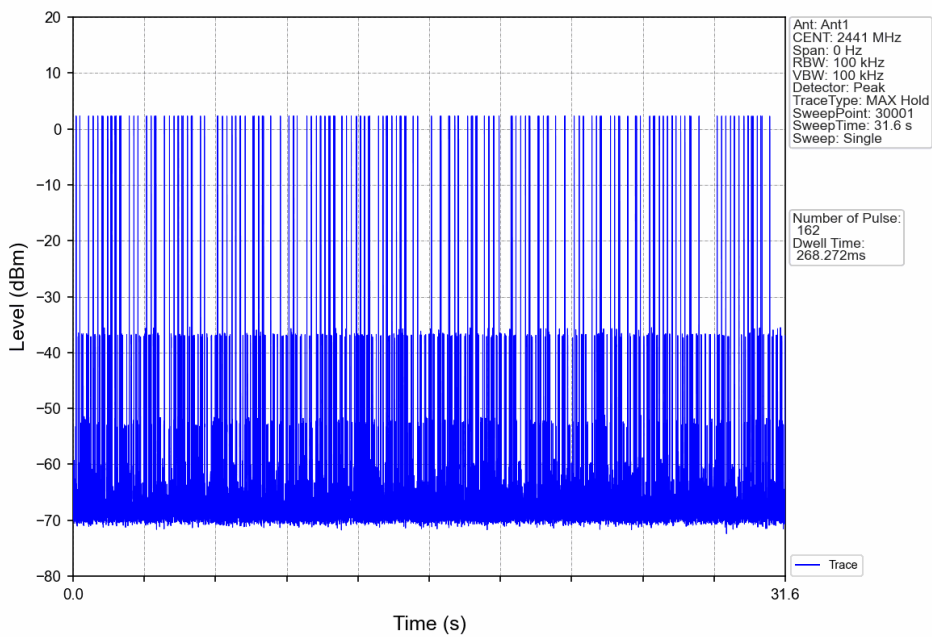

Pi/4DQPSK_2DH5_HOPP_Ant1_NTNV

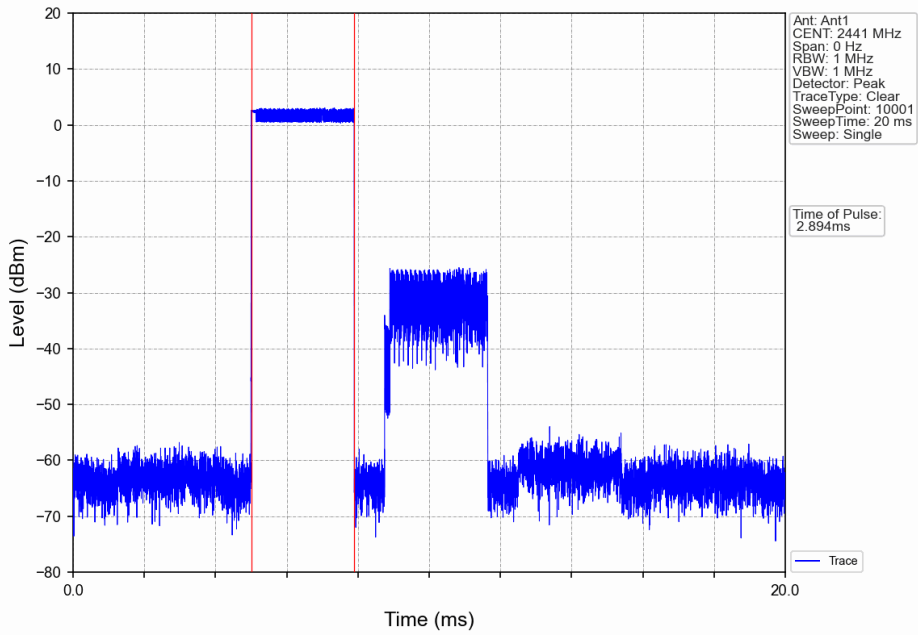

Pi/4DQPSK_2DH5_HOPP_Ant1_NTNV

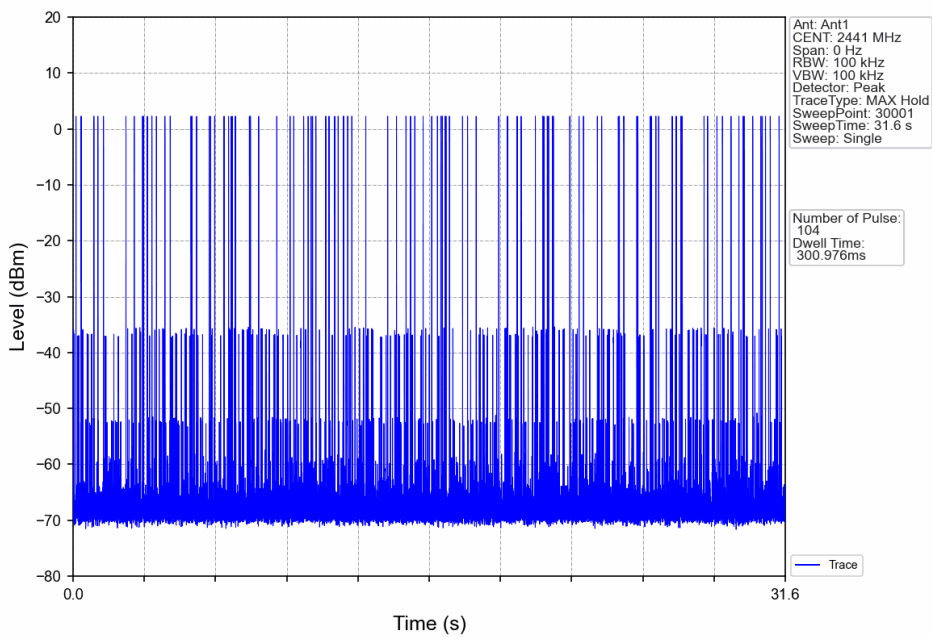

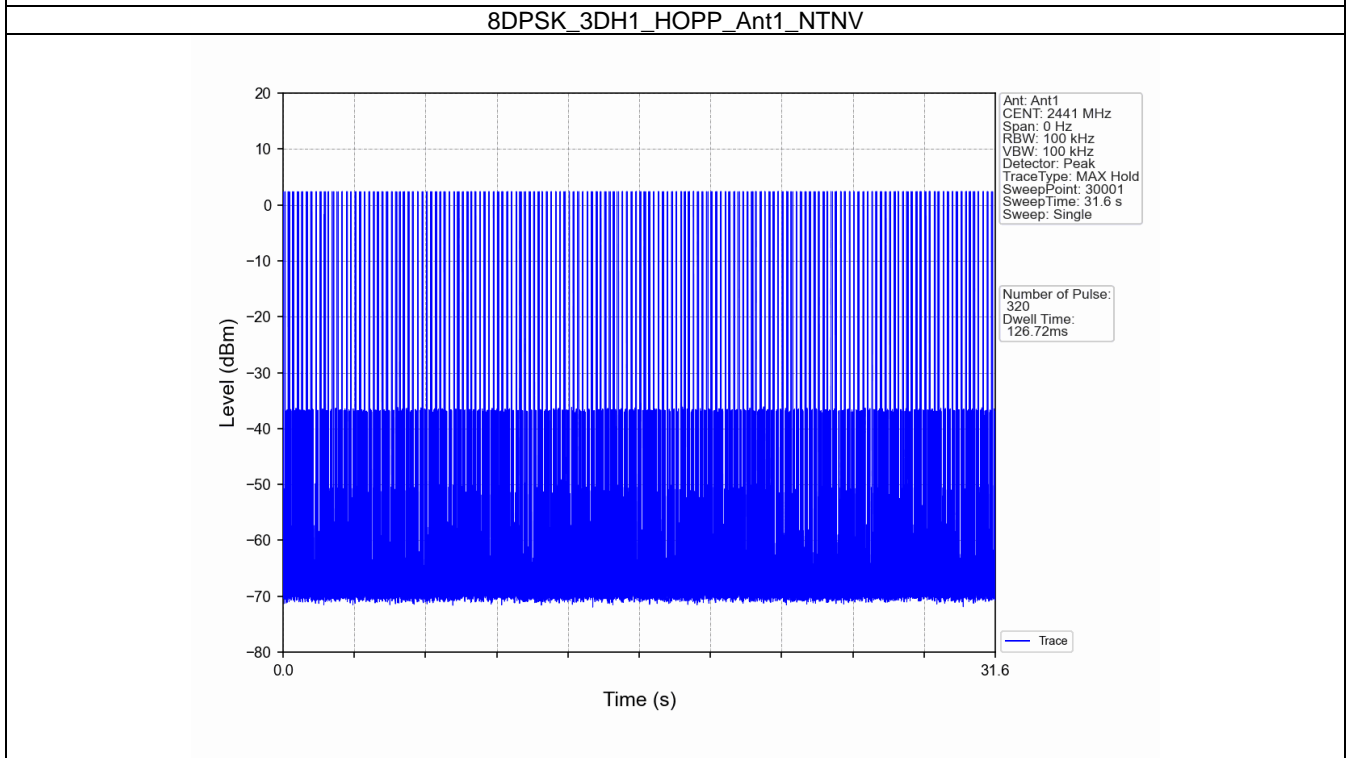
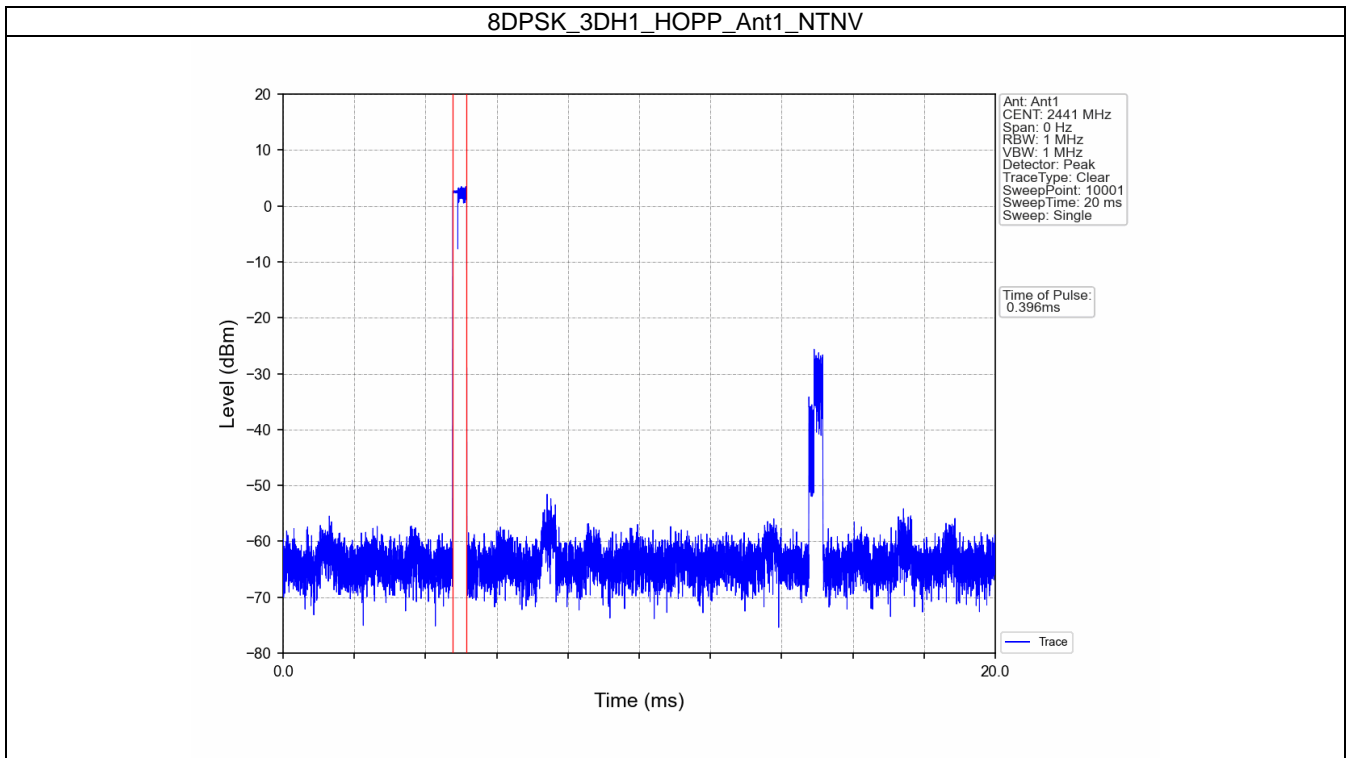

8DPSK_3DH3_HOPP_Ant1_NTNV

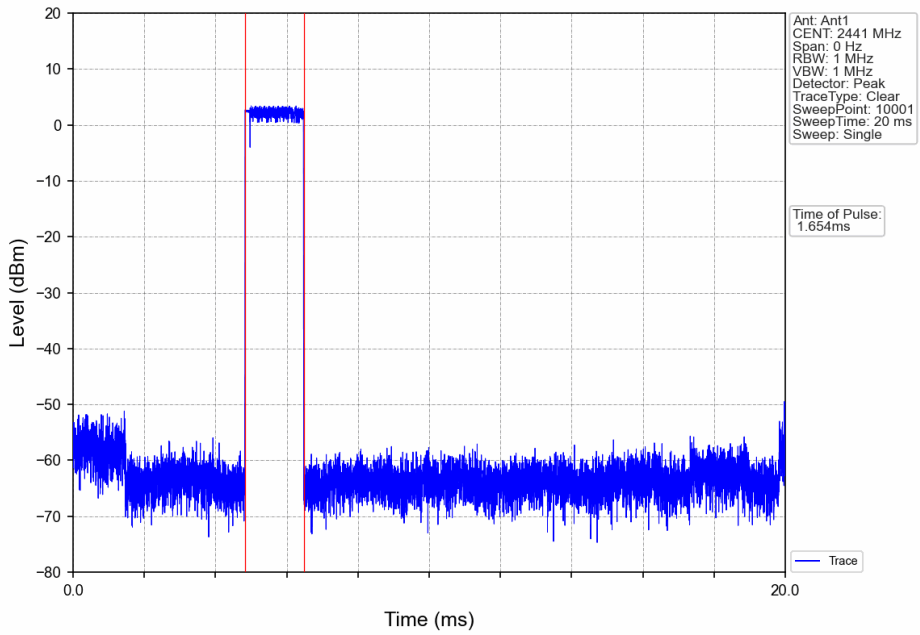

8DPSK_3DH3_HOPP_Ant1_NTNV

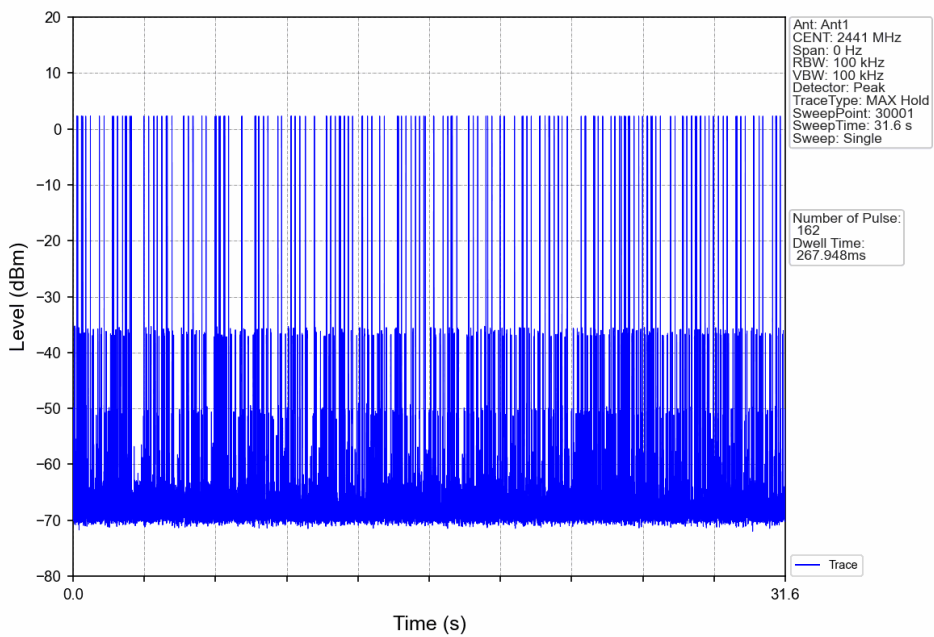

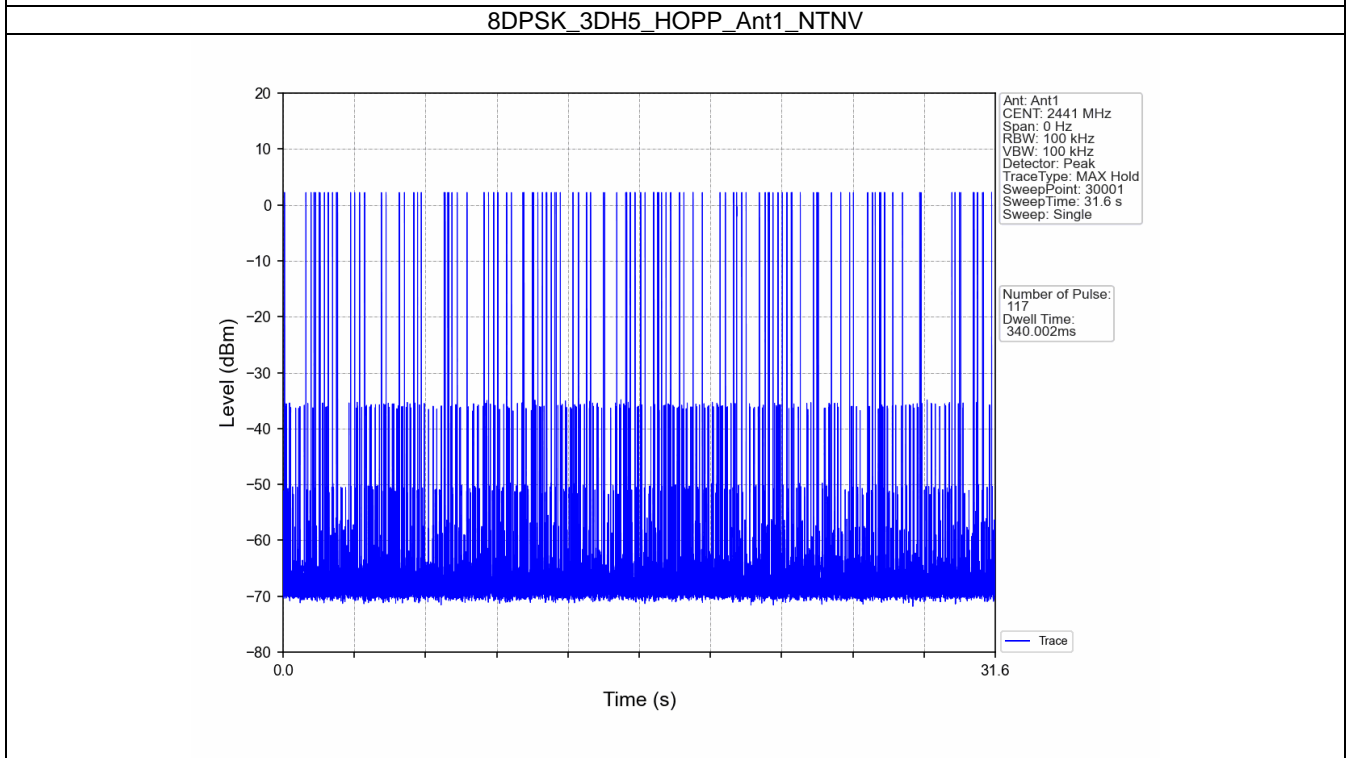
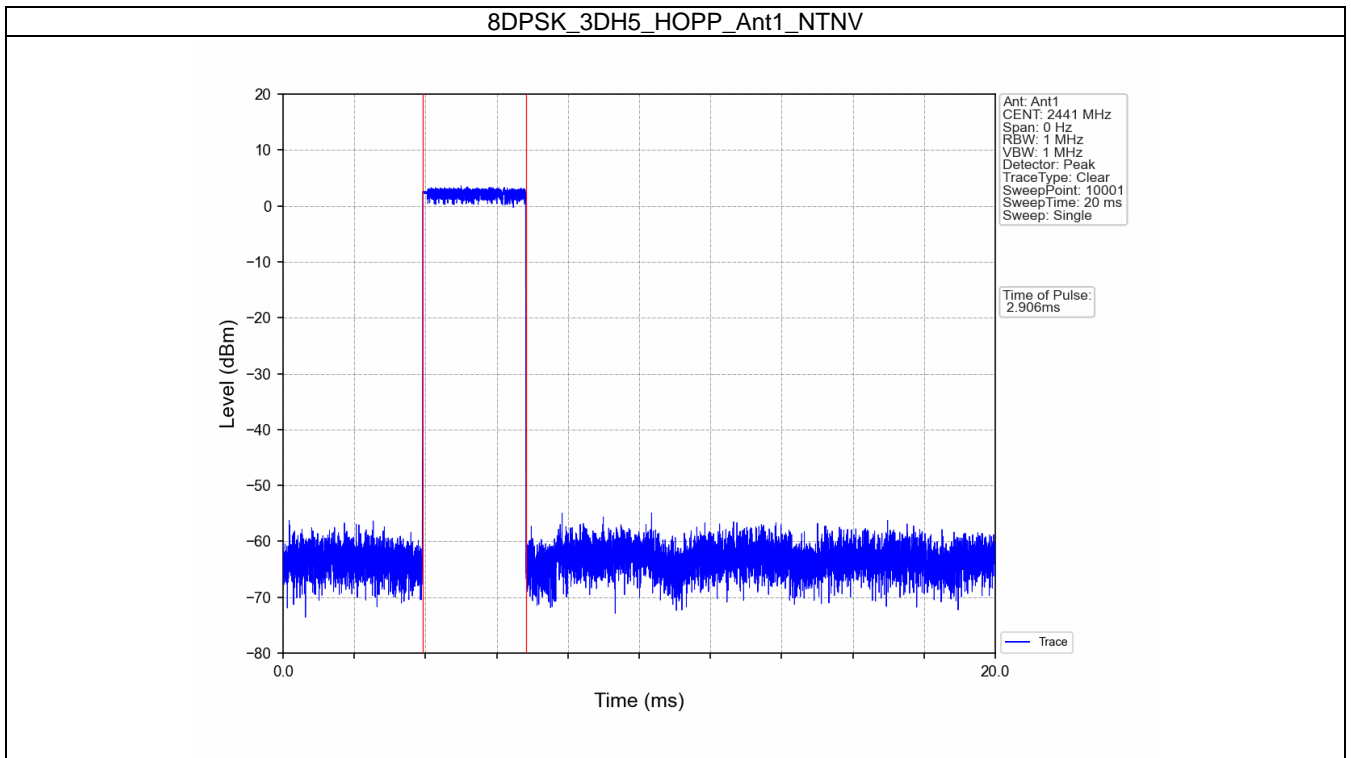

9.7 Spurious RF Conducted Emissions

Test Method

1. The RF output of EUT was connected to the spectrum analyzer by RF cable. The path loss was compensated to the results for each measurement.
2. Set to the maximum power setting and enable the EUT transmit continuously.
3. Set RBW = 100 kHz, VBW=300 kHz, Peak Detector, Sweep = auto, Span = wide enough to capture the peak level of the in-band emission and all spurious emissions, Trace = max hold. Allow the trace to stabilize. Set the marker on the peak of any spurious emission recorded. The level displayed must comply with the limit specified in this Section.
4. Measure and record the results in the test report.
5. The RF fundamental frequency should be excluded against the limit line in the operating frequency

Limit

Frequency Range MHz	Limit (dBc)
30-25000	-20

Test Results

Mode	Frequency (MHz)	Packet Type	Level of Reference (dBm)	Limit (dBm)	Verdict
GFSK	2402	DH5	2.17	-17.83	Pass
	2441	DH5	2.16	-17.84	Pass
	2480	DH5	1.91	-18.09	Pass
	HOPP	DH5	2.45	-17.55	Pass
			2.45	-17.55	Pass
Pi/4DQPSK	2402	2DH5	3.17	-16.83	Pass
	2441	2DH5	3.24	-16.76	Pass
	2480	2DH5	2.95	-17.05	Pass
	HOPP	2DH5	2.76	-17.24	Pass
			2.76	-17.24	Pass
8DPSK	2402	3DH5	3.16	-16.84	Pass
	2441	3DH5	3.20	-16.80	Pass
	2480	3DH5	2.93	-17.07	Pass
	HOPP	3DH5	2.55	-17.45	Pass
			2.55	-17.45	Pass

Note1: Refer to FCC Part 15.247 (d) and ANSI C63.10-2013, the channel contains the maximum PSD level was used to establish the reference level.

Test Graphs

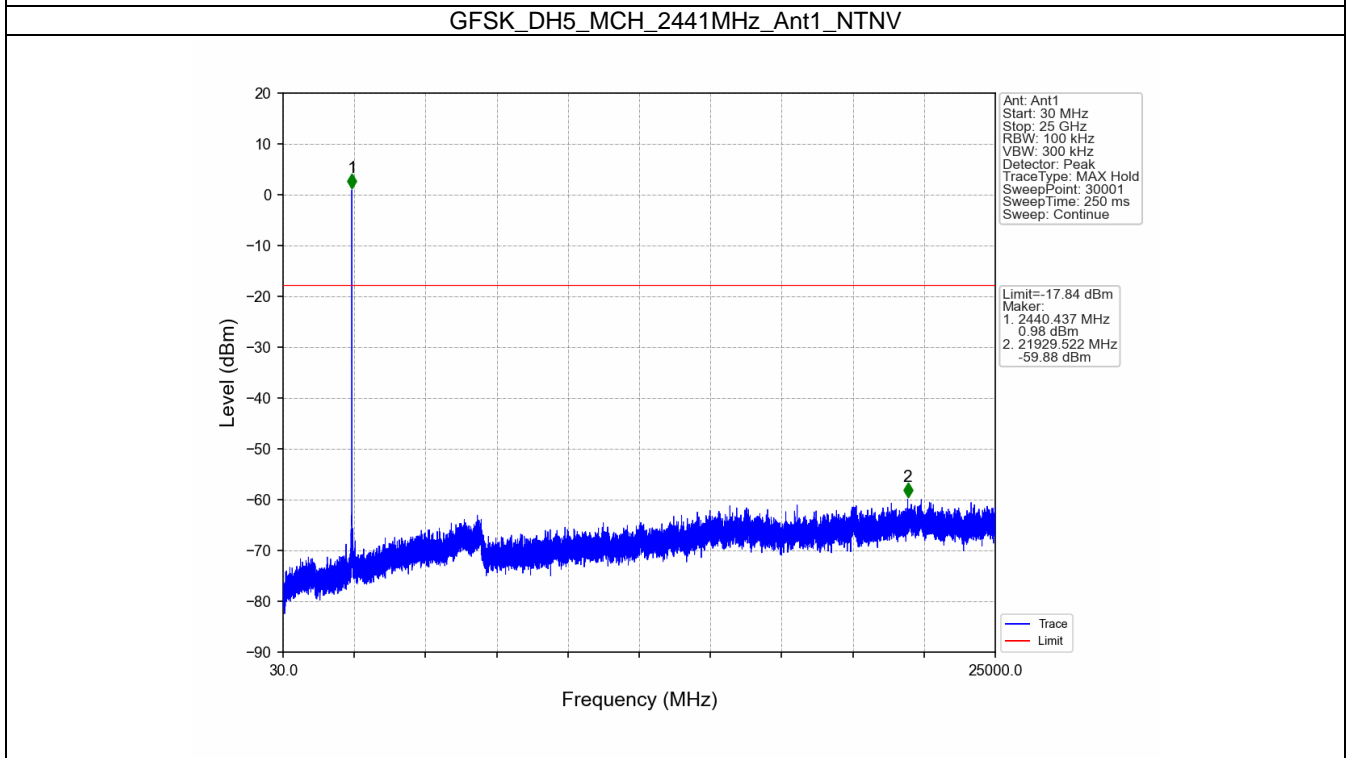
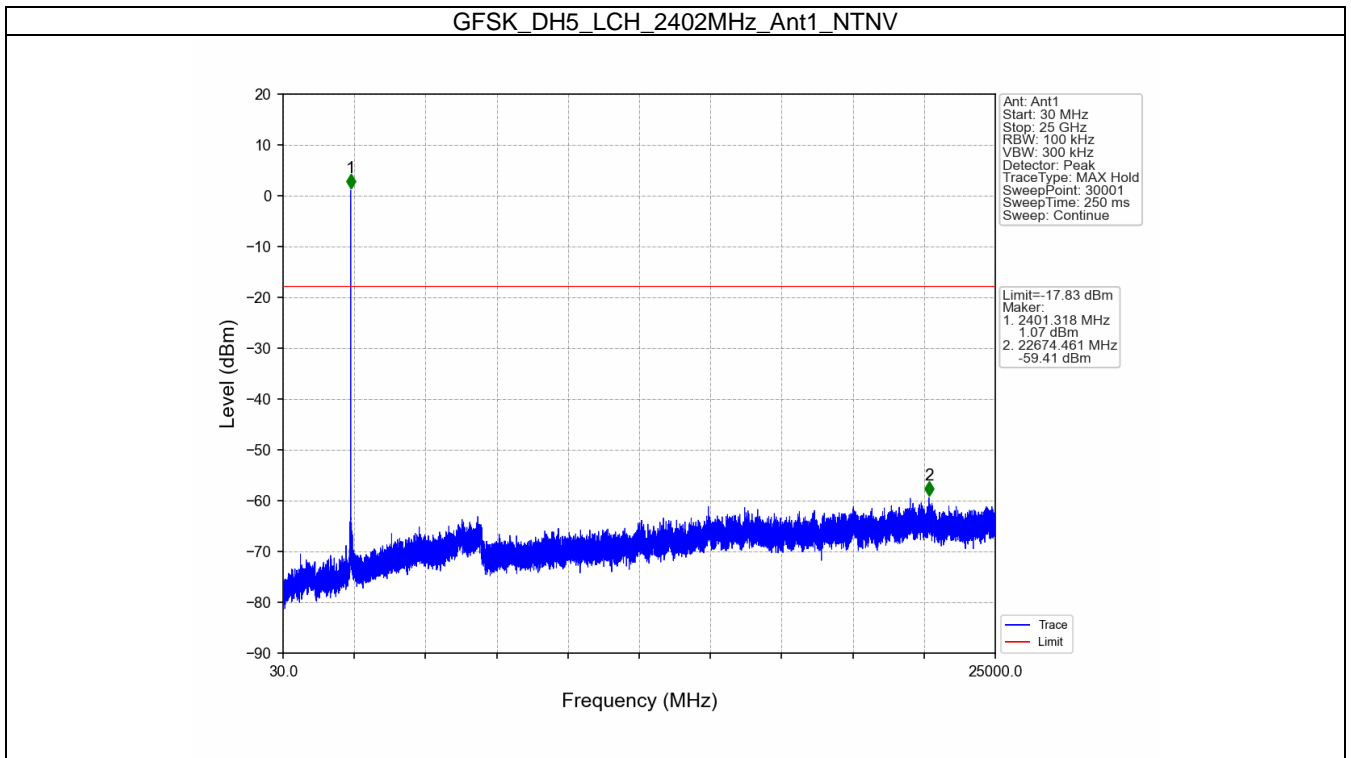

GFSK_DH5_HCH_2480MHz_Ant1_NTNV

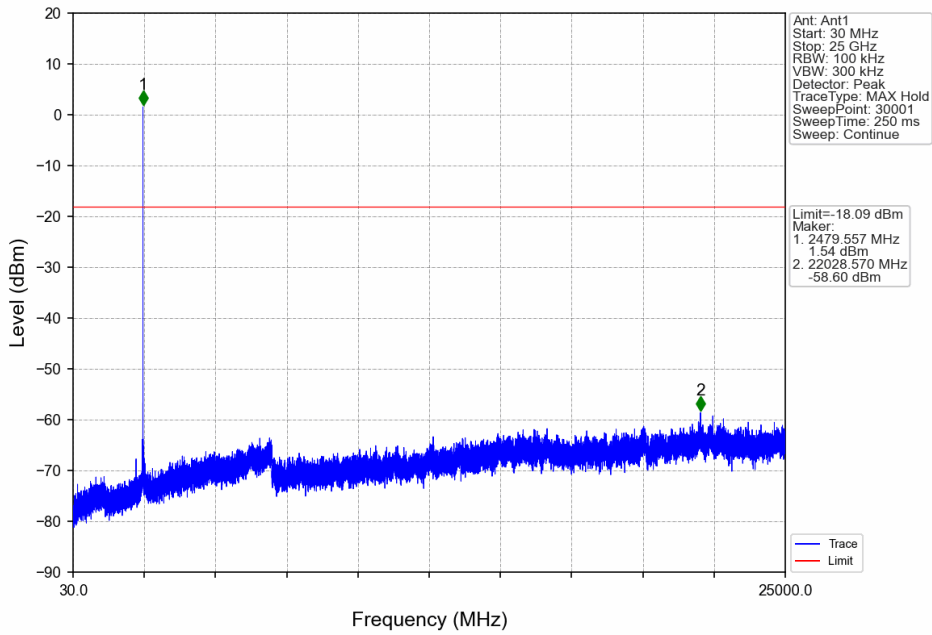

Pi/4DQPSK_2DH5_LCH_2402MHz_Ant1_NTNV

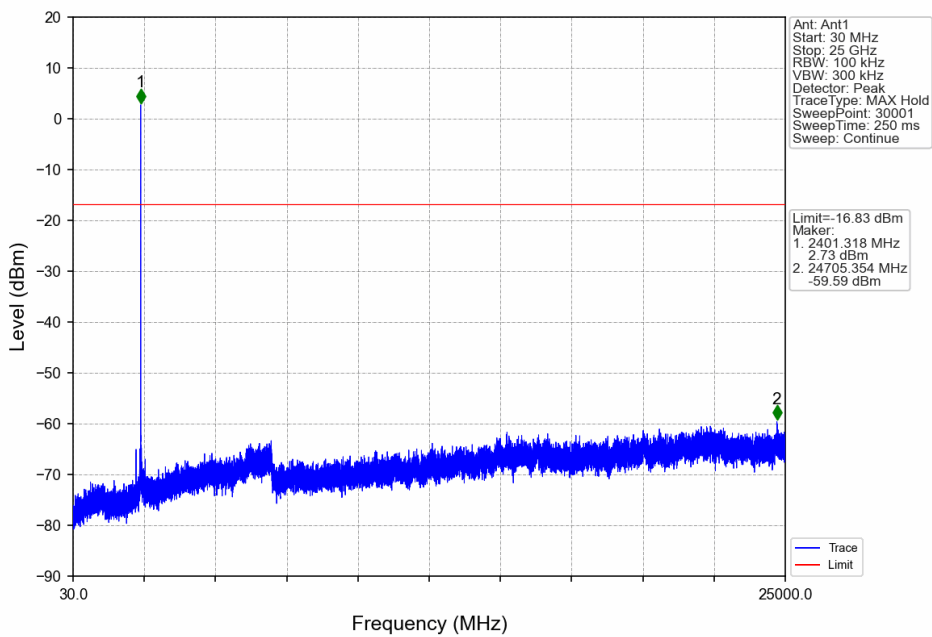

Pi/4DQPSK_2DH5_MCH_2441MHz_Ant1_NTNV

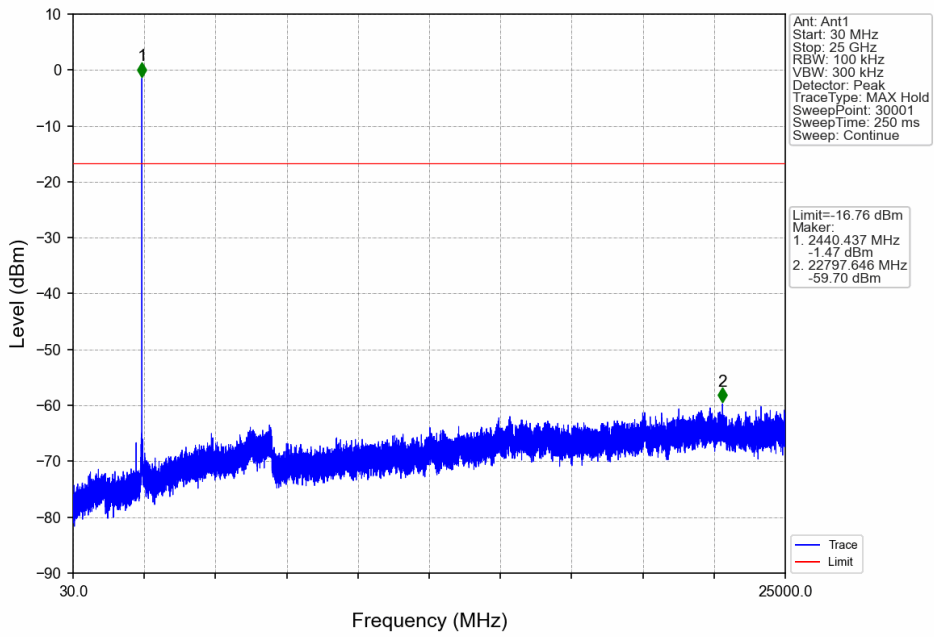

Pi/4DQPSK_2DH5_HCH_2480MHz_Ant1_NTNV

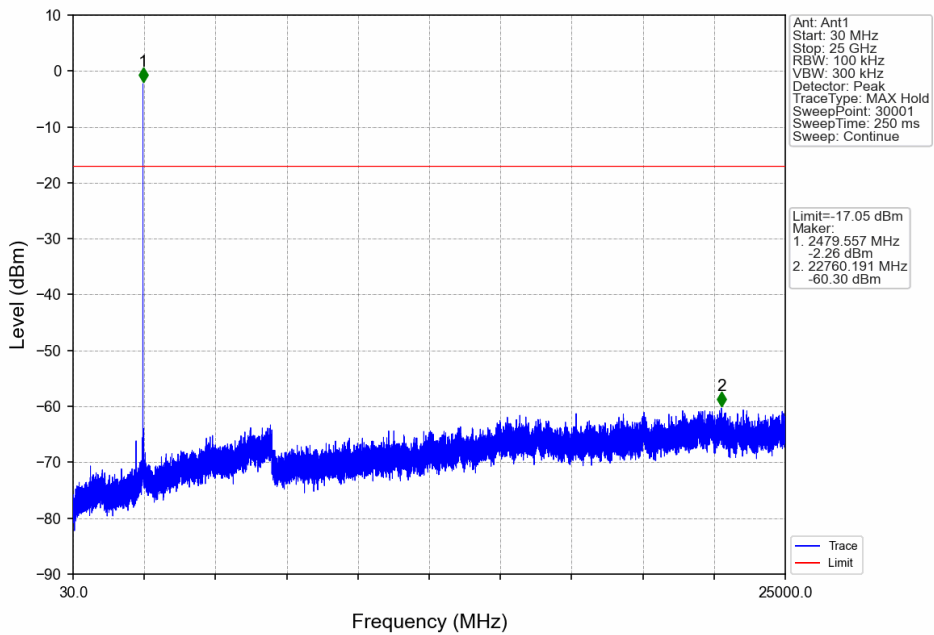

8DPSK_3DH5_LCH_2402MHz_Ant1_NTNV

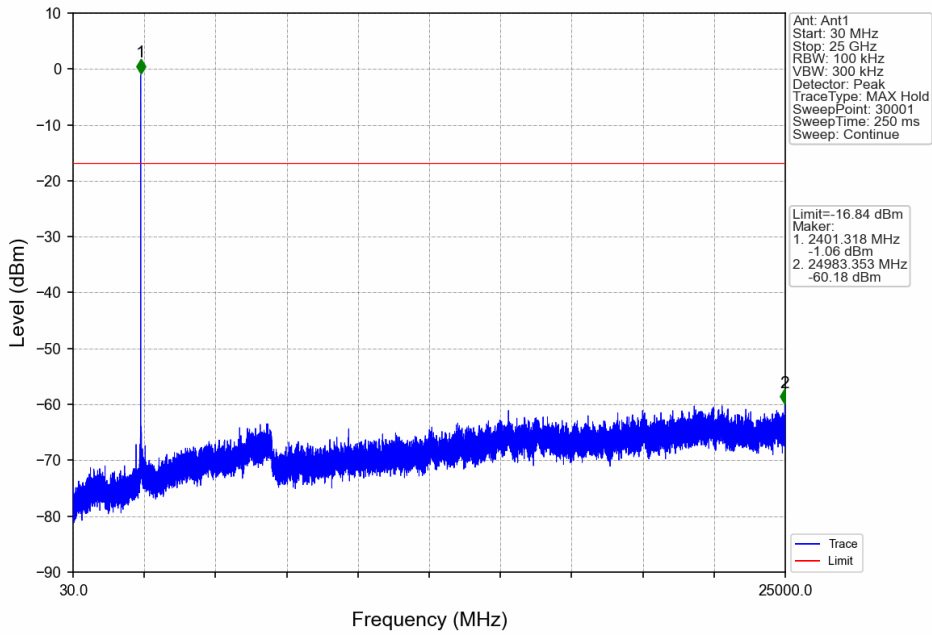

8DPSK_3DH5_MCH_2441MHz_Ant1_NTNV

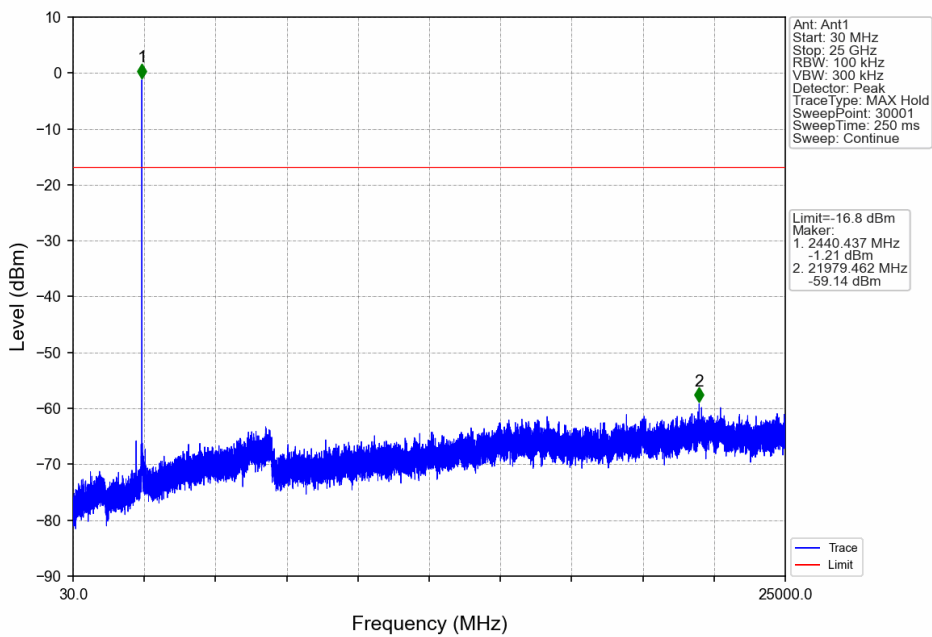

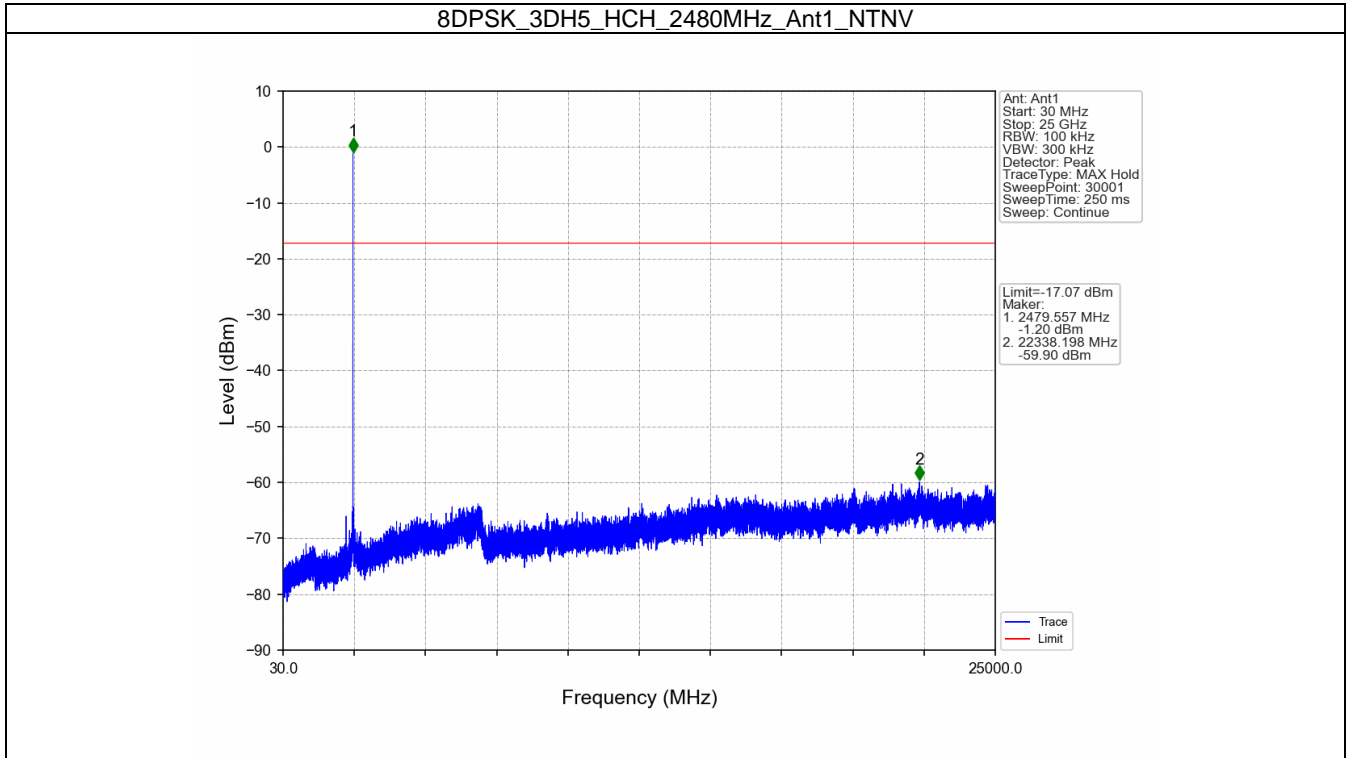

9.8 Band Edge Testing

Test Method

1. The RF output of EUT was connected to the test receiver by RF cable. The path loss was compensated to the results for each measurement.
2. Set to the maximum power setting and enable the EUT transmit continuously. Set the EUT to the lowest frequency channel.
3. Set RBW = 100 kHz, VBW=300 kHz, Peak Detector, Trace: Max hold, Sweep time: Coupled, Span: Wide enough to capture the peak level of the emission operating on the channel closest to the band edge, as well as any modulation products that fall outside of the authorized band of operation. Allow the trace to stabilize.
4. Set the marker on the emission at the band edge, or on the highest modulation product outside of the band, if this level is greater than that at the band edge. Enable the marker-delta function, and then use the marker-to-peak function to move the marker to the peak of the in-band emission.
5. Set the EUT to the highest frequency channel and repeat step 2) to 4)
6. Enable the EUT hopping mode, repeat the test.

Limit:

In any 100kHz bandwidth outside the frequency band in which the spread spectrum or digitally modulated device is operating, the RF power that is produced shall be at least 20 dB below that in the 100 kHz bandwidth within the band that contains the highest level of the desired power, based on either an RF conducted or a radiated measurement, provided that the transmitter demonstrates compliance with the peak conducted power limits.

Test Results

Mode	Frequency (MHz)	Packet Type	Level of Reference (dBm)	Limit (dBm)	Verdict
GFSK	2402	DH5	2.17	-17.83	Pass
	2480	DH5	1.91	-18.09	Pass
	HOPP	DH5	2.45	-17.55	Pass
			2.45	-17.55	Pass
Pi/4DQPSK	2402	2DH5	3.17	-16.83	Pass
	2480	2DH5	2.95	-17.05	Pass
	HOPP	2DH5	2.76	-17.24	Pass
			2.76	-17.24	Pass
8DPSK	2402	3DH5	3.16	-16.84	Pass
	2480	3DH5	2.93	-17.07	Pass
	HOPP	3DH5	2.55	-17.45	Pass
			2.55	-17.45	Pass

Test Graphs

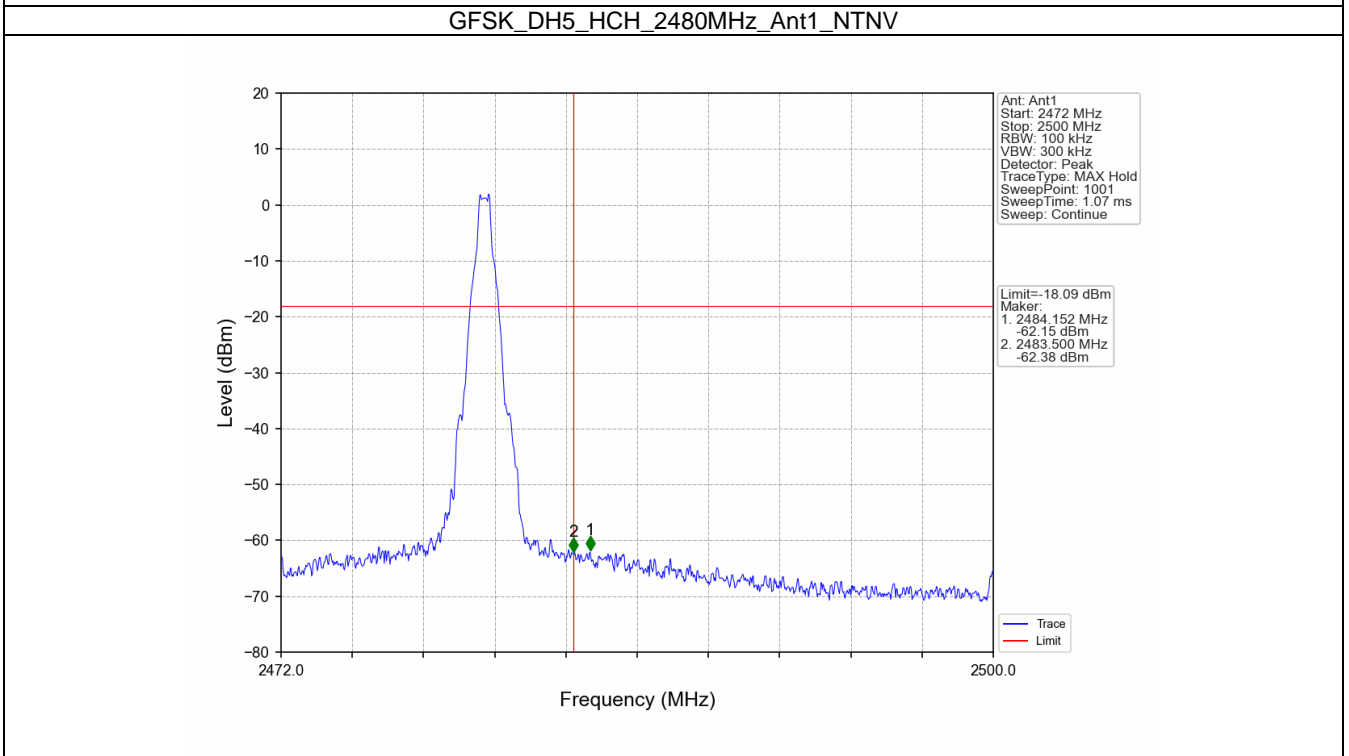
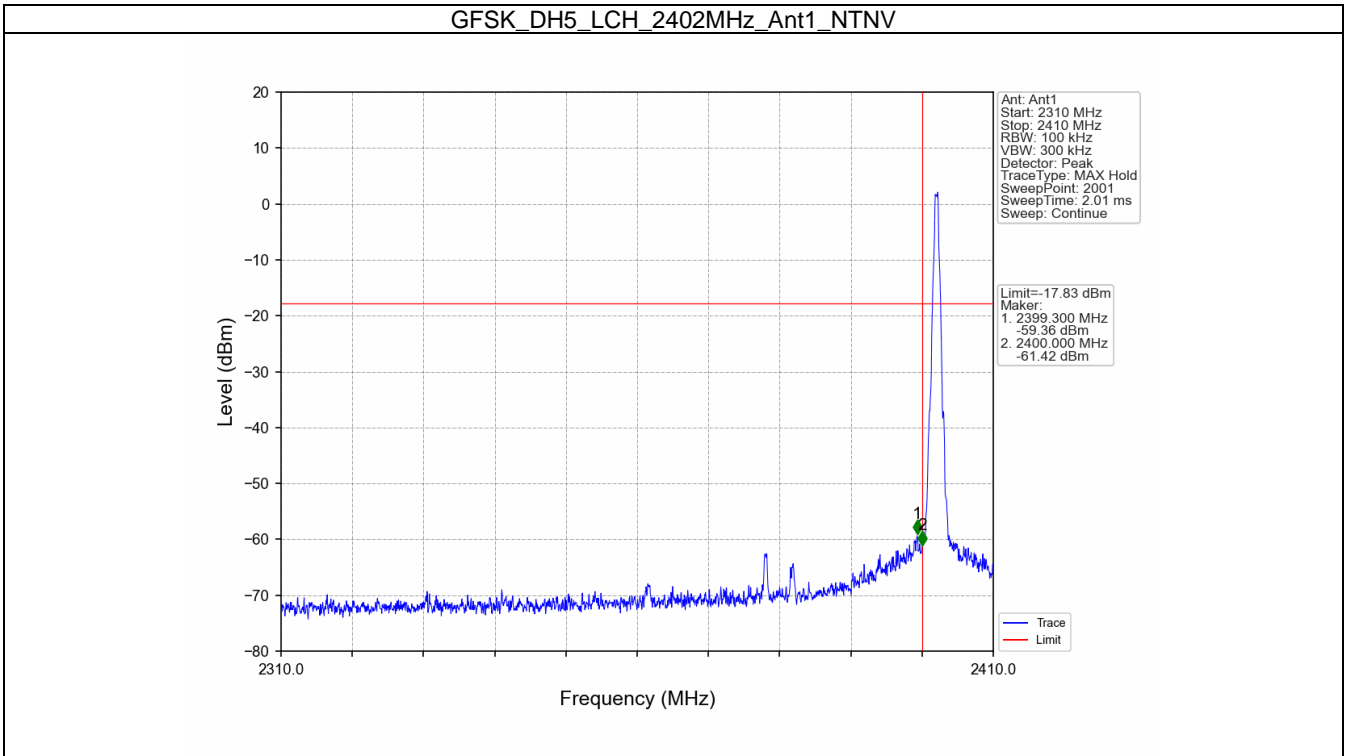

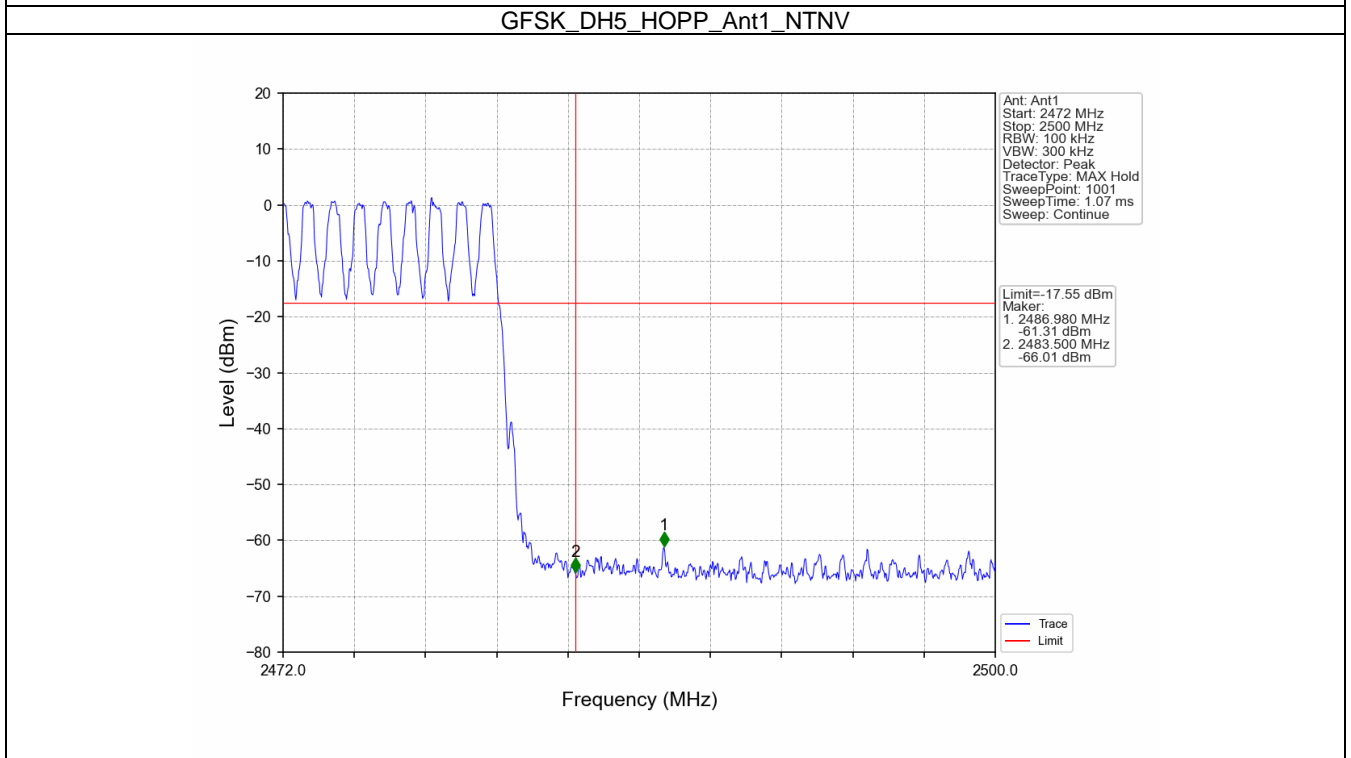
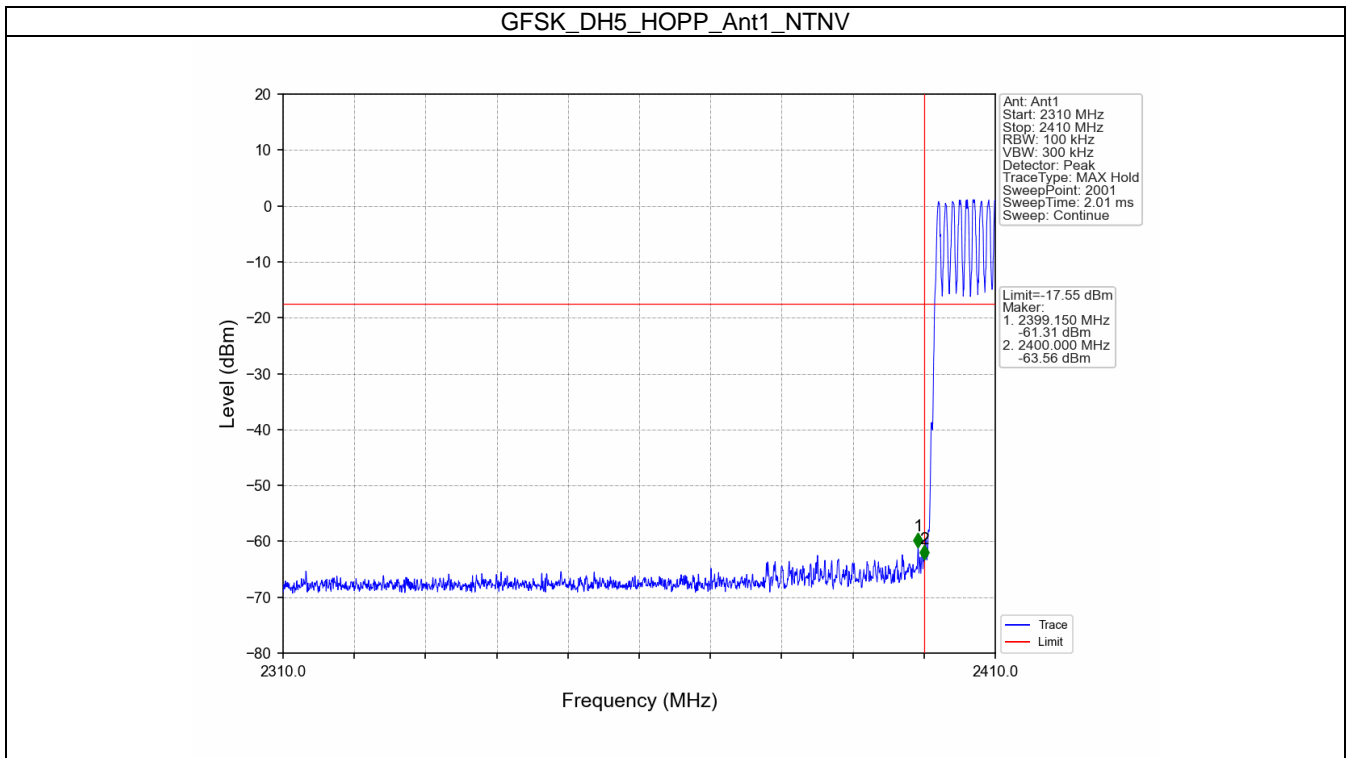

Pi/4DQPSK_2DH5_LCH_2402MHz_Ant1_NTNV

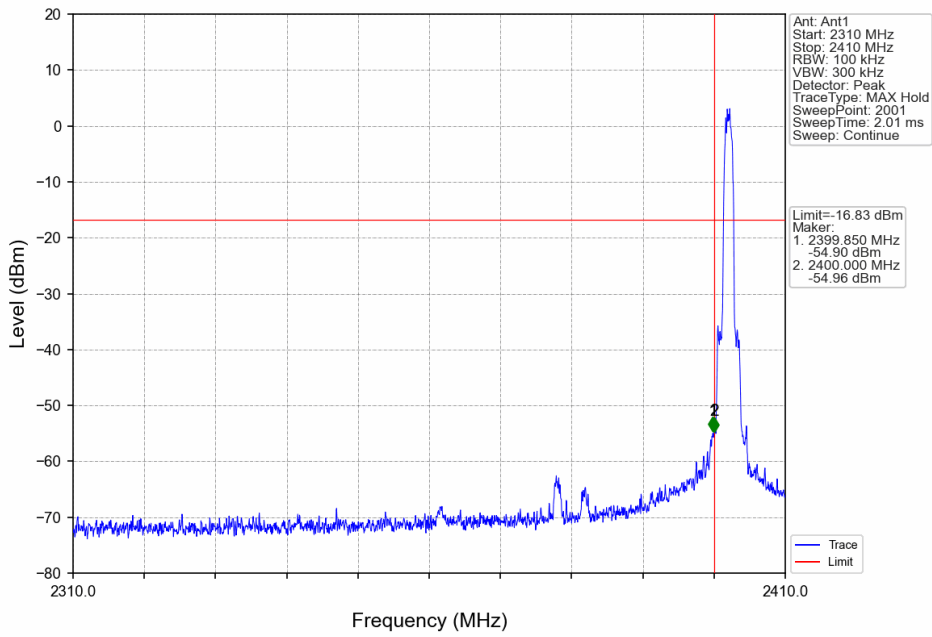

Pi/4DQPSK_2DH5_HCH_2480MHz_Ant1_NTNV

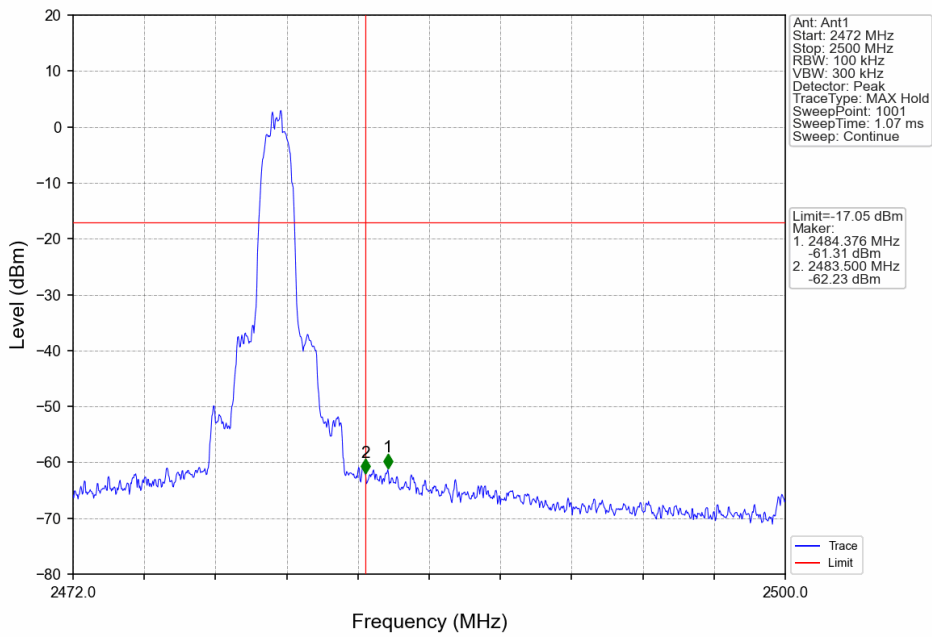

Pi/4DQPSK_2DH5_HOPP_Ant1_NTNV

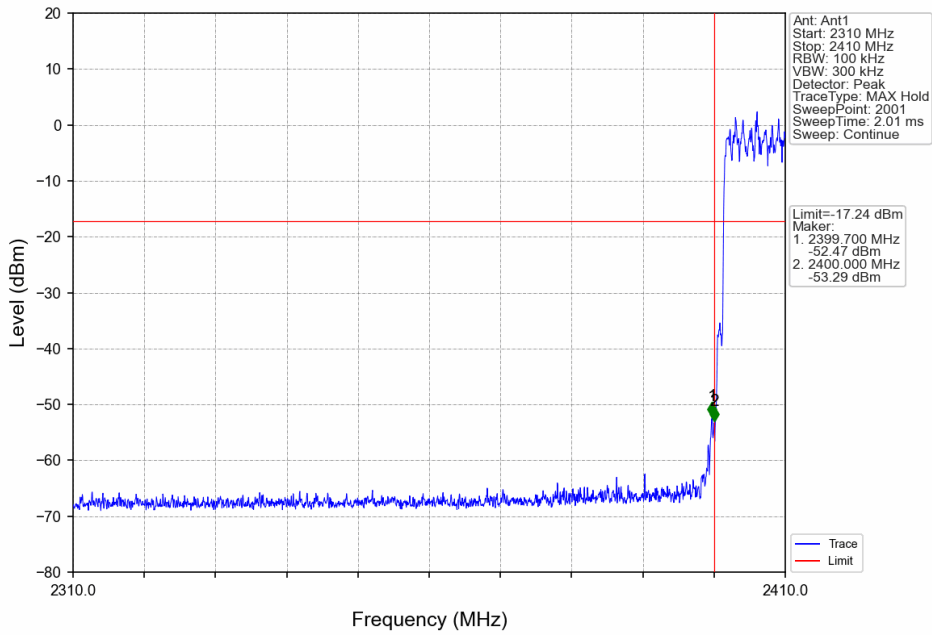

Pi/4DQPSK_2DH5_HOPP_Ant1_NTNV

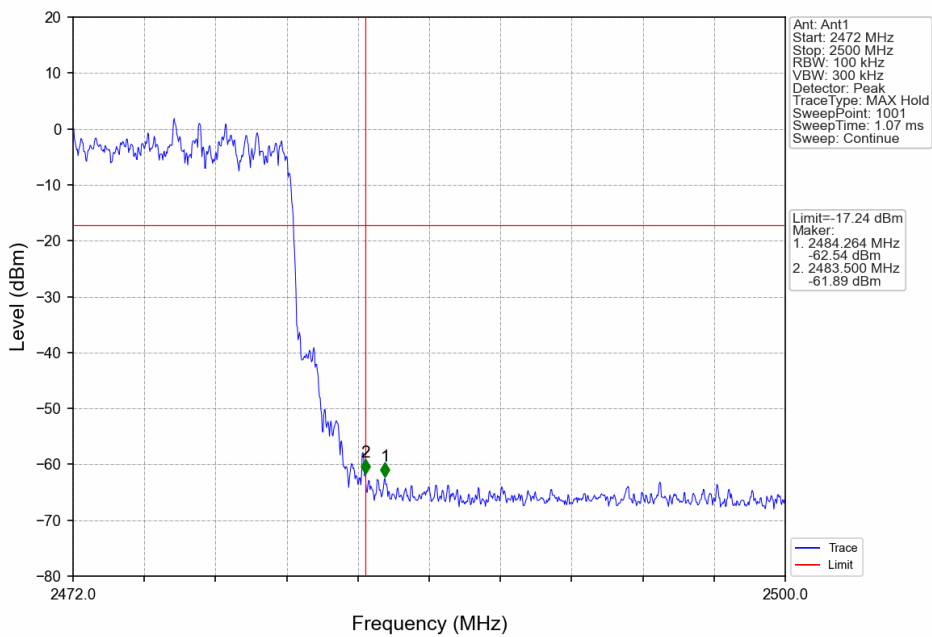

8DPSK_3DH5_LCH_2402MHz_Ant1_NTNV

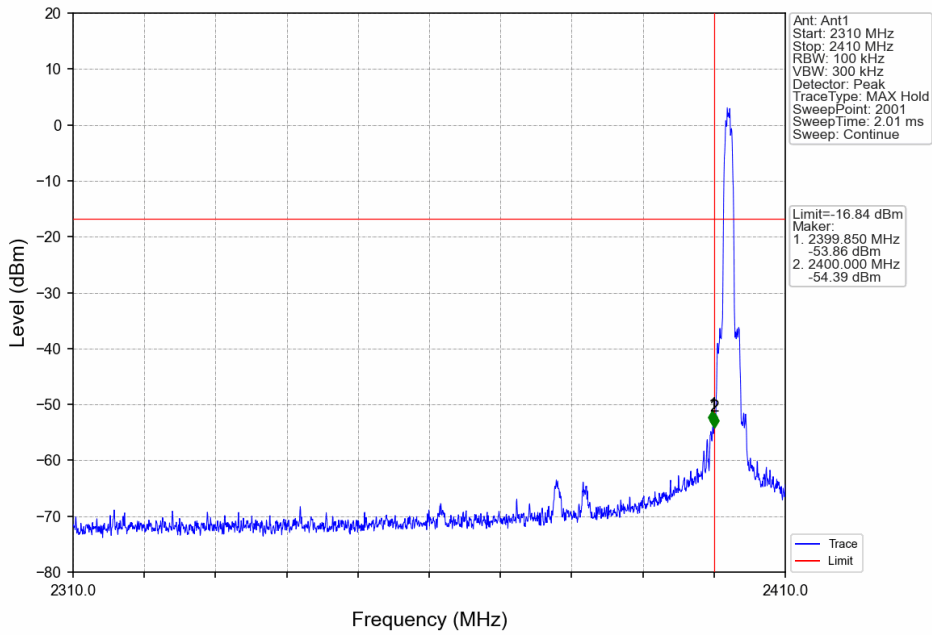

8DPSK_3DH5_HCH_2480MHz_Ant1_NTNV

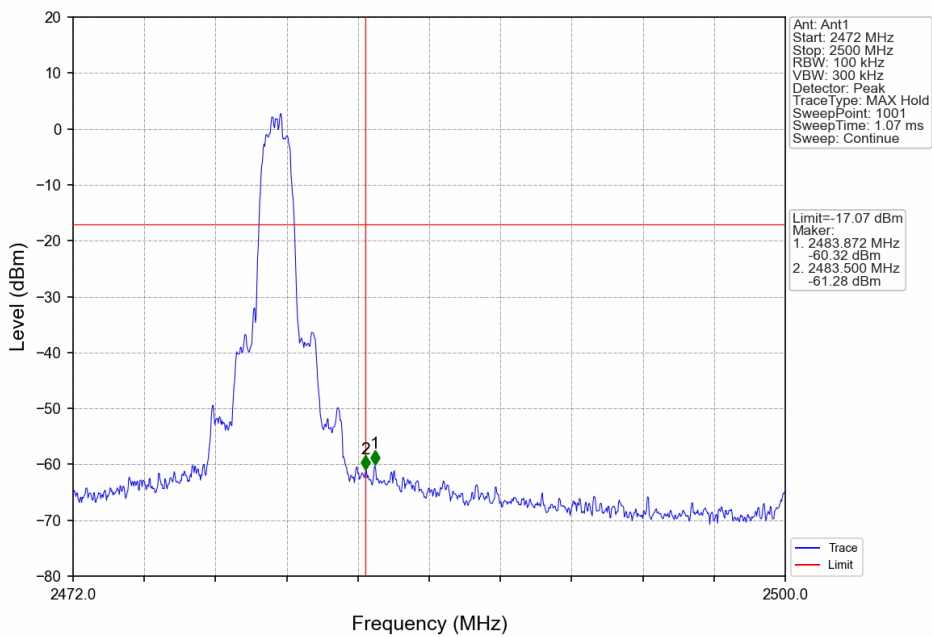

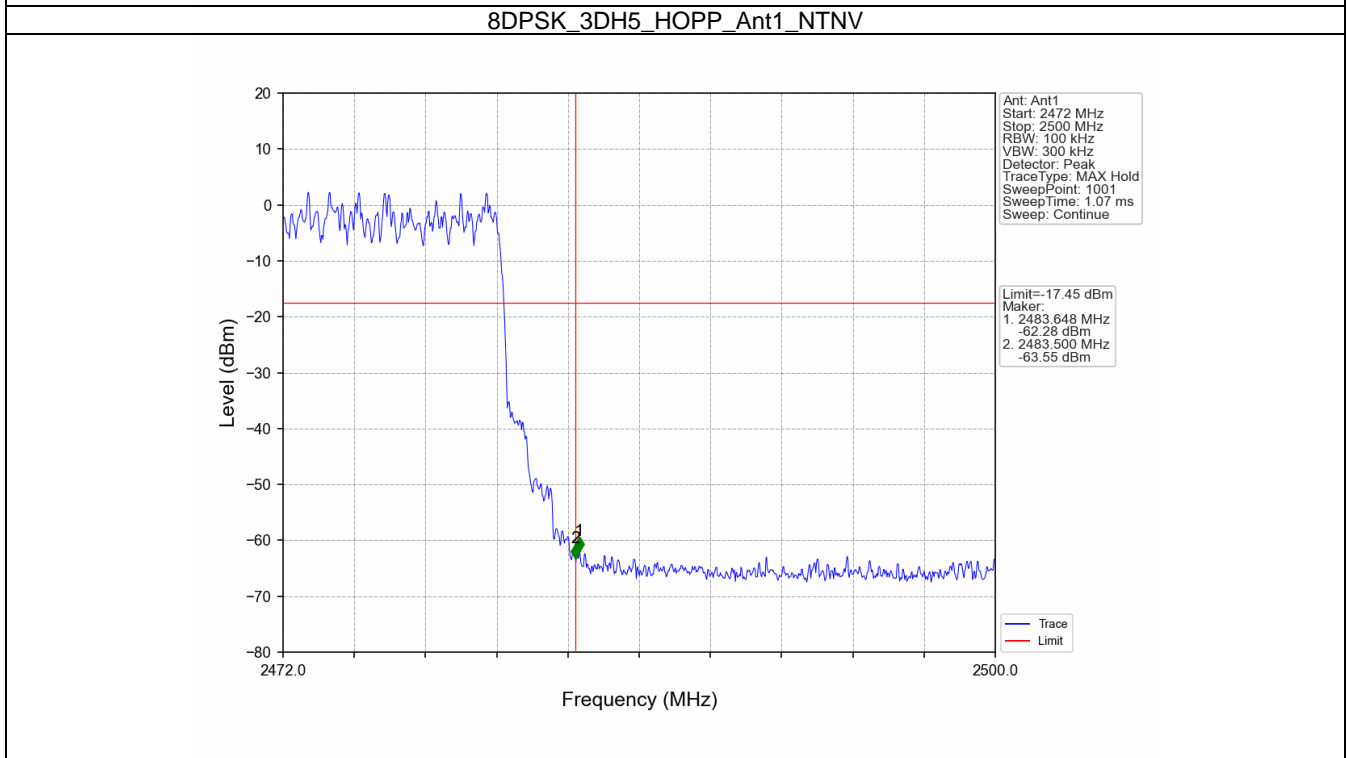
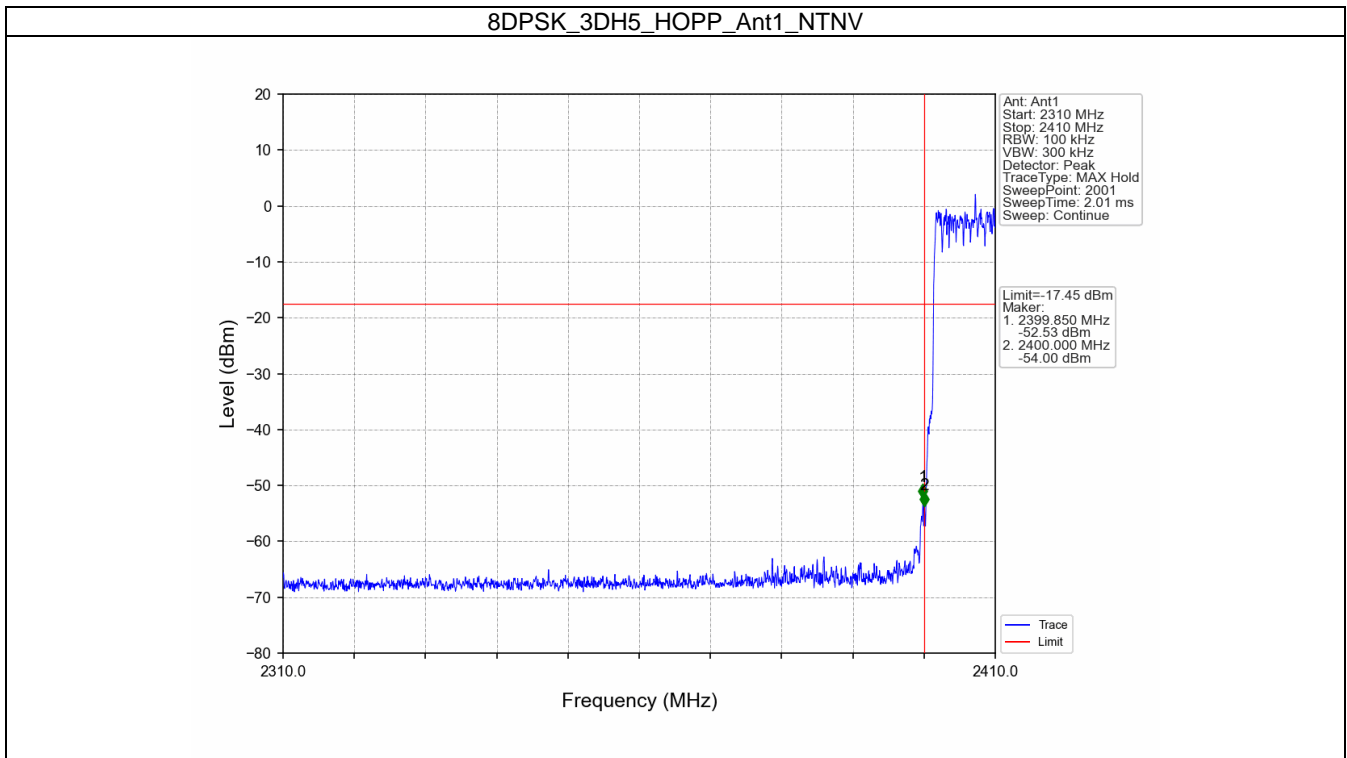

9.9 Spurious Radiated Emissions for Transmitter

Test Method

1. The EUT was placed on a turn table which is 1.5m above ground plane for above 1GHz and 0.8m above ground for below 1GHz at 3 meters chamber room for test. The table was rotated 360 degrees to determine the position of the highest radiation.
2. Set to the maximum power setting and enable the EUT transmit continuously
3. The EUT was set 3 meters away from the interference – receiving antenna, which was mounted on the top of a variable – height antenna tower.
4. The height of antenna is varied from one meter to four meters above the ground to determine the maximum value of the field strength. Both horizontal and vertical polarizations of the antenna are set to make the measurement.
5. For each suspected emission, the EUT was arranged to its worst case and then the antenna was tuned to heights from 1 meter to 4 meters and the rotatable table was turned from 0 degrees to 360 degrees to find the maximum reading.
6. Use the following test receiver settings According to C63.10:
 - (1) Span shall wide enough to fully capture the emission being measured;
 - (2) Set RBW=100 kHz to 120KHz for $f < 1$ GHz; $VBW \geq RBW$; Sweep = auto; Detector function = QP; Trace = max hold;
 - (3) Set RBW = 1 MHz, VBW= 3MHz for $f \geq 1$ GHz for peak measurement.

For average measurement:

The resolution bandwidth of test receiver/spectrum analyzer is 1MHz and the video bandwidth is 3MHz for RMS Average ((duty cycle < 98%) for Average detection (AV) at frequency above 1GHz, then the measurement results was added to a correction factor ($20\log(1/\text{duty cycle})$).

The resolution bandwidth of test receiver/spectrum analyzer is 1MHz and the video bandwidth is 10Hz (duty cycle > 98%) for Average detection (AV) at frequency above 1GHz.

7. Repeat above procedures until all frequencies measured were complete.

Spurious Radiated Emissions for Transmitter

Limit

The radio emission outside the operating frequency band shall be at least 20 dB below that in the 100 kHz bandwidth within the band that contains the highest level of the desired power. Radiated emissions which fall in the restricted bands, as defined in section 15.205 & RSS-GEN 8.10, must comply with the radiated emission limits specified in section 15.209 & RSS-Gen 6.13.

Frequency MHz	Field Strength $\mu\text{V/m}$	Field Strength $\text{dB}\mu\text{V/m}$	Detector	Measurement distance meters
0.009-0.490	2400/F(kHz)	48.5-13.8	AV	300
0.490-1.705	24000/F(kHz)	33.8-23.0	QP	30
1.705-30	30	29.5	QP	30
30-88	100	40	QP	3
88-216	150	43.5	QP	3
216-960	200	46	QP	3
960-1000	500	54	QP	3
Above 1000	500	54	AV	3
Above 1000	5000	74	PK	3

Note 1: $\text{Limit } 3\text{m}(\text{dB}\mu\text{V/m}) = \text{Limit } 300\text{m}(\text{dB}\mu\text{V/m}) + 40\text{Log}(300\text{m}/3\text{m})$ (Below 30MHz)

Note 2: $\text{Limit } 3\text{m}(\text{dB}\mu\text{V/m}) = \text{Limit } 30\text{m}(\text{dB}\mu\text{V/m}) + 40\text{Log}(30\text{m}/3\text{m})$ (Below 30MHz)

Spurious radiated emissions for transmitter

According to C63.10, if the peak (or quasi-peak) measured value complies with the average limit, it is unnecessary to perform an average measurement, so AV emission value did not show in below table if the peak value complies with average limit.

Only the worst case (8DPSK-3DH5) test result is listed in the report.

Transmitting spurious emission test result as below:

Emission below 1GHz

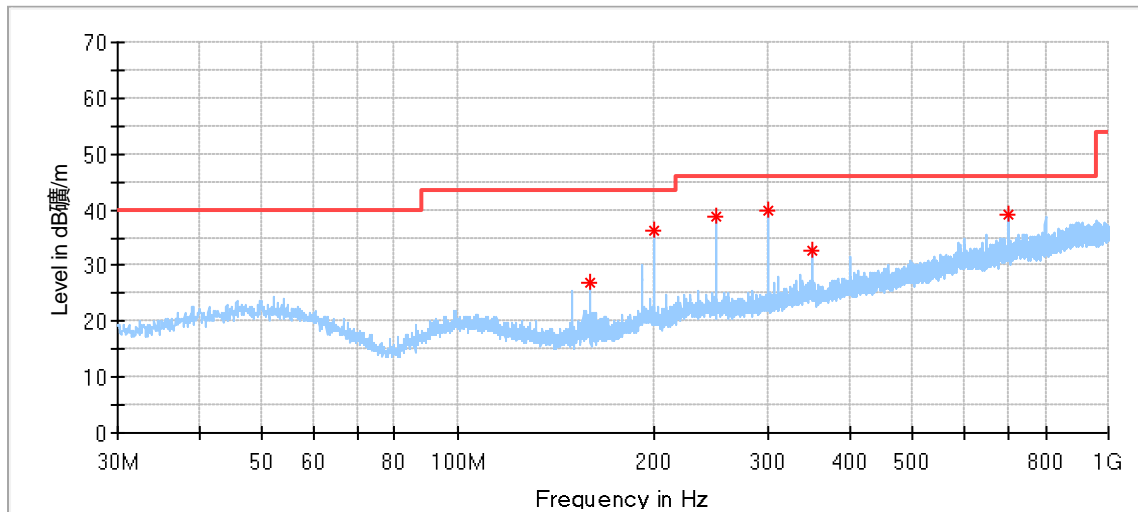

Critical_Freqs

Frequency (MHz)	MaxPeak (dBµV/m)	Limit (dBµV/m)	Margin (dB)	Height (cm)	Pol	Azimuth (deg)	Corr. (dB/m)
159.710556	27.04	43.50	16.46	100.0	H	247.0	13.13
199.965556	36.29	43.50	7.21	100.0	H	302.0	15.78
249.974444*	38.60	46.00	7.40	100.0	H	168.0	17.78
299.983333	39.74	46.00	6.26	100.0	H	105.0	18.48
350.046111	32.55	46.00	13.45	100.0	H	0.0	20.13
700.054444	39.13	46.00	6.87	100.0	H	129.0	26.31

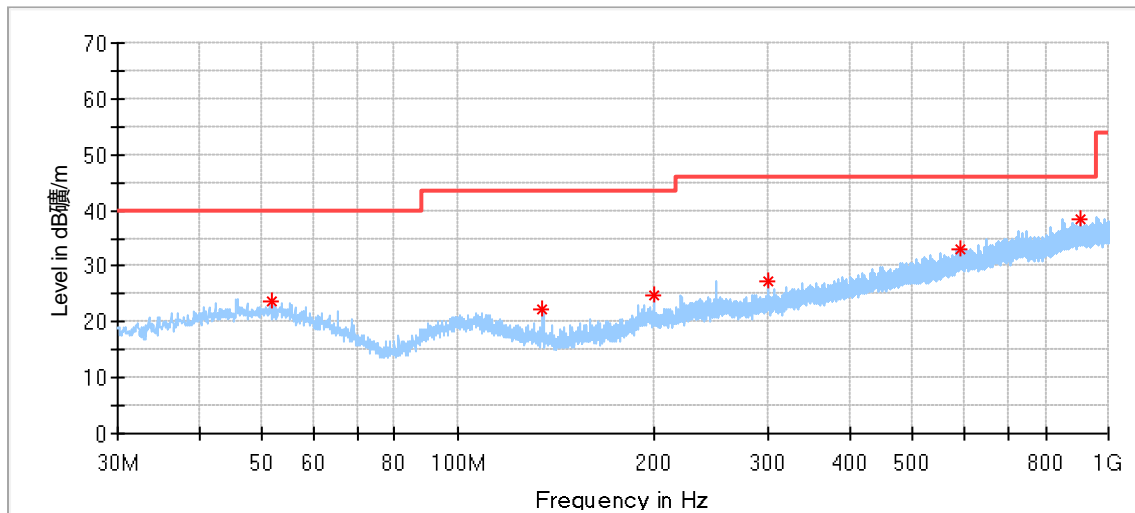

Critical Freqs

Frequency (MHz)	MaxPeak (dBμV/m)	Limit (dBμV/m)	Margin (dB)	Height (cm)	Pol	Azimuth (deg)	Corr. (dB/m)
51.878889	23.70	40.00	16.30	100.0	V	42.0	18.22
135.137222*	22.11	43.50	21.39	100.0	V	327.0	12.77
199.965556	24.92	43.50	18.58	100.0	V	350.0	15.78
299.929444	27.36	46.00	18.64	100.0	V	4.0	18.48
590.929444	33.05	46.00	12.95	100.0	V	34.0	24.95
907.311111	38.54	46.00	7.46	100.0	V	26.0	29.38

Emission above 1GHz

3DH5_Low Channel:

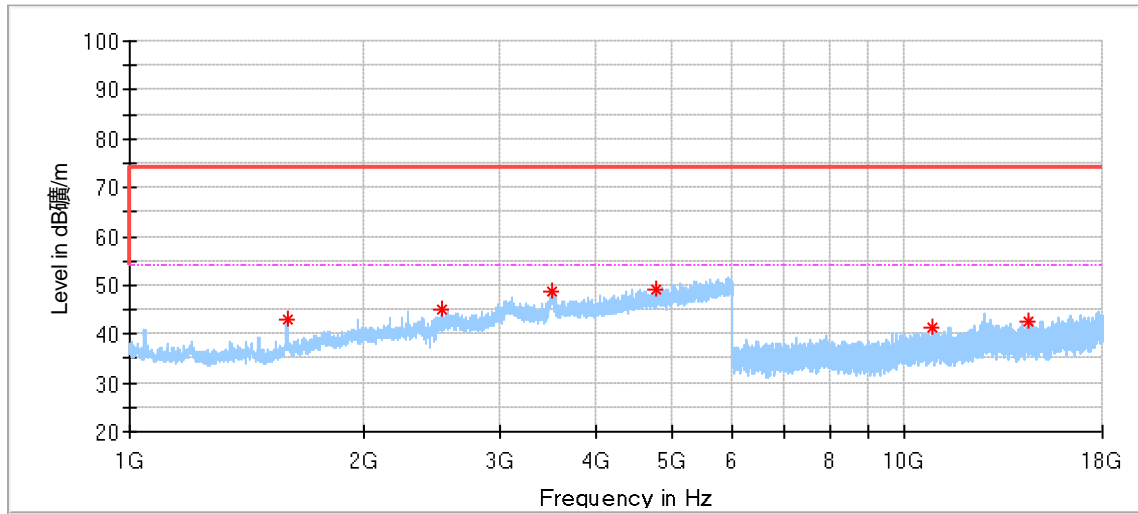

Critical_Freqs

Frequency (MHz)	MaxPeak (dBµV/m)	Limit (dBµV/m)	Margin (dB)	Height (cm)	Pol	Azimuth (deg)	Corr. (dB/m)
1595.000000*	42.93	74.00	31.07	150.0	H	57.0	-6.92
2521.500000	44.85	74.00	29.15	150.0	H	119.0	-1.70
3511.000000	48.63	74.00	25.37	150.0	H	160.0	3.93
4788.500000*	48.95	74.00	25.05	150.0	H	27.0	4.84
10872.000000*	41.14	74.00	32.86	150.0	H	132.0	10.80
14469.000000	42.40	74.00	31.60	150.0	H	333.0	13.38

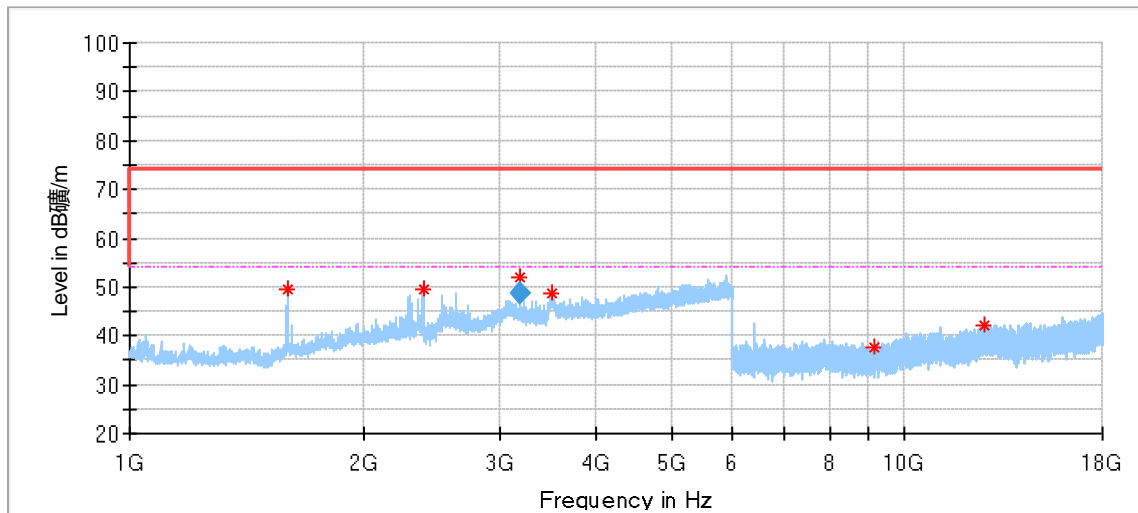

Critical Freqs

Frequency (MHz)	MaxPeak (dBµV/m)	Limit (dBµV/m)	Margin (dB)	Height (cm)	Pol	Azimuth (deg)	Corr. (dB/m)
1600.500000*	49.48	74.00	24.52	150.0	V	132.0	-6.84
2391.500000	49.74	74.00	24.26	150.0	V	173.0	-2.43
3191.500000	51.88	74.00	22.12	150.0	V	162.0	0.63
3509.500000	48.62	74.00	25.38	150.0	V	275.0	4.01
9110.500000*	37.59	74.00	36.41	150.0	V	250.0	8.02
12680.500000*	41.96	74.00	32.04	150.0	V	49.0	12.78

Final Result

Frequency (MHz)	Average (dBµV/m)	Limit (dBµV/m)	Margin (dB)	Height (cm)	Pol	Azimuth (deg)	Corr. (dB/m)
3191.500000	48.70	54.00	5.30	150.0	V	162.0	0.63

3DH5_Middle Channel:

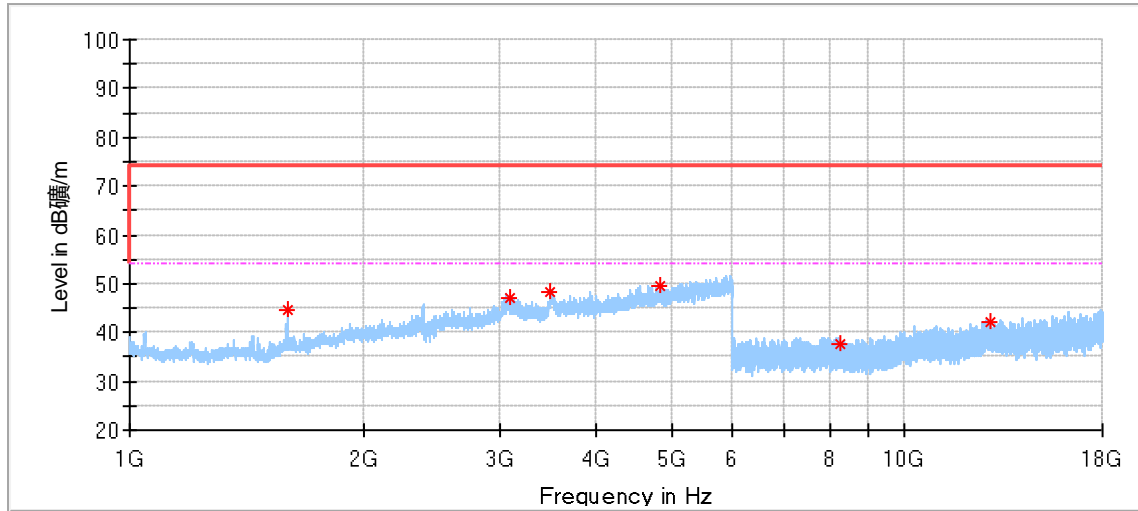

Critical_Freqs

Frequency (MHz)	MaxPeak (dBμV/m)	Limit (dBμV/m)	Margin (dB)	Height (cm)	Pol	Azimuth (deg)	Corr. (dB/m)
1596.500000*	44.65	74.00	29.35	150.0	H	57.0	-6.89
3090.000000	47.14	74.00	26.86	150.0	H	234.0	1.59
3490.500000	48.37	74.00	25.63	150.0	H	183.0	3.76
4831.500000*	49.36	74.00	24.64	150.0	H	111.0	5.05
8237.500000*	37.60	74.00	36.40	150.0	H	27.0	7.45
12907.500000	42.28	74.00	31.72	150.0	H	27.0	12.94

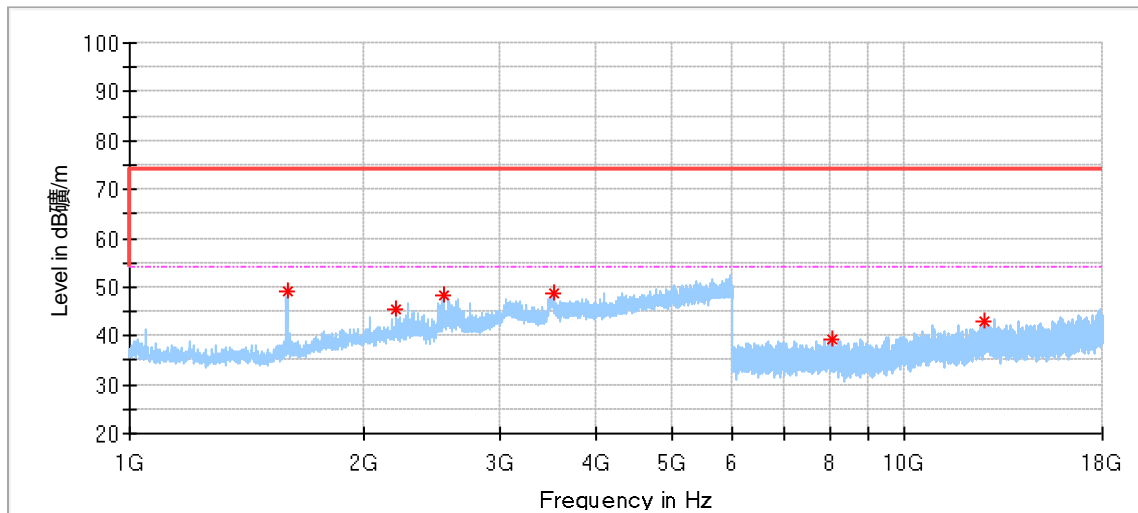

Critical Freqs

Frequency (MHz)	MaxPeak (dBµV/m)	Limit (dBµV/m)	Margin (dB)	Height (cm)	Pol	Azimuth (deg)	Corr. (dB/m)
1597.000000*	49.17	74.00	24.83	150.0	V	91.0	-6.88
2208.500000*	45.60	74.00	28.40	150.0	V	101.0	-3.57
2538.000000	48.24	74.00	25.76	150.0	V	111.0	-1.50
3519.500000	48.76	74.00	25.24	150.0	V	121.0	3.50
8045.000000*	39.23	74.00	34.77	150.0	V	72.0	7.49
12637.000000*	42.79	74.00	31.21	150.0	V	212.0	12.73

3DH5_Hight Channel:

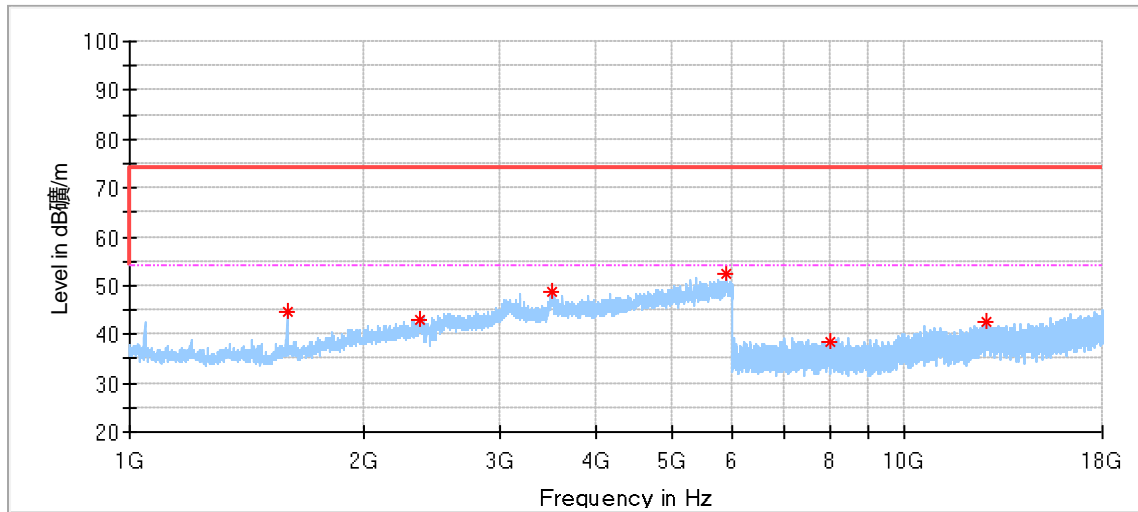

Critical_Freqs

Frequency (MHz)	MaxPeak (dBµV/m)	Limit (dBµV/m)	Margin (dB)	Height (cm)	Pol	Azimuth (deg)	Corr. (dB/m)
1595.000000*	44.57	74.00	29.43	150.0	H	80.0	-6.92
2363.500000*	43.10	74.00	30.90	150.0	H	224.0	-2.69
3500.000000	48.63	74.00	25.37	150.0	H	265.0	4.48
5871.000000	52.23	74.00	21.77	150.0	H	203.0	8.01
7999.000000	38.43	74.00	35.57	150.0	H	132.0	7.46
12757.000000	42.56	74.00	31.44	150.0	H	330.0	12.92

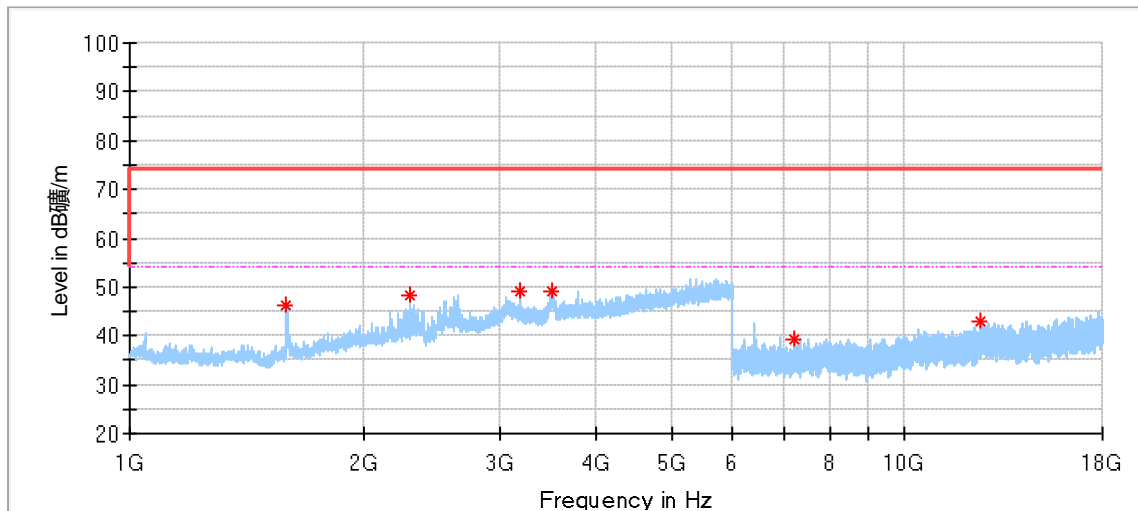

Critical Freqs

Frequency (MHz)	MaxPeak (dBμV/m)	Limit (dBμV/m)	Margin (dB)	Height (cm)	Pol	Azimuth (deg)	Corr. (dB/m)
1593.500000*	46.09	74.00	27.91	150.0	V	203.0	-6.94
2297.500000*	48.24	74.00	25.76	150.0	V	91.0	-3.28
3187.000000	49.13	74.00	24.87	150.0	V	91.0	0.65
3506.000000	48.99	74.00	25.01	150.0	V	162.0	4.19
7193.000000	39.46	74.00	34.54	150.0	V	173.0	6.35
12541.500000*	42.94	74.00	31.06	150.0	V	92.0	12.52

Remark:

- (1) "*" means the emission(s) appear within the restrict bands shall follow the requirement of § 15.205 and RSS-Gen section 8.10.
- (2) Data of measurement within frequency ranges 9kHz-30MHz and 18-26GHz are the noise floor or attenuated more than 20dB below the permissible limits or the field strength is too small to be measured, so test data does not present in this report,
- (3) Level= Reading Level + Correction Factor
- (4) Above 1GHz: Corrector factor = Antenna Factor + Cable Loss- Amplifier Gain
Below 1GHz: Corrector factor = Antenna Factor + Cable Loss
(The Reading Level is recorded by software which is not shown in the sheet)

10 Test Equipment List

Conducted Emission Test

Description	Manufacturer	Model no.	Equipment ID	Serial no.	Cal interval (year)	Cal. due date
EMI Test Receiver	Rohde & Schwarz	ESR 3	68-4-74-19-002	102590	1	2024-5-19
LISN	Rohde & Schwarz	ENV216	68-4-87-19-001	102472	1	2024-5-20
Attenuator	Shanghai Huaxiang	TS2-26-3	68-4-81-16-003	080928189	1	2024-5-19
Test software	Rohde & Schwarz	EMC32	68-4-90-19-005-A01	Version 10.35.02	N/A	N/A
Shielding Room	TDK	CSR #2	68-4-90-19-005	----	3	2025-10-15

Radiated Emission Test, SAC-3 #1

Description	Manufacturer	Model no.	Equipment ID	Serial no.	Cal interval (year)	Cal. due date
EMI Test Receiver	Rohde & Schwarz	ESR 7	68-4-74-19-001	102176	1	2024-5-20
Loop Antenna	Rohde & Schwarz	HFH2-Z2	68-4-80-14-006	100398	1	2024-8-7
Pre-amplifier	Rohde & Schwarz	SCU 18	68-4-29-14-001	102230	1	2024-5-19
Attenuator	Mini-circuits	UNAT-6+	68-4-81-21-001	15542	1	2024-5-19
3m Semi-anechoic chamber	TDK	SAC-3 #1	68-4-90-14-001	----	3	2024-5-28
Test software	Rohde & Schwarz	EMC32	68-4-90-14-001-A10	Version10.35.02	N/A	N/A

Radiated Emission Test, SAC-3 #2

Description	Manufacturer	Model no.	Equipment ID	Serial no.	Cal interval (year)	Cal. due date
EMI Test Receiver	Rohde & Schwarz	ESR 26	68-4-74-14-002	101269	1	2024-5-20
Trilog Super Broadband Test Antenna	Schwarzbeck	VULB 9162	68-4-80-19-003	284	1	2024-3-5
Wave Guide Antenna	ETS	3117	68-4-80-19-001	00218954	1	2024-4-26
Pre-amplifier	Rohde & Schwarz	SCU 18F	68-4-29-19-001	100745	1	2024-5-19
Pre-amplifier	Rohde & Schwarz	SCU 18F	68-4-29-19-002	100746	1	2024-5-19
Sideband Horn Antenna	Q-PAR	QWH-SL-18-40-K-SG	68-4-80-14-008	12827	1	2024-7-11
Pre-amplifier	Rohde & Schwarz	SCU 40A	68-4-29-14-002	100432	1	2024-8-1
Attenuator	Mini-circuits	UNAT-6+	68-4-81-21-002	15542	1	2024-5-19
3m Semi-anechoic chamber	TDK	SAC-3 #2	68-4-90-19-006	----	2	2024-5-28
Test software	Rohde & Schwarz	EMC32	68-4-90-19-006-A01	Version10.35.02	N/A	N/A

RF Conducted Test

Description	Manufacturer	Model no.	Equipment ID	Serial no.	Cal interval (year)	Cal. due date
Signal Analyzer	Rohde & Schwarz	FSV40	68-4-74-14-004	101030	1	2024-5-19
Test software	Tonscend	System for BT/WIFI	68-4-74-14-006-A13	Version 2.6.77.0518	N/A	N/A

11 System Measurement Uncertainty

For a 95% confidence level, the measurement expanded uncertainties for defined systems, in accordance with the recommendations of ISO 17025 were:

System Measurement Uncertainty	
Test Items	Extended Uncertainty
Uncertainty for Conducted Emission in new shielding room (68-4-90-19-005) 150kHz-30MHz (for test using AMN ENV216)	3.33dB
Uncertainty for Radiated Emission in 3m chamber (68-4-90-14-001) 9kHz-30MHz	4.70dB
Uncertainty for Radiated Emission in new 3m chamber (68-4-90-19-006) 30MHz-1000MHz	Horizontal: 4.59dB; Vertical: 4.75dB
Uncertainty for Radiated Emission in new 3m chamber (68-4-90-19-006) 1000MHz-18000MHz	Horizontal: 5.08dB; Vertical: 5.09dB
Uncertainty for Radiated Emission in new 3m chamber (68-4-90-19-006) above 18000MHz	Horizontal: 3.14dB; Vertical: 3.12dB
Uncertainty for Conducted RF test with TS 8997	RF Power Conducted: 1.31dB Frequency test involved: 0.6×10 ⁻⁸ or 1%

Measurement Uncertainty Decision Rule:

Determination of conformity with the specification limits is based on the decision rule according to IEC Guide 115:2021, clause 4.4.3 and 4.5.1.

---END OF REPORT---