

FCC &ISED Radio Test Report**FCC ID: 2AC23-DCT2W
IC: 12290A- DCT2W****The report concerns: Original Grant**

Report Reference No.....: 21EFSS08091 07671
 Date Sample(s) Received.....: 2021-08-20
 Date of Tested.....: 2021-08-20 to 2021-09-10
 Date of issue.....: 2021-09-10
 Testing Laboratory: DongGuanShuoXin Electronic Technology Co., Ltd.
 Zone A, 1F, No. 6, XinGang Road YuanGang Street,
 Address: XinAn District, ChangAn Town, DongGuan City,
 GuangDong, China

 Applicant's name: Hui Zhou Gaoshengda Technology Co., LTD
 Address: NO.75 Zhongkai Development Area, Huizhou,
 Guangdong,China
 Manufacturer.....: Hui Zhou Gaoshengda Technology Co., LTD

 Equipment.....: WIFI+BT Module
 Trade Mark: GSD
 Model: DCT2WM2611
 Ratings: I/P: DC 5V

Test Engineer:



Blue Qiu

Responsible Engineer :



Smile Wang

Authorized Signatory:

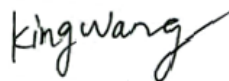

King Wang

Table of Contents	Page
1 . TEST REPORT DECLARE	4
2 . SUMMARY OF TEST RESULTS	5
2.1 MEASUREMENT UNCERTAINTY	6
3 . GENERAL INFORMATION	7
3.1 GENERAL DESCRIPTION OF EUT	7
3.2 DESCRIPTION OF TEST MODES	8
3.3 PARAMETERS OF TEST SOFTWARE	9
3.4 BLOCK DIAGRAM SHOWING THE CONFIGURATION OF SYSTEM TESTED	10
3.5 SUPPORT UNITS	10
3.6 TEST ENVIRONMENT CONDITIONS	10
3.7 DUTY CYCLE	11
4 . AC POWER LINE CONDUCTED EMISSIONS TEST	12
4.1 LIMIT	12
4.2 TEST PROCEDURE	12
4.3 MEASUREMENT INSTRUMENTS LIST	12
4.4 TEST SETUP	13
4.5 EUT OPERATION CONDITIONS	13
4.6 TEST RESULTS	14
5 . RADIATED EMISSIONS TEST	16
5.1 LIMIT	16
5.2 TEST PROCEDURE	17
5.3 MEASUREMENT INSTRUMENTS LIST	18
5.4 TEST SETUP	18
5.5 EUT OPERATION CONDITIONS	19
5.6 TEST RESULTS - 9KHZ TO 30MHZ	20
5.7 TEST RESULTS - 30MHZ TO 1000MHZ	21
5.8 TEST RESULTS- ABOVE 1000MHZ(BAND EDGE)	23
5.9 TEST RESULTS- ABOVE 1000MHZ(HARMONIC)	39
6 . BANDWIDTH TEST	63
6.1 LIMIT	63
6.2 TEST PROCEDURE AND SETTING	63
6.3 MEASUREMENT INSTRUMENTS LIST	63
6.4 TEST SETUP	63

Table of Contents	Page
6.5EUT OPERATION CONDITIONS	63
6.6TESTRESULTS	64
7 .MAXIMUM OUTPUT POWER TEST	68
7.1LIMIT	68
7.2TEST PROCEDURE AND SETTING	68
7.3MEASUREMENT INSTRUMENTS LIST	68
7.4TEST SETUP	68
7.5EUT OPERATION CONDITIONS	68
7.6TESTRESULTS	69
8 .CONDUCTED SPURIOUS EMISSIONS	73
8.1 LIMIT	73
8.2TEST PROCEDURE AND SETTING	73
8.3MEASUREMENT INSTRUMENTS LIST	73
8.4TEST SETUP	73
8.5EUT OPERATION CONDITIONS	73
8.6TESTRESULTS	74
9 .POWER SPECTRAL DENSITY TEST	80
9.1LIMIT	80
9.2TEST PROCEDURE AND SETTING	80
9.3MEASUREMENT INSTRUMENTS LIST	80
9.4TEST SETUP	80
9.5EUT OPERATION CONDITIONS	80
9.6TESTRESULTS	81
10 .FREQUENCY STABILITY MEASUREMENT	84
10.1LIMIT	84
10.2TEST PROCEDURE AND SETTING	84
10.3MEASUREMENT INSTRUMENTS LIST	84
10.4TEST SETUP	84
10.5EUT OPERATION CONDITIONS	84
10.6 TEST RESULTS	85

1TEST REPORT DECLARE

Applicant	Hui Zhou Gaoshengda Technology Co., LTD
Address	NO.75 Zhongkai Development Area, Huizhou, Guangdong, China
Manufacturer	Hui Zhou Gaoshengda Technology Co., LTD
Address	No.2,Jin-da Road, Huinan High-tech Industrial Park, Hui-ao Avenue, Huizhou City, Guangdong, China
Factory	Hui Zhou Gaoshengda Technology Co., LTD
Address	No.2,Jin-da Road, Huinan High-tech Industrial Park, Hui-ao Avenue, Huizhou City, Guangdong, China
Equipment	WIFI+BT Module
Model No.	DCT2WM2611
Trade Mark	GSD
Standard	FCC Part15, Subpart C (15.247) RSS-247 Issue 2, Feb. 2017 RSS-Gen Issue 5, Apr. 2018 ANSI C63.10-2013

We Declare:

The equipment described above is tested by DongGuan ShuoXin Electronic Technology Co., Ltd(ATT). and in the configuration tested the equipment complied with the standards specified above. The test results are contained in this test report and DongGuan ShuoXin Electronic Technology Co., Ltd.(ATT) is assumed of full responsibility for the accuracy and completeness of these tests.

ATT is not responsible for the sampling stage, so the results only apply to the sample as received.

ATT's reports apply only to the specific samples tested under conditions. It is manufacture's responsibility to ensure that additional production units of this model are manufactured with the identical electrical and mechanical components. ATT shall have no liability for any declarations, inferences or generalizations drawn by the client or others from ATT issued reports.

2444 SUMMARY OF TEST RESULTS

The EUT have been tested according to the applicable standards as referenced below:

Standard(s) Section		Test Item	Judgment	Remark
FCC	ISED			
15.207	RSS-Gen8.8	AC Power Line Conducted Emissions	PASS	-----
15.247(d) 15.205(a) 15.209(a)	RSS-247 5.5 RSS-Gen8.9 RSS-Gen8.10	Radiated Emissions	PASS	-----
15.247(a)(2)	RSS-247 5.2 (a) RSS-Gen6.7	Bandwidth	PASS	-----
15.247(b)(3)	RSS-247 5.4 (d)	Maximum Output Power	PASS	-----
15.247(d)	RSS-247 5.5	ConductedSpurious Emission	PASS	-----
15.247(e)	RSS-247 5.2 (b)	Power Spectral Density	PASS	-----
-	RSS-Gen 6.11	Frequency Stability	PASS	-----
15.203	-	Antenna Requirement	PASS	Note(2)

Note:

- (1) "N/A" denotes test is not applicable in this test report.
- (2) The device what use a permanently attached antenna were considered sufficient tocomply with the provisions of 15.203.

2.1 MEASUREMENT UNCERTAINTY

Test Item	Uncertainty
Uncertainty for Conduction emission test (9kHz-150kHz)	3.7 dB
Uncertainty for Conduction emission test (150kHz-30MHz)	3.3 dB
Uncertainty for Radiation Emission test (30MHz-200MHz)	4.60 dB (Polarize: V)
	4.60 dB (Polarize: H)
Uncertainty for Radiation Emission test (200MHz-1GHz)	6.10 dB (Polarize: V)
	5.08 dB (Polarize: H)
Uncertainty for Radiation Emission test (1GHz-6GHz)	5.01 dB (Polarize: V)
	5.01 dB (Polarize: H)
Uncertainty for Radiation Emission test (6GHz-18GHz)	5.26 dB (Polarize: V)
	5.26 dB (Polarize: H)
Uncertainty for Radiation Emission test (18GHz-40GHz)	5.06 dB (Polarize: V)
	5.06 dB (Polarize: H)
Uncertainty for radio frequency	±0.048kHz
Uncertainty for conducted RF Power	±0.32dB

Note:

This uncertainty represents an expanded uncertainty expressed at approximately the 95% confidence level using a coverage factor of k=2.

Test Facility:

The Test site used by DongGuan ShuoXin Electronic Technology Co., Ltd. to collect test data is located on the Zone A, 1F, No. 6, XinGang Road YuanGang Street, XinAn District, ChangAn Town, DongGuan City, GuangDong, China

The test facility is recognized, certified, or accredited by the following organizations:

Item	Registration No.	Expiration Date
CNAS	L3098	2024-08-27
A2LA	4893.01	2022-06-30
Innovation, Science and Economic Development Canada (ISED)	11033A CAB identifier:CN0083	2022-06-30
Federal Communications Commission (FCC)	171688 Designation No.:CN1235	2022-06-30

3 GENERAL INFORMATION

3.1 GENERAL DESCRIPTION OF EUT

Equipment	WIFI+BT Module		
Brand Name	GSD		
Test Model	DCT2WM2611		
Series Model	N/A		
Model Difference(s)	N/A		
Hardware Version	V1.0		
Software Version	V1.0		
PowerSource	Supplied from USB.		
Power Rating	DC 5V		
Operation Frequency	2412 MHz~ 2462 MHz		
Modulation Technology	IEEE 802.11b:DSSS IEEE 802.11g:OFDM IEEE 802.11n:OFDM		
Bit Rate of Transmitter	IEEE 802.11b: 11/5.5/2/1 Mbps IEEE 802.11g: 54/48/36/24/18/12/9/6 Mbps IEEE 802.11n: up to 300 Mbps		
Operating Mode	IEEE 802.11b:1TX(Ant 1 or Ant 2) IEEE 802.11g:1TX(Ant 1 or Ant 2) IEEE 802.11n (HT20):2TX(Ant 1+Ant 2) IEEE 802.11n (HT40):2TX(Ant 1+Ant 2)		
Antenna Information	Antenna Type:PCB	Maximum Peak Gain:3dBi	
Max. Output Power	IEEE 802.11b: 17.50dBm(0.0562W) IEEE 802.11g: 20.99dBm(0.1256W) IEEE 802.11n (HT20):23.03dBm(0.1872W) IEEE 802.11n (HT40):23.26dBm(0.2117W)		

Note:

- For a more detailed features description, please refer to the manufacturer's specifications or the user's manual.
- Channel List:

CH01 - CH11 for IEEE 802.11b, IEEE 802.11g, IEEE 802.11n (HT20) CH03-CH09 for IEEE 802.11n (HT40)							
Channel	Frequency (MHz)	Channel	Frequency (MHz)	Channel	Frequency (MHz)	Channel	Frequency (MHz)
01	2412	04	2427	07	2442	10	2457
02	2417	05	2432	08	2447	11	2462
03	2422	06	2437	09	2452		

3.2 DESCRIPTION OF TEST MODES

The test system was pre-tested based on the consideration of all possible combinations of EUT operation mode.

Pretest Mode	Description
Mode 1	TX B Mode Channel 01/06/11
Mode 2	TX G Mode Channel 01/06/11
Mode 3	TX N-20 MHz Mode Channel 01/06/11
Mode 4	TX N-40 MHz Mode Channel03/06/09
Mode 5	TX N-40 MHz Mode Channel 03

Following mode(s) as (were) found to be the worst case(s) and selected for the final test.

AC power line conducted emissions test	
Final Test Mode	Description
Mode 5	TX N-40 MHz Mode Channel 03

Radiated emissions test - Below 1GHz	
Final Test Mode	Description
Mode 5	TX N-40 MHz Mode Channel 03

Radiated emissions test- Above 1GHz	
Final Test Mode	Description
Mode 1	TX B Mode Channel 01/06/11
Mode 2	TX G Mode Channel 01/06/11
Mode 3	TX N-20 MHz Mode Channel 01/06/11
Mode 4	TX N-40 MHz Mode Channel03/06/09

Conducted test	
Final Test Mode	Description
Mode 1	TX B Mode Channel 01/06/11
Mode 2	TX G Mode Channel 01/06/11
Mode 3	TX N-20 MHz Mode Channel 01/06/11
Mode 4	TX N-40 MHz Mode Channel03/06/09

NOTE:

(1) The measurements are performed at the high, middle, low available channels.

(2) 802.11b mode: DBPSK (1Mbps)

802.11g mode: OFDM (6Mbps)

802.11n HT20 mode : BPSK (13Mbps)

802.11n HT40mode : BPSK (27Mbps)

For radiated emission tests, the highest output powers were set for final test.

(3) For radiated emission below 1GHz and AC power line conducted emissions test, the IEEE 802.11n20 channel 11 is found to be the worst case and recorded.

3.3 PARAMETERS OF TEST SOFTWARE

Test Software	MT7663QA		
Frequency (MHz)	2412	2437	2462
IEEE 802.11b	1E	1E	19
IEEE 802.11g	20	20	20
IEEE 802.11n (HT20)	20	20	20
Test Frequency (MHz)	2422	2437	2452
IEEE 802.11n (HT40)	22	22	22

3.4 BLOCK DIAGRAM SHOWING THE CONFIGURATION OF SYSTEM TESTED

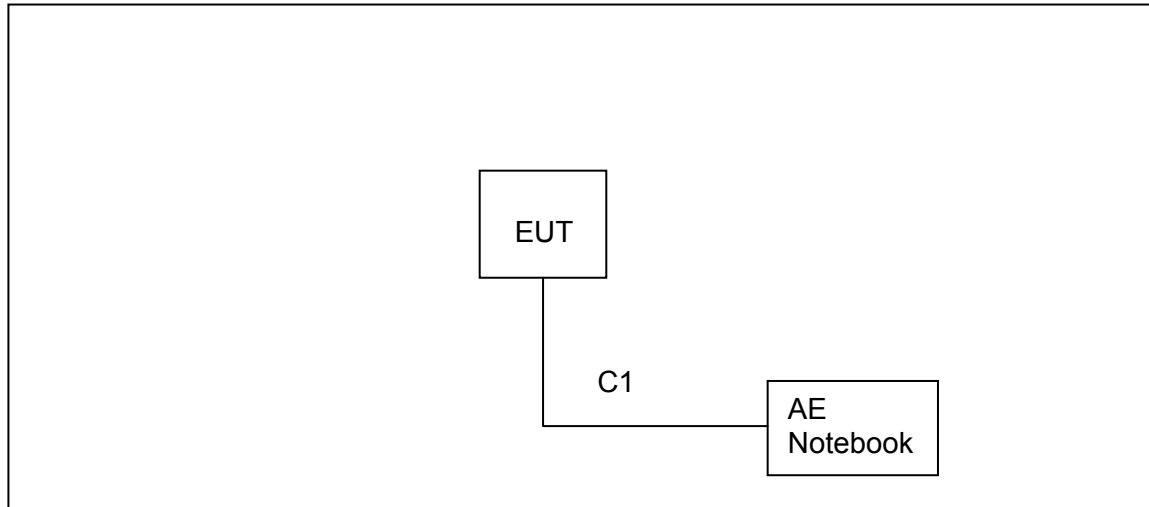

3.5 SUPPORT UNITS

Item	Equipment	Brand	Model No.	Series No.
AE	Notebook	Lenovo	/	/

Item	Cable Type	Shielded Type	Ferrite Core	Length
C1	DC Cable	NO	NO	0.8m

3.6 TEST ENVIRONMENT CONDITIONS

Test Item	Temperature	Humidity	Test Voltage
AC Power Line Conducted Emissions	25°C	53%	DC 5V
Radiated Emissions-9K-30MHz	25°C	60%	DC 5V
Radiated Emissions-30 MHz to 1GHz	24°C	68%	DC 5V
Radiated Emissions-Above 1000 MHz	24°C	68%	DC 5V
Bandwidth	24.8°C	40.9%	DC 5V
Maximum Output Power	24.8°C	40.9%	DC 5V
Conducted Spurious Emission	24.8°C	40.9%	DC 5V
Power Spectral Density	24.8°C	40.9%	DC 5V

3.7DUTY CYCLE

All tests were performed under the condition of 100% Duty Cycle

NOTE:

For IEEE 802.11a,IEEE 802.11n (HT20)

For radiated emissions frequency above 1 GHz, the resolution bandwidth of test receiver/spectrum analyzer is 1 MHz and the video bandwidth is 1 kHz (Duty cycle < 98%).

For IEEE 802.11n (HT40)

For radiated emissions frequency above 1 GHz, the resolution bandwidth of test receiver/spectrum analyzer is 1 MHz and the video bandwidth is 2 kHz (Duty cycle < 98%).

4AC POWER LINE CONDUCTED EMISSIONS TEST

4.1LIMIT

Frequency of Emission (MHz)	Limit (dB μ V)	
	Quasi-peak	Average
0.15 -0.50	66to 56*	56 to 46*
0.50 -5.0	56	46
5.0 -30.0	60	50

NOTE:

- (1) The tighter limit applies at the band edges.
- (2) The limit of " * " marked band means the limitation decreases linearly with the logarithm of the frequency in the range.

The following table is the setting of the receiver

Receiver Parameters	Setting
Attenuation	10 dB
Start Frequency	0.15 MHz
Stop Frequency	30 MHz
IF Bandwidth	9 kHz

4.2TEST PROCEDURE

- a. The EUT was placed 0.8 meters from the horizontal ground plane with EUT being connected to the power mains through a line impedance stabilization network (LISN). All other support equipment powered from additional LISN(s). The LISN provide 50 Ohm/ 50uH of coupling impedance for the measuring instrument.
- b. Interconnecting cables that hang closer than 40 cm to the ground plane shall be folded back and forth in the center forming a bundle 30 to 40 cm long.
- c. I/O cables that are not connected to a peripheral shall be bundled in the center. The end of the cable may be terminated, if required, using the correct terminating impedance. The overall length shall not exceed 1 m.
- d. LISN at least 80 cm from nearest part of EUT chassis.

4.3MEASUREMENT INSTRUMENTS LIST

Item	Kind of Equipment	Manufacturer	Type No.	Serial No.	Calibrated until
1	Pulse Limiter	MTS-systemtechnik	MTS-IMP-136	261115-010-0024	12/11/2021
2	EMI Test Receiver	R&S	ESCI	101308	12/12/2021
3	LISN	AFJ	LS16	16011103219	06/09/2022
4	LISN	Schwarzbeck	NSLK 8127	8127-432	12/11/2021
5	Measurement Software	Farad	EZ-EMC (Ver.ATT-03A)	N/A	N/A

4.4 TEST SETUP

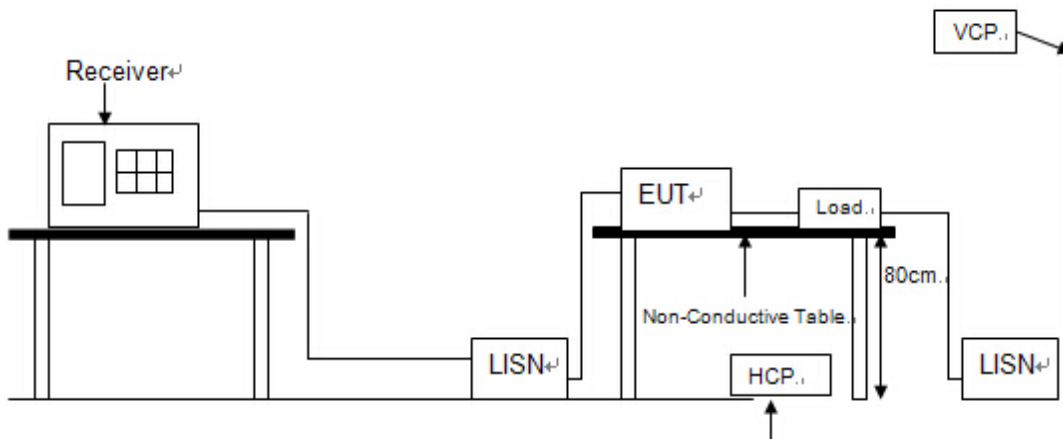

4.5 EUT OPERATION CONDITIONS

The EUT was configured for testing in a typical fashion (as a customer would normally use it). The EUT has been programmed to continuously transmit during test. This operating condition was tested and used to collect the included data.

4.6 TEST RESULTS

Test Mode: TX N-40 MHz Mode Channel 03

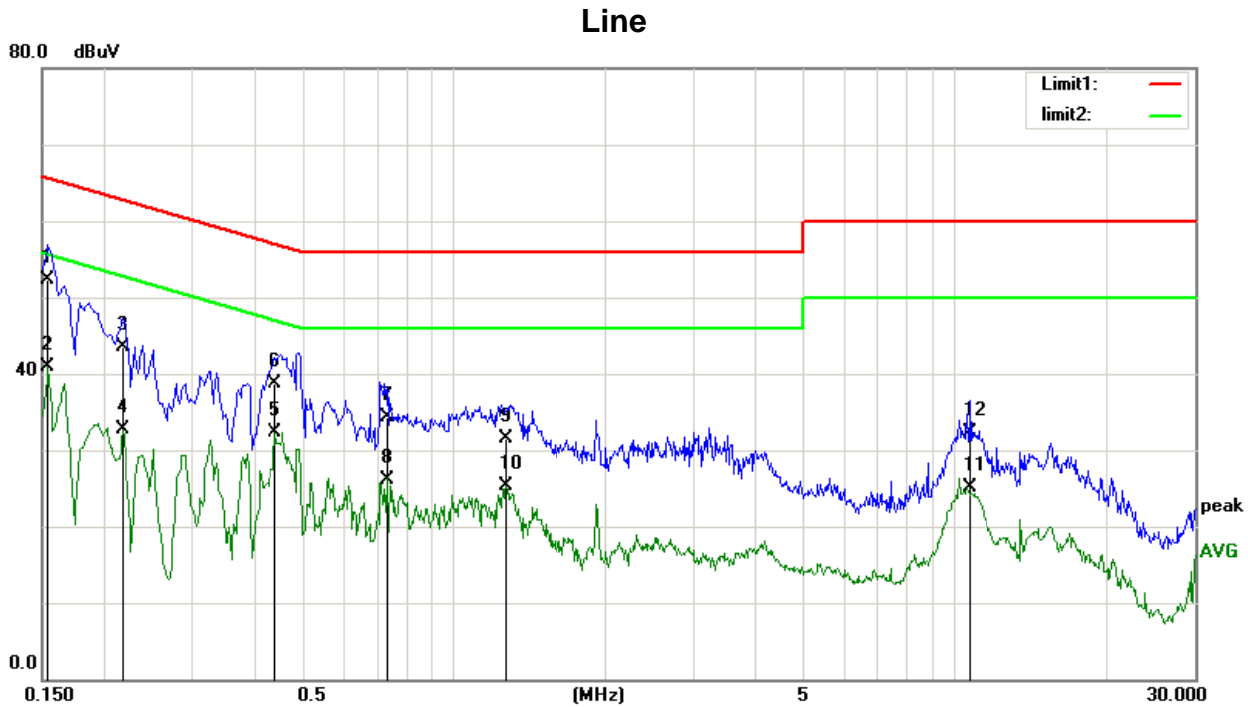

No.	Frequency (MHz)	Reading (dBuV)	Correct Factor(dB)	Result (dBuV)	Limit (dBuV)	Margin (dB)	Remark
1	0.1539	40.86	11.50	52.36	65.78	-13.42	QP
2	0.1539	29.33	11.50	40.83	55.78	-14.95	AVG
3	0.2180	32.42	11.07	43.49	62.89	-19.40	QP
4	0.2180	21.65	11.07	32.72	52.89	-20.17	AVG
5	0.4380	28.29	10.36	38.65	57.10	-18.45	QP
6	0.4380	21.99	10.36	32.35	47.10	-14.75	AVG
7	0.7330	24.06	10.23	34.29	56.00	-21.71	QP
8	0.7330	15.97	10.23	26.20	46.00	-19.80	AVG
9	1.2660	21.27	10.21	31.48	56.00	-24.52	QP
10	1.2660	15.16	10.21	25.37	46.00	-20.63	AVG
11	10.7059	22.03	10.20	32.23	60.00	-27.77	QP
12	10.7059	14.87	10.20	25.07	50.00	-24.93	AVG

Remarks:

(1) Measurement Value = Reading Level + Correct Factor.

(2) Margin Level = Measurement Value - Limit Value.

Test Mode: TX N-40 MHz Mode Channel 03

Neutral

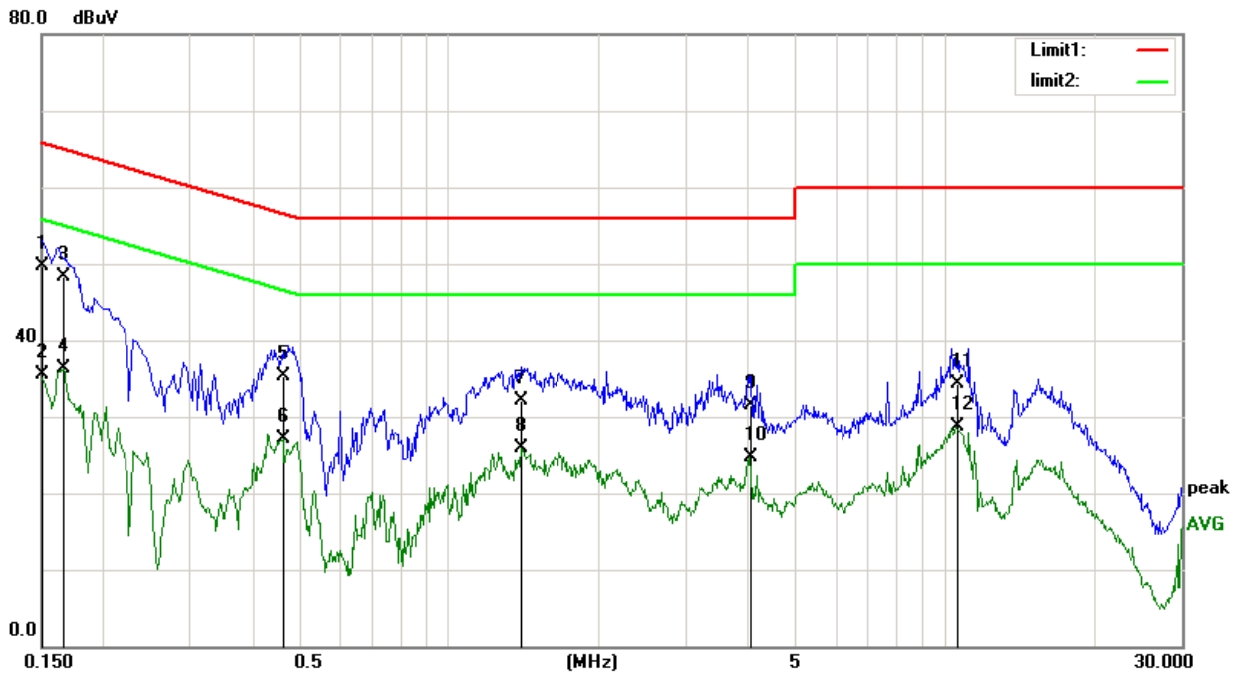

No.	Frequency (MHz)	Reading (dBuV)	Correct Factor(dB)	Result (dBuV)	Limit (dBuV)	Margin (dB)	Remark
1	0.1500	38.12	11.53	49.65	65.99	-16.34	QP
2	0.1500	24.07	11.53	35.60	55.99	-20.39	AVG
3	0.1660	36.94	11.42	48.36	65.15	-16.79	QP
4	0.1660	24.86	11.42	36.28	55.15	-18.87	AVG
5	0.4620	24.91	10.33	35.24	56.66	-21.42	QP
6	0.4620	16.87	10.33	27.20	46.66	-19.46	AVG
7	1.3940	21.94	10.21	32.15	56.00	-23.85	QP
8	1.3940	15.69	10.21	25.90	46.00	-20.10	AVG
9	4.0379	21.30	10.22	31.52	56.00	-24.48	QP
10	4.0379	14.51	10.22	24.73	46.00	-21.27	AVG
11	10.5619	24.09	10.20	34.29	60.00	-25.71	QP
12	10.5619	18.51	10.20	28.71	50.00	-21.29	AVG

Remarks:

- (1) Measurement Value = Reading Level + Correct Factor.
- (2) Margin Level = Measurement Value - Limit Value.

5 RADIATED EMISSIONSTEST

5.1LIMIT

In case the emission fall within the restricted band specified on 15.205(a) and RSS-Gen 8.10, then the 15.209(a) andRSS-Gen 8.9limit in the table below has to be followed.

LIMITS OF RADIATED EMISSION MEASUREMENT (9 kHz-1000MHz)

Frequency (MHz)	Field Strength (microvolts/meter)	Measurement Distance (meters)
0.009-0.490	2400/F(kHz)	300
0.490-1.705	24000/F(kHz)	30
1.705-30.0	30	30
30-88	100	3
88-216	150	3
216-960	200	3
Above 960	500	3

LIMITS OF RADIATED EMISSION MEASUREMENT (9 kHz-30 MHz)

Frequency (MHz)	Magnetic field strength (H-Field) (μ A/m)	Measurement Distance (meters)
0.009-0.490	6.37/F(kHz)	300
0.490-1.705	6.37/F(kHz)	30
1.705-30.0	0.08	30

LIMITS OF RADIATED EMISSION MEASUREMENT (30 MHz-1000MHz)

Frequency (MHz)	Field Strength (μ V/m at 3m)
30-88	100
88-216	150
216-960	200
Above 960	500

LIMITS OF RADIATED EMISSION MEASUREMENT (Above 1000MHz)

Frequency (MHz)	(dBuV/m at 3 m)	
	Peak	Average
Above 1000	74	54

NOTE:

- (1) The limit for radiated test was performed according to FCC PART 15C and RSS-247.
- (2) The tighter limit applies at the band edges.
- (3) Emission level (dBuV/m)=20log Emission level (uV/m).

5.2 TEST PROCEDURE

- a. The measuring distance of 3 m shall be used for measurements. The EUT was placed on the top of a rotating table 0.8 meter above the ground at a 3 meter semi-anechoic chamber. The table was rotated 360 degrees to determine the position of the highest radiation.(below 1GHz)
- b. The measuring distance of 3 m shall be used for measurements. The EUT was placed on the top of a rotating table 1.5 meter above the ground at a 3 meter semi-anechoic chamber. The table was rotated 360 degrees to determine the position of the highest radiation.(above 1GHz)
- c. The height of the equipment or of the substitution antenna shall be 0.8m or 1.5m; the height of the test antenna shall vary between 1 m to 4 m. Both horizontal and vertical polarizations of the antenna are set to make the measurement.
- d. For each suspected emission, the EUT was arranged to its worst case and then the antenna was tuned to heights find the maximum reading (used Bore sight function).
- e. The receiver system was set to peak and average detect function and specified bandwidth with maximum hold mode when the test frequency is above 1GHz.
- f. The initial step in collecting radiated emission data is a receiver peak detector mode pre-scanning the measurement frequency range. Significant peaks are then marked and then Quasi Peak detector mode re-measured.
- g. All readings are Peak unless otherwise stated QP in column of Note. Peak denotes that the Peak reading compliance with the QP Limits and then QP Mode measurement didn't perform. (below 1GHz)
- h. All readings are Peak Mode value unless otherwise stated AVG in column of Note. If the Peak Mode Measured value compliance with the Peak Limits and lower than AVG Limits, the EUT shall be deemed to meet both Peak & AVG Limits and then only Peak Mode was measured, but AVG Mode didn't perform. (above 1GHz)
- i. The test result is calculated as the following:
 - (1) Result = Reading + Correct Factor
 - (2) Correct Factor = Antenna Factor + Cable Loss – Amplifier Gain + Attenuator
 - (3) Margin = Result - Limit

Spectrum Parameter	Setting
Attenuation	Auto
Start Frequency	1000 MHz
Stop Frequency	10th carrier harmonic
RBW / VBW (Emission in restricted band)	1MHz / 3MHz for Peak, 1MHz / 1/T for Average

Receiver Parameter	Setting
Attenuation	Auto
Start ~ Stop Frequency	9 kHz~90 kHz for PK/AVG detector
Start ~ Stop Frequency	90 kHz~110 kHz for QP detector
Start ~ Stop Frequency	110 kHz~490 kHz for PK/AVG detector
Start ~ Stop Frequency	490 kHz~30 MHz for QP detector
Start ~ Stop Frequency	30MHz~1000MHz for QP detector

5.3 MEASUREMENT INSTRUMENTS LIST

Item	Equipment	Manufacturer	Model No.	Serial No.	Calibrated until
1	EMI Test Receiver	R&S	ESCI	101307	12/12/2021
2	Spectrum Analyzer	Agilent	E4407B	US40240708	11/17/2021
3	Loop antenna	SCHWARZBECK K	FMZB1519	1519-062	12/14/2021
4	Broadband antenna	SCHWARZBECK	VULB9168	VULB9168-192	08/06/2021
5	HORN ANTENNA	SCHWARZBECK	BBHA9120D	9120D 1065	04/21/2022
6	Preamplifier Amplifier	HP	8447F	3113A05680	12/11/2021
7	PRE-AMPLIFIER	CY	EMC011830	980136	12/11/2021
8	RF Cable	R&S	Test Cable 4	4	12/11/2021
9	RF Cable	R&S	Test Cable 5	5	12/11/2021
10	RF Cable	R&S	Test Cable 9	9	04/21/2022
11	RF Cable	R&S	Test Cable 10	10	12/11/2021
12	Measurement Software	Farad	EZ-EMC (Ver.ATT-03A)	N/A	N/A

5.4 TEST SETUP

9 kHz-30 MHz

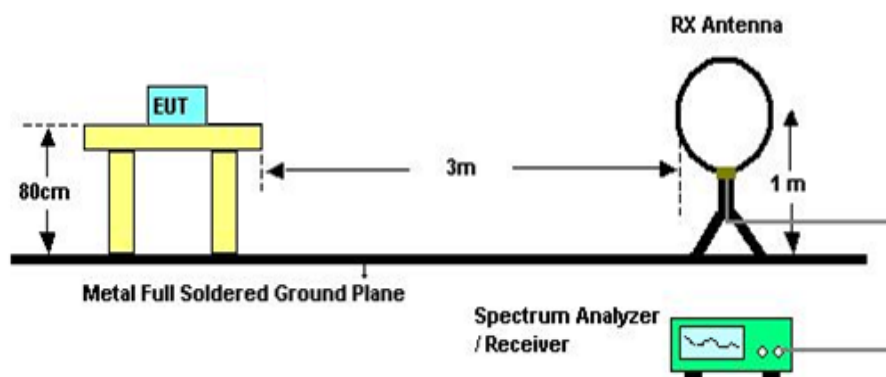

30 MHz to 1 GHz

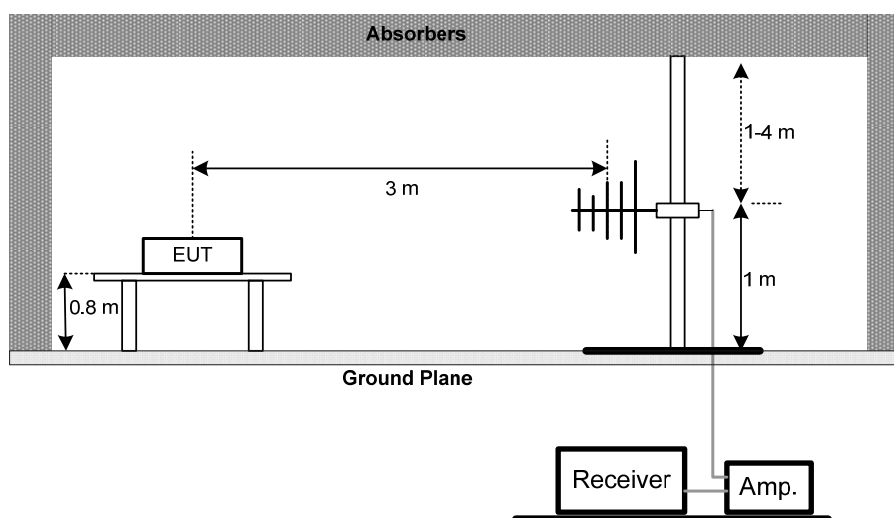

Above 1 GHz

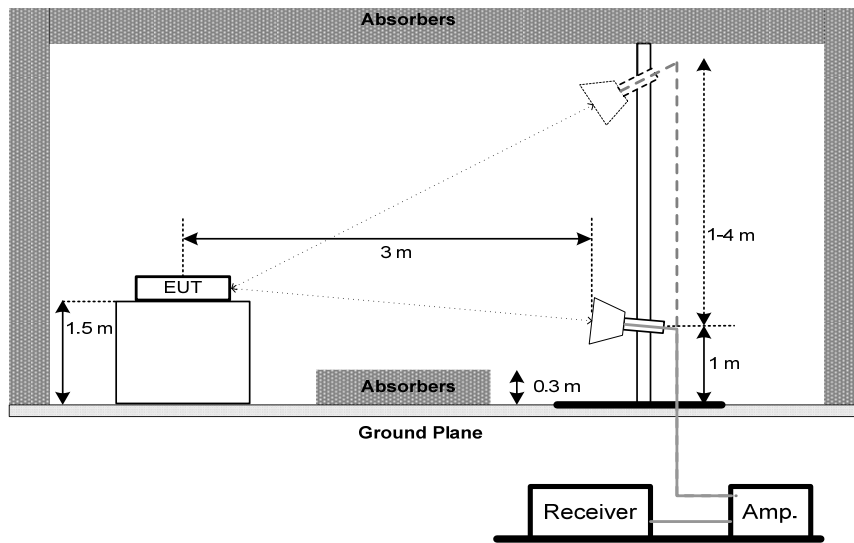

5.5 EUT OPERATION CONDITIONS

The EUT was programmed to be in continuously transmitting mode.

5.6 TEST RESULTS - 9kHz TO 30MHz

Test Mode:	TX N-40 MHz Mode Channel 03
------------	-----------------------------

Freq.	Reading	Limit	Margin	State
(MHz)	(dBuV/m)	(dBuV/m)	(dB)	P/F
--	--	--	--	P
--	--	--	--	P

Note:

The amplitude of spurious emissions which are attenuated by more than 20dB below the permissible value has no need to be reported.

Distance extrapolation factor = $20 \log (\text{specific distance}/\text{test distance})(\text{dB})$;

Limit line = specific limits(dBuv) + distance extrapolation factor

5.7 TEST RESULTS - 30MHz TO 1000MHz

Test Mode : TX N-40 MHz Mode Channel 03

Vertical

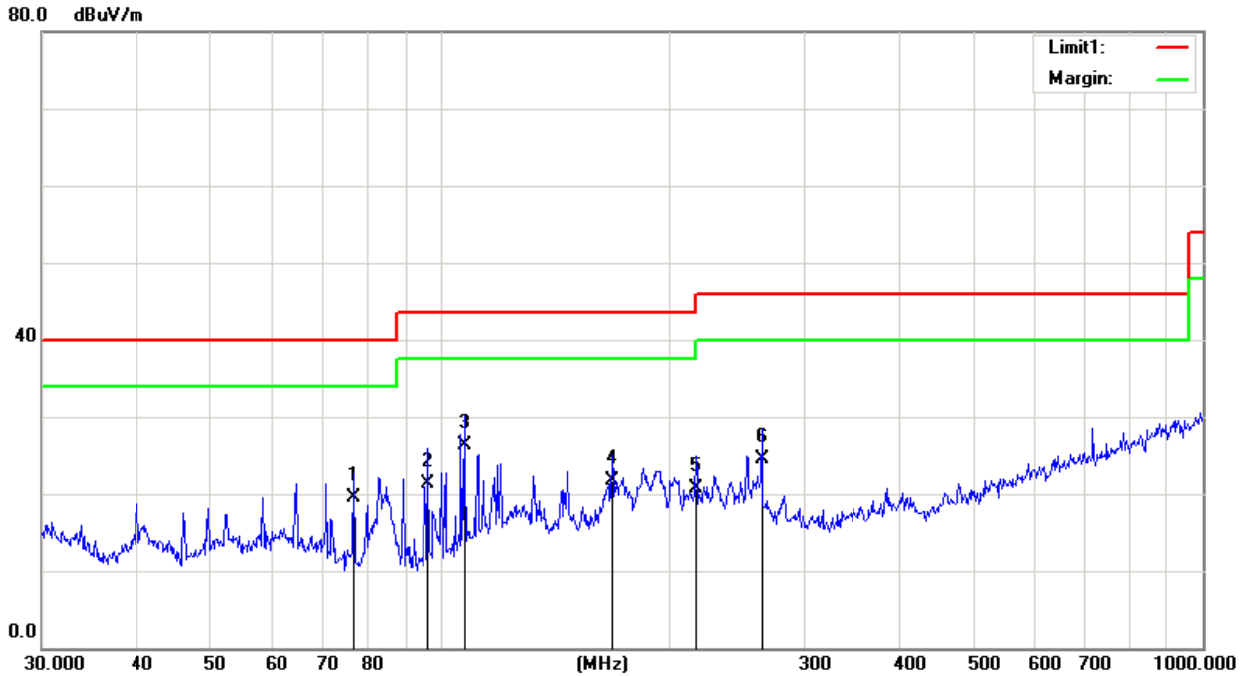

No.	Frequency (MHz)	Reading (dBuV/m)	Correct Factor(dB/m)	Result (dBuV/m)	Limit (dBuV/m)	Margin (dB)	Remark
1	76.7807	34.53	-14.99	19.54	40.00	-20.46	QP
2	96.0986	36.08	-14.73	21.35	43.50	-22.15	QP
3	107.5100	40.85	-14.48	26.37	43.50	-17.13	QP
4	167.8242	32.12	-10.48	21.64	43.50	-21.86	QP
5	216.0240	31.26	-10.58	20.68	46.00	-25.32	QP
6	263.8190	32.62	-8.05	24.57	46.00	-21.43	QP

Test Mode : TX N-40 MHz Mode Channel 03

Horizontal

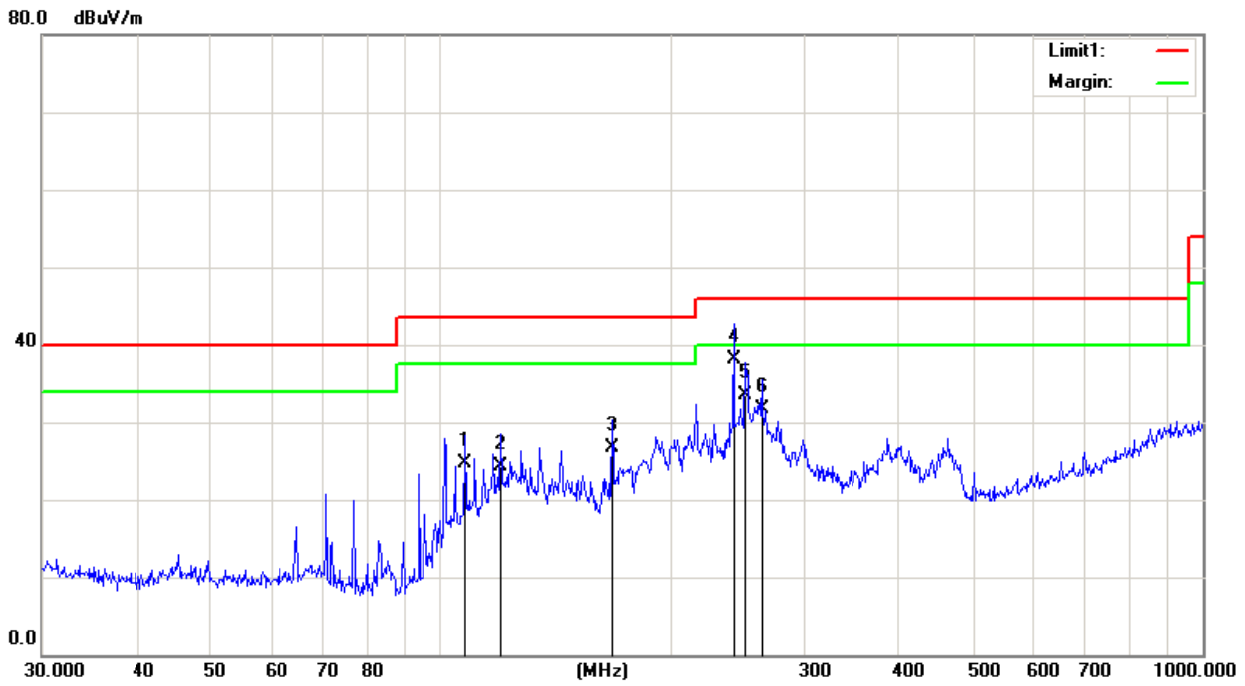

No.	Frequency (MHz)	Reading (dBuV/m)	Correct Factor (dB/m)	Result (dBuV/m)	Limit (dBuV/m)	Margin (dB)	Remark
1	107.8877	39.53	-14.85	24.68	43.50	-18.82	QP
2	119.8556	38.25	-13.89	24.36	43.50	-19.14	QP
3	167.8243	37.66	-10.91	26.75	43.50	-16.75	QP
4	242.5253	44.35	-6.16	38.19	46.00	-7.81	QP
5	251.1804	39.53	-6.04	33.49	46.00	-12.51	QP
6	263.8190	36.50	-4.76	31.74	46.00	-14.26	QP

5.8 TEST RESULTS- ABOVE 1000MHz(BAND EDGE)

Orthogonal Axis	X
Test Mode:	TX B Mode 2412 MHz

Vertical

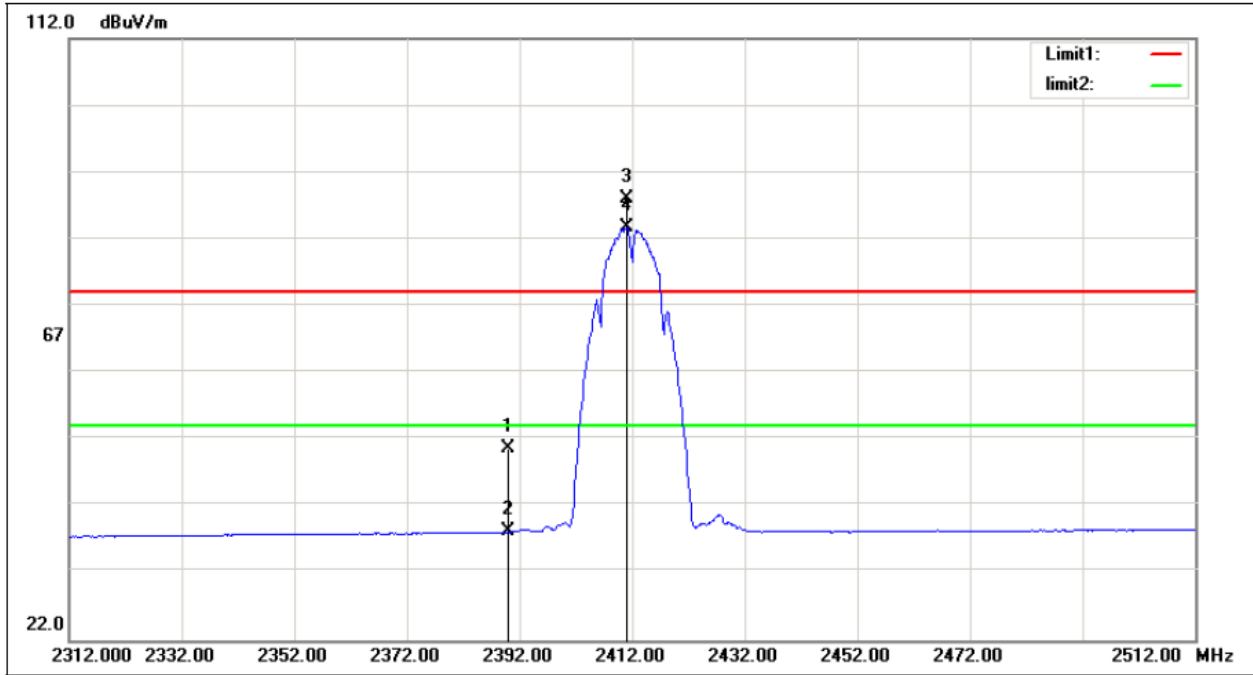

No.	Frequency (MHz)	Reading (dBuV/m)	Correct Factor(dB/m)	Result (dBuV/m)	Limit (dBuV/m)	Margin (dB)	Remark
1	2390.000	22.56	28.19	50.75	74.00	-23.25	peak
2	2390.000	10.02	28.19	38.21	54.00	-15.79	AVG
3	2411.200	59.86	28.25	88.11	/	/	peak
4	2411.200	55.53	28.25	83.78	/	/	AVG

Orthogonal Axis	X
Test Mode:	TX B Mode 2412 MHz

Horizontal

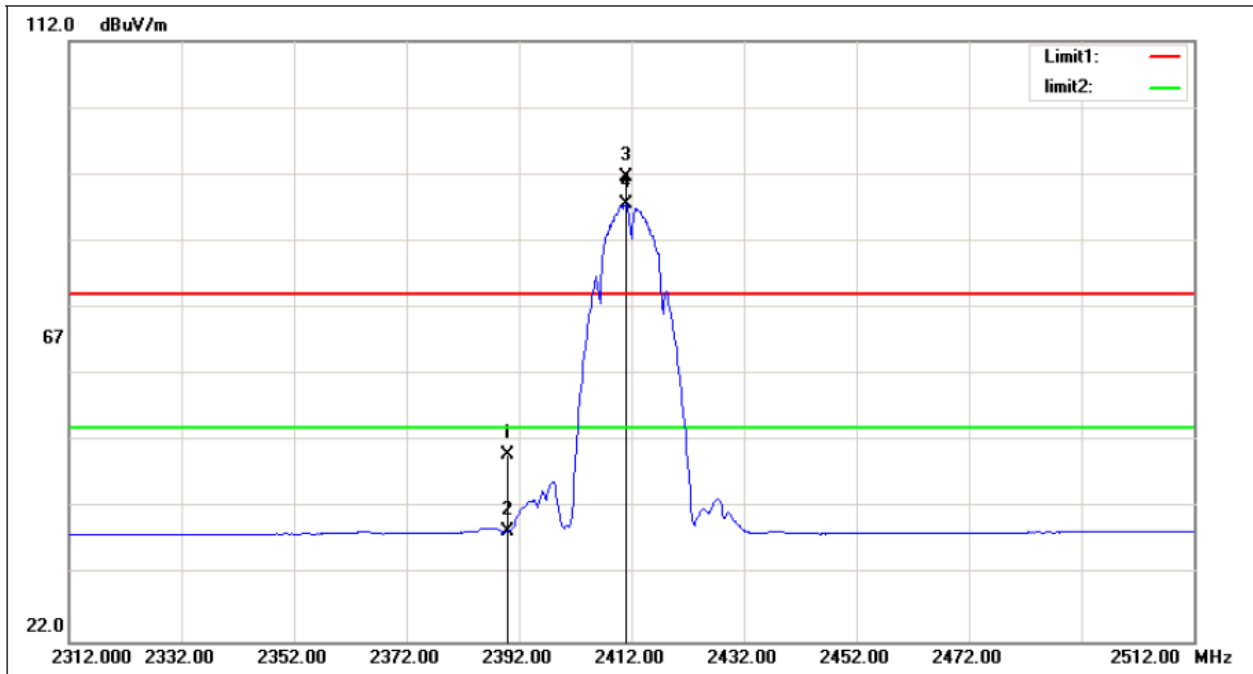

No.	Frequency (MHz)	Reading (dBuV/m)	Correct Factor(dB/m)	Result (dBuV/m)	Limit (dBuV/m)	Margin (dB)	Remark
1	2390.000	21.73	28.19	49.92	74.00	-24.08	peak
2	2390.000	10.43	28.19	38.62	54.00	-15.38	AVG
3	2411.000	63.41	28.25	91.66	/	/	peak
4	2411.200	59.34	28.25	87.59	/	/	AVG

Orthogonal Axis	X
Test Mode:	TX B Mode 2462 MHz

Vertical

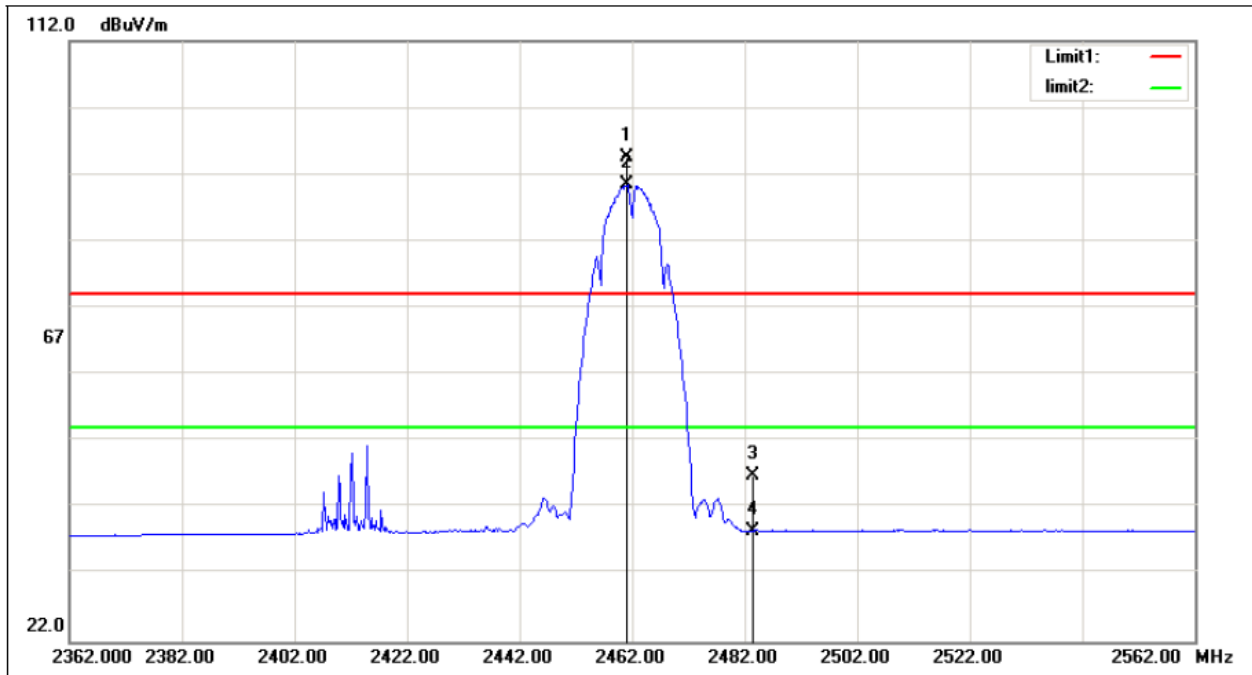

No.	Frequency (MHz)	Reading (dBuV/m)	Correct Factor(dB/m)	Result (dBuV/m)	Limit (dBuV/m)	Margin (dB)	Remark
1	2461.000	66.17	28.38	94.55	/	/	peak
2	2461.200	62.21	28.38	90.59	/	/	AVG
3	2483.500	18.34	28.43	46.77	74.00	-27.23	peak
4	2483.500	10.20	28.43	38.63	54.00	-15.37	AVG

Orthogonal Axis	X
Test Mode:	TX B Mode 2462 MHz

Horizontal

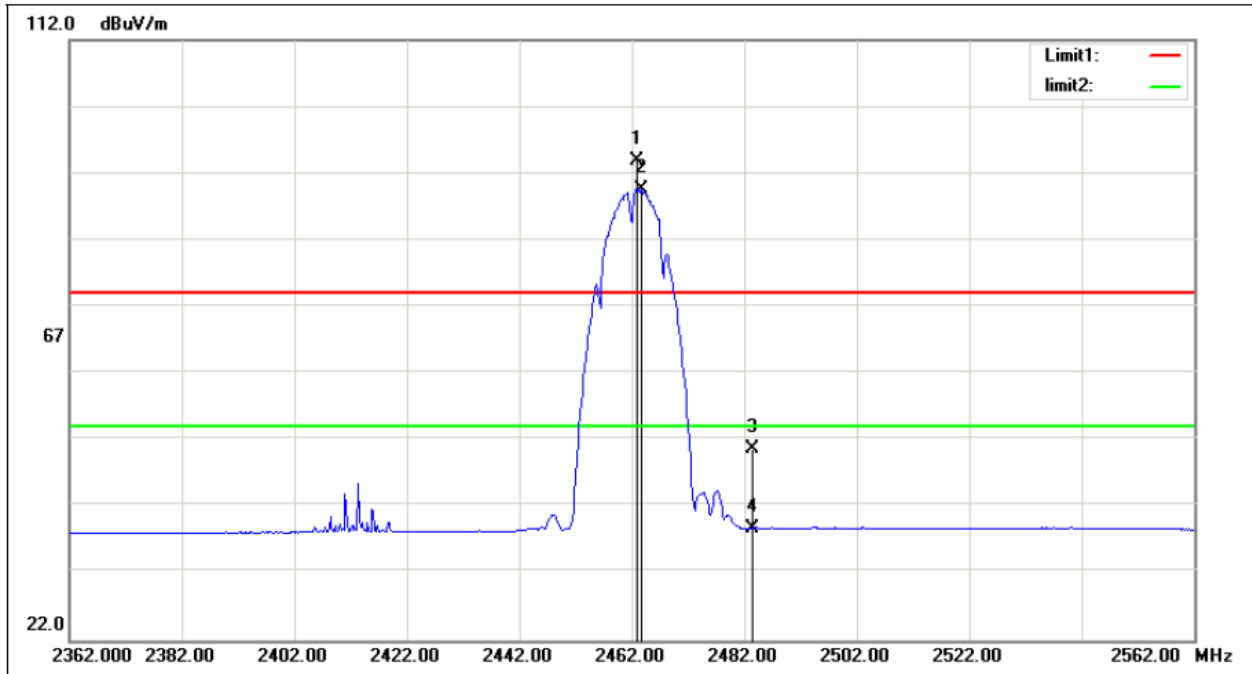

No.	Frequency (MHz)	Reading (dBuV/m)	Correct Factor (dB/m)	Result (dBuV/m)	Limit (dBuV/m)	Margin (dB)	Remark
1	2463.000	65.56	28.39	93.95	/	/	peak
2	2463.800	61.31	28.39	89.70	/	/	AVG
3	2483.500	22.17	28.43	50.60	74.00	-23.40	peak
4	2483.500	10.43	28.43	38.86	54.00	-15.14	AVG

Orthogonal Axis	X
Test Mode:	TX G Mode 2412 MHz

Vertical

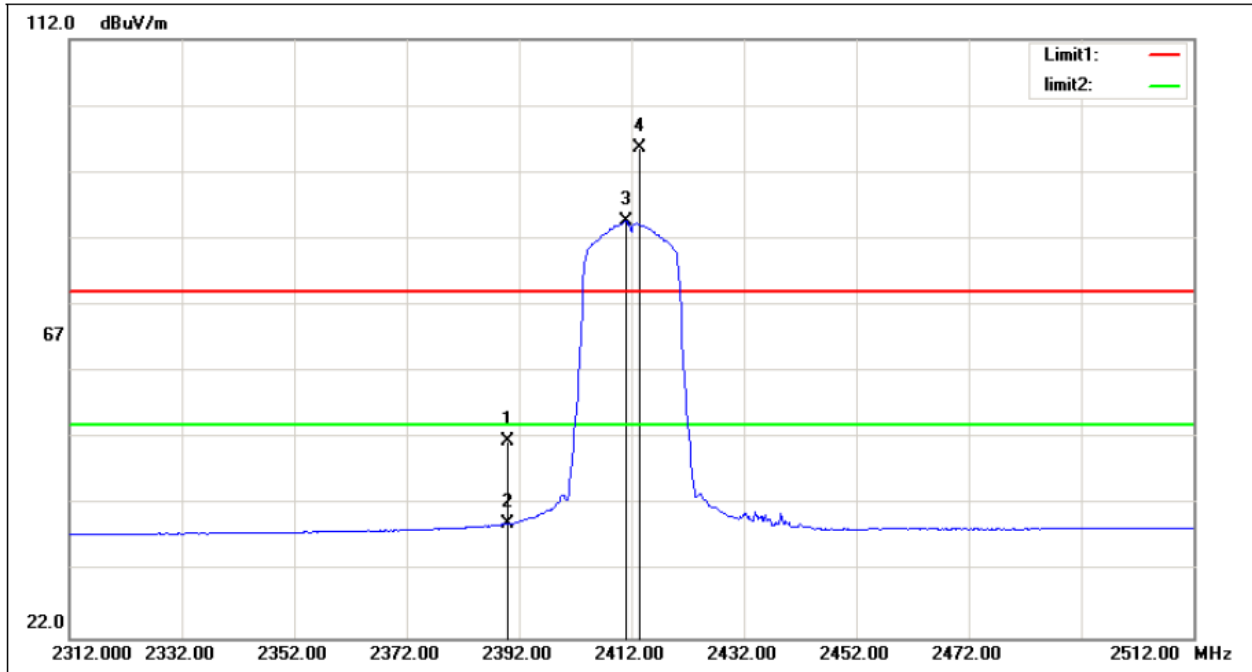

No.	Frequency (MHz)	Reading (dBuV/m)	Correct Factor(dB/m)	Result (dBuV/m)	Limit (dBuV/m)	Margin (dB)	Remark
1	2390.000	23.39	28.19	51.58	74.00	-22.42	peak
2	2390.000	11.01	28.19	39.20	54.00	-14.80	AVG
3	2411.200	56.33	28.25	84.58	/	/	AVG
4	2413.600	67.37	28.26	95.63	/	/	peak

Orthogonal Axis	X
Test Mode:	TX G Mode 2412 MHz

Horizontal

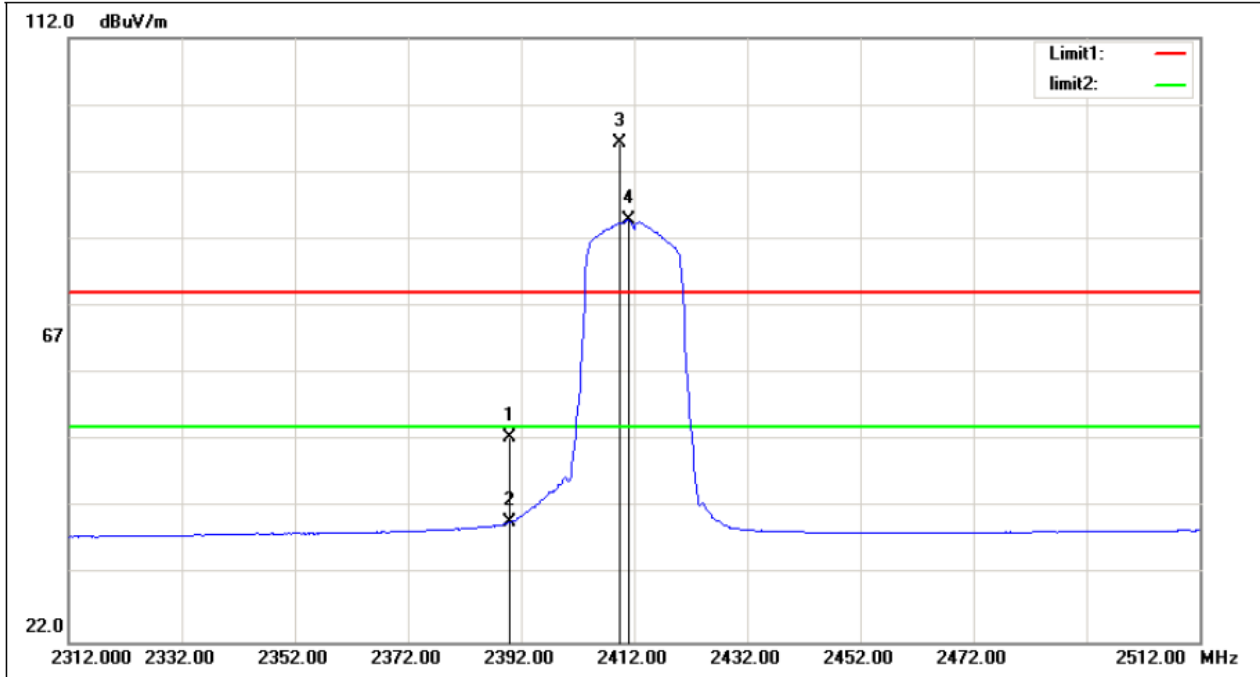

No.	Frequency (MHz)	Reading (dBuV/m)	Correct Factor(dB/m)	Result (dBuV/m)	Limit (dBuV/m)	Margin (dB)	Remark
1	2390.000	24.30	28.19	52.49	74.00	-21.51	peak
2	2390.000	11.76	28.19	39.95	54.00	-14.05	AVG
3	2409.400	68.16	28.25	96.41	/	/	peak
4	2411.000	56.61	28.25	84.86	/	/	AVG

Orthogonal Axis	X
Test Mode:	TX G Mode 2462 MHz

Vertical

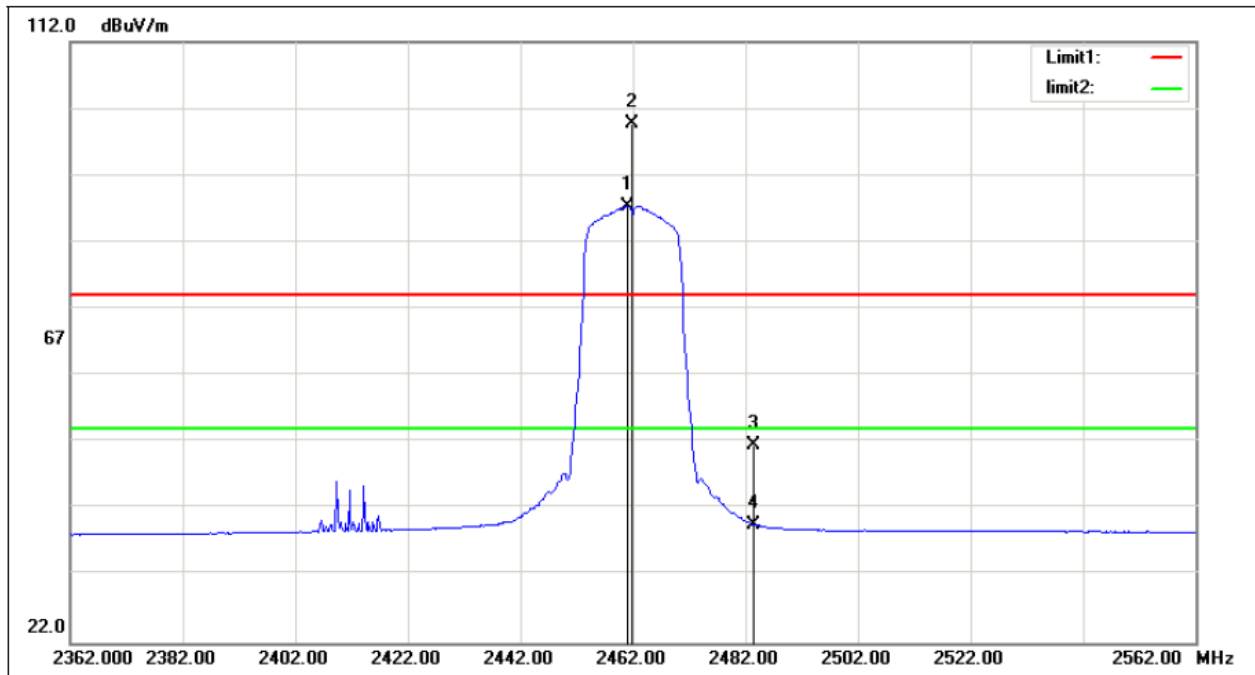

No.	Frequency (MHz)	Reading (dBuV/m)	Correct Factor(dB/m)	Result (dBuV/m)	Limit (dBuV/m)	Margin (dB)	Remark
1	2461.000	59.00	28.38	87.38	/	/	AVG
2	2461.800	71.34	28.38	99.72	/	/	peak
3	2483.500	23.14	28.43	51.57	74.00	-22.43	peak
4	2483.500	11.26	28.43	39.69	54.00	-14.31	AVG

Orthogonal Axis	X
Test Mode:	TX G Mode 2462 MHz

Horizontal

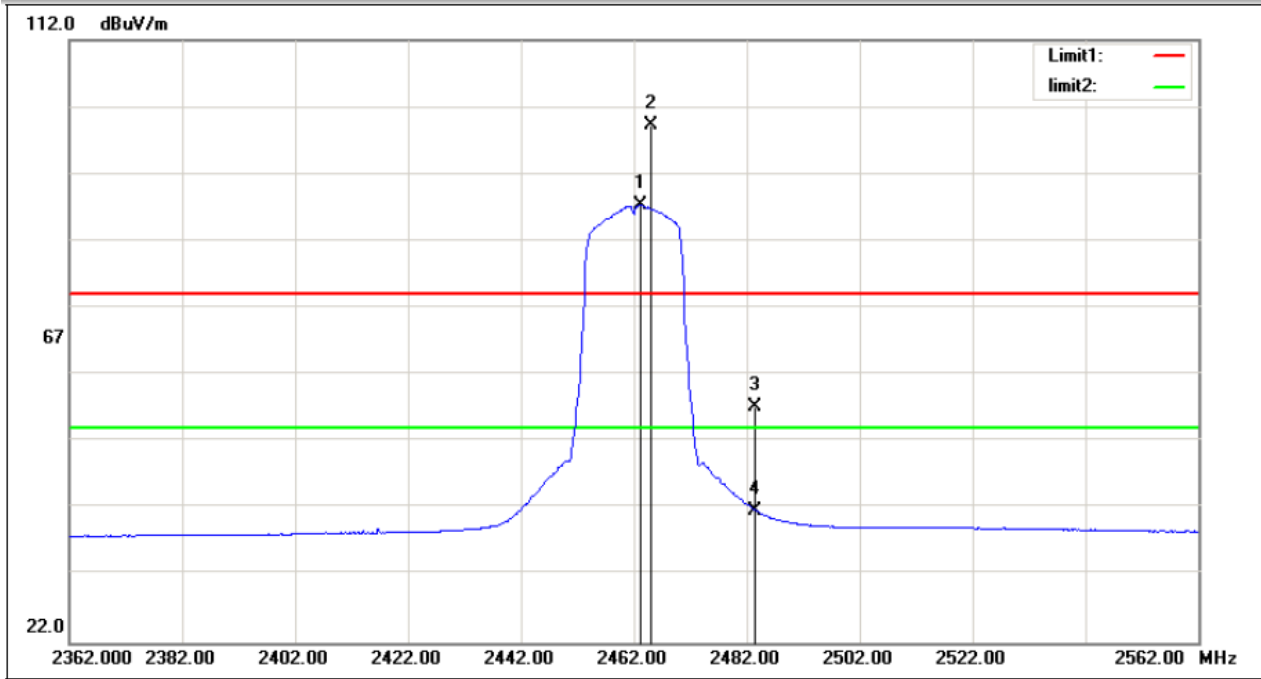

No.	Frequency (MHz)	Reading (dBuV/m)	Correct Factor(dB/m)	Result (dBuV/m)	Limit (dBuV/m)	Margin (dB)	Remark
1	2463.200	59.02	28.39	87.41	/	/	AVG
2	2465.000	70.98	28.39	99.37	/	/	peak
3	2483.500	28.70	28.43	57.13	74.00	-16.87	peak
4	2483.500	13.35	28.43	41.78	54.00	-12.22	AVG

Orthogonal Axis	X
Test Mode:	TX N-20M Mode 2412 MHz

Vertical

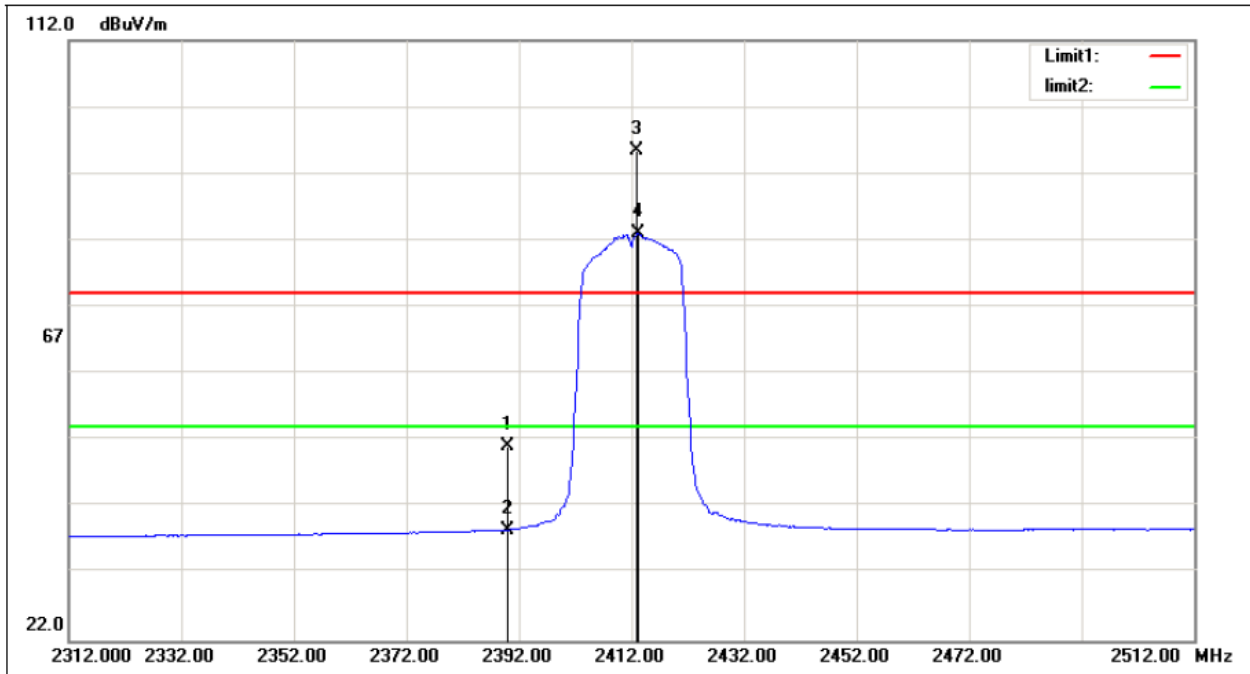

No.	Frequency (MHz)	Reading (dBuV/m)	Correct Factor(dB/m)	Result (dBuV/m)	Limit (dBuV/m)	Margin (dB)	Remark
1	2390.000	22.89	28.19	51.08	74.00	-22.92	peak
2	2390.000	10.46	28.19	38.65	54.00	-15.35	AVG
3	2412.000	67.27	28.26	95.53	/	/	peak
4	2412.200	54.74	28.26	83.00	/	/	AVG

Orthogonal Axis	X
Test Mode:	TX N-20M Mode 2412 MHz

Horizontal

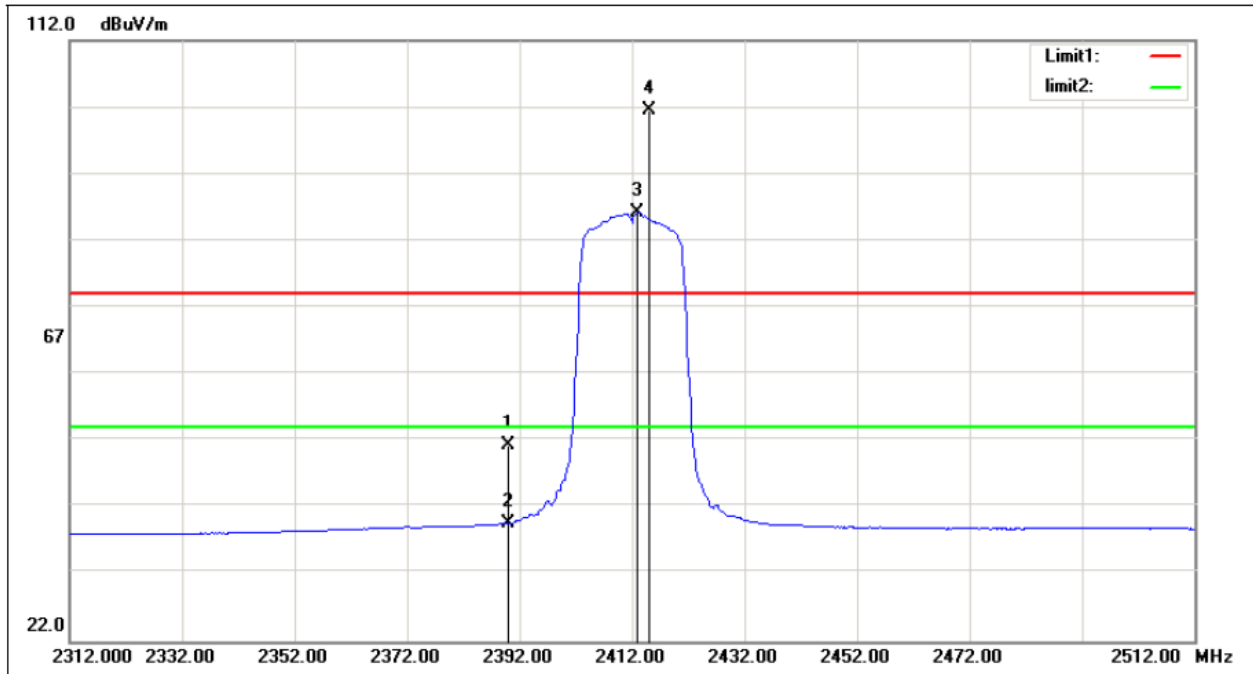

No.	Frequency (MHz)	Reading (dBuV/m)	Correct Factor(dB/m)	Result (dBuV/m)	Limit (dBuV/m)	Margin (dB)	Remark
1	2390.000	23.10	28.19	51.29	74.00	-22.71	peak
2	2390.000	11.54	28.19	39.73	54.00	-14.27	AVG
3	2413.000	58.05	28.26	86.31	/	/	AVG
4	2415.200	73.17	28.26	101.43	/	/	peak

Orthogonal Axis	X
Test Mode:	TX N-20M Mode 2462 MHz

Vertical

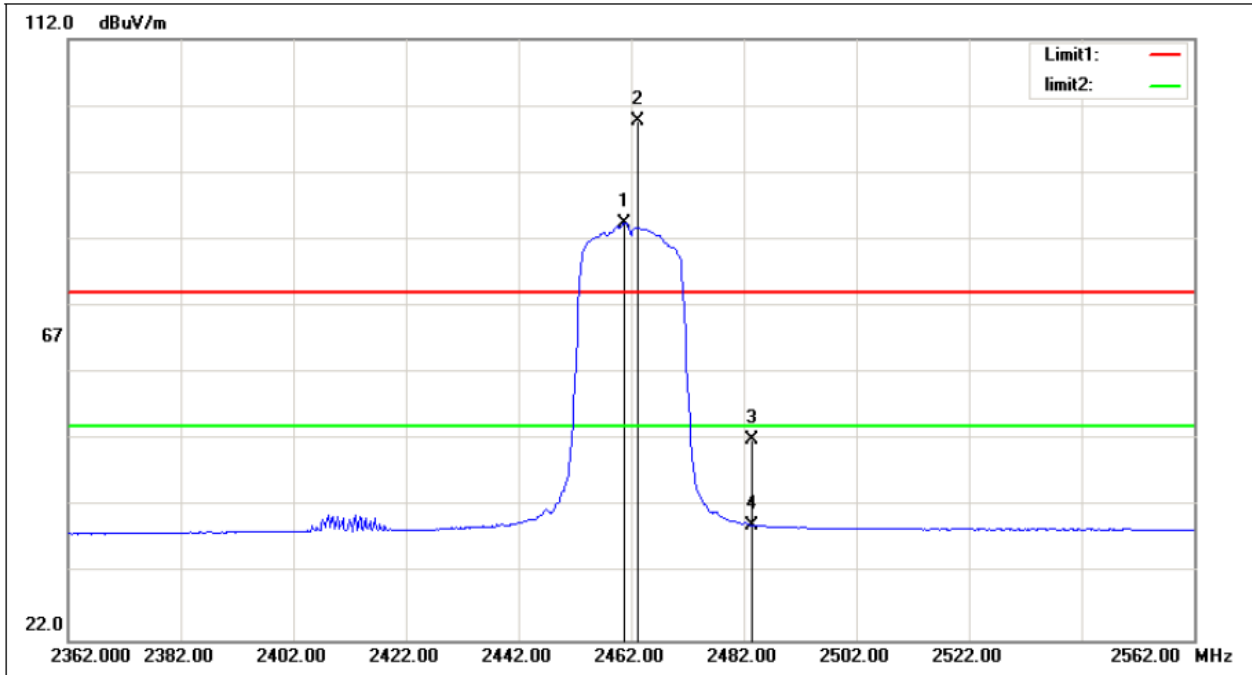

No.	Frequency (MHz)	Reading (dBuV/m)	Correct Factor(dB/m)	Result (dBuV/m)	Limit (dBuV/m)	Margin (dB)	Remark
1	2460.800	56.10	28.38	84.48	/	/	AVG
2	2463.200	71.41	28.39	99.80	/	/	peak
3	2483.500	23.72	28.43	52.15	74.00	-21.85	peak
4	2483.500	10.84	28.43	39.27	54.00	-14.73	AVG

Orthogonal Axis	X
Test Mode:	TX N-20M Mode 2462 MHz

Horizontal

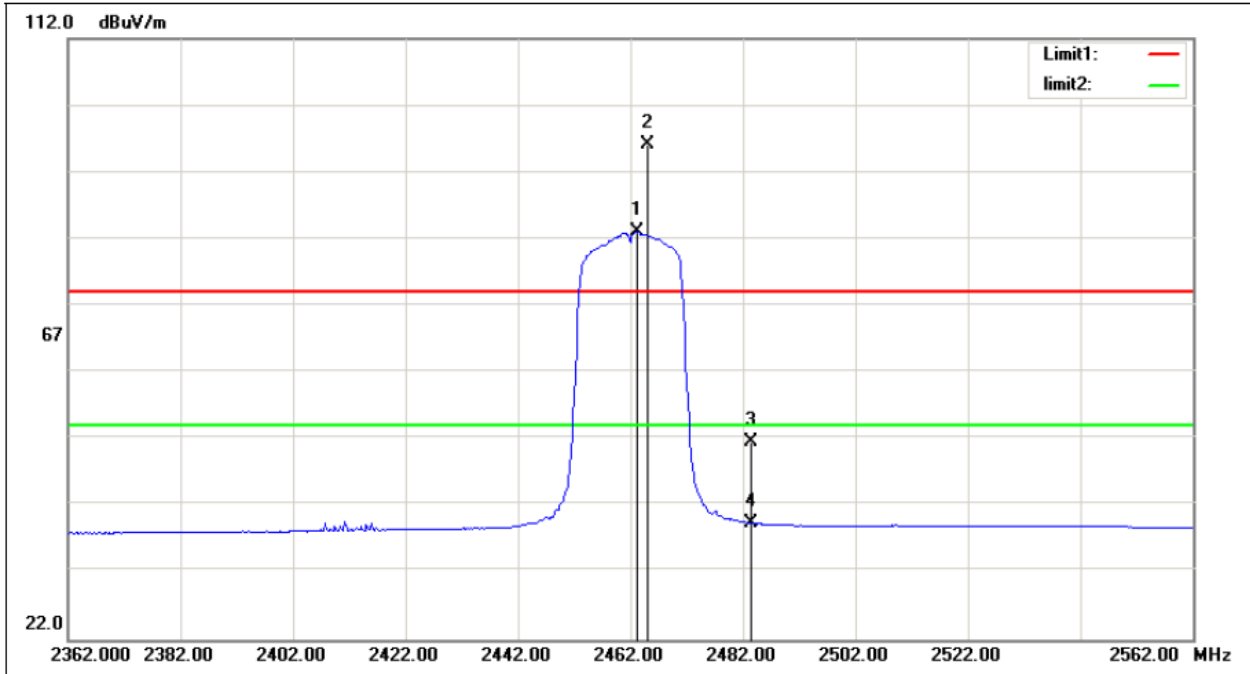

No.	Frequency (MHz)	Reading (dBuV/m)	Correct Factor(dB/m)	Result (dBuV/m)	Limit (dBuV/m)	Margin (dB)	Remark
1	2463.200	54.69	28.39	83.08	/	/	AVG
2	2465.200	67.80	28.39	96.19	/	/	peak
3	2483.500	23.05	28.43	51.48	74.00	-22.52	peak
4	2483.500	10.97	28.43	39.40	54.00	-14.60	AVG

Orthogonal Axis	X
Test Mode:	TX N-40M Mode 2422MHz

Vertical

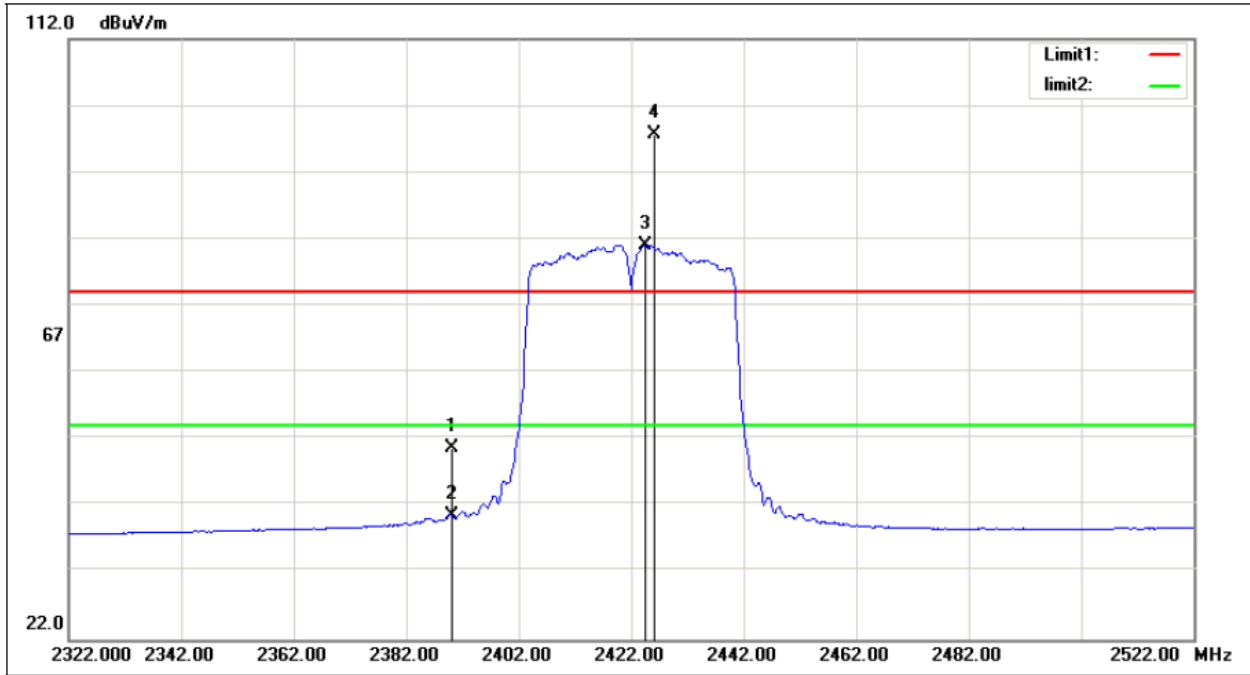

No.	Frequency (MHz)	Reading (dBuV/m)	Correct Factor(dB/m)	Result (dBuV/m)	Limit (dBuV/m)	Margin (dB)	Remark
1	2390.000	22.55	28.19	50.74	74.00	-23.26	peak
2	2390.000	12.42	28.19	40.61	54.00	-13.39	AVG
3	2424.400	52.86	28.28	81.14	/	/	AVG
4	2426.000	69.38	28.28	97.66	/	/	peak

Orthogonal Axis	X
Test Mode:	TX N-40M Mode 2422MHz

Horizontal

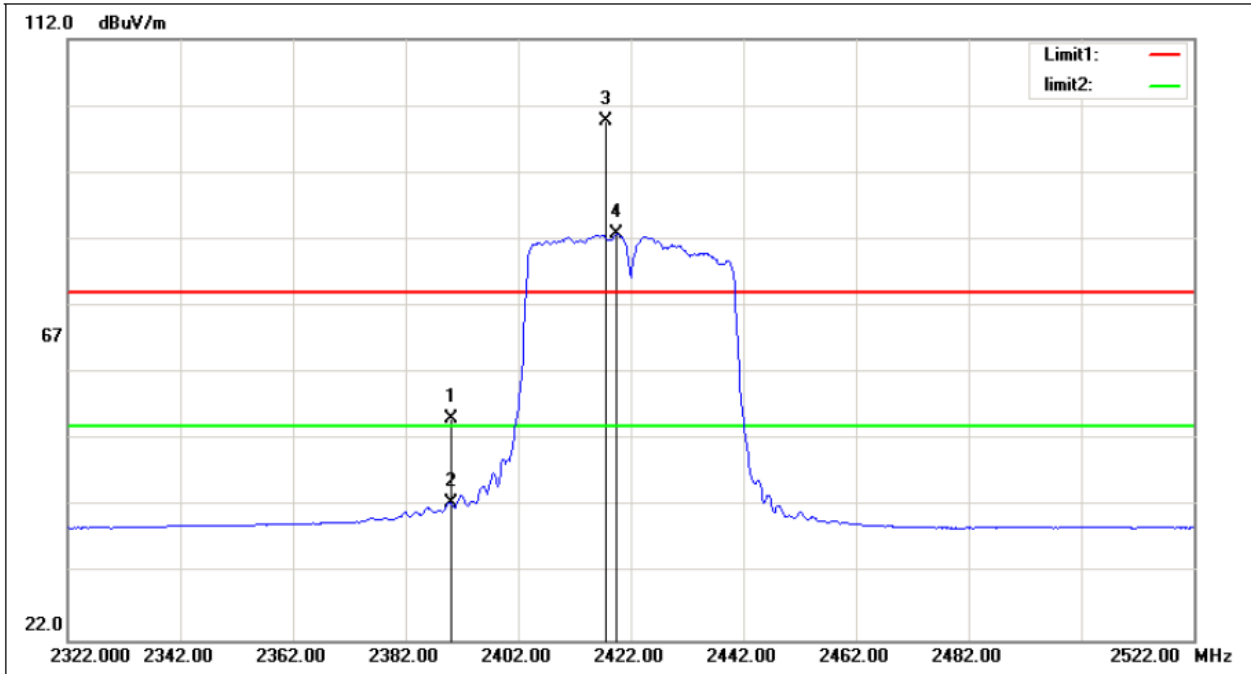

No.	Frequency (MHz)	Reading (dBuV/m)	Correct Factor(dB/m)	Result (dBuV/m)	Limit (dBuV/m)	Margin (dB)	Remark
1	2390.000	27.06	28.19	55.25	74.00	-18.75	peak
2	2390.000	14.36	28.19	42.55	54.00	-11.45	AVG
3	2417.600	71.58	28.26	99.84	/	/	peak
4	2419.400	54.53	28.26	82.79	/	/	AVG

Orthogonal Axis	X
Test Mode:	TX N-40M Mode 2452 MHz

Vertical

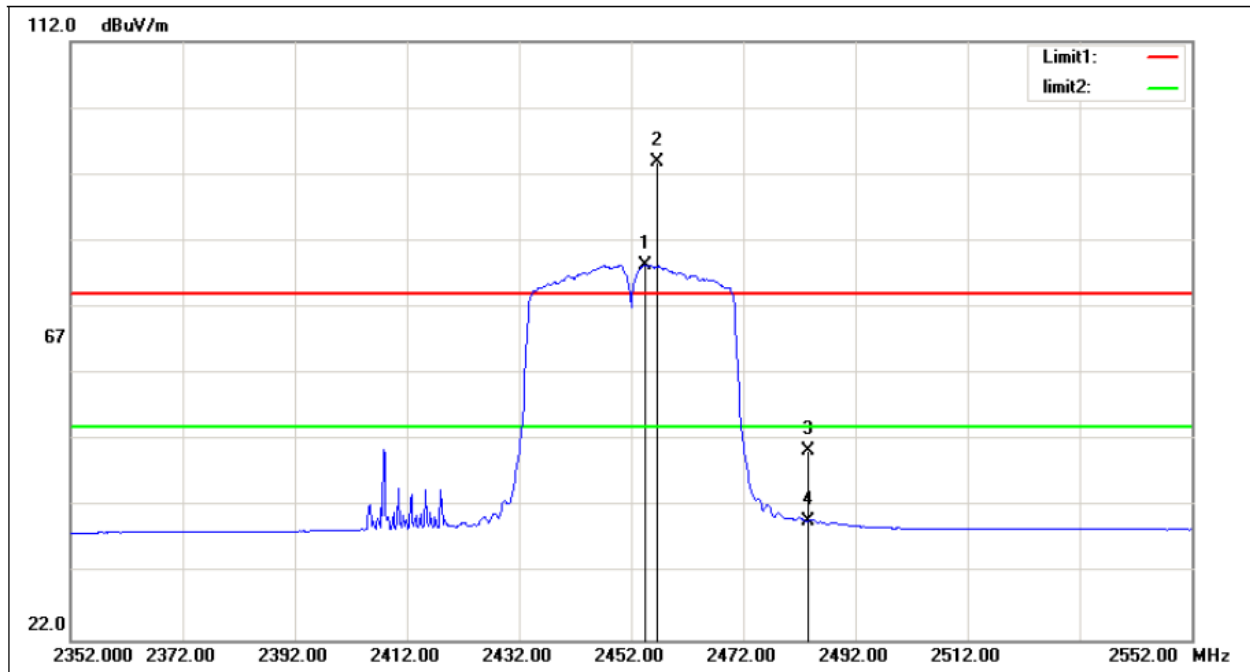

No.	Frequency (MHz)	Reading (dBuV/m)	Correct Factor (dB/m)	Result (dBuV/m)	Limit (dBuV/m)	Margin (dB)	Remark
1	2454.400	50.03	28.36	78.39	/	/	AVG
2	2456.600	65.58	28.37	93.95	/	/	peak
3	2483.500	22.02	28.43	50.45	74.00	-23.55	peak
4	2483.500	11.53	28.43	39.96	54.00	-14.04	AVG

Orthogonal Axis	X
Test Mode:	TX N-40M Mode 2452 MHz

Horizontal

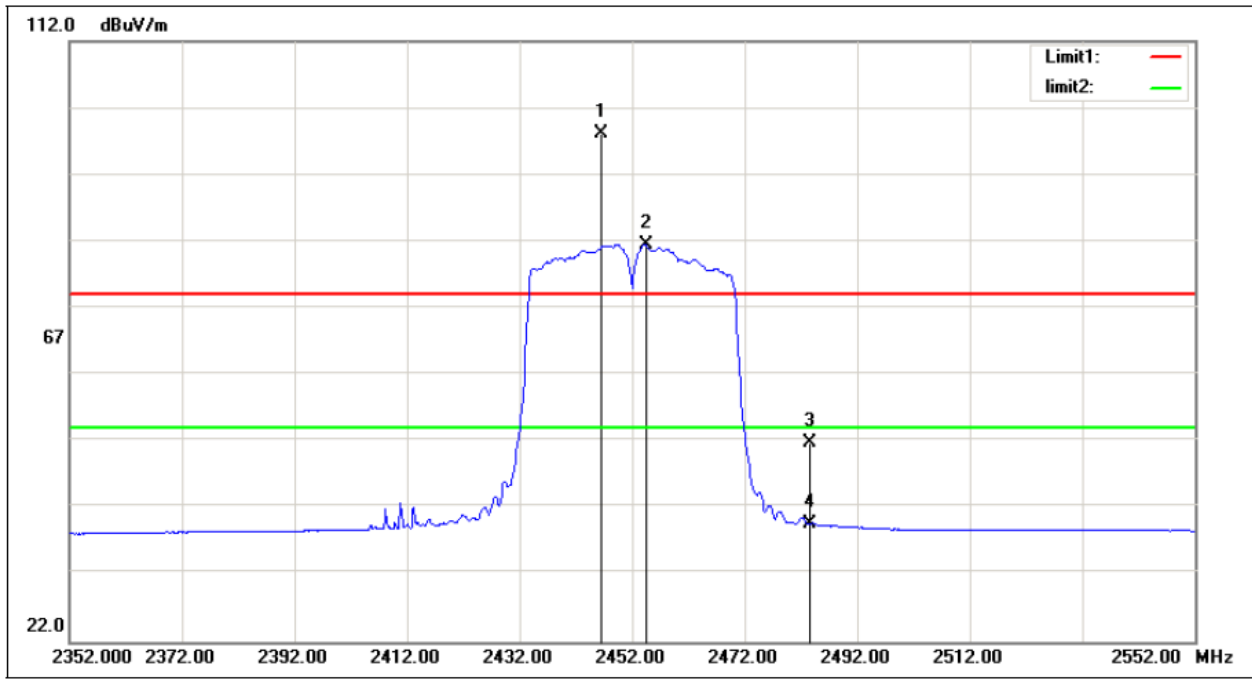

No.	Frequency (MHz)	Reading (dBuV/m)	Correct Factor(dB/m)	Result (dBuV/m)	Limit (dBuV/m)	Margin (dB)	Remark
1	2446.600	69.84	28.34	98.18	/	/	peak
2	2454.400	53.24	28.36	81.60	/	/	AVG
3	2483.500	23.35	28.43	51.78	74.00	-22.22	peak
4	2483.500	11.22	28.43	39.65	54.00	-14.35	AVG

5.9TEST RESULTS- ABOVE 1000MHz(HARMONIC)

Orthogonal Axis	X
Test Mode:	TX B Mode 2412 MHz

Vertical

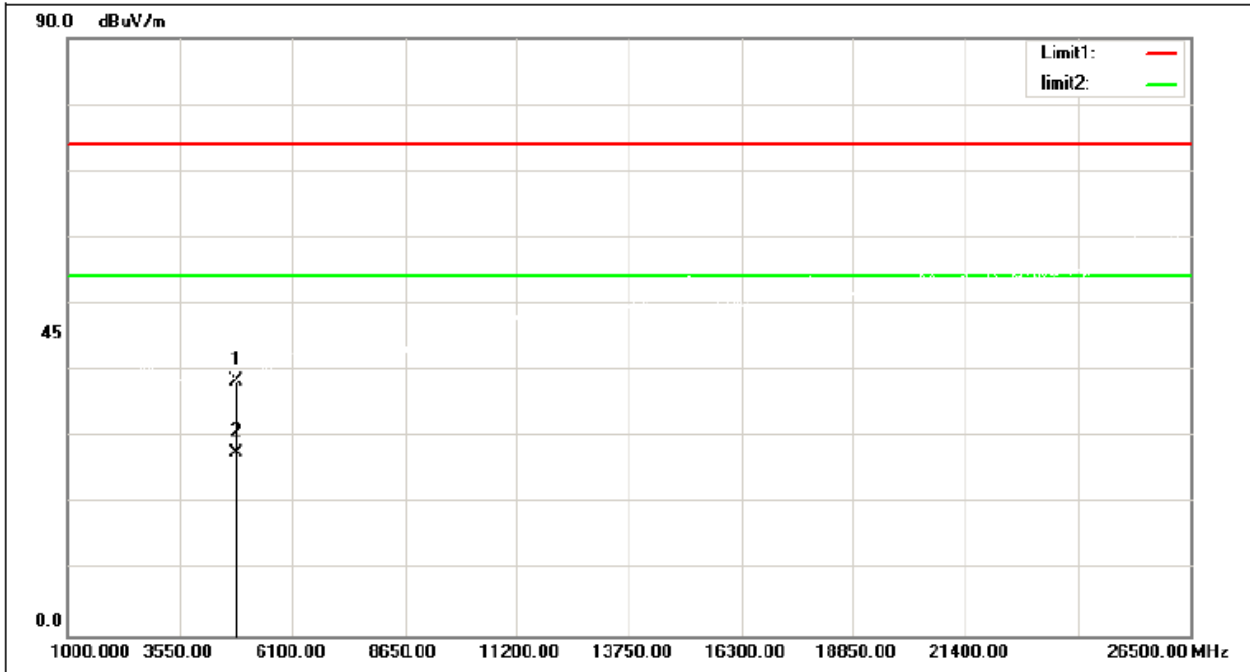

No.	Frequency (MHz)	Reading (dBuV/m)	Correct Factor(dB/m)	Result (dBuV/m)	Limit (dBuV/m)	Margin (dB)	Remark
1	4824.000	47.63	-9.20	38.43	74.00	-35.57	peak
2	4824.000	36.83	-9.20	27.63	54.00	-26.37	AVG

Orthogonal Axis	X
Test Mode:	TX B Mode 2412 MHz

Horizontal

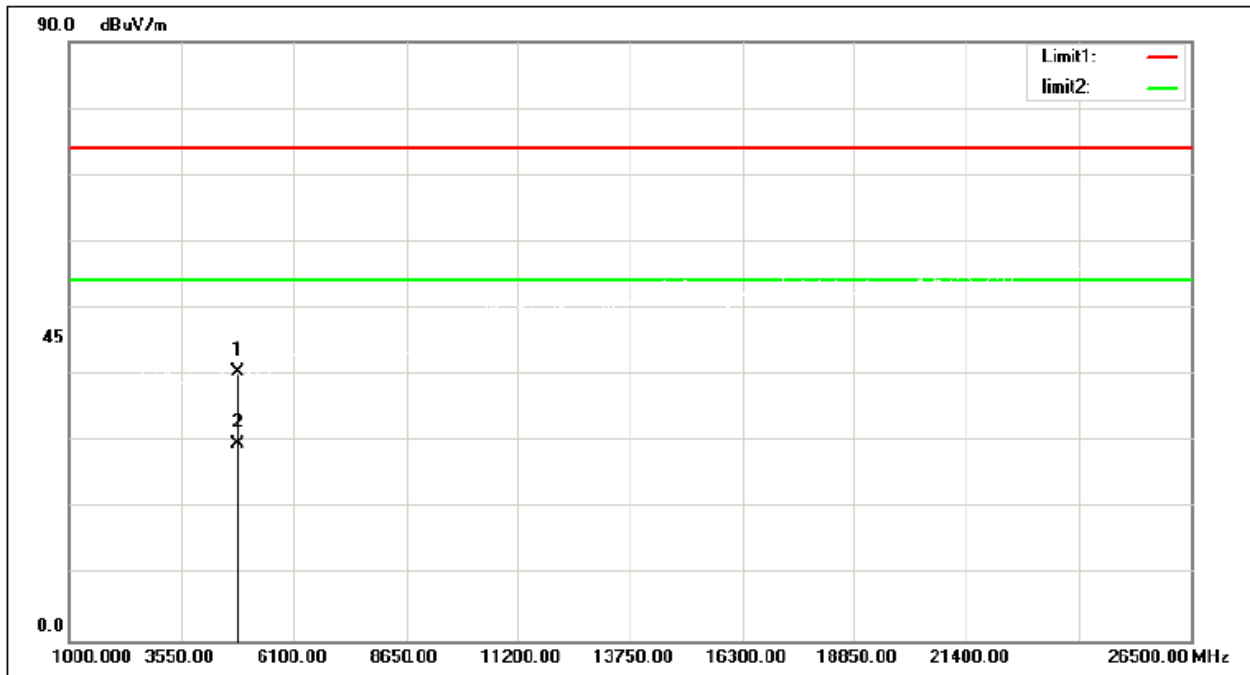

No.	Frequency (MHz)	Reading (dBuV/m)	Correct Factor(dB/m)	Result (dBuV/m)	Limit (dBuV/m)	Margin (dB)	Remark
1	4824.000	49.62	-9.20	40.42	74.00	-33.58	peak
2	4824.000	38.85	-9.20	29.65	54.00	-24.35	AVG

Orthogonal Axis	X
Test Mode:	TX B Mode 2437 MHz

Vertical

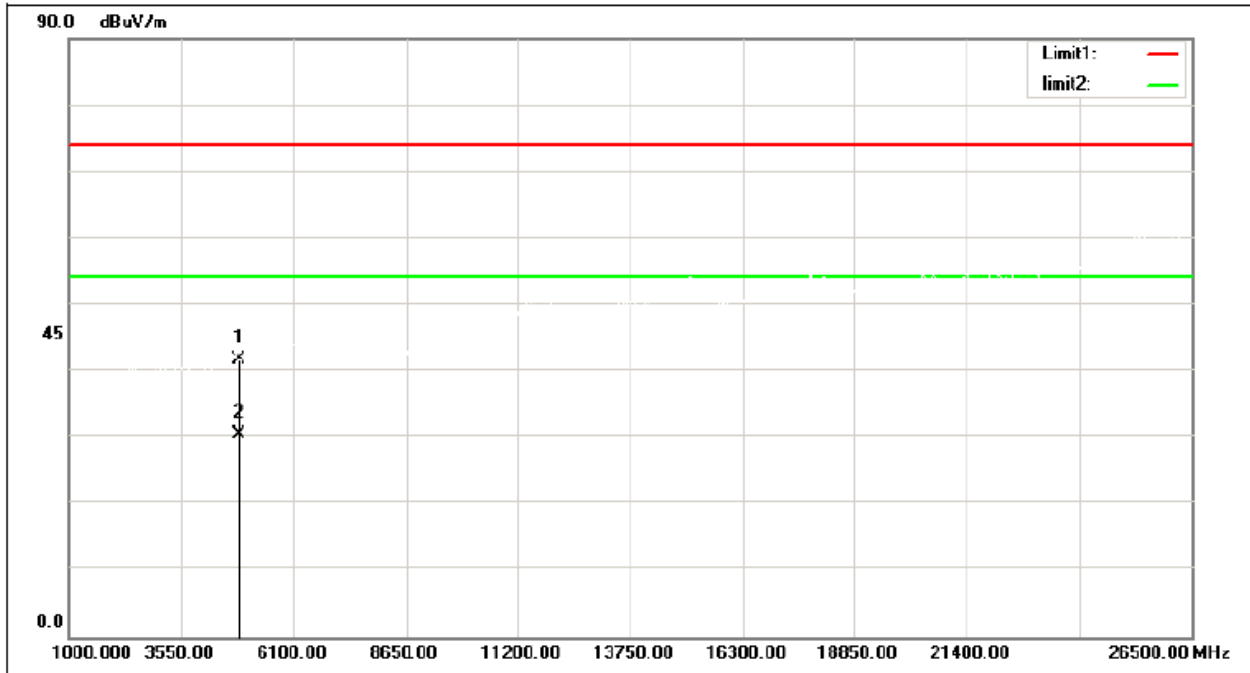

No.	Frequency (MHz)	Reading (dBuV/m)	Correct Factor (dB/m)	Result (dBuV/m)	Limit (dBuV/m)	Margin (dB)	Remark
1	4874.000	50.72	-9.05	41.67	74.00	-32.33	peak
2	4874.000	39.53	-9.05	30.48	54.00	-23.52	AVG

Orthogonal Axis	X
Test Mode:	TX B Mode 2437 MHz

Horizontal

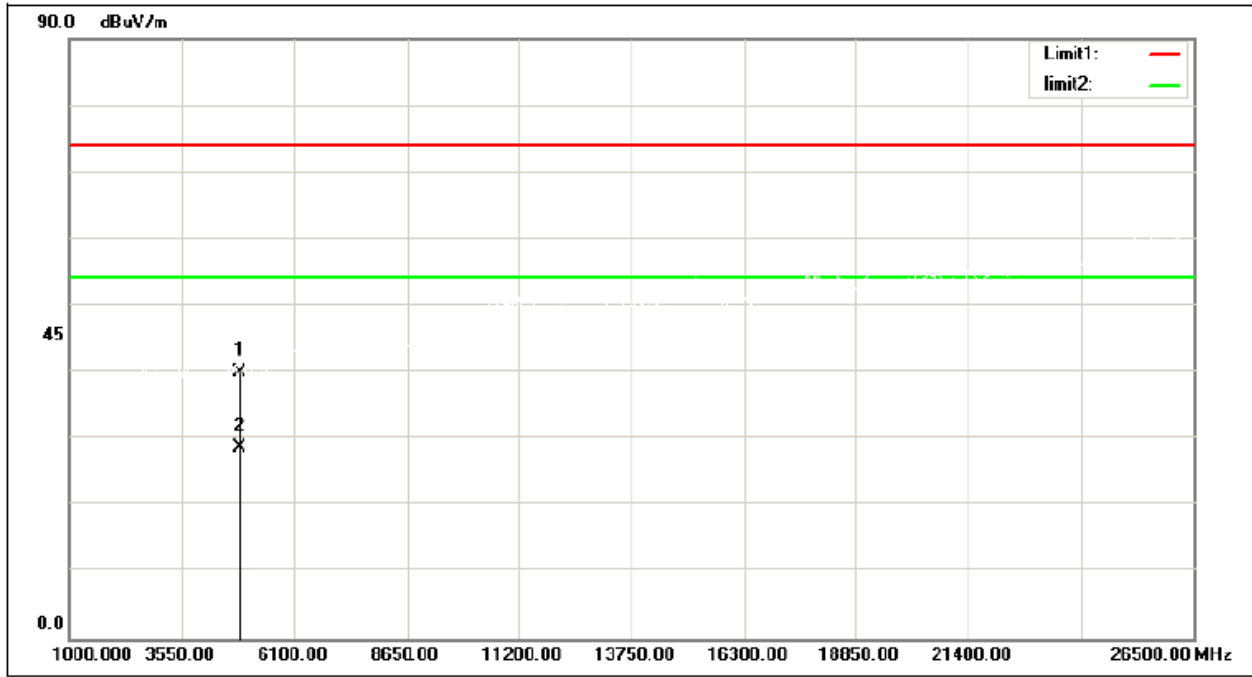

No.	Frequency (MHz)	Reading (dBuV/m)	Correct Factor(dB/m)	Result (dBuV/m)	Limit (dBuV/m)	Margin (dB)	Remark
1	4874.000	48.95	-9.05	39.90	74.00	-34.10	peak
2	4874.000	37.69	-9.05	28.64	54.00	-25.36	AVG

Orthogonal Axis	X
Test Mode:	TX B Mode 2462 MHz

Vertical

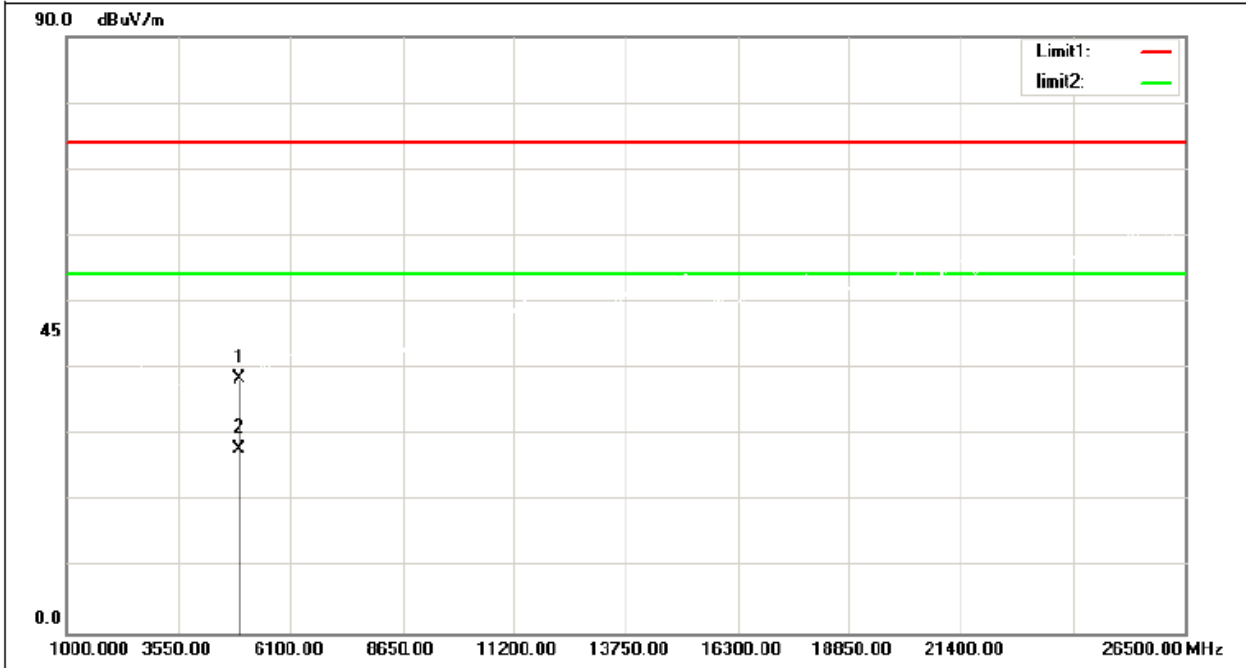

No.	Frequency (MHz)	Reading (dBuV/m)	Correct Factor(dB/m)	Result (dBuV/m)	Limit (dBuV/m)	Margin (dB)	Remark
1	4924.000	47.27	-8.90	38.37	74.00	-35.63	peak
2	4924.000	36.59	-8.90	27.69	54.00	-26.31	AVG

Orthogonal Axis	X
Test Mode:	TX B Mode 2462 MHz

Horizontal

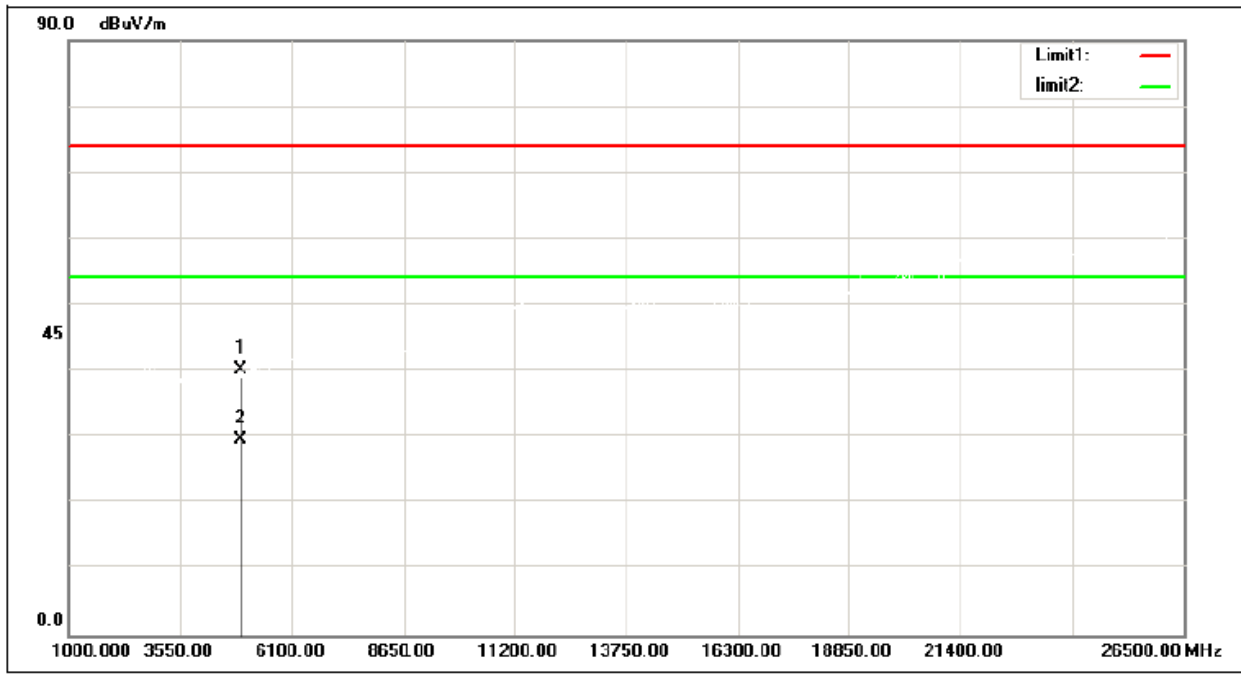

No.	Frequency (MHz)	Reading (dBuV/m)	Correct Factor (dB/m)	Result (dBuV/m)	Limit (dBuV/m)	Margin (dB)	Remark
1	4924.000	49.09	-8.90	40.19	74.00	-33.81	peak
2	4924.000	38.38	-8.90	29.48	54.00	-24.52	AVG

Orthogonal Axis	X
Test Mode:	TX G Mode 2412 MHz

Vertical

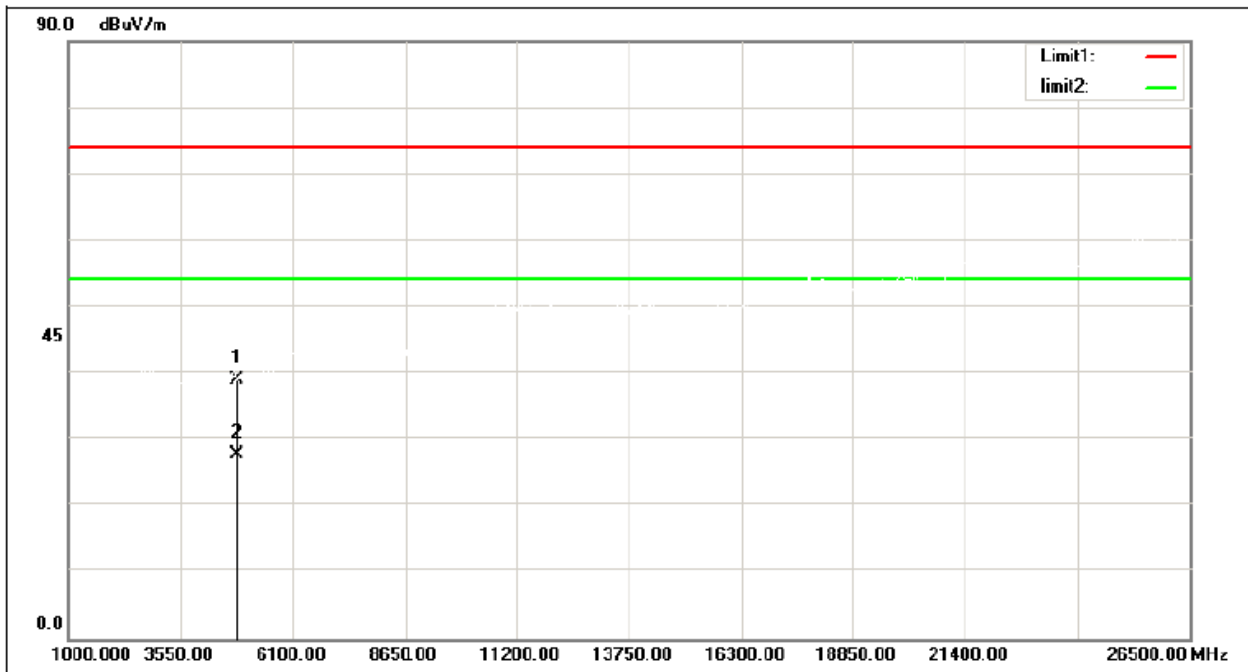

No.	Frequency (MHz)	Reading (dBuV/m)	Correct Factor(dB/m)	Result (dBuV/m)	Limit (dBuV/m)	Margin (dB)	Remark
1	4824.000	48.13	-9.20	38.93	74.00	-35.07	peak
2	4824.000	36.95	-9.20	27.75	54.00	-26.25	AVG

Orthogonal Axis	X
Test Mode:	TX G Mode 2412 MHz

Horizontal

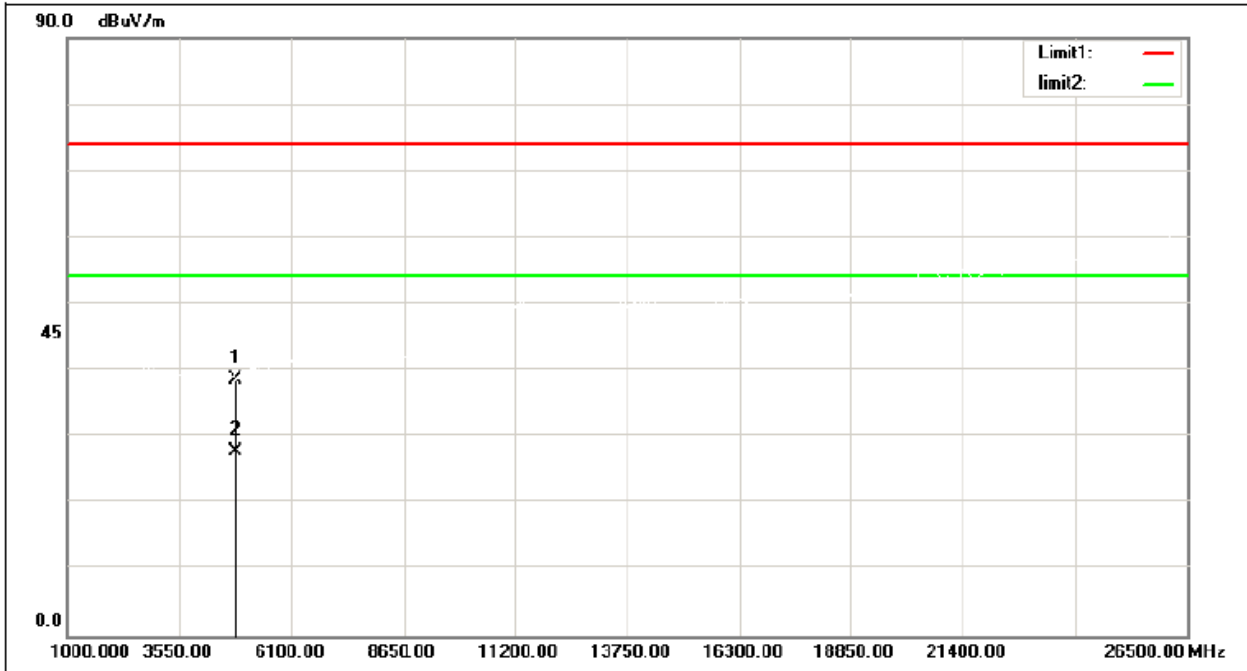

No.	Frequency (MHz)	Reading (dBuV/m)	Correct Factor (dB/m)	Result (dBuV/m)	Limit (dBuV/m)	Margin (dB)	Remark
1	4824.000	47.89	-9.20	38.69	74.00	-35.31	peak
2	4824.000	37.05	-9.20	27.85	54.00	-26.15	AVG

Orthogonal Axis	X
Test Mode:	TX G Mode 2437 MHz

Vertical

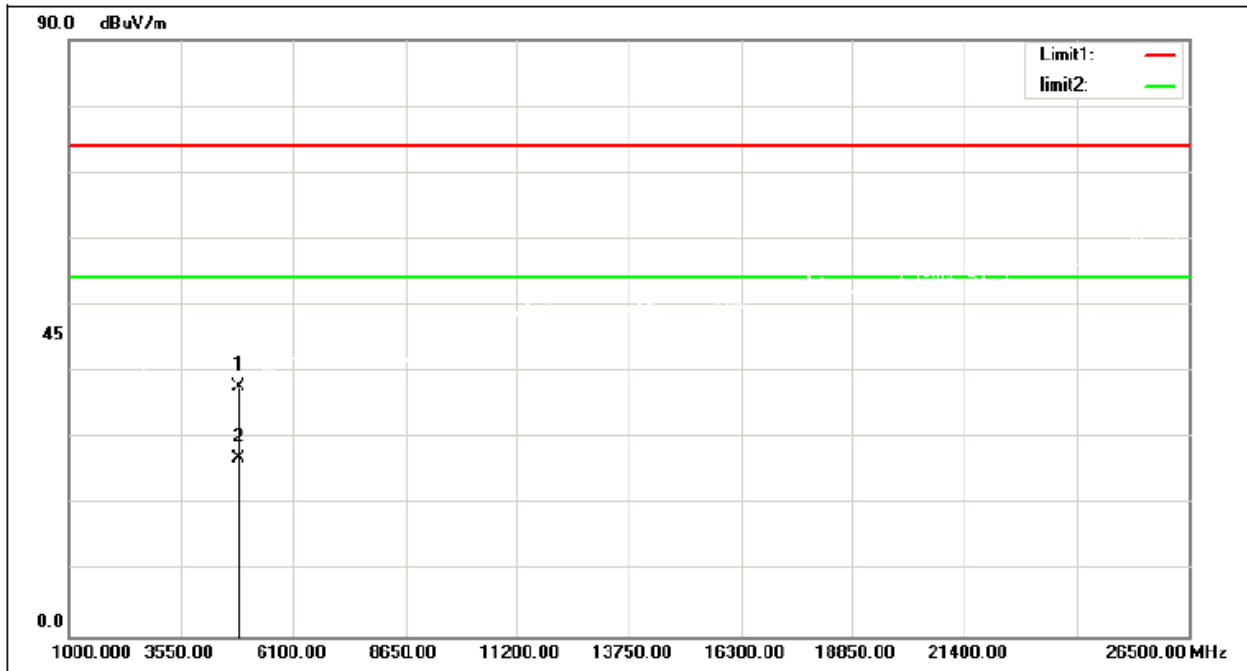

No.	Frequency (MHz)	Reading (dBuV/m)	Correct Factor(dB/m)	Result (dBuV/m)	Limit (dBuV/m)	Margin (dB)	Remark
1	4874.000	46.72	-9.05	37.67	74.00	-36.33	peak
2	4874.000	35.96	-9.05	26.91	54.00	-27.09	AVG

Orthogonal Axis	X
Test Mode:	TX G Mode 2437 MHz

Horizontal

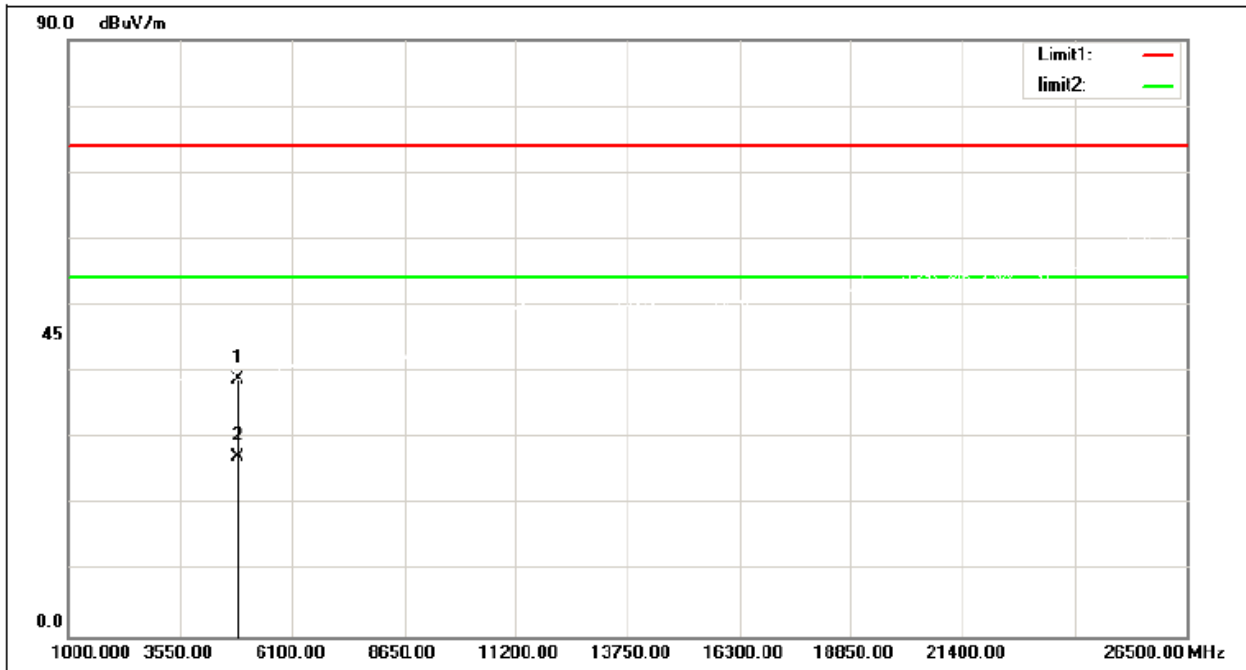

No.	Frequency (MHz)	Reading (dBuV/m)	Correct Factor (dB/m)	Result (dBuV/m)	Limit (dBuV/m)	Margin (dB)	Remark
1	4874.000	47.95	-9.05	38.90	74.00	-35.10	peak
2	4874.000	36.23	-9.05	27.18	54.00	-26.82	AVG

Orthogonal Axis	X
Test Mode:	TX G Mode 2462 MHz

Vertical

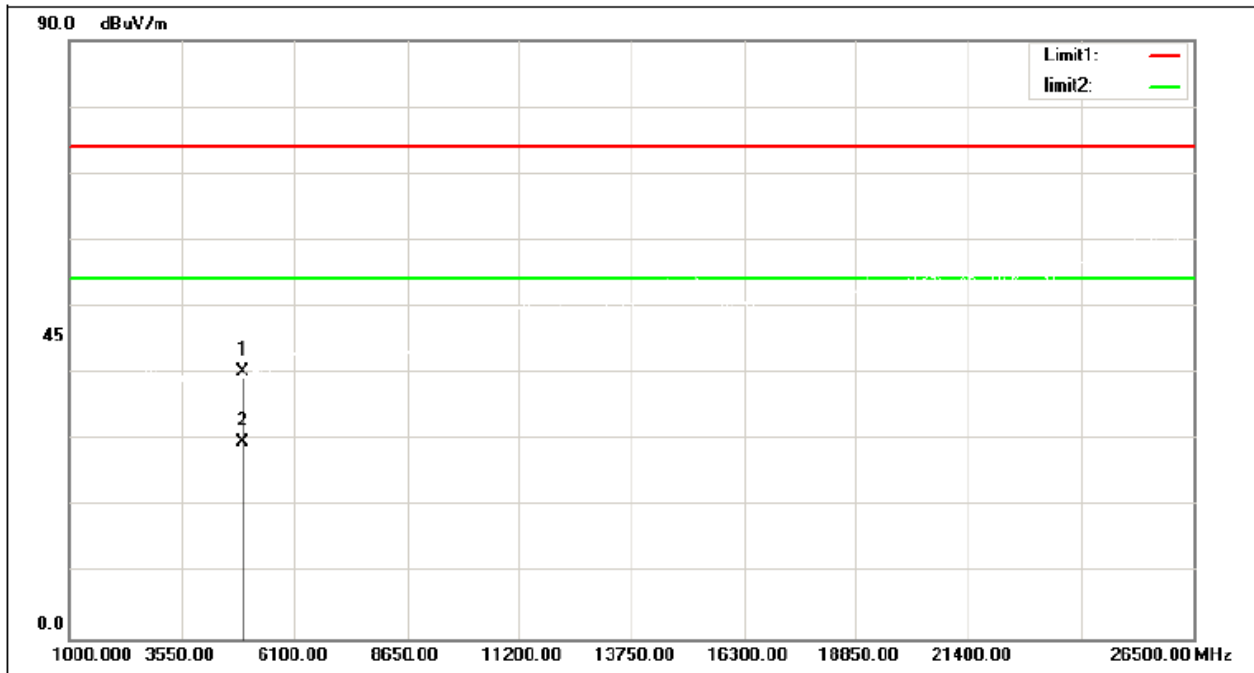

No.	Frequency (MHz)	Reading (dBuV/m)	Correct Factor(dB/m)	Result (dBuV/m)	Limit (dBuV/m)	Margin (dB)	Remark
1	4924.000	49.09	-8.90	40.19	74.00	-33.81	peak
2	4924.000	38.58	-8.90	29.68	54.00	-24.32	AVG

Orthogonal Axis	X
Test Mode:	TX G Mode 2462 MHz

Horizontal

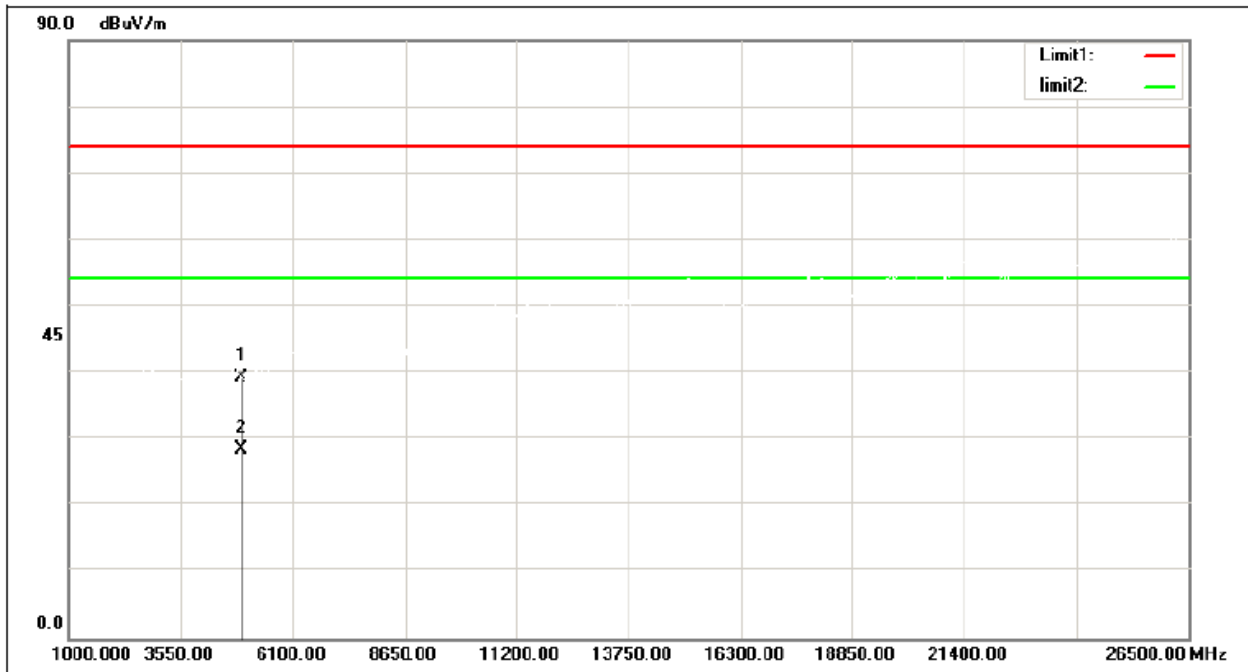

No.	Frequency (MHz)	Reading (dBuV/m)	Correct Factor(dB/m)	Result (dBuV/m)	Limit (dBuV/m)	Margin (dB)	Remark
1	4924.000	48.27	-8.90	39.37	74.00	-34.63	peak
2	4924.000	37.37	-8.90	28.47	54.00	-25.53	AVG

Orthogonal Axis	X
Test Mode:	TX N-20M Mode 2412 MHz

Vertical

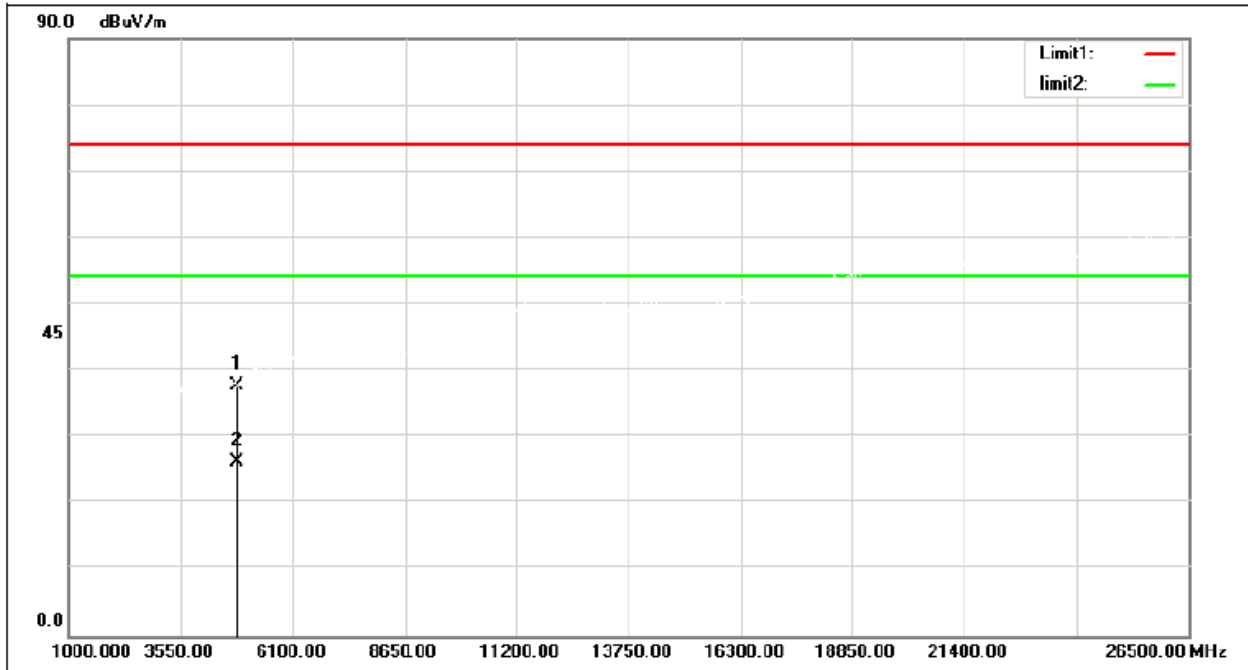

No.	Frequency (MHz)	Reading (dBuV/m)	Correct Factor(dB/m)	Result (dBuV/m)	Limit (dBuV/m)	Margin (dB)	Remark
1	4824.000	46.89	-9.20	37.69	74.00	-36.31	peak
2	4824.000	35.39	-9.20	26.19	54.00	-27.81	AVG

Orthogonal Axis	X
Test Mode:	TX N-20M Mode 2412 MHz

Horizontal

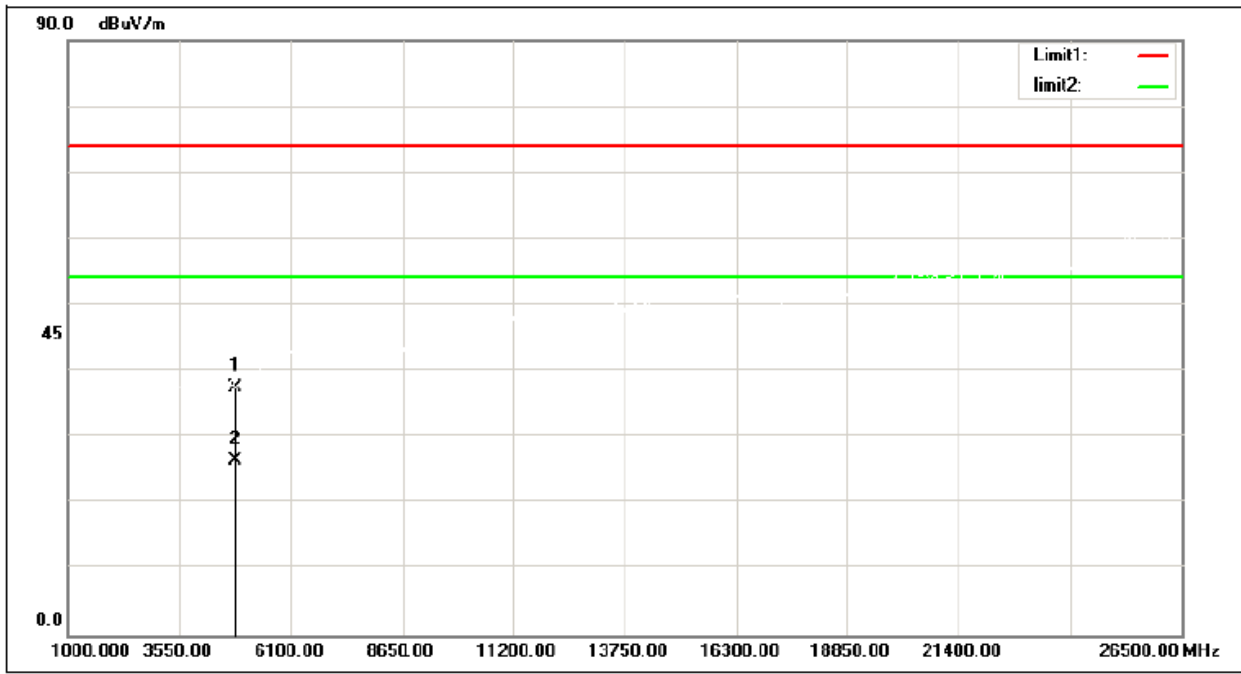

No.	Frequency (MHz)	Reading (dBuV/m)	Correct Factor (dB/m)	Result (dBuV/m)	Limit (dBuV/m)	Margin (dB)	Remark
1	4824.000	46.63	-9.20	37.43	74.00	-36.57	peak
2	4824.000	35.69	-9.20	26.49	54.00	-27.51	AVG

Orthogonal Axis	X
Test Mode:	TX N-20M Mode 2437 MHz

Vertical

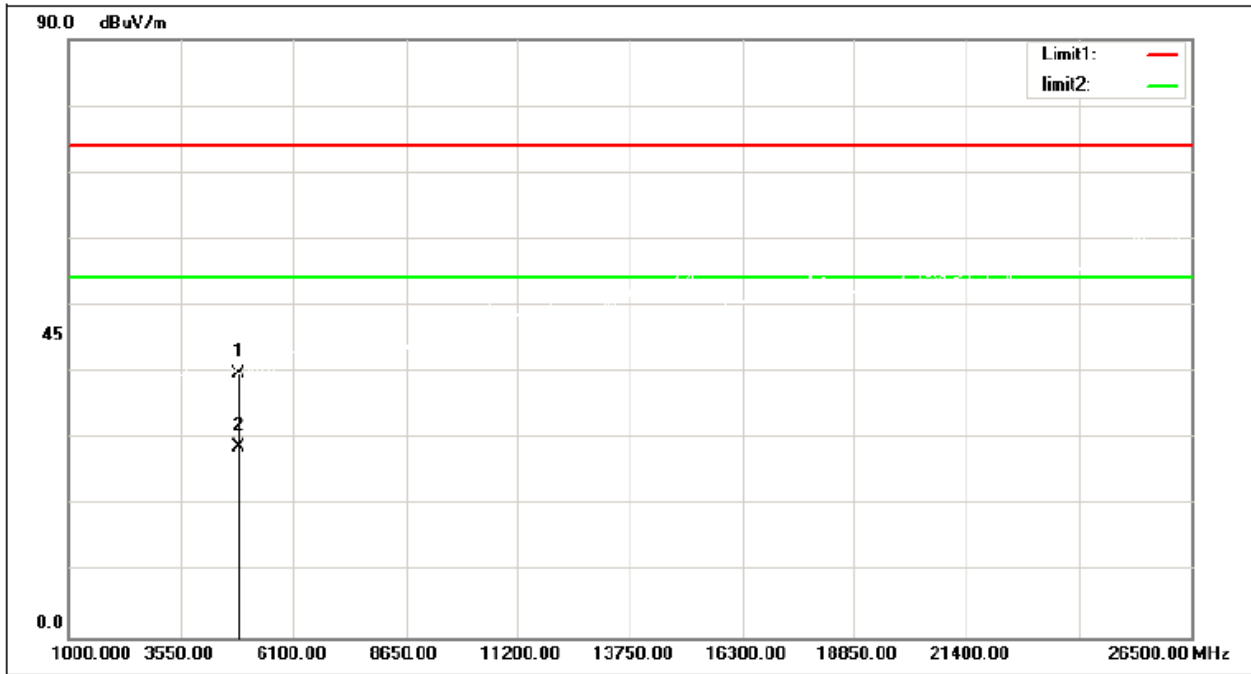

No.	Frequency (MHz)	Reading (dBuV/m)	Correct Factor(dB/m)	Result (dBuV/m)	Limit (dBuV/m)	Margin (dB)	Remark
1	4874.000	48.72	-9.05	39.67	74.00	-34.33	peak
2	4874.000	37.66	-9.05	28.61	54.00	-25.39	AVG

Orthogonal Axis	X
Test Mode:	TX N-20M Mode 2437 MHz

Horizontal

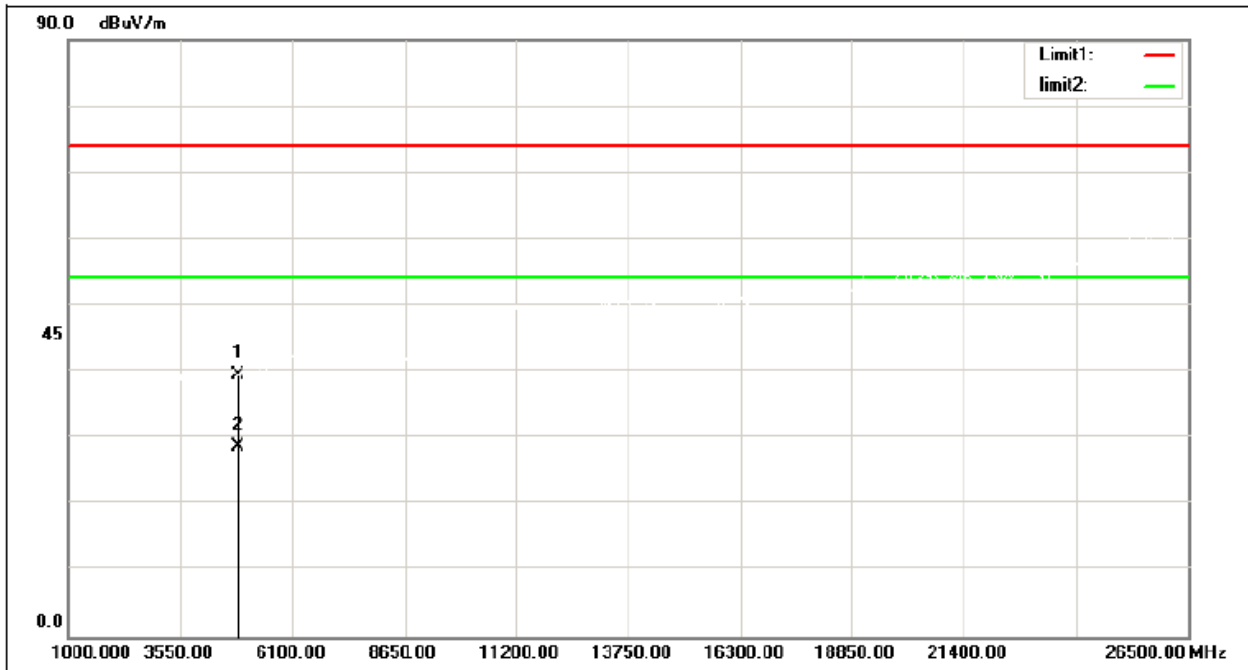

No.	Frequency (MHz)	Reading (dBuV/m)	Correct Factor(dB/m)	Result (dBuV/m)	Limit (dBuV/m)	Margin (dB)	Remark
1	4874.000	48.45	-9.05	39.40	74.00	-34.60	peak
2	4874.000	37.72	-9.05	28.67	54.00	-25.33	AVG

Orthogonal Axis	X
Test Mode:	TX N-20M Mode 2462 MHz

Vertical

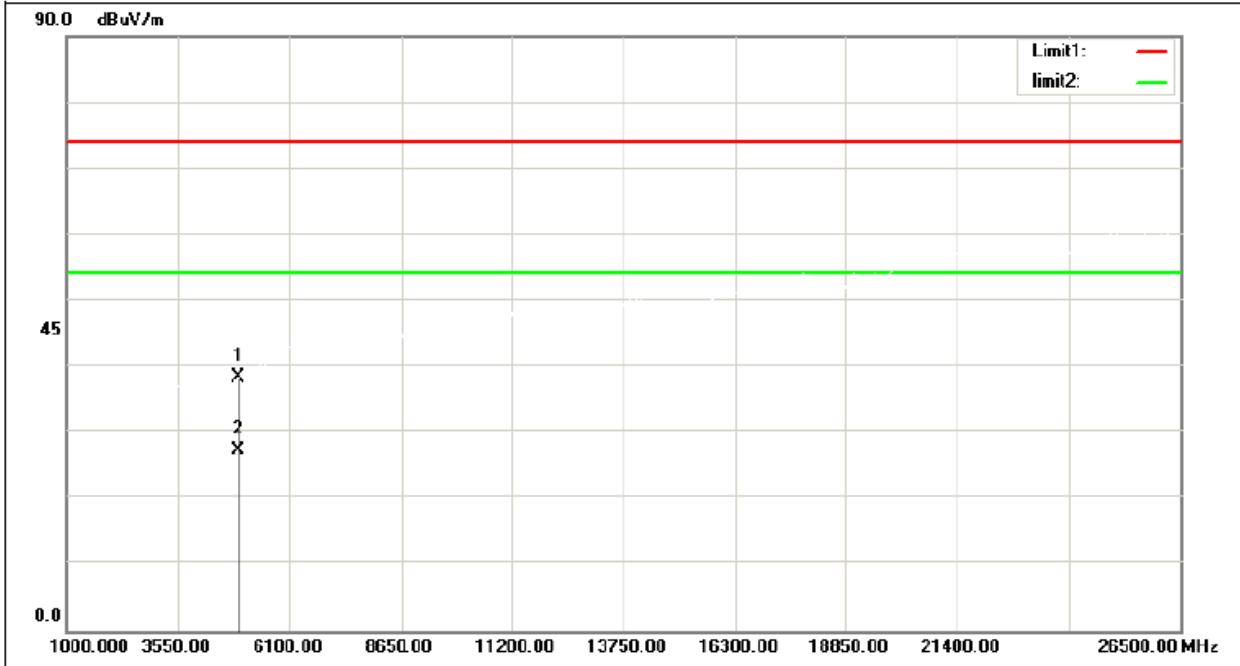

No.	Frequency (MHz)	Reading (dBuV/m)	Correct Factor(dB/m)	Result (dBuV/m)	Limit (dBuV/m)	Margin (dB)	Remark
1	4924.000	47.27	-8.90	38.37	74.00	-35.63	peak
2	4924.000	36.18	-8.90	27.28	54.00	-26.72	AVG

Orthogonal Axis	X
Test Mode:	TX N-20M Mode 2462 MHz

Horizontal

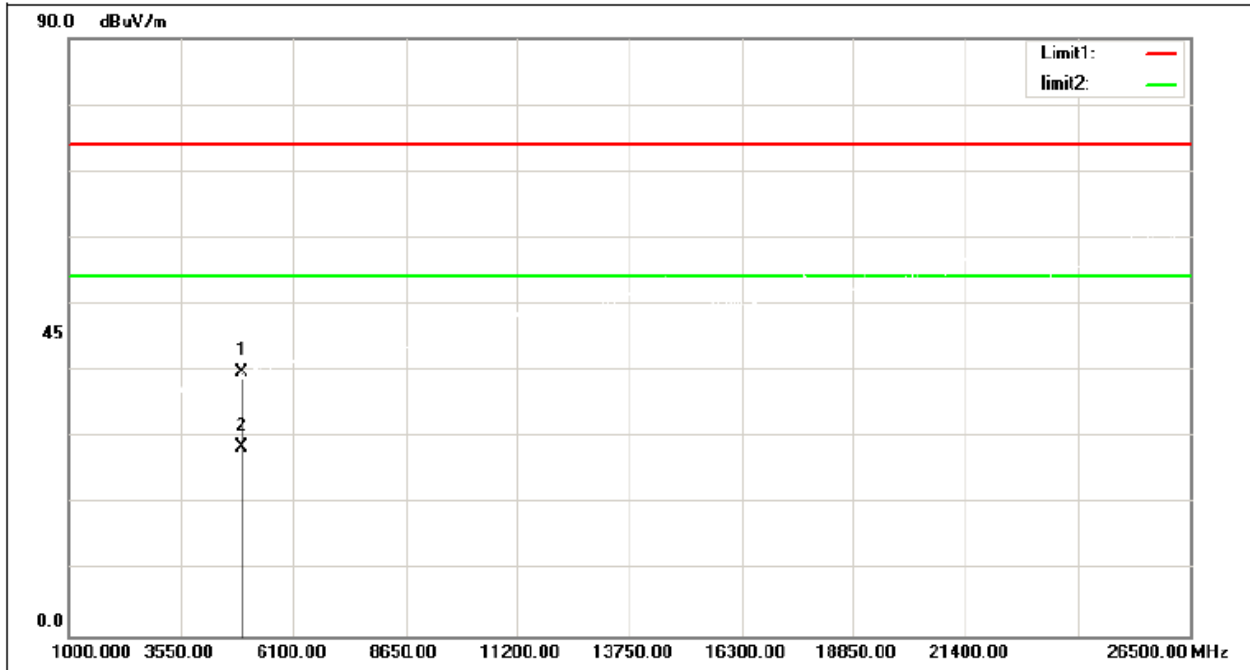

No.	Frequency (MHz)	Reading (dBuV/m)	Correct Factor(dB/m)	Result (dBuV/m)	Limit (dBuV/m)	Margin (dB)	Remark
1	4924.000	48.59	-8.90	39.69	74.00	-34.31	peak
2	4924.000	37.26	-8.90	28.36	54.00	-25.64	AVG

Orthogonal Axis	X
Test Mode:	TX N-40M Mode 2422MHz

Vertical

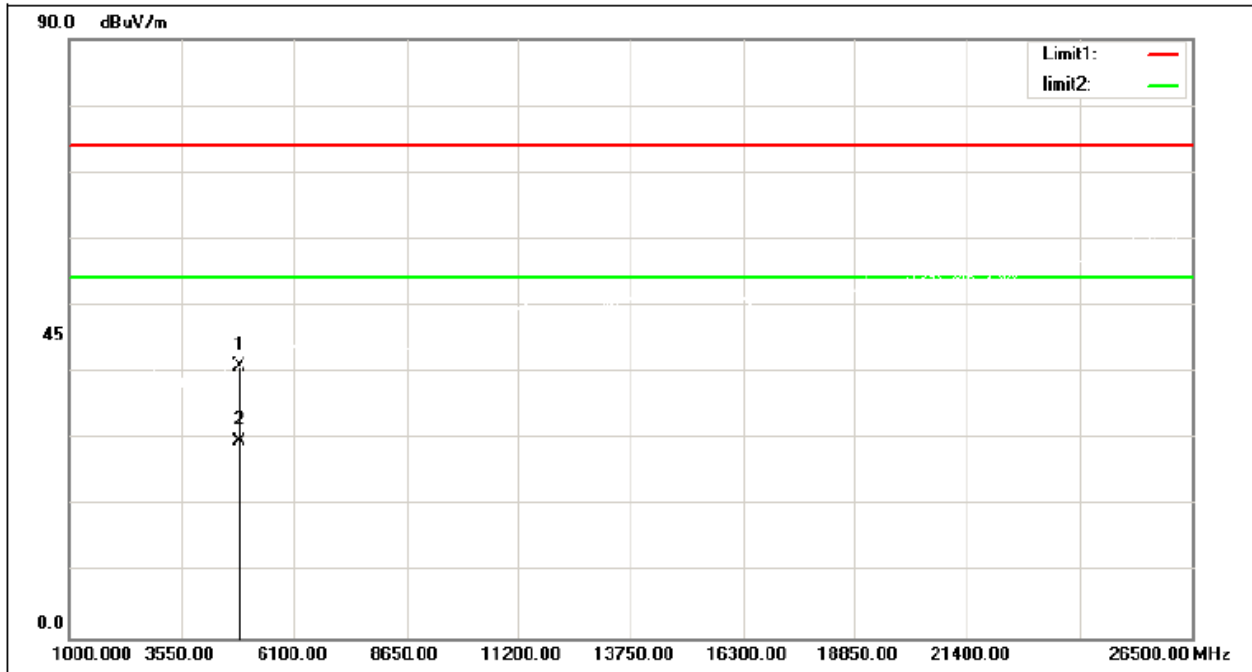

No.	Frequency (MHz)	Reading (dBuV/m)	Correct Factor(dB/m)	Result (dBuV/m)	Limit (dBuV/m)	Margin (dB)	Remark
1	4844.000	50.04	-9.14	40.90	74.00	-33.10	peak
2	4844.000	38.62	-9.14	29.48	54.00	-24.52	AVG

Orthogonal Axis	X
Test Mode:	TX N-40M Mode 2422MHz

Horizontal

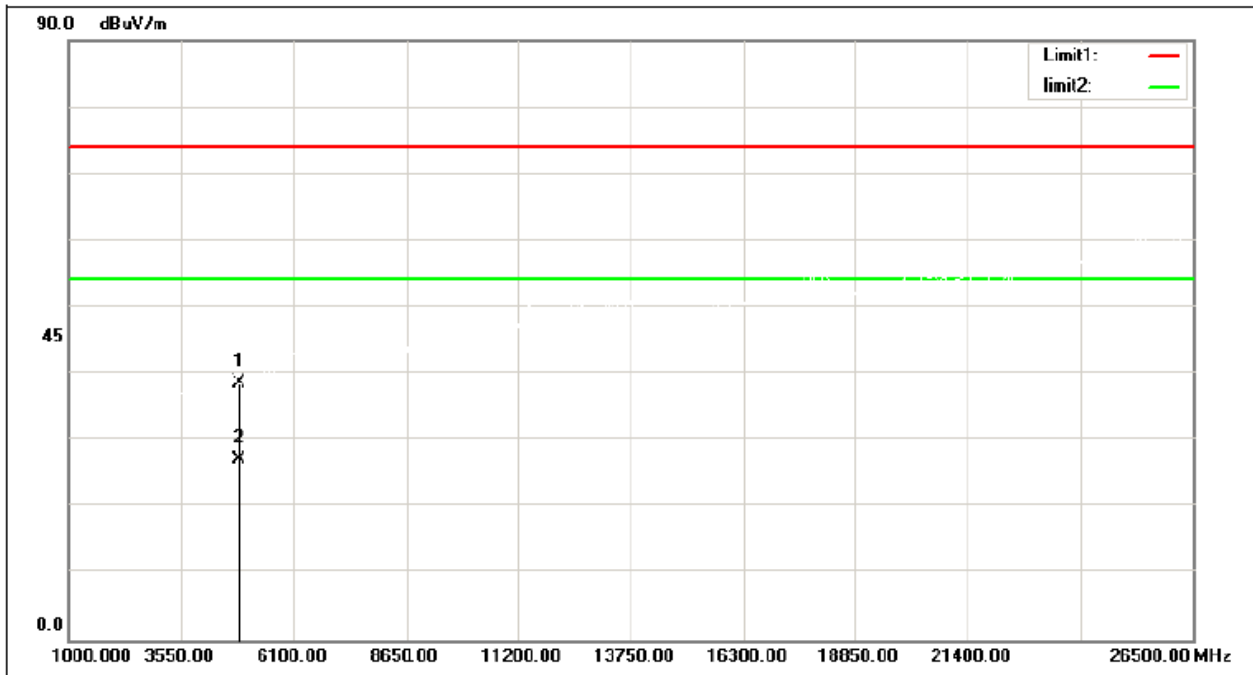

No.	Frequency (MHz)	Reading (dBuV/m)	Correct Factor(dB/m)	Result (dBuV/m)	Limit (dBuV/m)	Margin (dB)	Remark
1	4844.000	47.81	-9.14	38.67	74.00	-35.33	peak
2	4844.000	36.29	-9.14	27.15	54.00	-26.85	AVG

Orthogonal Axis	X
Test Mode:	TX N-40M Mode 2437 MHz

Vertical

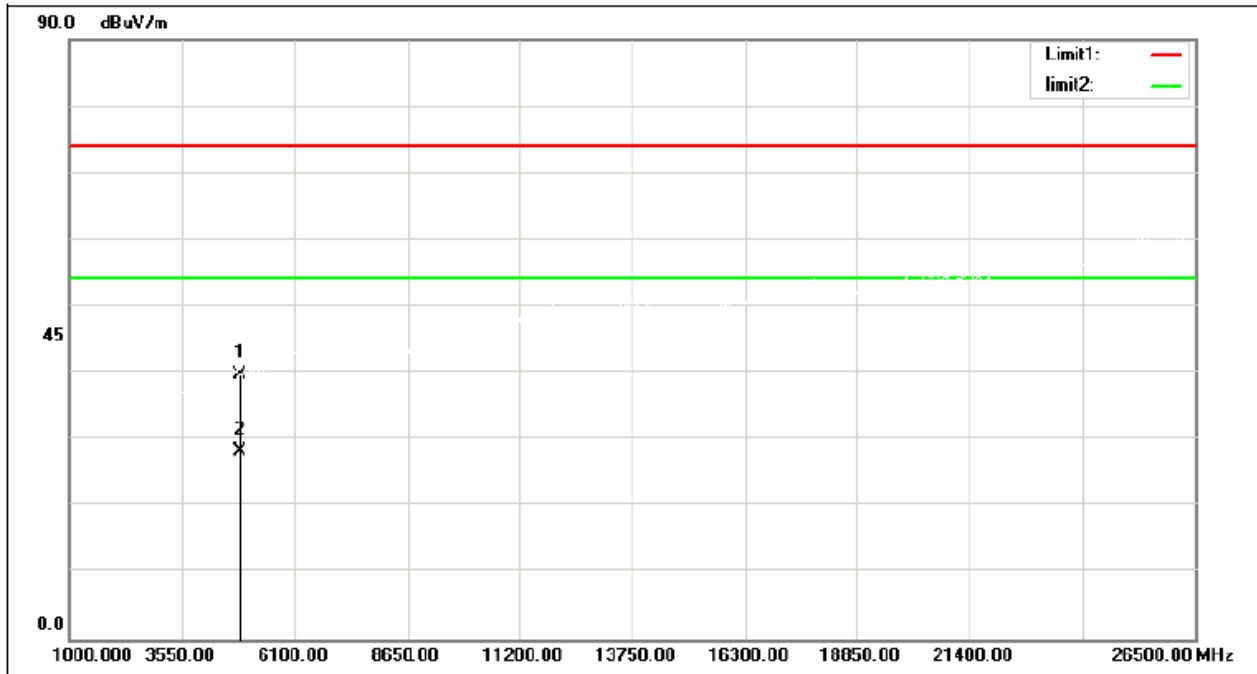

No.	Frequency (MHz)	Reading (dBuV/m)	Correct Factor(dB/m)	Result (dBuV/m)	Limit (dBuV/m)	Margin (dB)	Remark
1	4874.000	48.72	-9.05	39.67	74.00	-34.33	peak
2	4874.000	37.20	-9.05	28.15	54.00	-25.85	AVG

Orthogonal Axis	X
Test Mode:	TX N-40M Mode 2437 MHz

Horizontal

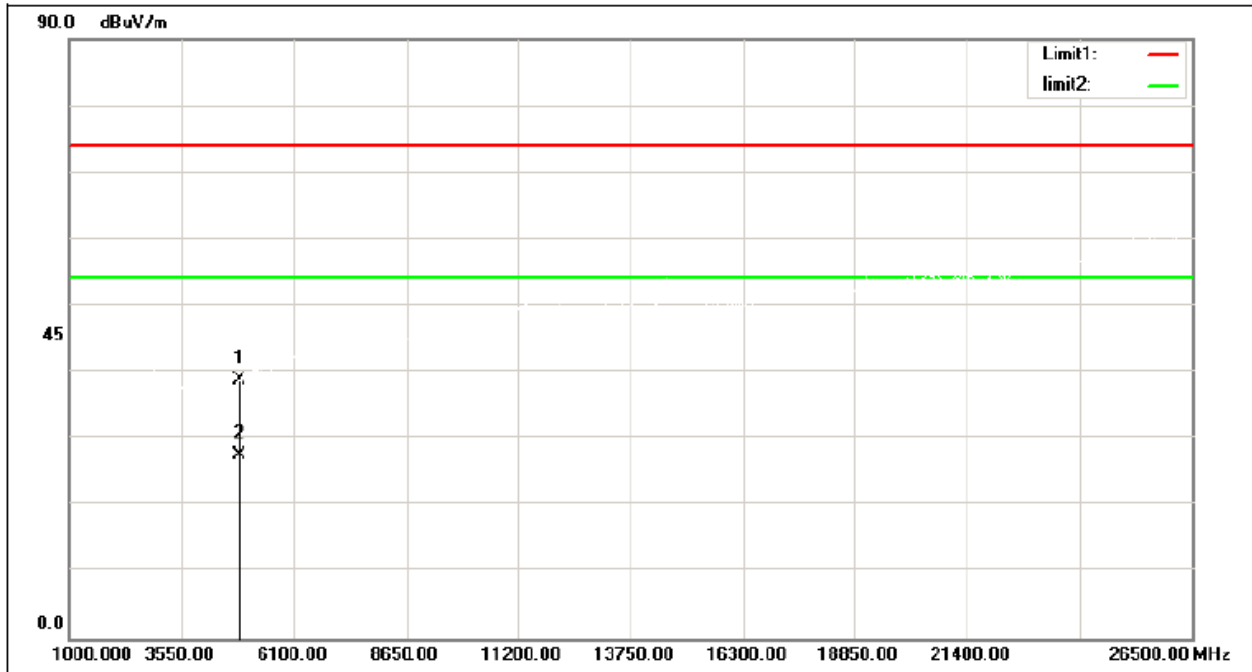

No.	Frequency (MHz)	Reading (dBuV/m)	Correct Factor(dB/m)	Result (dBuV/m)	Limit (dBuV/m)	Margin (dB)	Remark
1	4874.000	47.95	-9.05	38.90	74.00	-35.10	peak
2	4874.000	36.68	-9.05	27.63	54.00	-26.37	AVG

Orthogonal Axis	X
Test Mode:	TX N-40M Mode 2452 MHz

Vertical

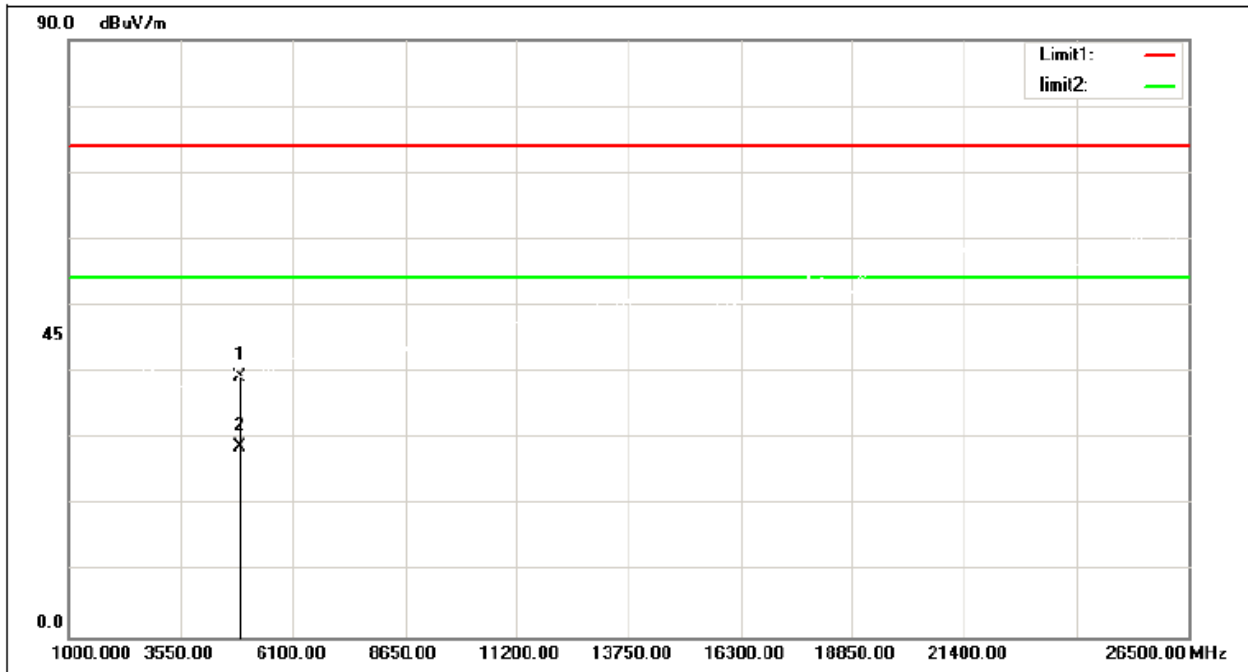

No.	Frequency (MHz)	Reading (dBuV/m)	Correct Factor (dB/m)	Result (dBuV/m)	Limit (dBuV/m)	Margin (dB)	Remark
1	4904.000	48.33	-8.96	39.37	74.00	-34.63	peak
2	4904.000	37.65	-8.96	28.69	54.00	-25.31	AVG

Orthogonal Axis	X
Test Mode:	TX N-40M Mode 2452 MHz

Horizontal

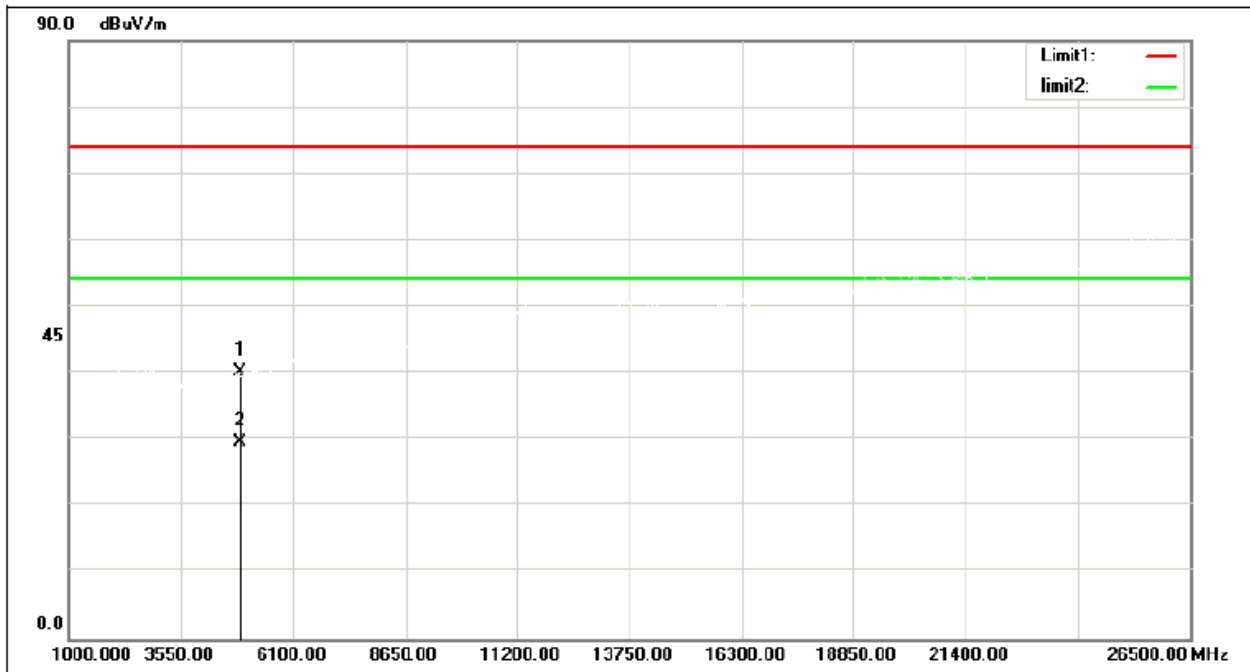

No.	Frequency (MHz)	Reading (dBuV/m)	Correct Factor(dB/m)	Result (dBuV/m)	Limit (dBuV/m)	Margin (dB)	Remark
1	4904.000	49.15	-8.96	40.19	74.00	-33.81	peak
2	4904.000	38.64	-8.96	29.68	54.00	-24.32	AVG

6 BANDWIDTH TEST

6.1 LIMIT

FCC Part15, Subpart C (15.247)&RSS-Gen and RSS-247		
Section	Test Item	Limit
15.247(a)(2) RSS-Gen6.7 RSS-247 5.2 (a)	6dB Bandwidth	Minimum 500 kHz
	99% Emission Bandwidth	-

6.2 TEST PROCEDURE AND SETTING

- The EUT was directly connected to the spectrum analyzer and antenna output port as show in the block diagram below.
- For 6dB Bandwidth Spectrum setting:RBW= 100KHz, VBW=300KHz, Sweep time = 2.5ms.
For 99% OBW Spectrum Setting: RBW= 300KHz, VBW=1MHz,Sweep time = 2.5ms.
- The bandwidth was performed in accordance with method 11.8.1 of ANSI C63.10-2013.

6.3 MEASUREMENT INSTRUMENTS LIST

Item	Kind of Equipment	Manufacturer	Type No.	Serial No.	Calibrated until
1	Spectrum analyzer	KEYSIGHT	N9010A	MY55150427	2022/05/28
2	Attenuator	Mini-Circuits	BW-S10W2	101109	N/A
3	RF Cable	Mi-cable	C10-01-01-1	100309	N/A

6.4 TEST SETUP



6.5 EUT OPERATION CONDITIONS

The EUT tested system was configured as the statements of 4.5 unless otherwise a special operating condition is specified in the follows during the testing.

6.6 TEST RESULTS

TX B Mode					
Channel	Frequency (MHz)	6dB Bandwidth (MHz)	99% Emission Bandwidth (MHz)	6dB Bandwidth Min. Limit (kHz)	Result
01	2412	9.055	13.379	500	PASS
06	2437	9.058	13.380	500	PASS
11	2462	8.581	13.382	500	PASS

6dB

CH01

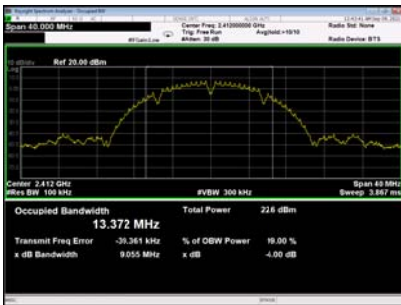

CH06

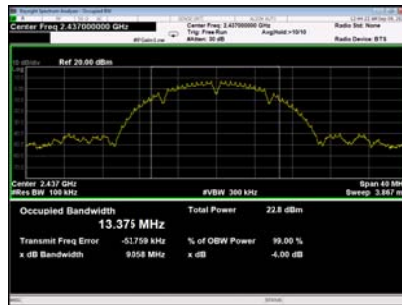

CH11

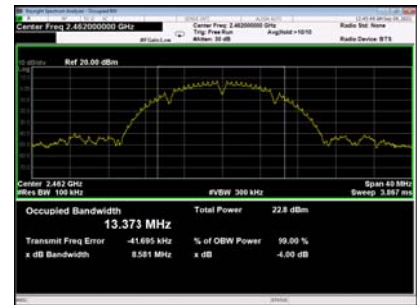

99%

CH01

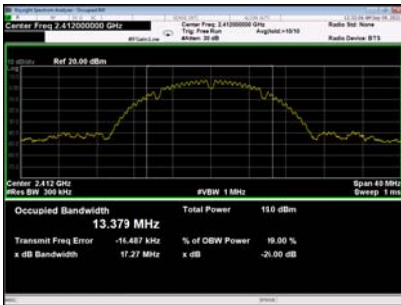

CH06

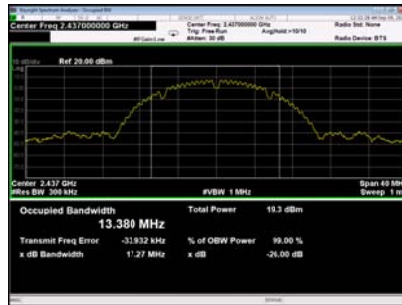

CH11

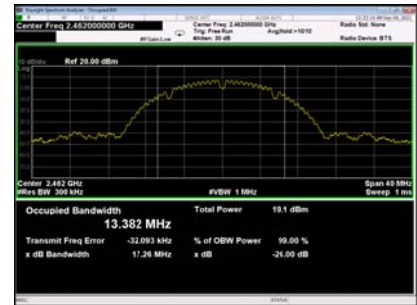

TX G Mode					
Channel	Frequency (MHz)	6dB Bandwidth (MHz)	99% Emission Bandwidth (MHz)	6dB Bandwidth Min. Limit(kHz)	Result
01	2412	15.07	16.645	500	PASS
06	2437	15.12	16.711	500	PASS
11	2462	15.32	16.787	500	PASS

6dB

CH01

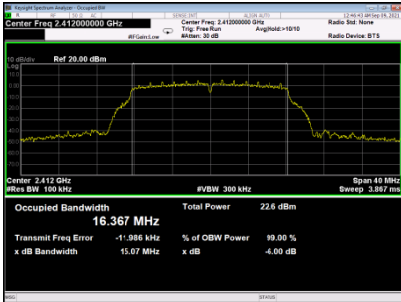

CH06

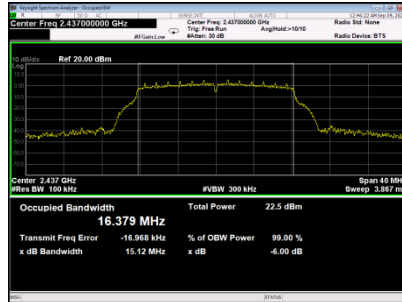

CH11

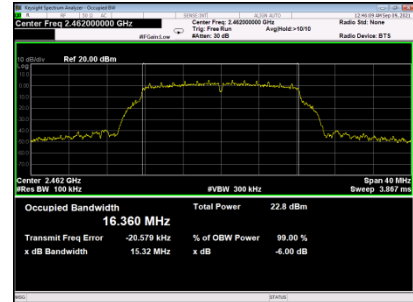

99%

CH01

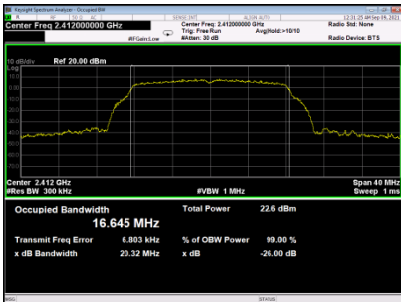

CH06

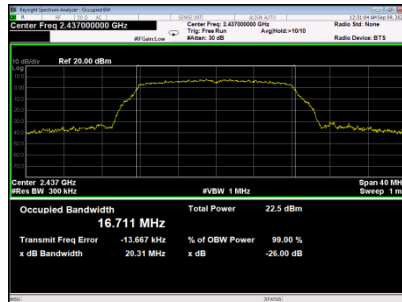

CH11

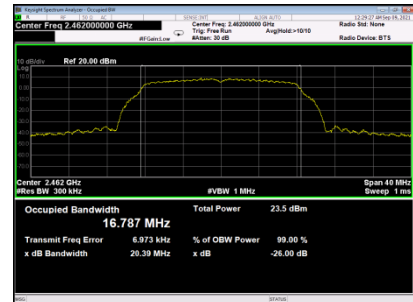

TX N (HT20) Mode					
Channel	Frequency (MHz)	6dB Bandwidth (MHz)	99% Emission Bandwidth (MHz)	6dB Bandwidth Min. Limit(kHz)	Result
01	2412	15.15	17.680	500	PASS
06	2437	15.15	17.666	500	PASS
11	2462	15.17	17.699	500	PASS

6dB

CH01

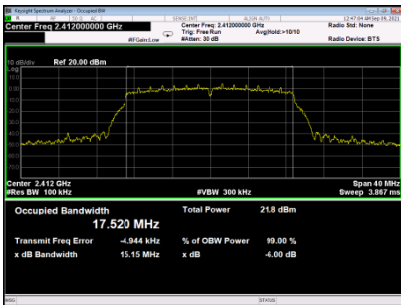

CH06

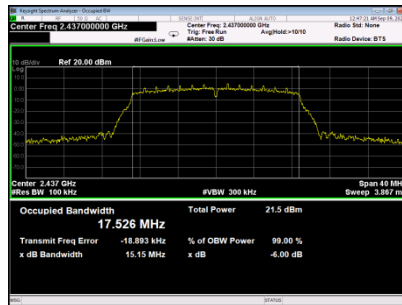

CH11

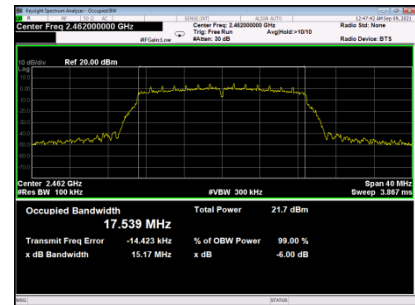

99%

CH01

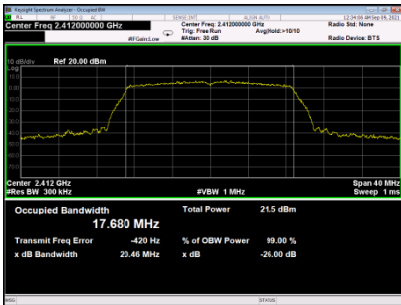

CH06

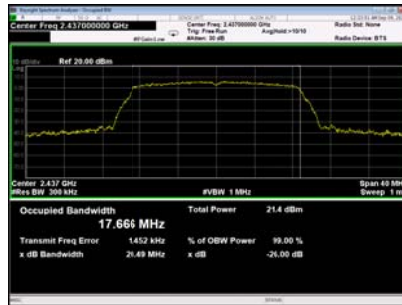

CH11

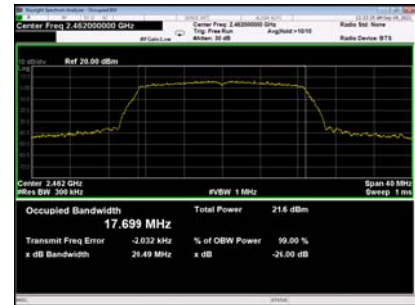

TX N (HT40) Mode					
Channel	Frequency (MHz)	6dB Bandwidth (MHz)	99% Emission Bandwidth (MHz)	6dB Bandwidth Min. Limit(kHz)	Result
03	2422	35.18	36.296	500	PASS
06	2437	35.14	36.264	500	PASS
09	2452	35.16	36.528	500	PASS

6dB

CH03

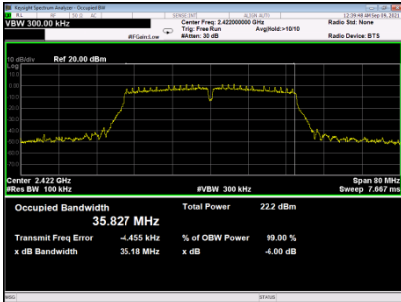

CH06

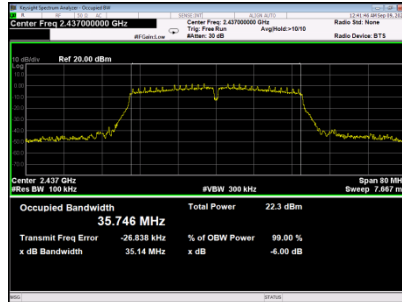

CH09

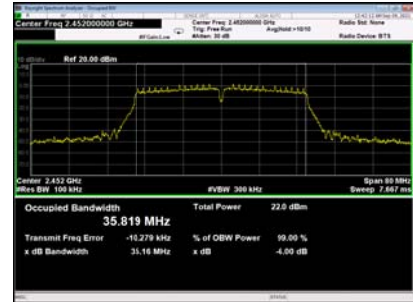

99%

CH03

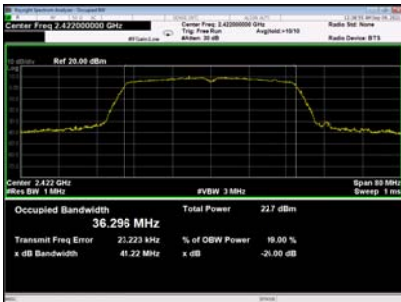

CH06

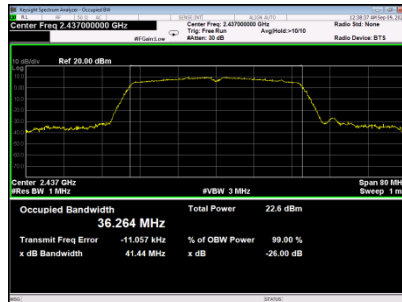

CH9

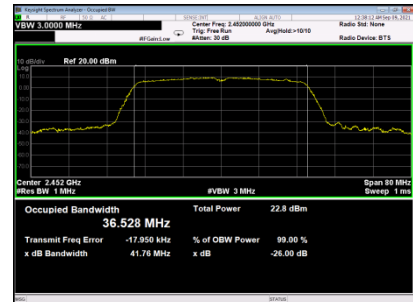

7 MAXIMUM OUTPUT POWER TEST

7.1 LIMIT

FCC Part15, Subpart C (15.247)&RSS-247		
Section	Test Item	Limit
15.247(b)(3) RSS-2475.4 (d)	Maximum Output Power	1 Watt or 30dBm

7.2 TEST PROCEDURE AND SETTING

- The EUT was directly connected to the power meter and antenna output port as show in the block diagram below.
- The maximum conducted output power was performed in accordance with method 11.9.1.3 of ANSI C63.10-2013.and FCC KDB 662911 D01 v02r01 Multiple Transmitter Output.

7.3 MEASUREMENT INSTRUMENTS LIST

Item	Equipment	Manufacturer	Model No.	Serial No.	Calibrated until
1	Power Sensor	KEYSIGHT	U2021XA	MY55240009	05/23/2022
2	Attenuator	Mini-Circuits	BW-S10W2	101109	N/A
3	RF Cable	Micable	C10-01-01-1	100309	N/A
4	Test Software	KEYSIGHT	Power Panel	V3.11	N/A

7.4 TEST SETUP

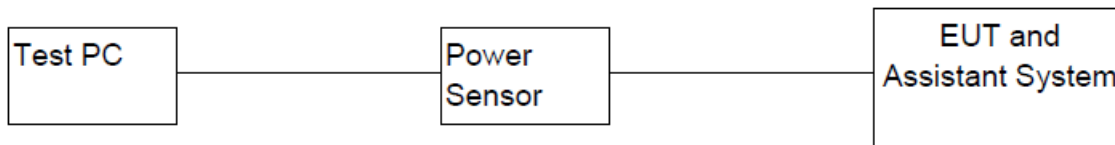

7.5 EUT OPERATION CONDITIONS

The EUT tested system was configured as the statements of 4.5 unless otherwise a special operating condition is specified in the follows during the testing.

7.6 TEST RESULTS

TX BMode_Ant 1				
Channel	Frequency (MHz)	Output Power (dBm)	Output Power (W)	Result
01	2412	16.93	0.0493	PASS
06	2437	17.26	0.0532	PASS
11	2462	17.08	0.0511	PASS
Limit	30dBm / 1W			

TX BMode_Ant 2				
Channel	Frequency (MHz)	Output Power (dBm)	Output Power (W)	Result
01	2412	17.04	0.0506	PASS
06	2437	17.46	0.0557	PASS
11	2462	17.50	0.0562	PASS
Limit	30dBm / 1W			

TX GMode_Ant 1				
Channel	Frequency (MHz)	Output Power (dBm)	Output Power (W)	Result
01	2412	20.88	0.1225	PASS
06	2437	20.78	0.1197	PASS
11	2462	20.83	0.1211	PASS
Limit	30dBm / 1W			

TX GMode_Ant 2				
Channel	Frequency (MHz)	Output Power (dBm)	Output Power (W)	Result
01	2412	20.25	0.1059	PASS
06	2437	20.25	0.1059	PASS
11	2462	20.99	0.1256	PASS
Limit	30dBm / 1W			

TX N (HT20) _Ant 1				
Channel	Frequency (MHz)	Output Power (dBm)	Output Power (W)	Result
01	2412	19.34	0.0859	PASS
06	2437	19.25	0.0841	PASS
11	2462	19.22	0.0836	PASS
Limit	30dBm / 1W			

TX N (HT20) _Ant 2				
Channel	Frequency (MHz)	Output Power (dBm)	Output Power (W)	Result
01	2412	20.60	0.1148	PASS
06	2437	20.13	0.1030	PASS
11	2462	20.61	0.1151	PASS
Limit	30dBm / 1W			

TX N (HT20) _Total				
Channel	Frequency (MHz)	Output Power (dBm)	Output Power (W)	Result
01	2412	23.03	0.2007	PASS
06	2437	22.72	0.1872	PASS
11	2462	22.98	0.1986	PASS
Limit	30dBm / 1W			

TX N (HT40) _Ant 1				
Channel	Frequency (MHz)	Output Power (dBm)	Output Power (W)	Result
03	2422	19.49	0.0889	PASS
06	2437	19.42	0.0875	PASS
09	2452	19.65	0.0923	PASS
Limit	30dBm / 1W			

TX N (HT40) _Ant 2				
Channel	Frequency (MHz)	Output Power (dBm)	Output Power (W)	Result
03	2422	20.89	0.1227	PASS
06	2437	20.69	0.1172	PASS
09	2452	20.76	0.1191	PASS
Limit	30dBm / 1W			

TX N (HT40) _Total				
Channel	Frequency (MHz)	Output Power (dBm)	Output Power (W)	Result
03	2422	23.26	0.2117	PASS
06	2437	23.11	0.2047	PASS
09	2452	23.25	0.2114	PASS
Limit	30dBm / 1W			

8 CONDUCTED SPURIOUS EMISSIONS

8.1 LIMIT

For FCC

In any 100 kHz bandwidth outside the frequency band in which the spread spectrum or digitally modulated intentional radiator is operating, the radio frequency power that is produced by the intentional radiator shall be at least 20 dB below that in the 100 kHz bandwidth within the band that contains the highest level of the desired power, based on either an RF conducted or a radiated measurement, provided the transmitter demonstrates compliance with the peak Output Power limits. If the transmitter complies with the Output Power limits based on the use of RMS averaging over a time interval, as permitted under paragraph (b)(3) of this section, the attenuation required under this paragraph shall be 30 dB instead of 20 dB. Attenuation below the general limits specified in Section 15.209(a) is not required.

For ISSED

In any 100 kHz bandwidth outside the frequency band in which the spread spectrum or digitally modulated device is operating, the RF power that is produced shall be at least 20 dB below that in the 100 kHz bandwidth within the band that contains the highest level of the desired power, based on either an RF conducted or a radiated measurement, provided that the transmitter demonstrates compliance with the peak Output Power limits. If the transmitter complies with the Output Power limits based on the use of root-mean-square averaging over a time interval, as permitted under section 5.4(d), the attenuation required shall be 30 dB instead of 20 dB. Attenuation below the general field strength limits specified in RSS-Gen is not required.

8.2 TEST PROCEDURE AND SETTING

- a. The EUT was directly connected to the spectrum analyzer and antenna output port as show in the block diagram below.
- b. Spectrum Setting: RBW= 100 kHz, VBW=300 kHz, Sweep time = Auto.

8.3 MEASUREMENT INSTRUMENTS LIST

Item	Kind of Equipment	Manufacturer	Type No.	Serial No.	Calibrated until
1	Spectrum analyzer	KEYSIGHT	N9010A	MY55150427	2022/05/28
2	Attenuator	Mini-Circuits	BW-S10W2	101109	N/A
3	RF Cable	Mi-cable	C10-01-01-1	100309	N/A

8.4 TEST SETUP

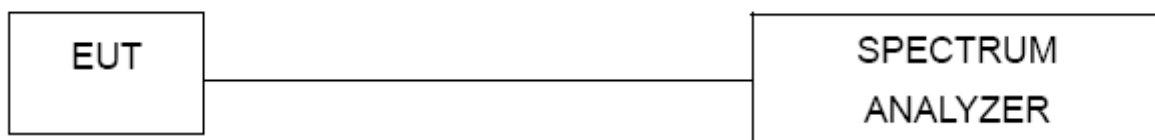

8.5 EUT OPERATION CONDITIONS

The EUT tested system was configured as the statements of 4.5 unless otherwise a special operating condition is specified in the follows during the testing.

8.6 TEST RESULTS

TX B Mode_Ant 1

Bandedge-CH01

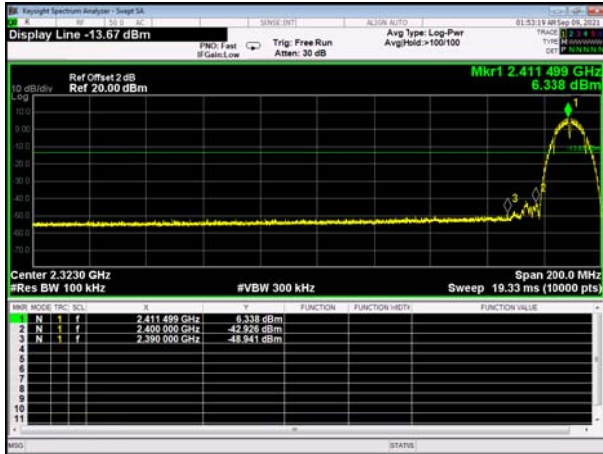

Bandedge-CH11

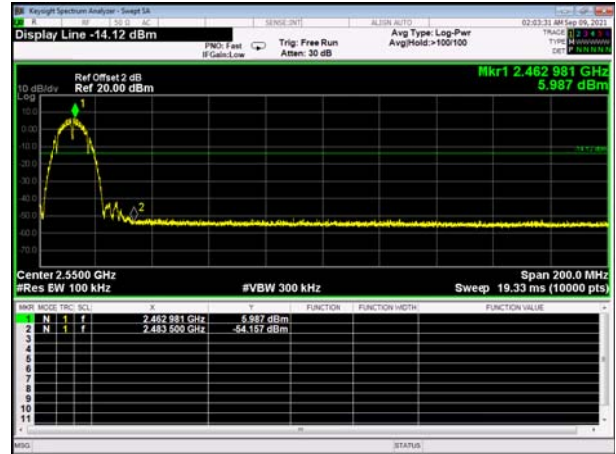

10th Harmonic of the fundamental frequency

CH01

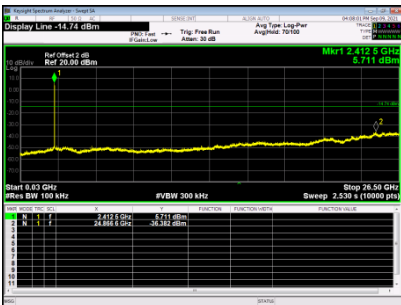

CH06

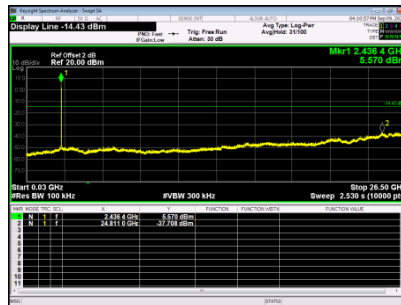

CH11

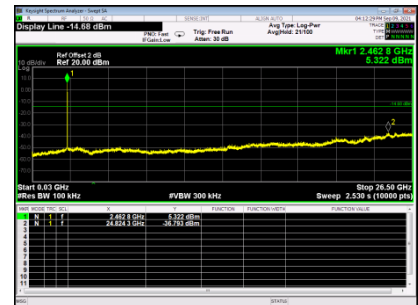

TX GMode_Ant 1

Bandedge-CH01

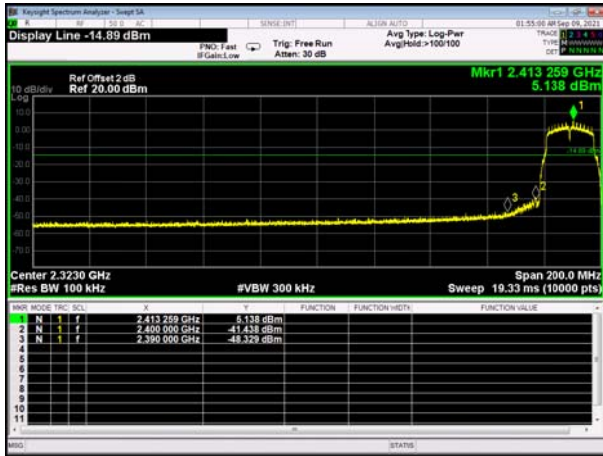

Bandedge-CH11

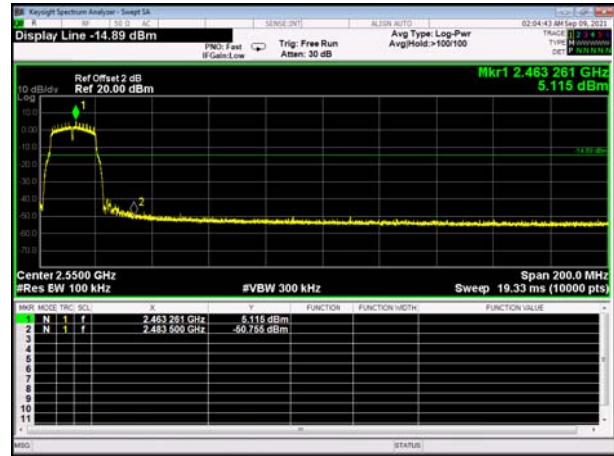

10th Harmonic of the fundamental frequency

CH01

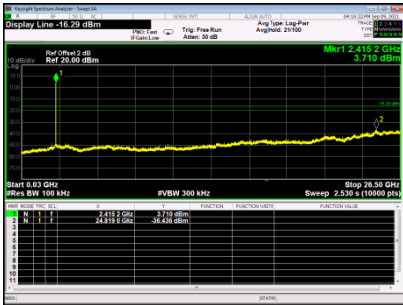

CH06

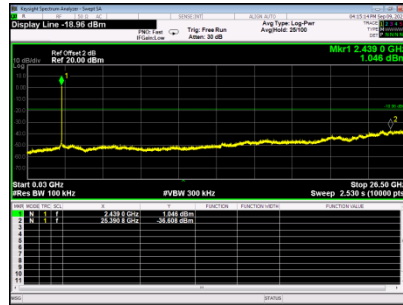

CH11

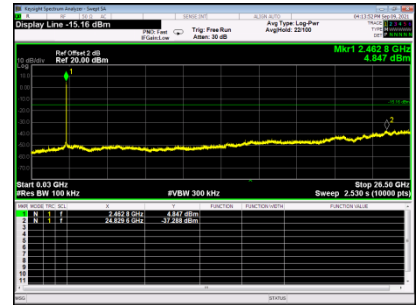

TX N (HT20) Mode _Ant 1

Bandedge-CH01

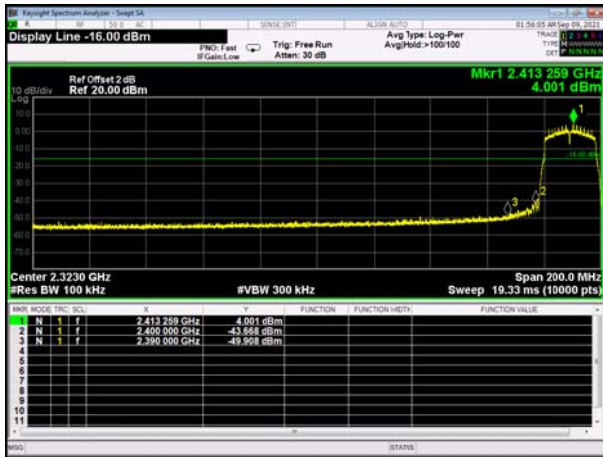

Bandedge-CH11

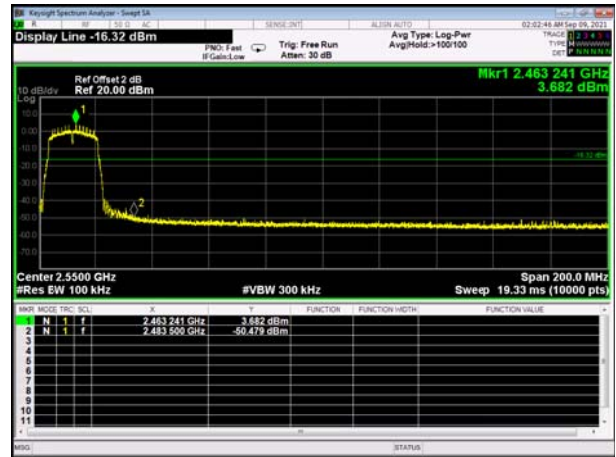

10th Harmonic of the fundamental frequency

CH01

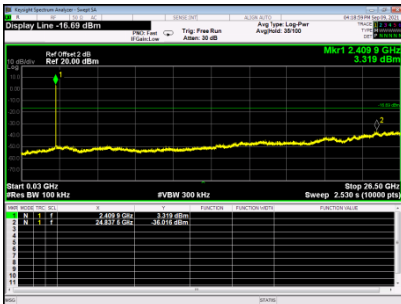

CH06

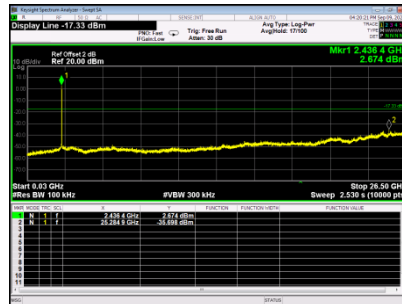

CH11

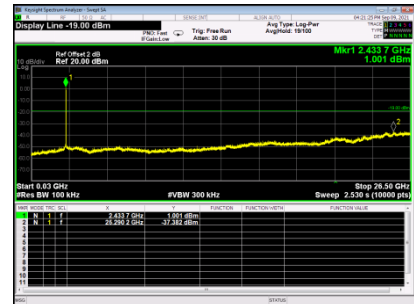

TX N (HT20) Mode _Ant 2

Bandedge-CH01

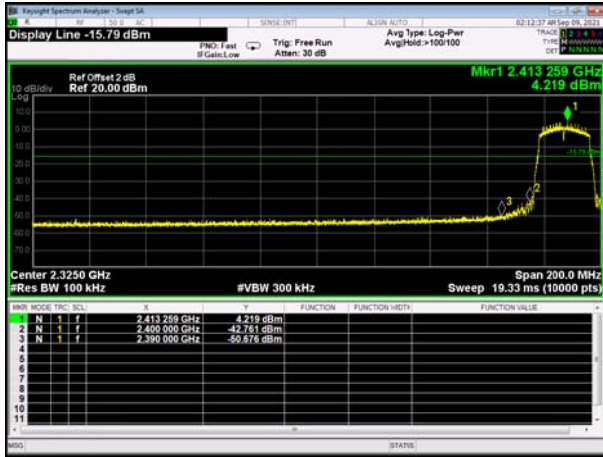

Bandedge-CH11

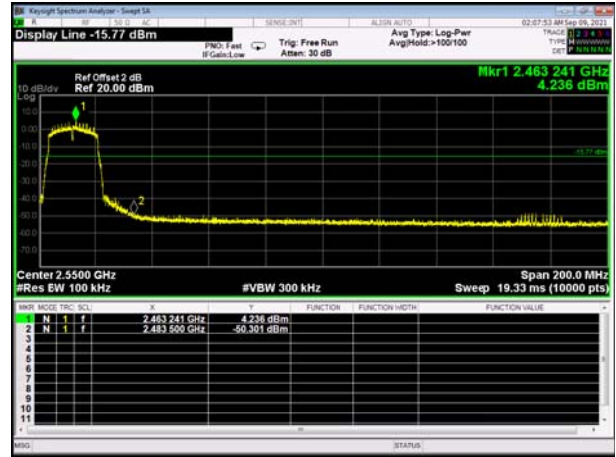

10th Harmonic of the fundamental frequency

CH01

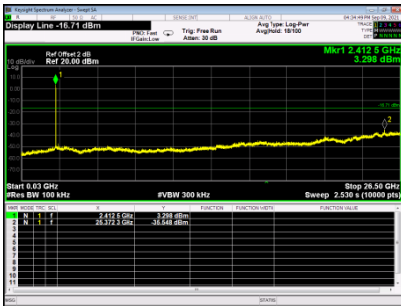

CH06

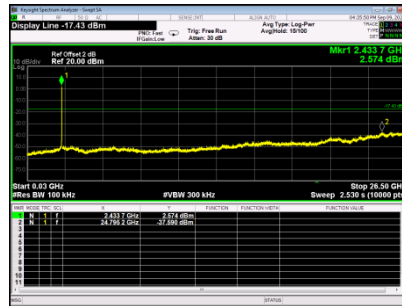

CH11

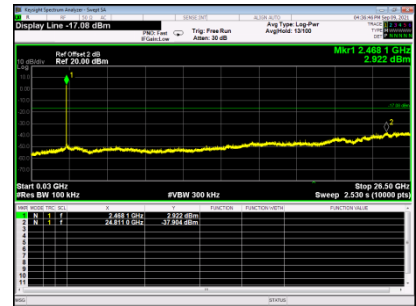

TX N (HT40) Mode _Ant 1

Bandedge-CH03

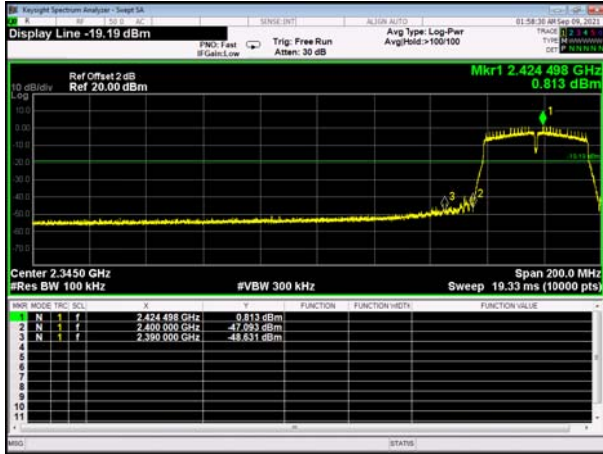

Bandedge-CH09

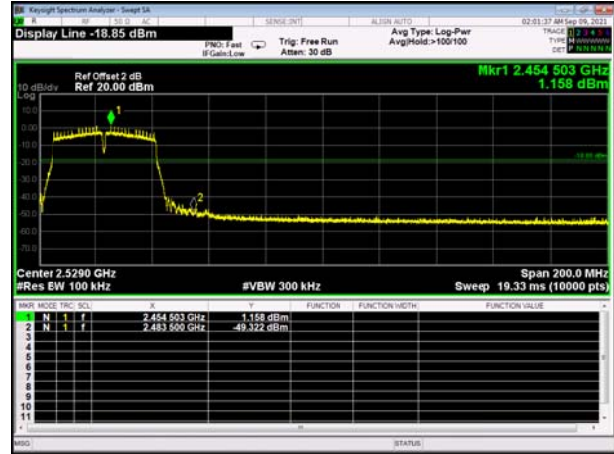

10th Harmonic of the fundamental frequency

CH03

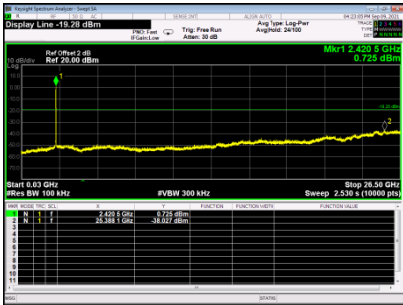

CH06

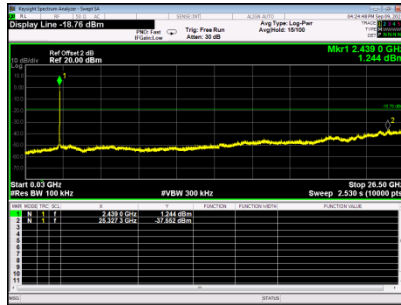

CH09

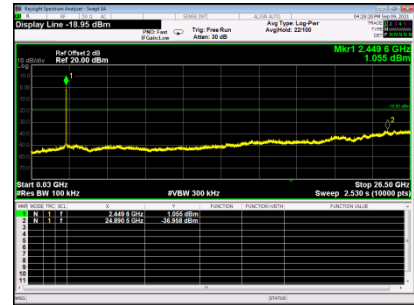

TX N (HT40) Mode _Ant 2

Bandedge-CH03

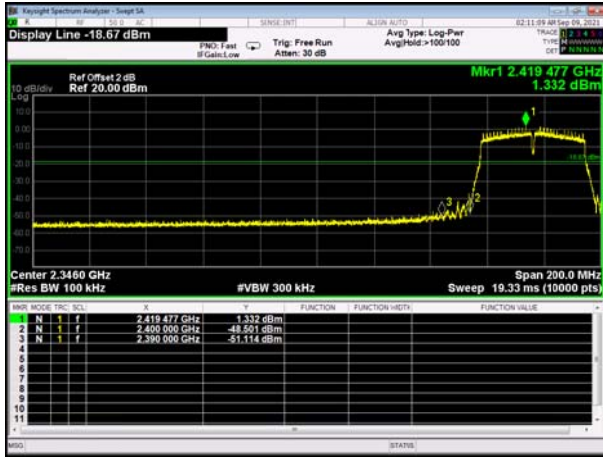

Bandedge-CH09

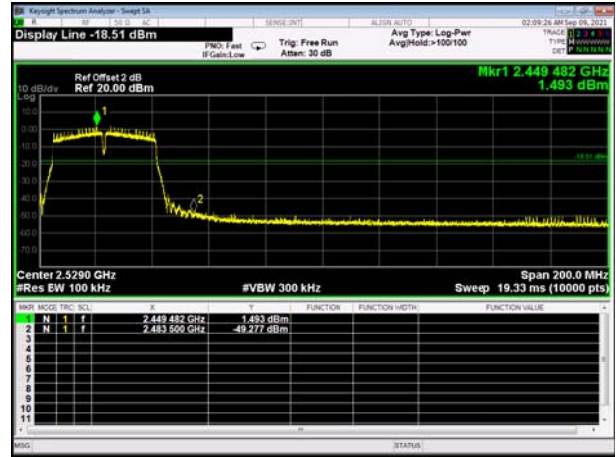

10th Harmonic of the fundamental frequency

CH03

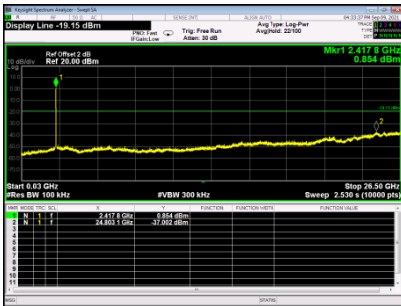

CH06

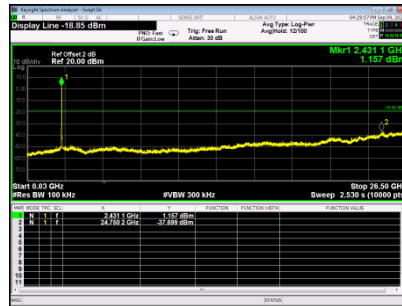

CH09

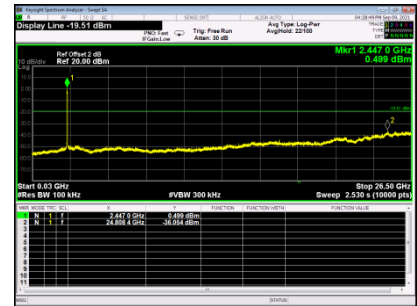

9 POWER SPECTRAL DENSITY TEST

9.1 LIMIT

FCC Part15, Subpart C (15.247)&RSS-247		
Section	Test Item	Limit
15.247(e) RSS-2475.2 (b)	Power Spectral Density	8 dBm (in any 3 kHz)

9.2 TEST PROCEDURE AND SETTING

- The EUT was directly connected to the spectrum analyzer and antenna output port as show in the block diagram below.
- Spectrum Setting: RBW=3 kHz, VBW=10 kHz, Sweep time = Auto.
- The Power Spectral Density was performed in accordance with method 11.10.2 of ANSI C63.10-2013.

9.3 MEASUREMENT INSTRUMENTS LIST

Item	Kind of Equipment	Manufacturer	Type No.	Serial No.	Calibrated until
1	Spectrum analyzer	KEYSIGHT	N9010A	MY55150427	2022/05/28
2	Attenuator	Mini-Circuits	BW-S10W2	101109	N/A
3	RF Cable	Mi-cable	C10-01-01-1	100309	N/A

9.4 TEST SETUP

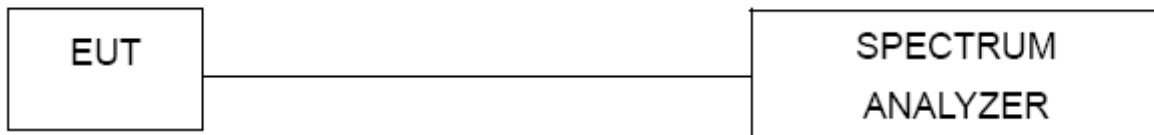

9.5 EUT OPERATION CONDITIONS

The EUT tested system was configured as the statements of 4.5 unless otherwise a special operating condition is specified in the follows during the testing.

9.6 TEST RESULTS

TX B Mode_Ant 1				
Channel	Frequency (MHz)	Power Spectral Density (dBm/3 kHz)	Limit: <dBm/3KHz	Result
01	2412	-8.736	8	PASS
06	2437	-9.392	8	PASS
11	2462	-8.503	8	PASS

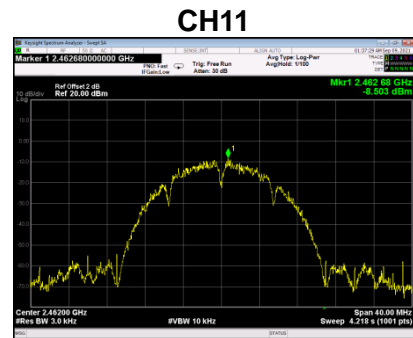
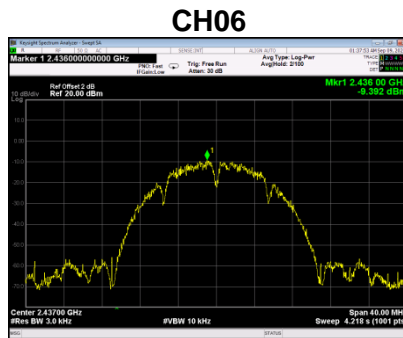
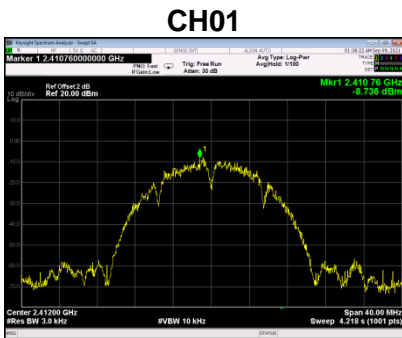

TX GMode_Ant 1				
Channel	Frequency (MHz)	Power Spectral Density (dBm/3 kHz)	Limit: <dBm/3KHz	Result
01	2412	-9.286	8	PASS
06	2437	-10.598	8	PASS
11	2462	-9.192	8	PASS

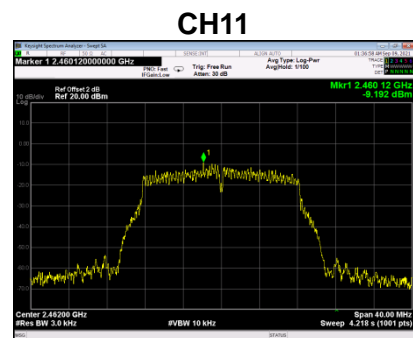
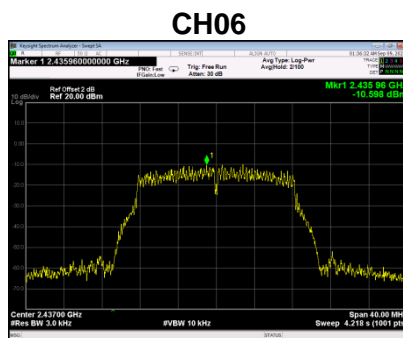
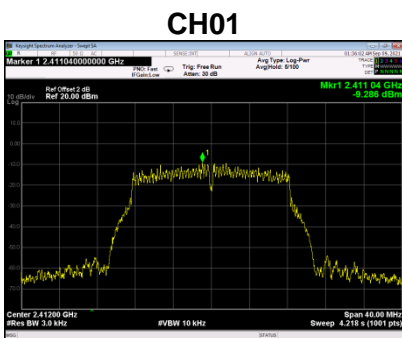

TX N (HT20) Mode_Ant 1

Channel	Frequency (MHz)	Power Spectral Density (dBm/3 kHz)	Limit: <dBm/3KHz	Result
01	2412	-10.807	8	PASS
06	2437	-11.011	8	PASS
11	2462	-10.885	8	PASS

CH01

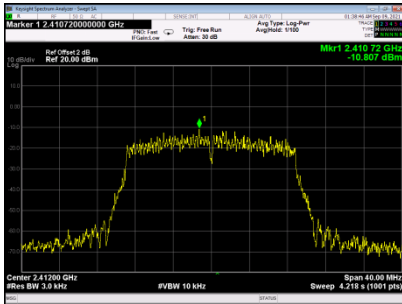

CH06

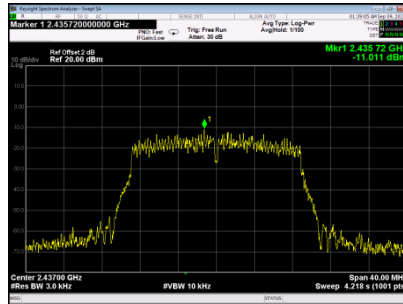

CH11

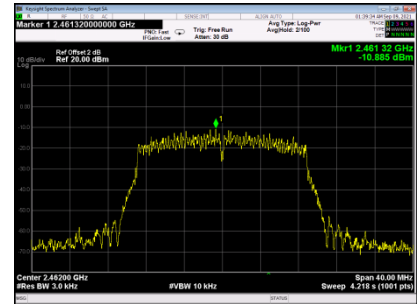

TX N (HT20) Mode_Ant 2

Channel	Frequency (MHz)	Power Spectral Density (dBm/3 kHz)	Limit: <dBm/3KHz	Result
01	2412	-10.411	8	PASS
06	2437	-10.931	8	PASS
11	2462	-10.197	8	PASS

CH01

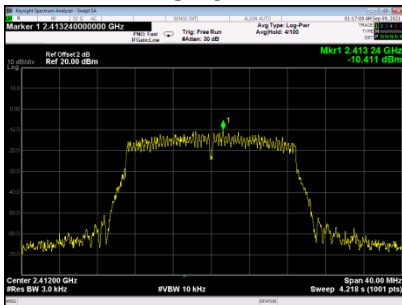

CH06

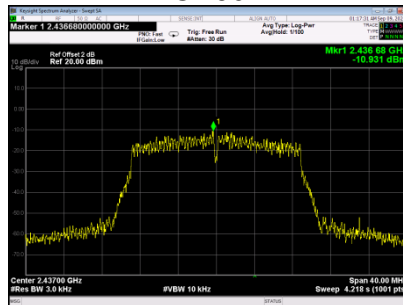

CH11

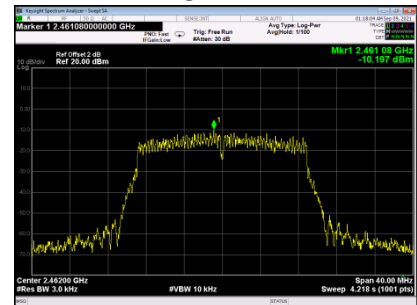

TX N (HT20) Mode_Total

Channel	Frequency (MHz)	Power Spectral Density (dBm/3 kHz)	Limit: <dBm/3KHz	Result
01	2412	-7.594	8	PASS
06	2437	-7.961	8	PASS
11	2462	-7.517	8	PASS

TX N (HT40) Mode_Ant 1

Channel	Frequency (MHz)	Power Spectral Density (dBm/3 kHz)	Limit: <dBm/3KHz	Result
03	2412	-13.719	8	PASS
06	2437	-13.865	8	PASS
09	2452	-14.723	8	PASS

CH03

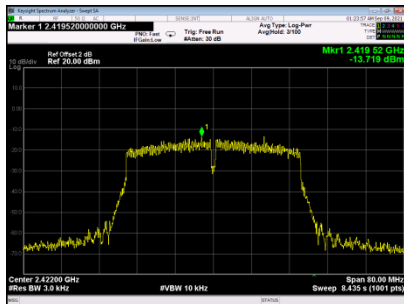

CH06

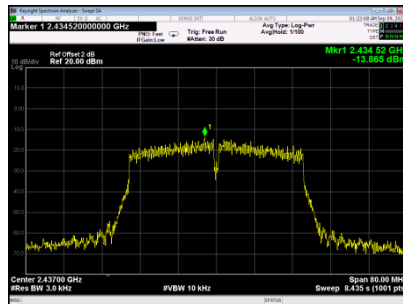

CH09

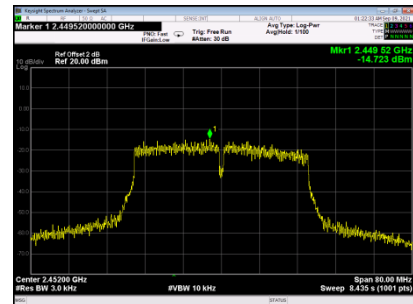

TX N (HT40) Mode_Ant 2

Channel	Frequency (MHz)	Power Spectral Density (dBm/3 kHz)	Limit: <dBm/3KHz	Result
03	2412	-13.883	8	PASS
06	2437	-12.551	8	PASS
09	2452	-12.859	8	PASS

CH03

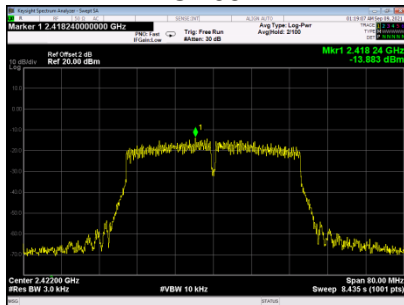

CH06

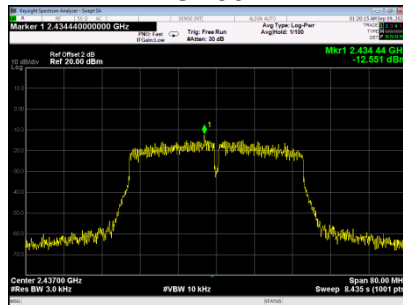

CH09

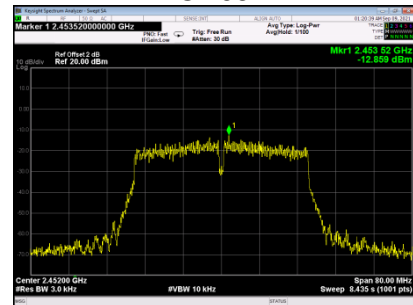

TX N (HT40) Mode_Total

Channel	Frequency (MHz)	Power Spectral Density (dBm/3 kHz)	Limit: <dBm/3KHz	Result
03	2412	-10.790	8	PASS
06	2437	-10.148	8	PASS
09	2452	-10.681	8	PASS

10 FREQUENCY STABILITY MEASUREMENT

10.1 LIMIT

RSS-Gen			
Section	Test Item	Limit	Frequency Range (MHz)
RSS-Gen 6.11	Frequency Stability	Specified in the user's manual	2412-2462

10.2 TEST PROCEDURE AND SETTING

- The EUT was directly connected to the spectrum analyzer and antenna output port as show in the block diagram below.
- Spectrum Setting:

Spectrum Parameter	Setting
Attenuation	Auto
Span Frequency	Entire absence of modulationemissionsbandwidth
RBW	10 kHz
VBW	10kHz
Sweep Time	Auto

10.3 MEASUREMENT INSTRUMENTS LIST

Item	Kind of Equipment	Manufacturer	Type No.	Serial No.	Calibrated until
1	Spectrum analyzer	KEYSIGHT	N9010A	MY55150427	2022/05/28
2	Attenuator	Mini-Circuits	BW-S10W2	101109	N/A
3	RF Cable	Mi-cable	C10-01-01-1	100309	N/A
4	Temperature conditioning	Guan Jian.HTH1000	-20-130°C	GJ1000-10D001	N/A
5	DC Power Supply	G.KE	IPR-10010D	010931954	N/A

10.4 TEST SETUP

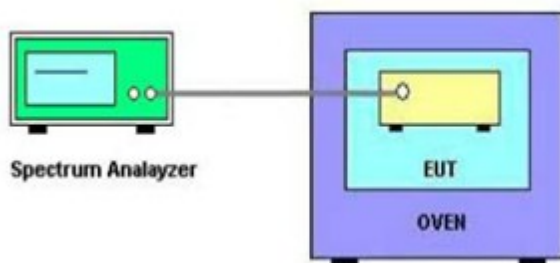

10.5 EUT OPERATION CONDITIONS

The EUT was programmed to be in continuously transmitting mode.

10.6 TEST RESULTS

Temperature vs. Frequency Stability		
Voltage	Temperature	Measurement Frequency (MHz)
5V	(°C)	2412
	-20	2411.983388
	25	2411.983108
	50	2411.981548
2.2V	25	2411.983115
Max. Deviation (MHz)		-0.018452
Max. Deviation (ppm)		-7.65

Note: 2.2V is the end point voltage, and products below 2.2V will cease working.

END OF TEST REPORT