

TEST REPORT

Report No.: 18091162HKG-001

Application For Original Grant of 47 CFR Part 15 Certification

This report contains the data of Bluetooth 2.1 portion only

WiseCube

FCC ID: 2AB7X-WISECUBE

Prepared and Checked by:

Approved by:

Signed On File
Kung Wing Cheong, Steven
Senior Lead Engineer

Tang Kwan Mo, Jess
Lead Engineer
Date: November 06, 2018

Intertek's standard Terms and Conditions can be obtained at our website <http://www.intertek.com/terms/>.

The test report only allows to be revised within the retention period unless further standard or the requirement was noticed.

This report is for the exclusive use of Intertek's Client and is provided pursuant to the agreement between Intertek and its Client. Intertek's responsibility and liability are limited to the terms and conditions of the agreement. Intertek assumes no liability to any party, other than to the Client in accordance with the agreement, for any loss, expense or damage occasioned by the use of this report. Only the Client is authorized to permit copying or distribution of this report and then only in its entirety. Any use of the Intertek name or one of its marks for the sale or advertisement of the tested material, product or service must first be approved in writing by Intertek. The observations and test results in this report are relevant only to the sample tested. This report by itself does not imply that the material, product, or service is or has ever been under an Intertek certification program.

© 2017 Intertek

TEST REPORT

GENERAL INFORMATION

Grantee:	BBPOS International Limited
Grantee Address:	Suite 1903-04, Tower 2, Nina Tower, 8 Yeung Uk Road, Tsuen Wan, N.T., Hong Kong.
FCC Specification Standard:	FCC Part 15, October 1, 2016 Edition
FCC ID:	2AB7X-WISECUBE
FCC Model(s):	WiseCube
Type of EUT:	Transceiver
Description of EUT:	WiseCube
Serial Number:	N/A
Sample Receipt Date:	September 27, 2018
Date of Test:	September 27, 2018 to November 02, 2018
Report Date:	November 06, 2018
Environmental Conditions:	Temperature: +10 to 40°C Humidity: 10 to 90%

TEST REPORT

TABLE OF CONTENTS

1.0 TEST RESULTS SUMMARY & STATEMENT OF COMPLIANCE 4

 1.1 Summary of Test Results4

 1.2 Statement of Compliance4

2.0 GENERAL DESCRIPTION 5

 2.1 Product Description.....5

 2.2 Test Methodology5

 2.3 Test Facility5

3.0 SYSTEM TEST CONFIGURATION..... 6

 3.1 Justification6

 3.2 EUT Exercising Software7

 3.3 Radiated Emission Test Setup8

 3.4 Conducted Emission Test Setup.....9

 3.5 Details of EUT and Description of Accessories.....10

 3.6 Measurement Uncertainty10

4.0 TEST RESULTS..... 11

 4.1 Field Strength Calculation11

 4.2 Radiated Emissions.....12

 4.2.1 Radiated Emission Configuration Photograph12

 4.2.2 Radiated Emission Data12

 4.3 Radiated Emission on the Bandedge.....17

 4.4 AC Power Line Conducted Emission20

 4.4.1 AC Power Line Conducted Emission Configuration Photograph20

 4.4.2 AC Power Line Conducted Emission Data.....20

5.0 EQUIPMENT LIST 23

TEST REPORT

1.0 TEST RESULTS SUMMARY & STATEMENT OF COMPLIANCE

1.1 Summary of Test Results

Test Items	FCC Part 15 Section	Results	Details See Section
Antenna Requirement	15.203	Pass	2.1
Security Code Information	15.214(d)	Pass	2.1
Radiated Emission	15.249(a), 209, & 109	Pass	4.2
Radiated Emission on the Bandedge	15.249(d)	Pass	4.3
Radiated Emission in Restricted Bands	15.205	Pass	4.2
AC Power Line Conducted Emission	15.207 & 15.107	Pass	4.4

Note: Pursuant to FCC Part 15 Section 15.215(c), the 20dB bandwidth of the emission was contained within the frequency band designated (mentioned as above) which the EUT operated. The effects, if any, from frequency sweeping, frequency hopping, other modulation techniques and frequency stability over expected variations in temperature and supply voltage were considered.

1.2 Statement of Compliance

The equipment under test is found to be complying with the following standards:

FCC Part 15, October 1, 2016 Edition

TEST REPORT

2.0 GENERAL DESCRIPTION

2.1 Product Description

The Equipment Under Test (EUT) is an RFID card reader that can support Bluetooth function. Bluetooth 2.1 is operating at the frequency range of 2402-2480MHz with 1 MHz channel spacing. The EUT is powered by 3.7V internal battery or 5.0V through type-C connector.

The Bluetooth antenna used in base unit is integral, and the test sample is a prototype.

The circuit description is saved with filename: descri.pdf.

2.2 Test Methodology

Both AC power line-conducted and radiated emission measurements were performed according to the procedures in ANSI C63.10 (2013). Preliminary radiated scans and all radiated measurements were performed in Radiated Emission Test Sites. All Radiated tests were performed at an antenna to EUT distance of 3 meters, unless stated otherwise in the "**Justification Section**" of this Application.

2.3 Test Facility

The radiated emission test sites and conducted measurement facility used to collect the radiated data and conducted data are at Workshop No. 3, G/F., World-Wide Industrial Centre, 43-47 Shan Mei Street, Fo Tan, Sha Tin, N.T., Hong Kong. This test facility and site measurement data have been fully placed on file with the FCC.

TEST REPORT

3.0 SYSTEM TEST CONFIGURATION

3.1 Justification

For radiated emissions testing, the equipment under test (EUT) was setup to transmit continuously mode to simplify the measurement methodology. Care was taken to ensure proper power supply voltages during testing. During testing, all cables (if any) were manipulated to produce worst case emissions.

The EUT is powered by fully charge 3.7V internal battery or 5.0V through type-C connector.

For the measurements, the EUT was attached to a plastic stand if necessary and placed on the wooden turntable which is four feet in diameter and approximately 0.8m in height above the ground plane for emission measurement at or below 1GHz and 1.5m in height above the ground plane for emission measurement above 1GHz. If the EUT attached to peripherals, they were connected and operational to simulate typical use.

The signal was maximized through rotation and placement in the three orthogonal axes. The antenna height and polarization were varied during the search for maximum signal level. The antenna height was varied from 1 to 4 meters. Radiated emissions were taken at three meters unless the signal level was too low for measurement at that distance. If necessary, a pre-amplifier was used and/or the test was conducted at a closer distance.

For any intentional radiator powered by AC power line, measurements of the radiated signal level of the fundamental frequency component of the emission was performed with the supply voltage varied between 85% and 115% of the nominal rated supply voltage.

For transmitter radiated measurement, the spectrum analyzer resolution bandwidth was 100 kHz for frequencies below 1000 MHz. The resolution bandwidth was 2 MHz for frequencies above 1000 MHz.

Radiated emission measurement for transmitter was performed from the lowest radio frequency signal generated in the device which is greater than 9 kHz to the tenth harmonic of the highest fundamental frequency or to 40 GHz, whichever is lower.

Emission that are directly caused by digital circuits in the transmit path and transmitter portion were measured, and the limit are according to FCC Part 15 Section 15.209. Digital circuitry used to control additional functions other than the operation of the transmitter are subject to FCC Part 15 Section 15.109 Limits.

TEST REPORT

3.1 Justification - Cont'd

Detector function for radiated emissions is in peak mode. Average readings, when required, are taken by measuring the duty cycle of the equipment under test and subtracting the corresponding amount in dB from the measured peak readings. A detailed description for the calculation of the average factor can be found in section 4.2.3.

Determination of pulse desensitization was made according to *Hewlett Packard Application Note 150-2, Spectrum Analysis... Pulsed RF*. The effective period (Teff) was 625 μ s. With the resolution bandwidth 1MHz and spectrum analyzer IF bandwidth 3dB, the pulse desensitization factor was 0dB.

For AC line conducted emission test, the EUT along with its peripherals were placed on a 1.0m(W)x1.5m(L) and 0.8m in height wooden table and the EUT was adjusted to maintain a 0.4 meter space from a vertical reference plane. The EUT was connected to power mains through a line impedance stabilization network (LISN), which provided 50ohm coupling impedance for measuring instrument. The LISN housing, measuring instrument case, reference ground plane, and vertical ground plane were bounded together. The excess power cable between the EUT and the LISN was bundled.

All connecting cables of EUT and peripherals were manipulated to find the maximum emission.

All relevant operation modes have been tested, and the worst case data was included in this report.

3.2 EUT Exercising Software

The EUT exercise program used during radiated and conducted testing was designed to exercise the various system components in a manner similar to a typical use.

TEST REPORT

3.3 Radiated Emission Test Setup

The figure below shows the test setup, which is utilized to make these measurements.

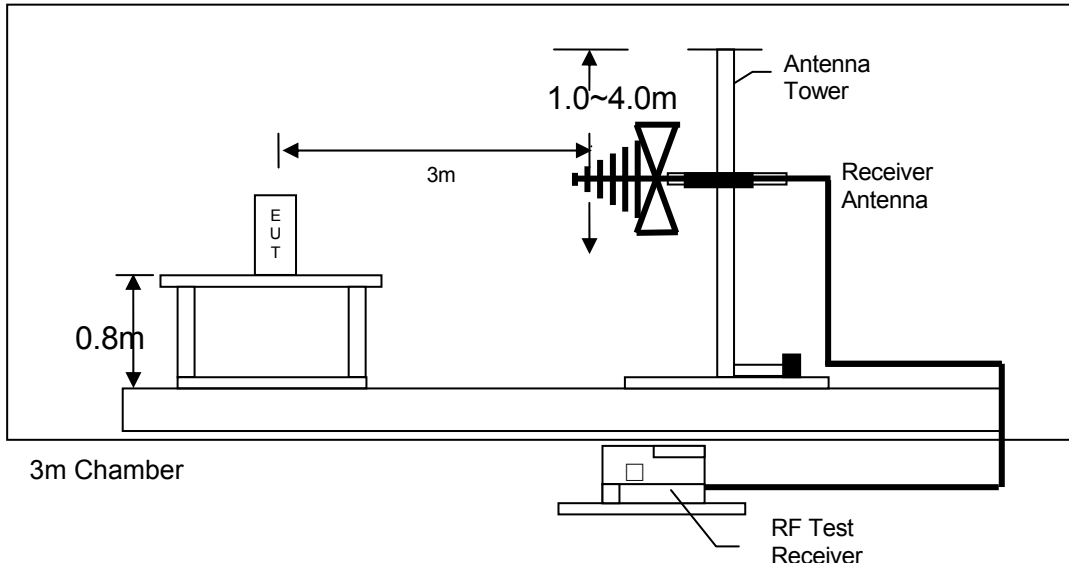

Figure 3.3.1 Test setup of radiated emissions up to 1GHz

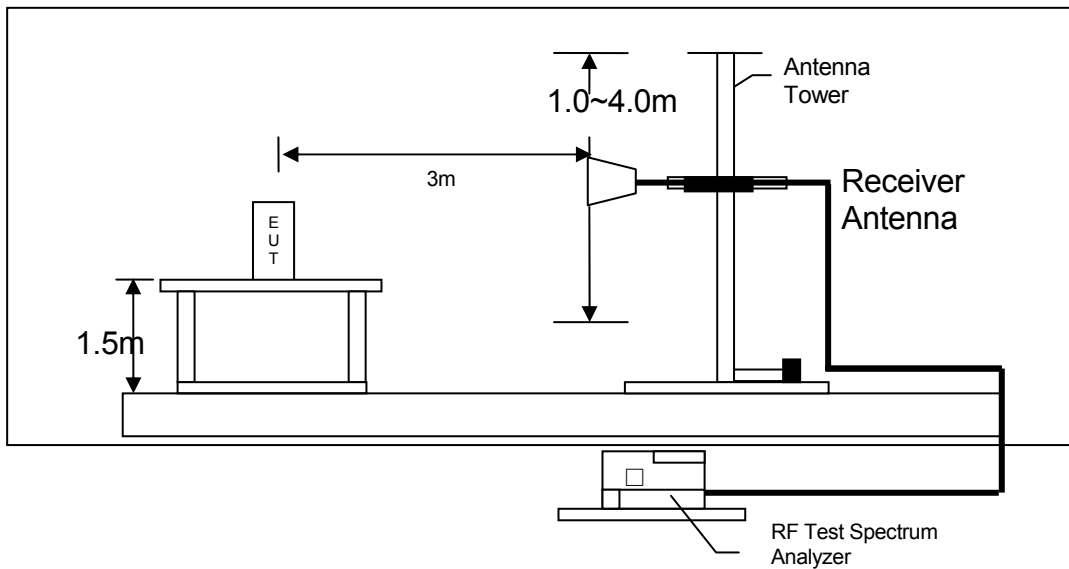

Figure 3.3.2 Test setup of radiated emissions above 1GHz

TEST REPORT

3.4 Conducted Emission Test Setup

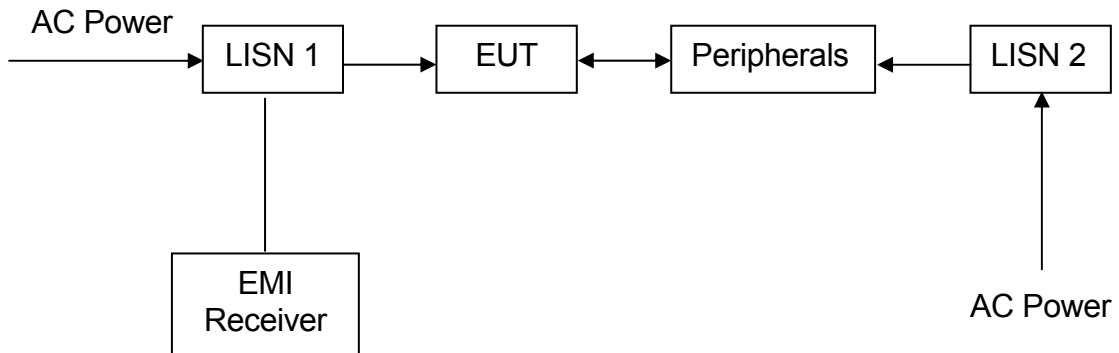

Figure 3.4.1

TEST REPORT

3.5 Details of EUT and Description of Accessories

Details of EUT:

The EUT is powered by 3.7V internal battery or 5.0V through type-C connector.

Description of Accessories:

- (1) 0.31m USB to type-C cable (Supplied by Client)
- (2) Adaptor (Brand: Apple, Model: A1399)(Supplied by Intertek)
- (3) Notebook (Model: HP Probook 430 G1) (Supplied by Intertek)
- (4) Adaptor of notebook (Model: PPP009L-E) (Supplied by Intertek)
- (5) Mobile phone (Brand: Samsung, Model: SM-G9287)(Supplied by Client)

3.6 Measurement Uncertainty

When determining of the test conclusion, the Measurement Uncertainty of test has been considered. The values of the Measurement uncertainty for radiated emission test, AC line conducted emission test and RF conducted test, frequency stability and timing jitter are $\pm 5.3\text{dB}$, $\pm 4.2\text{dB}$, $\pm 1\text{dB}$, $\pm 23\text{Hz}$, $0.1\mu\text{s}$ respectively.

Uncertainty and Compliance - Unless the standard specifically states that measured values are to be extended by the measurement uncertainty in determining compliance, all compliance determinations are based on the actual measured value.

TEST REPORT

4.0 TEST RESULTS

Data is included of the worst case configuration (the configuration which resulted in the highest emission levels). A sample calculation, configuration photographs and data tables of the emissions are included.

4.1 Field Strength Calculation

The field strength is calculated by adding the reading on the Spectrum Analyzer to the factors associated with preamplifiers (if any), antennas, cables, pulse desensitization and average factors (when specified limit is in average and measurements are made with peak detectors). A sample calculation is included below.

$$FS = RA + AF + CF - AG + PD + AV$$

where

- FS = Field Strength in dB μ V/m
- RA = Receiver Amplitude (including preamplifier) in dB μ V
- CF = Cable Attenuation Factor in dB
- AF = Antenna Factor in dB
- AG = Amplifier Gain in dB
- PD = Pulse Desensitization in dB
- AV = Average Factor in -dB

In the radiated emission table which follows, the reading shown on the data table may reflect the preamplifier gain. An example of the calculations, where the reading does not reflect the preamplifier gain, follows:

$$FS = RA + AF + CF - AG + PD + AV$$

Example

Assume a receiver reading of 62.0 dB μ V is obtained. The antenna factor of 7.4 dB and cable factor of 1.6 dB is added. The amplifier gain of 29 dB is subtracted. The pulse desensitization factor of the spectrum analyzer was 0 dB, and the resultant average factor was -10 dB. The net field strength for comparison to the appropriate emission limit is 32 dB μ V/m. This value in dB μ V/m was converted to its corresponding level in μ V/m.

$$\begin{aligned} RA &= 62.0 \text{ dB}\mu\text{V} \\ AF &= 7.4 \text{ dB} \\ CF &= 1.6 \text{ dB} \\ AG &= 29 \text{ dB} \\ PD &= 0 \text{ dB} \\ AV &= -10 \text{ dB} \\ FS &= 62 + 7.4 + 1.6 - 29 + 0 + (-10) = 32 \text{ dB}\mu\text{V/m} \end{aligned}$$

$$\text{Level in } \mu\text{V/m} = \text{Common Antilogarithm } [(32 \text{ dB}\mu\text{V/m})/20] = 39.8 \mu\text{V/m}$$

TEST REPORT

4.2 Radiated Emissions

4.2.1 Radiated Emission Configuration Photograph

Worst Case Radiated Emission
at

232.279 MHz

The worst case radiated emission configuration photographs are saved with filename: config photos.pdf

4.2.2 Radiated Emission Data

The data in tables 1-4 list the significant emission frequencies, the limit and the margin of compliance. Test setup is shown in section 3.3 Figure 3.3.1 and 3.3.2.

Judgement -

Passed by 11.2 dB margin

TEST REPORT

RADIATED EMISSION DATA

Lowest Channel

Table 1

Polarization	Frequency (MHz)	Reading (dBµV)	Pre-Amp Gain (dB)	Antenna Factor (dB)	Net at 3m - Average (dBµV/m)	Average Limit at 3m (dBµV/m)	Margin (dB)
H	2402.000	64.1	33	29.4	60.5	94.0	-33.5
H	4804.000	17.7	33	34.9	19.6	54.0	-34.4
V	7206.000	19.4	33	37.9	24.3	54.0	-29.7
H	9608.000	15.4	33	40.4	22.8	54.0	-31.2
H	12010.000	18.4	33	40.5	25.9	54.0	-28.1
H	14412.000	20.1	33	40.0	27.1	54.0	-26.9

Polarization	Frequency (MHz)	Reading (dBµV)	Pre-Amp Gain (dB)	Antenna Factor (dB)	Net at 3m - Peak (dBµV/m)	Peak Limit at 3m (dBµV/m)	Margin (dB)
H	2402.000	89.4	33	29.4	85.8	114.0	-28.2
H	4804.000	42.5	33	34.9	44.4	74.0	-29.6
V	7206.000	44.9	33	37.9	49.8	74.0	-24.2
H	9608.000	40.6	33	40.4	48.0	74.0	-26.0
H	12010.000	43.6	33	40.5	51.1	74.0	-22.9
H	14412.000	45.5	33	40.0	52.5	74.0	-21.5

- NOTES: 1. Peak detector and average detector are used for the emission measurement according to ANSI C63.10.
2. All measurements were made at 3 meters. Radiated emissions not detected at the 3-meter distance were measured at 0.3-meter and an inverse proportional extrapolation was performed to compare the signal level to the 3-meter limit. No other radiated emissions than those reported were detected at a test distance of 0.3-meter.
3. Negative value in the margin column shows emission below limit.
4. Horn antenna is used for the emission over 1000MHz.
5. Emission within the restricted band meets the requirement of FCC Part 15 Section 15.205.

TEST REPORT

Middle Channel

Table 2

Polarization	Frequency (MHz)	Reading (dBμV)	Pre-Amp Gain (dB)	Antenna Factor (dB)	Net at 3m - Average (dBμV/m)	Average Limit at 3m (dBμV/m)	Margin (dB)
H	2441.000	63.8	33	29.4	60.2	94.0	-33.8
H	4882.000	17.9	33	34.9	19.8	54.0	-34.2
V	7323.000	19.0	33	37.9	23.9	54.0	-30.1
H	9764.000	15.5	33	40.4	22.9	54.0	-31.1
H	12205.000	18.7	33	40.5	26.2	54.0	-27.8
H	14646.000	21.9	33	38.4	27.3	54.0	-26.7

Polarization	Frequency (MHz)	Reading (dBμV)	Pre-Amp Gain (dB)	Antenna Factor (dB)	Net at 3m - Peak (dBμV/m)	Peak Limit at 3m (dBμV/m)	Margin (dB)
H	2441.000	89.2	33	29.4	85.6	114.0	-28.4
H	4882.000	42.6	33	34.9	44.5	74.0	-29.5
V	7323.000	44.3	33	37.9	49.2	74.0	-24.8
H	9764.000	40.8	33	40.4	48.2	74.0	-25.8
H	12205.000	43.9	33	40.5	51.4	74.0	-22.6
H	14646.000	47.0	33	38.4	52.4	74.0	-21.6

NOTES: 1. Peak detector and average detector are used for the emission measurement according to ANSI C63.10.

2. All measurements were made at 3 meters. Radiated emissions not detected at the 3-meter distance were measured at 0.3-meter and an inverse proportional extrapolation was performed to compare the signal level to the 3-meter limit. No other radiated emissions than those reported were detected at a test distance of 0.3-meter.

3. Negative value in the margin column shows emission below limit.

4. Horn antenna is used for the emission over 1000MHz.

5. Emission within the restricted band meets the requirement of FCC Part 15 Section 15.205.

TEST REPORT

Highest Channel

Table 3

Polarization	Frequency (MHz)	Reading (dBμV)	Pre-Amp Gain (dB)	Antenna Factor (dB)	3m - Average (dBμV/m)	Average Limit at 3m (dBμV/m)	Margin (dB)
H	2480.000	64.5	33	29.4	60.9	94.0	-33.1
H	4960.000	18.2	33	34.9	20.1	54.0	-33.9
V	7440.000	19.1	33	37.9	24.0	54.0	-30.0
H	9920.000	15.4	33	40.4	22.8	54.0	-31.2
H	12400.000	18.0	33	40.5	25.5	54.0	-28.5
H	14880.000	22.6	33	38.4	28.0	54.0	-26.0

Polarization	Frequency (MHz)	Reading (dBμV)	Pre-Amp Gain (dB)	Antenna Factor (dB)	Net at 3m - Peak (dBμV/m)	Peak Limit at 3m (dBμV/m)	Margin (dB)
H	2480.000	89.7	33	29.4	86.1	114.0	-27.9
H	4960.000	42.9	33	34.9	44.8	74.0	-29.2
V	7440.000	44.6	33	37.9	49.5	74.0	-24.5
H	9920.000	40.7	33	40.4	48.1	74.0	-25.9
H	12400.000	43.8	33	40.5	51.3	74.0	-22.7
H	14880.000	47.3	33	38.4	52.7	74.0	-21.3

- NOTES: 1. Peak detector and average detector are used for the emission measurement according to ANSI C63.10.
2. All measurements were made at 3 meters. Radiated emissions not detected at the 3-meter distance were measured at 0.3-meter and an inverse proportional extrapolation was performed to compare the signal level to the 3-meter limit. No other radiated emissions than those reported were detected at a test distance of 0.3-meter.
3. Negative value in the margin column shows emission below limit.
4. Horn antenna is used for the emission over 1000MHz.
5. Emission within the restricted band meets the requirement of FCC Part 15 Section 15.205.

TEST REPORT

Mode: Bluetooth TX and charging by PC

Table 4

Polarization	Frequency (MHz)	Reading (dB μ V)	Pre-amp (dB)	Antenna Factor (dB)	Net at 3m (dB μ V/m)	Limit at 3m (dB μ V/m)	Margin (dB)
V	40.661	28.2	16	10.0	22.2	40.0	-17.8
V	54.250	26.0	16	11.0	21.0	40.0	-19.0
H	67.809	24.6	16	8.0	16.6	40.0	-23.4
V	81.367	30.0	16	7.0	21.0	40.0	-19.0
V	94.956	19.9	16	11.0	14.9	43.5	-28.6
H	108.484	23.6	16	14.0	21.6	43.5	-21.9
H	122.073	19.4	16	14.0	17.4	43.5	-26.1
H	135.602	27.6	16	14.0	25.6	43.5	-17.9
H	151.354	28.6	16	15.0	27.6	43.5	-15.9
H	165.948	30.2	16	17.0	31.2	43.5	-12.3
H	199.830	27.7	16	16.0	27.7	43.5	-15.8
H	232.279	32.8	16	18.0	34.8	46.0	-11.2
H	265.490	24.0	16	21.0	29.0	46.0	-17.0
H	345.013	24.9	16	24.0	32.9	46.0	-13.1

- NOTES:
1. Peak Detector Data is used for the emission measurement.
 2. All measurements were made at 3 meters. Harmonic emissions not detected at the 3-meter distances were measured at 0.3-meter and an inverse proportional extrapolation was performed to compare the signal level to the 3-meter limit. No other harmonic emissions than those reported were detected at a test distance of 0.3-meter.
 3. Negative sign in the column shows value below limit.
 4. Horn antenna is used for the emission over 1000MHz.
 5. Emission within the restricted band meets the requirement of FCC Part 15 Section 15.205.

TEST REPORT

4.3 Radiated Emission on the Bandedge

From the following plots, they show that the fundamental emissions are confined in the specified band (2400MHz to 2483.5MHz). In case of the fundamental emissions are within two standard bandwidths from the bandedge, the delta measurement technique is used for determining bandedge compliance. Standard bandwidth is the bandwidth specified by ANSI C63.10 (2013) for frequency being measured.

Emissions radiated outside of the specified frequency bands, except harmonics, are attenuated by 50dB below the level of the fundamental or to the general radiated emissions limits in FCC Part 15 Section 15.209, whichever is the lesser attenuation, which meet the requirement of FCC Part 15 Section 15.249(d).

The plots of radiated emission on the bandedge are saved as below.

TEST REPORT

LOWEST CHANNEL

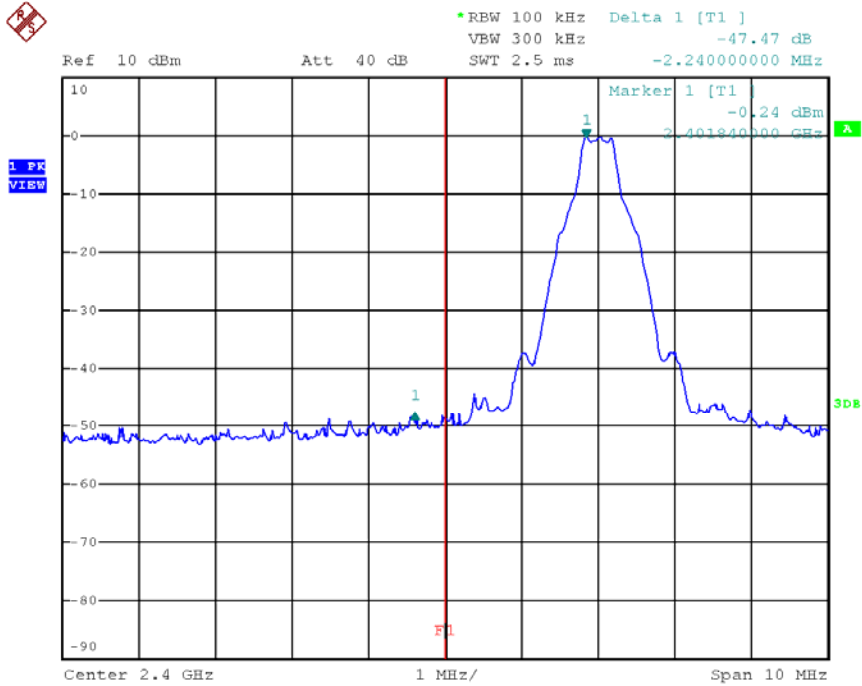

Date: 4.OCT.2018 03:27:34

HIGHEST CHANNEL

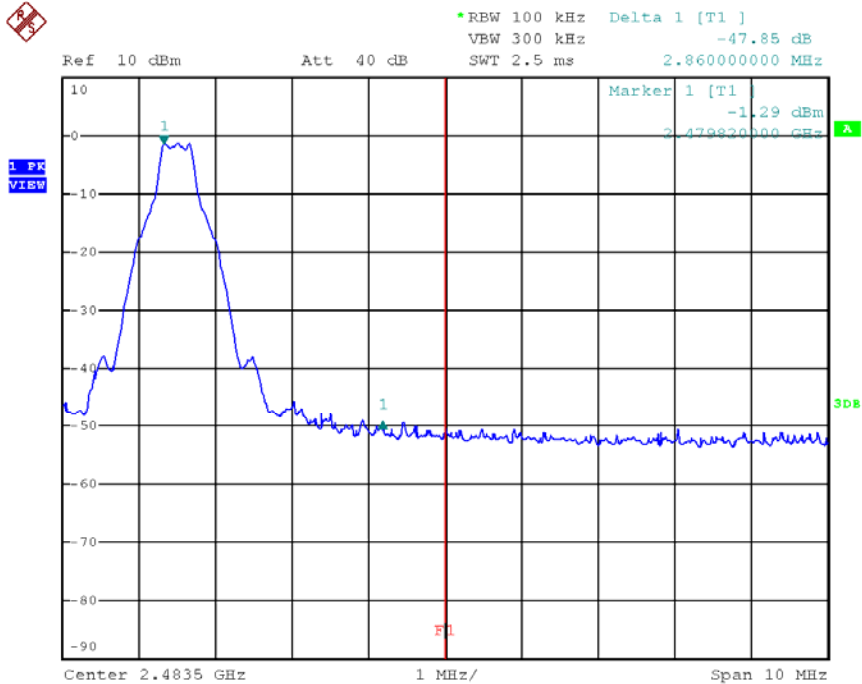

Date: 4.OCT.2018 03:30:46

TEST REPORT

Peak Measurement

Bandedge compliance is determined by applying marker-delta method, i.e. (Bandedge Plot).

Lower bandedge

Peak Resultant field strength = Fundamental emissions (peak value) – delta from the plot

=85.80 dB μ V/m – 47.47 dB

=38.33 dB μ V/m

Average Resultant field strength = Fundamental emissions (average value) – delta from the plot

=60.50 dB μ V/m – 47.47 dB

=13.03 dB μ V/m

Upper bandedge

Peak Resultant field strength = Fundamental emissions (peak value) – delta from the plot

=86.10 dB μ V/m – 47.85 dB

=38.25 dB μ V/m

Average Resultant field strength = Fundamental emissions (average value) – delta from the plot

=60.90 dB μ V/m – 47.85 dB

=13.05 dB μ V/m

The resultant field strength meets the general radiated emission limit in Section 15.209, which does not exceed 74 dB μ V/m (Peak Limit) and 54 dB μ V/m (Average Limit).

TEST REPORT

4.4 AC Power Line Conducted Emission

- [] Not applicable – EUT is only powered by battery for operation.
- [x] EUT connects to AC power line. Emission Data is listed in following pages.
- [] Base Unit connects to AC power line and has transmission. Handset connects to AC power line but has no transmission. Emission Data of Base Unit is listed in following pages.

Test setup is shown in section 3.4 Figure 3.4.1.

4.4.1 AC Power Line Conducted Emission Configuration Photograph

Worst Case Line-Conducted Configuration
at

0.8025 MHz

The worst case line conducted configuration photographs are saved with filename: config photos.pdf.

4.4.2 AC Power Line Conducted Emission Data

The plot(s) and data in the following pages list the significant emission frequencies, the limit and the margin of compliance.

Passed by 3.51 dB margin compared with CISPR average limit

TEST REPORT

CONDUCTED EMISSION DATA

Worst Case: Bluetooth TX and charging by adaptor

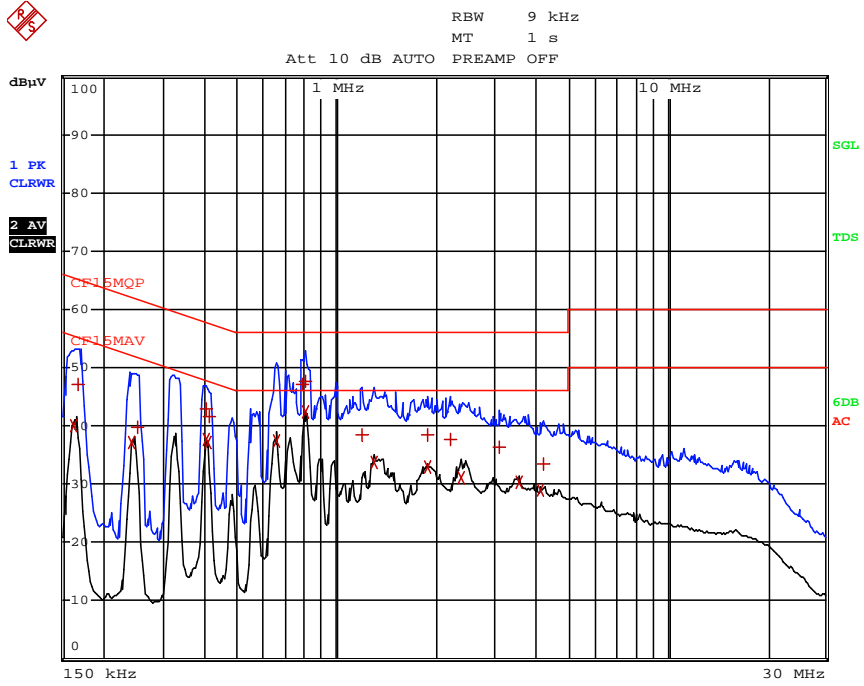

TEST REPORT

Worst Case: Bluetooth TX and charging by adaptor

EDIT PEAK LIST (Final Measurement Results)				
Trace1:	CF15MQP			
Trace2:	CF15MAV			
Trace3:	---			
TRACE	FREQUENCY	LEVEL dBµV		DELTA LIMIT dB
2 CISPR Average	163.5 kHz	40.11	N	-15.16
1 Quasi Peak	168 kHz	47.20	L1	-17.85
2 CISPR Average	244.5 kHz	37.11	N	-14.82
1 Quasi Peak	253.5 kHz	39.67	L1	-21.96
1 Quasi Peak	402 kHz	42.92	L1	-14.88
2 CISPR Average	402 kHz	37.61	L1	-10.19
2 CISPR Average	406.5 kHz	37.05	N	-10.66
1 Quasi Peak	411 kHz	41.49	L1	-16.13
2 CISPR Average	654 kHz	37.39	L1	-8.60
1 Quasi Peak	784.5 kHz	47.22	N	-8.77
2 CISPR Average	802.5 kHz	42.48	L1	-3.51
1 Quasi Peak	807 kHz	47.62	N	-8.37
1 Quasi Peak	1.1985 MHz	38.40	L1	-17.60
2 CISPR Average	1.2975 MHz	33.68	L1	-12.31
1 Quasi Peak	1.8735 MHz	38.51	L1	-17.48
2 CISPR Average	1.8915 MHz	33.06	L1	-12.93
1 Quasi Peak	2.2155 MHz	37.75	N	-18.24
2 CISPR Average	2.3865 MHz	31.15	L1	-14.84
1 Quasi Peak	3.1065 MHz	36.22	L1	-19.77
2 CISPR Average	3.543 MHz	30.29	L1	-15.70

EDIT PEAK LIST (Final Measurement Results)				
Trace1:	CF15MQP			
Trace2:	CF15MAV			
Trace3:	---			
TRACE	FREQUENCY	LEVEL dBµV		DELTA LIMIT dB
2 CISPR Average	4.1145 MHz	29.08	N	-16.91
1 Quasi Peak	4.2045 MHz	33.52	N	-22.47

TEST REPORT

5.0 EQUIPMENT LIST

1) Radiated Emissions Test

Equipment	EMI Test Receiver	Spectrum Analyzer	Biconical Antenna
Registration No.	EW-3156	EW-3281	EW-0571
Manufacturer	ROHDESCHWARZ	ROHDESCHWARZ	EMCO
Model No.	ESR26	FSV40	3104C
Calibration Date	November 10, 2017	January 02, 2018	February 27, 2018
Calibration Due Date	November 10, 2018	January 02, 2019	August 27, 2019

Equipment	Log Periodic Antenna	Double Ridged Guide Antenna	Log Periodic Antenna
Registration No.	EW-1042	EW-1133	EW-0447
Manufacturer	EMCO	EMCO	EMCO
Model No.	3148	3115	3146
Calibration Date	June 19, 2017	May 24, 2017	January 17, 2018
Calibration Due Date	December 19, 2018	November 24, 2018	July 17, 2019

Equipment	BiConiLog Antenna	Double Ridged Guide Antenna	Biconical Antenna
Registration No.	EW-3061	EW-0194	EW-2512
Manufacturer	EMCO	EMCO	EMCO
Model No.	3142E	3115	3104C
Calibration Date	November 02, 2017	March 14, 2018	August 06, 2018
Calibration Due Date	November 02, 2018	September 14, 2019	February 06, 2020

Equipment	Pyramidal Horn Antenna (18.0 - 26.5)GHz	RF Cable (up to 40GHz)	Notch Filter
Registration No.	EW-0905	EW-3155	EW-2213
Manufacturer	EMCO	N/A	MICROTRONICS
Model No.	3160-09	N/A	BRM50701-02
Calibration Date	August 18, 2017	January 29, 2018	May 24, 2018
Calibration Due Date	February 18, 2019	January 29, 2019	May 24, 2019

TEST REPORT

2) Conducted Emissions Test

Equipment	EMI Test Receiver	Artificial Mains Network	RF Cable
Registration No.	EW-3095	EW-2501	EW-3272
Manufacturer	R&S	ROHDESCHWARZ	GREATBILLION
Model No.	ESCI	ENV-216	N/A
Calibration Date	February 15, 2018	February 14, 2018	March 27, 2018
Calibration Due Date	February 15, 2019	February 14, 2019	March 27, 2019

3) Bandwidth Measurement

Equipment	Spectrum Analyzer
Registration No.	EW-3281
Manufacturer	ROHDESCHWARZ
Model No.	FSV40
Calibration Date	January 02, 2018
Calibration Due Date	January 02, 2019

END OF TEST REPORT