



**FCC 47 CFR PART 15 SUBPART C AND ANSI C63.4:2009
TEST REPORT**

For

Nuvola

Model : NP-1

Trade Name : NANOTECH

Issued for

NanoTech Entertainment

2450 Kruse Drive. San Jose, CA 95131

Issued by

**Compliance Certification Services Inc.
Hsinchu Lab.**

**NO. 989-1 Wen Shan Rd., Shang Shan Village,
Qionglin Shiang Hsinchu County 30741, Taiwan, R.O.C**

TEL: +886-3-5921698

FAX: +886-3-5921108

<http://www.ccsrf.com>

E-Mail : service@ccsrf.com

Issued Date: April 02, 2014



Note: This report shall not be reproduced except in full, without the written approval of Compliance Certification Services Inc. This document may be altered or revised by Compliance Certification Services Inc. personnel only, and shall be noted in the revision section of the document. The client should not use it to claim product endorsement by TAF or any government agencies. The test results of this report relate only to the tested sample identified in this report.



Revision History

Rev.	Issue Date	Revisions	Effect Page	Revised By
00	04/02/2014	Initial Issue	All Page 145	Michelle Chiu



TABLE OF CONTENTS

TITLE	PAGE NO.
1. TEST REPORT CERTIFICATION	4
2. EUT DESCRIPTION	5-6
3. DESCRIPTION OF TEST MODES	7-8
4. TEST METHODOLOGY	9
5. FACILITIES AND ACCREDITATION	9
5.1 FACILITIES	9
5.2 ACCREDITATIONS.....	9
5.3 MEASUREMENT UNCERTAINTY	10
6. SETUP OF EQUIPMENT UNDER TEST.....	11-12
7. FCC PART 15.247 REQUIREMENTS	13
7.1 6dB BANDWIDTH	13-33
7.2 MAXIMUM PEAK OUTPUT POWER	34-37
7.3 AVERAGE POWER	38-41
7.4 POWER SPECTRAL DENSITY	42-63
7.5 CONDUCTED SPURIOUS EMISSION	64-92
7.6 RADIATED EMISSION.....	93-135
7.7 CONDUCTED EMISSION	136-140
APPENDIX I MAXIMUM PERMISSIBLE EXPOSURE	141-142
APPENDIX II SETUP PHOTOS	143-145



1. TEST REPORT CERTIFICATION

Applicant : NanoTech Entertainment
Address : 2450 Kruse Drive. San Jose, CA 95131
Equipment Under Test : Nuvola
Model : NP-1
Trade Name : NANOTECH
Tested Date : November 05 ~ 18, 2013 ; March 26 ~ April 02,2014

APPLICABLE STANDARD	
Standard	Test Result
FCC Part 15 Subpart C AND ANSI C63.4:2009	PASS

WE HEREBY CERTIFY THAT: The above equipment has been tested by Compliance Certification Services Inc., and found compliance with the requirements set forth in the technical standards mentioned above. The results of testing in this report apply only to the product/system, which was tested. Other similar equipment will not necessarily produce the same results due to production tolerance and measurement uncertainties.

Approved by:

Sb. Lu
Sr. Engineer

Reviewed by:

Gundam Lin
Sr. Engineer



2. EUT DESCRIPTION

Product Name	Nuvola
Model Number	NP-1
Identify Number	T140326D06-B
Received Date	November 05, 2013
Frequency Range	IEEE 802.11a, 802.11an HT20 : 5745MHz ~ 5825Hz IEEE 802.11an HT40 : 5755MHz~5795MHz IEEE 802.11b/g, 802.11n HT20 : 2412MHz ~ 2462MHz Bluetooth 4.0 : 2402MHz ~ 2480MHz
Transmit Power	5GHz : IEEE 802.11a : 24.86 dBm (0.3061W) IEEE 802.11an HT20 : 27.66 dBm (0.5867W) IEEE 802.11an HT40 : 27.60 dBm (0.5751W) 2.4GHz : IEEE 802.11b : 16.84 dBm (0.0483W) IEEE 802.11g : 22.77 dBm (0.1891W) IEEE 802.11n HT20 : 24.68 dBm (0.2936W) Bluetooth 4.0: 7.70 dBm (0.0059W)
Channel Spacing	IEEE 802.11a, 802.11an/n HT20 : 20MHz IEEE 802.11an HT40 : 40MHz IEEE 802.11b/g, 802.11n HT20 : 5MHz Bluetooth 4.0: 2MHz
Channel Number	IEEE 802.11a, IEEE 802.11an HT20: 5 Channels IEEE 802.11an HT40 : 2 Channels IEEE 802.11b/g, IEEE 802.11n HT20: 11 Channels Bluetooth 4.0: 40 Channels
Transmit Data Rate	IEEE 802.11b : 11, 5.5, 2, 1 Mbps IEEE 802.11a/g : 54, 48, 36, 24, 18, 12, 9, 6 Mbps IEEE 802.11n/an HT20 : 144.4, 130, 117, 115.6, 104, 86.7, 78, 72.2, 65, 58.5, 57.8, 52, 43.3, 39, 28.9, 26, 21.7, 19.5, 14.4, 13, 7.2, 6.5Mbps IEEE 802.11an HT40 : 300, 270, 243, 240, 216, 180, 162, 150, 135, 121.5, 120, 108, 90, 81, 60, 54, 45, 40.5, 30, 27, 15, 13.5Mbps Bluetooth 4.0 : Additional GFSK
Type of Modulation	IEEE 802.11b : DSSS (CCK, DQPSK, DBPSK) IEEE 802.11a/g : OFDM (64QAM, 16QAM, QPSK, BPSK) IEEE 802.11an/n HT20/40 : OFDM (64QAM, 16QAM, QPSK, BPSK) Bluetooth 4.0 : Frequency Hopping Spread Spectrum



Antenna Type	PCB Antenna × 2 (2.4GHz & 5GHz), 2.4GHz : Ant 1 (Chain 1), Antenna Gain 2.77 dBi Ant 2 (Chain 2), Antenna Gain 2.72 dBi Bluetooth : Ant 1 (Chain 1), Antenna Gain 2.77 dBi 5GHz : Ant 1 (Chain 1), Antenna Gain 3.20 dBi Ant 2 (Chain 2), Antenna Gain 3.17 dBi
Power Rating	5.2Vdc
Test Voltage	120Vac, 60Hz
DC Power Cable Type	Non-shielded cable 1.5m (Non-detachable)
I/O Port	Micro SD Port × 1, HDMI Port × 1, RJ-45 Port × 1, USB 2.0 Port × 1, USB 3.0 Port × 1, Power Port × 1

Power Adapter :

No.	Manufacturer	Model No.	Power Input	Power Output
1	DVE	DSA-24CA-05 052300	100-240Vac, 50/60Hz, 0.8A	+5.2Vdc, 3A

Remark :

1. The sample selected for test was engineering sample that approximated to production product and was provided by manufacturer.
2. For more details, please refer to the User's manual of the EUT.
3. This submittal(s) (test report) is intended for FCC ID: 2AB5MNP-11001 filing to comply with Section 15.207, 15.209 and 15.247 of the FCC Part 15, Subpart C Rules.
4. This report is modified from T131106D02-RP1.
5. The EUT has two appearance, one for hanging on the wall, the other one for flat. The detail please refer to photos.



3. DESCRIPTION OF TEST MODES

The EUT is an 802.11n MIMO transceiver in Nuvola form factor.

For IEEE 802.11a/b/g mode (1TX / 1RX) : Chain 1(Ant 1) transmit/receive.

For IEEE 802.11an/n HT20/HT40 mode (2TX / 2RX) :

Chain 1(Ant 1) & Chain 2(Ant 2) transmit/receive.

For Bluetooth : Chain 1(Ant 1) transmit/receive.

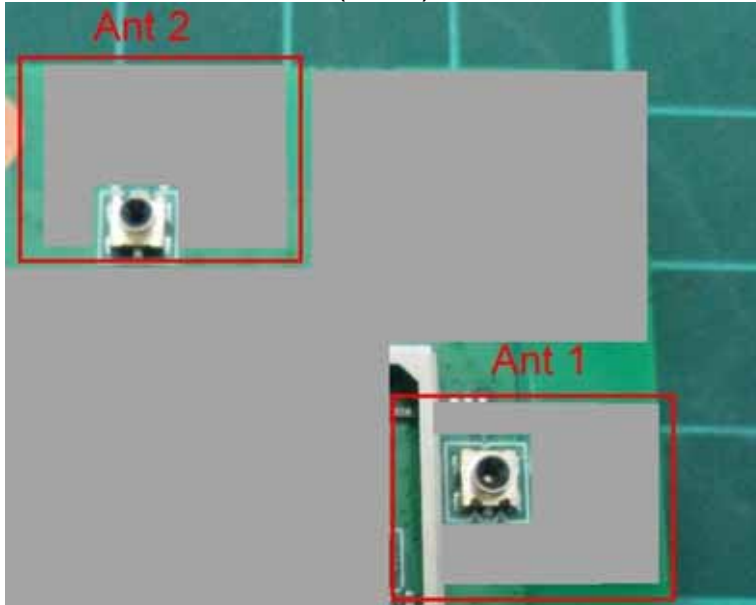

Conducted Emission / Radiated Emission Test (Below 1 GHz)

1. The following test modes were scanned during the preliminary test:

No.	Pre-Test Mode
1	TX Mode

2. After the preliminary scan, the following test mode was found to produce the highest emission level.

Final Test Mode		
Emission	Radiated Emission	TX Mode
	Conducted Emission	TX Mode

Remark : Then, the above highest emission mode of the configuration of the EUT and cable was chosen for all final test items.



Conducted / Radiated Emission Test (Above 1 GHz)

IEEE ,802.11a ,802.11an HT20 mode

The EUT had been tested under operating condition.

There are three channels have been tested as following :

Channel	Frequency (MHz)
Low	5745
Middle	5785
High	5825

IEEE 802.11a mode : 6Mbps data rate (worst case) were chosen for full testing.

IEEE 802.11an HT20 mode : 13Mbps data rate (worst case) were chosen for full testing.

IEEE 802.11an HT40 mode

The EUT had been tested under operating condition.

There are three channels have been tested as following :

Channel	Frequency (MHz)
Low	5755
High	5795

IEEE 802.11n HT40 mode : 27Mbps data rate (worst case) were chosen for full testing.

IEEE 802.11b, 802.11g, 802.11n HT20 mode

The EUT had been tested under operating condition.

There are three channels have been tested as following :

Channel	Frequency (MHz)
Low	2412
Middle	2437
High	2462

IEEE 802.11b mode : 1Mbps data rate (worst case) were chosen for full testing.

IEEE 802.11g mode : 6Mbps data rate (worst case) were chosen for full testing.

IEEE 802.11n HT20 mode : 13Mbps data rate (worst case) were chosen for full testing.

Bluetooth 4.0 Mode

The EUT had been tested under operating condition.

There are three channels have been tested as following :

Channel	Frequency (MHz)
Low	2402
Middle	2440
High	2480



4. TEST METHODOLOGY

The tests documented in this report were performed in accordance with ANSI C63.4: 2009 and FCC CFR 47, 15.207, 15.209 and 15.247.

5. FACILITIES AND ACCREDITATION

5.1 FACILITIES

All measurement facilities used to collect the measurement data are located at

NO. 989-1 Wen Shan Rd., Shang Shan Village,
Qionglin Shiang Hsinchu County 30741, Taiwan, R.O.C

The sites are constructed in conformance with the requirements of ANSI C63.4:2009 and CISPR 22. All receiving equipment conforms to CISPR 16-1-1, CISPR 16-1-2, CISPR 16-1-3, CISPR 16-1-4, CISPR 16-1-5.

5.2 ACCREDITATIONS

Our laboratories are accredited and approved by the following approval agencies according to ISO/IEC 17025.

Taiwan	TAF
---------------	-----

The measuring facility of laboratories has been authorized or registered by the following approval agencies.

Canada	INDUSTRY CANADA
Japan	VCCI
Taiwan	BSMI
USA	FCC MRA

Copies of granted accreditation certificates are available for downloading from our web site, <http://www.ccsrf.com>



5.3 MEASUREMENT UNCERTAINTY

The following table is for the measurement uncertainty, which is calculated as per the document CISPR 16-4-2.

PARAMETER	UNCERTAINTY
Semi Anechoic Chamber (966 Chamber_B) / Radiated Emission, 30 to 1000 MHz	+/- 3.97
Semi Anechoic Chamber (966 Chamber_B) / Radiated Emission, 1 to 18GHz	+/- 3.58
Semi Anechoic Chamber (966 Chamber_B) / Radiated Emission, 18 to 26 GHz	+/- 3.59
Semi Anechoic Chamber (966 Chamber_B) / Radiated Emission, 26 to 40 GHz	+/- 3.81
Conducted Emission (Mains Terminals), 9kHz to 30MHz	+/- 2.48

This uncertainty represents an expanded uncertainty expressed at approximately the 95% confidence level using a coverage factor of $k=2$.

Consistent with industry standard (e.g. CISPR 22, clause 11, Measurement Uncertainty) determining compliance with the limits shall be base on the results of the compliance measurement. Consequently the measure emissions being less than the maximum allowed emission result in this be a compliant test or passing test.

The acceptable measurement uncertainty value without requiring revision of the compliance statement is base on conducted and radiated emissions being less than U_{CISPR} which is 3.6dB and 5.2dB respectively. CCS values (called U_{Lab} in CISPR 16-4-2) is less than U_{CISPR} as shown in the table above. Therefore, MU need not be considered for compliance.



6. SETUP OF EQUIPMENT UNDER TEST

SUPPORT EQUIPMENT

No.	Product	Manufacturer	Model No.	Serial No.	FCC ID
1	Notebook PC	HP	ProBook 4421s	CNF03242PJ	DoC

SETUP DIAGRAM FOR TESTS

EUT & peripherals setup diagram is shown in appendix setup photos.

EUT OPERATING CONDITION

WiFi :

1. Setup all Nuvolas like the setup diagram.
2. Run MS-DOS → C: foxconn\adb
3. Keyin:adb shell
4. Keyin:ifconfig wlan0 up
5. Run MS-DOS → C: foxconn> Enter the command
6. TX Mode:

```

adb shell wl pkteng_stop tx
adb shell wl ver
adb shell wl mpc 0
adb shell wl country ALL
adb shell wl up
adb shell wl phy_oclscdenable 0
adb shell wl interference 0
adb shell wl scansuppress 1
adb shell wl isup
adb shell wl down
adb shell wl band xx                # b=2G, a=5G
adb shell wl mimo_preamble 0
adb shell wl mimo_bw_cap xx        # 2=2G&5G for HT40
adb shell wl mimo_txbw xx
adb shell wl chanspec -c xx -b xx -w 20    # c xx=channel ,b xx= band
adb shell wl up
adb shell wl phy_watchdog 0
adb shell wl sgi_tx 0
adb shell wl nrate -m xx -s 3          # r xx=b/g rate,m xx=n rate
adb shell wl down
adb shell wl up

```



```
adb shell wl txchain xx # 1=ant1,2=ant2,3=2TX
adb shell wl rxchain xx # 1=ant1,2=ant2,3=2RX
adb shell wl txpwr1 -o -q xx # power set 4=1dBm
adb shell wl phy_forcecal 1
adb shell wl pkteng_start 10:20:30:40:50:60 tx 100 1500 0
```

- ⇒ **Tx Data Rate:** 1Mbps Bandwidth 20 (IEEE 802.11b mode)
6Mbps Bandwidth 20 (IEEE 802.11a/g mode)
13Mbps Bandwidth 20 (IEEE 802.11an/n HT20 mode)
27Mbps Bandwidth 40 (IEEE 802.11an HT40 mode)

⇒ **Power control**

```
IEEE 802.11b Channel Low (2412MHz) TX Power 56
IEEE 802.11b Channel Mid (2437MHz) TX Power 56
IEEE 802.11b Channel High (2462MHz) TX Power 54
IEEE 802.11g Channel Low (2412MHz) TX Power 36
IEEE 802.11g Channel Mid (2437MHz) TX Power 60
IEEE 802.11g Channel High (2462MHz) TX Power 36
IEEE 802.11n HT20 Channel Low (2412MHz) TX Power 36/36
IEEE 802.11n HT20 Channel Mid (2437MHz) TX Power 56/56
IEEE 802.11n HT20 Channel High (2462MHz) TX Power 36/36
IEEE 802.11a Channel Low (5745MHz) TX Power 72
IEEE 802.11a Channel Mid (5785MHz) TX Power 72
IEEE 802.11a Channel High (5825MHz) TX Power 72
IEEE 802.11an HT20 Cannel Low (5745MHz) TX Power 72/72
IEEE 802.11an HT20 Channel Mid (5785MHz) TX Power 72/72
IEEE 802.11an HT20 Channel High (5825MHz) TX Power 72/72
IEEE 802.11an HT40 Channel Low (5755MHz) TX Power 64/64
IEEE 802.11an HT40 Channel High (5795MHz) TX Power 72/72
```

- 8. All of the functions are under run.
- 9. Start test.

Bluetooth 4.0 :

- 1. EUT & peripherals setup diagram is shown in appendix setup photos.
- 2. Run MS-DOS→C: foxconn\adb
- 3. Keyin: brcmbt
- 4. Run MS-DOS→C: foxconn\adb> Enter the command
- 5. TX Mode
 - a: hcicmd 03 0C 00
 - b: hcicmd 1E 20 03 xx 25 00 # xx=channel
 - c: hcicmd 1E 20 03 00 xx 00 # xx xx=packet

- 6. All of the functions are under run.
- 7. Start test.



7. FCC PART 15.247 REQUIREMENTS

7.1 6dB BANDWIDTH

LIMITS

§ 15.247(a) (2) For direct sequence systems, the minimum 6dB bandwidth shall be at least 500kHz.

TEST EQUIPMENT

Name of Equipment	Manufacturer	Model	Serial Number	Calibration Due
Spectrum Analyzer	Agilent	E4446A	MY43360132	06/10/2014

Remark: Each piece of equipment is scheduled for calibration once a year.

TEST SETUP

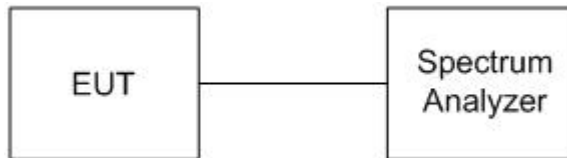

TEST PROCEDURE

1. The transmitter output was connected to a spectrum analyzer.
2. Set RBW = 100 kHz.
3. Set the video bandwidth (VBW) $\geq 3 \times$ RBW.
4. Detector = Peak.
5. Trace mode = max hold.
6. Sweep = auto couple.
7. Allow the trace to stabilize.
8. Measure the maximum width of the emission that is constrained by the frequencies associated with the two outermost amplitude points (upper and lower frequencies) that are attenuated by 6 dB relative to the maximum level measured in the fundamental emission.



TEST RESULTS

IEEE 802.11a Mode

Channel	Channel Frequency (MHz)	6dB Bandwidth (MHz)		Minimum Limit (kHz)	Pass / Fail
		Chain 1			
Low	5745	15.175		500	PASS
Middle	5785	15.350		500	PASS
High	5825	15.325		500	PASS

IEEE 802.11an HT20 Mode (Two TX)

Channel	Channel Frequency (MHz)	6dB Bandwidth (MHz)		Minimum Limit (kHz)	Pass / Fail
		Chain 1	Chain 2		
Low	5745	15.120	15.045	500	PASS
Middle	5785	15.140	15.060	500	PASS
High	5825	15.065	14.980	500	PASS

IEEE 802.11an HT40 Mode (Two TX)

Channel	Channel Frequency (MHz)	6dB Bandwidth (MHz)		Minimum Limit (kHz)	Pass / Fail
		Chain 1	Chain 2		
Low	5755	36.150	36.280	500	PASS
High	5795	36.270	36.035	500	PASS

**IEEE 802.11b Mode**

Channel	Channel Frequency (MHz)	6dB Bandwidth (MHz)		Minimum Limit (kHz)	Pass / Fail
		Chain 1			
Low	2412	8.080		500	PASS
Middle	2437	8.030		500	PASS
High	2462	8.085		500	PASS

IEEE 802.11g Mode

Channel	Channel Frequency (MHz)	6dB Bandwidth (MHz)		Minimum Limit (kHz)	Pass / Fail
		Chain 1			
Low	2412	15.320		500	PASS
Middle	2437	15.080		500	PASS
High	2462	15.375		500	PASS

IEEE 802.11n HT20 Mode (Two TX)

Channel	Channel Frequency (MHz)	6dB Bandwidth (MHz)		Minimum Limit (kHz)	Pass / Fail
		Chain 1	Chain 2		
Low	2412	15.025	15.080	500	PASS
Middle	2437	15.110	15.710	500	PASS
High	2462	15.110	15.675	500	PASS

Bluetooth 4.0 Mode

Channel	Channel Frequency (MHz)	6dB Bandwidth (kHz)		Minimum Limit (kHz)	Pass / Fail
		Chain 1			
Low	2402	679		500	PASS
Middle	2440	684		500	PASS
High	2480	669		500	PASS



6dB BANDWIDTH

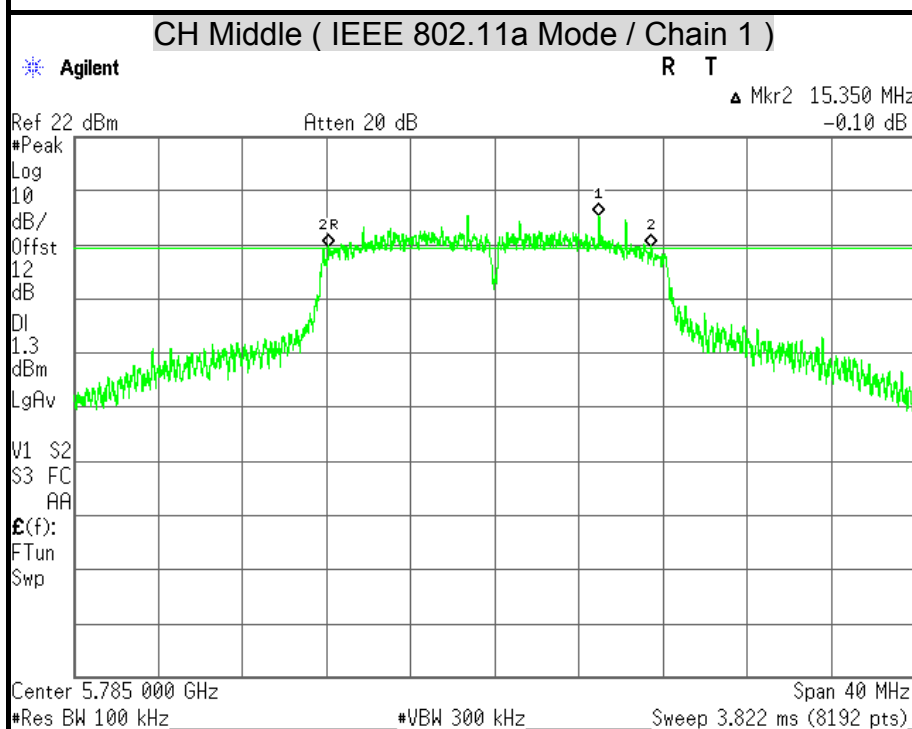
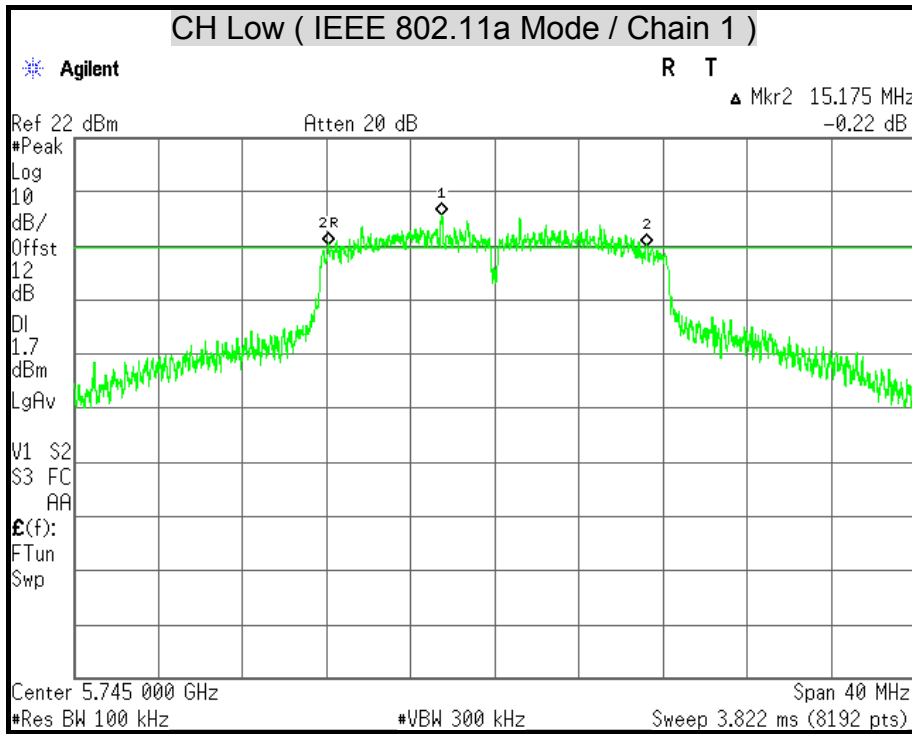

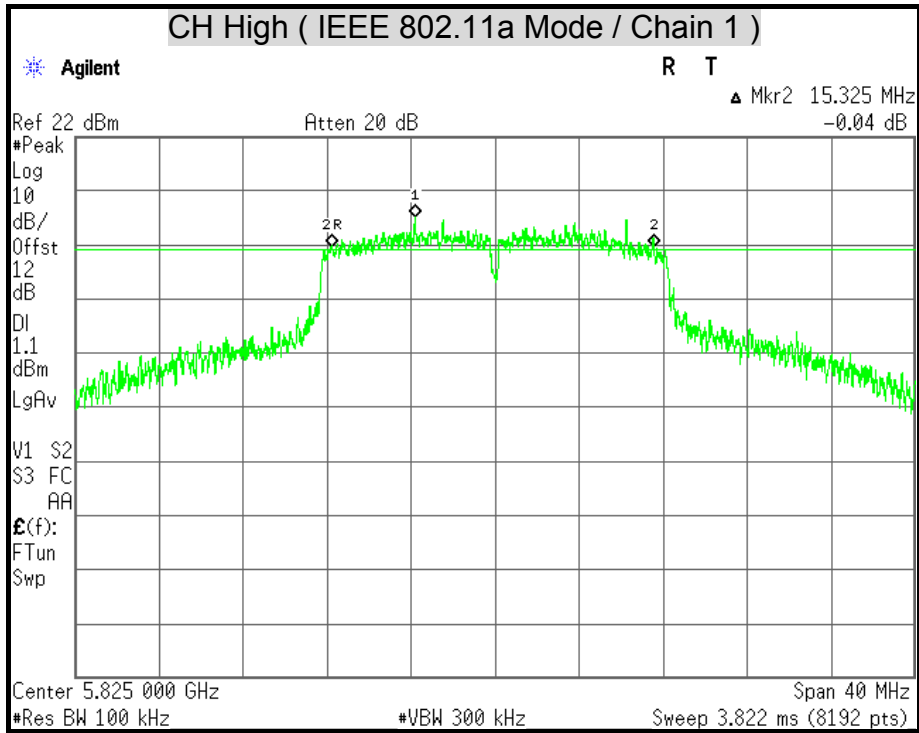

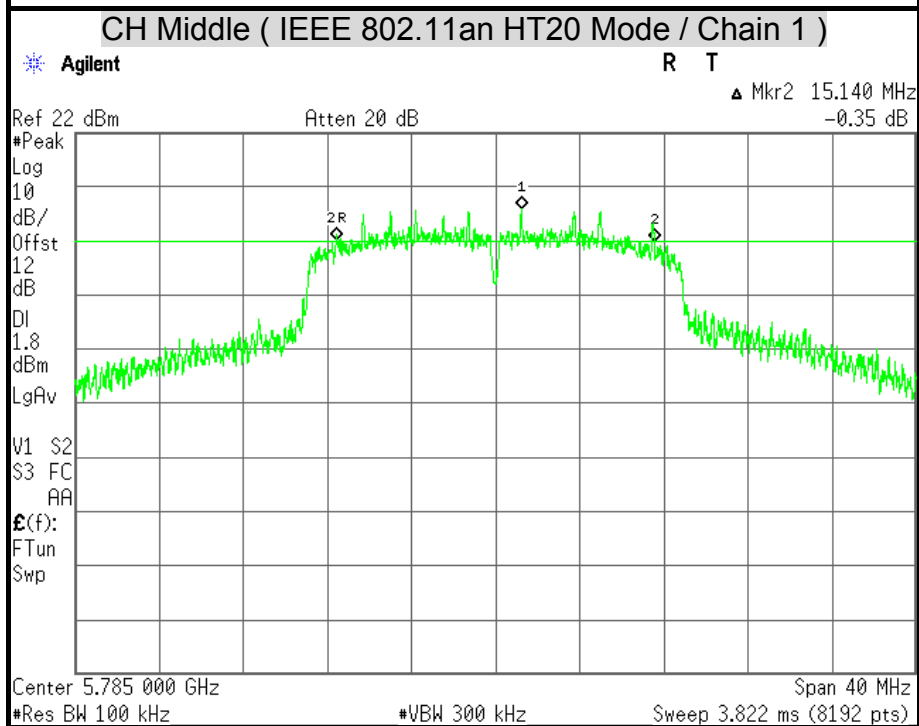
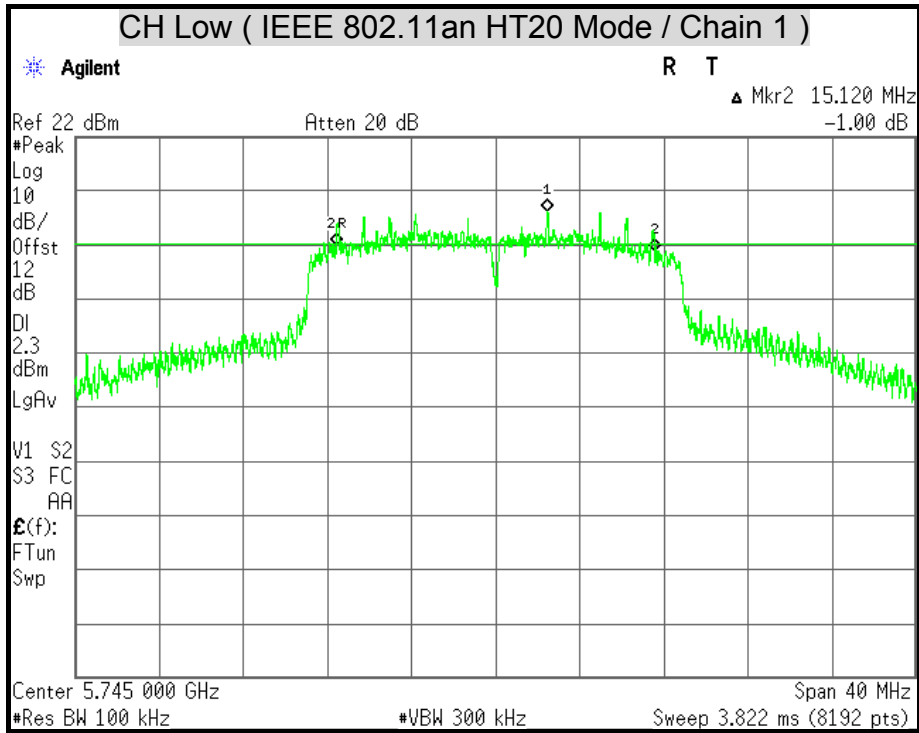

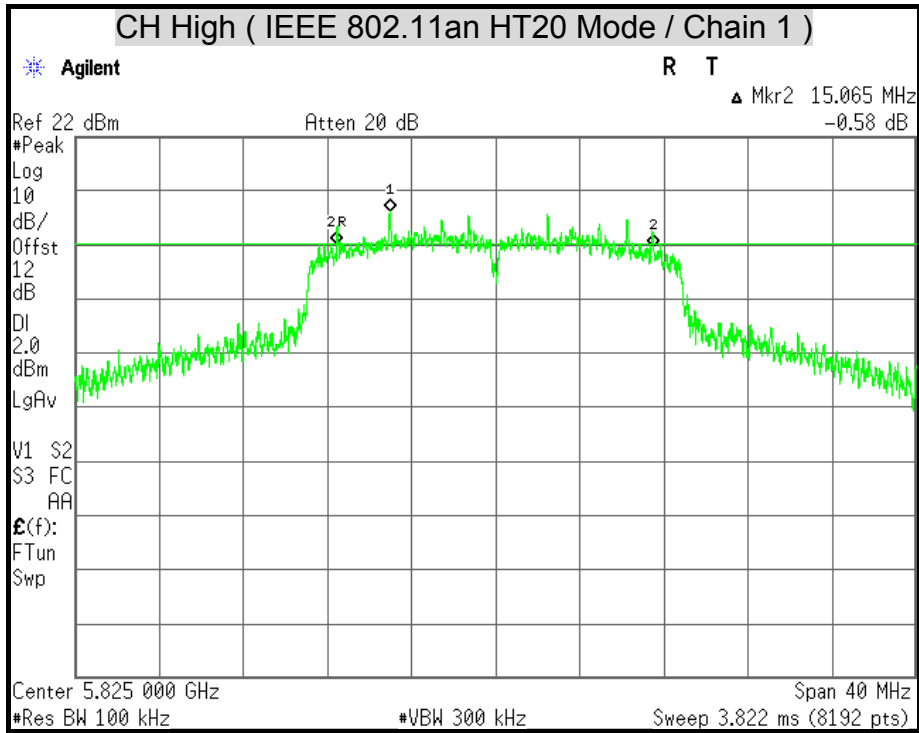

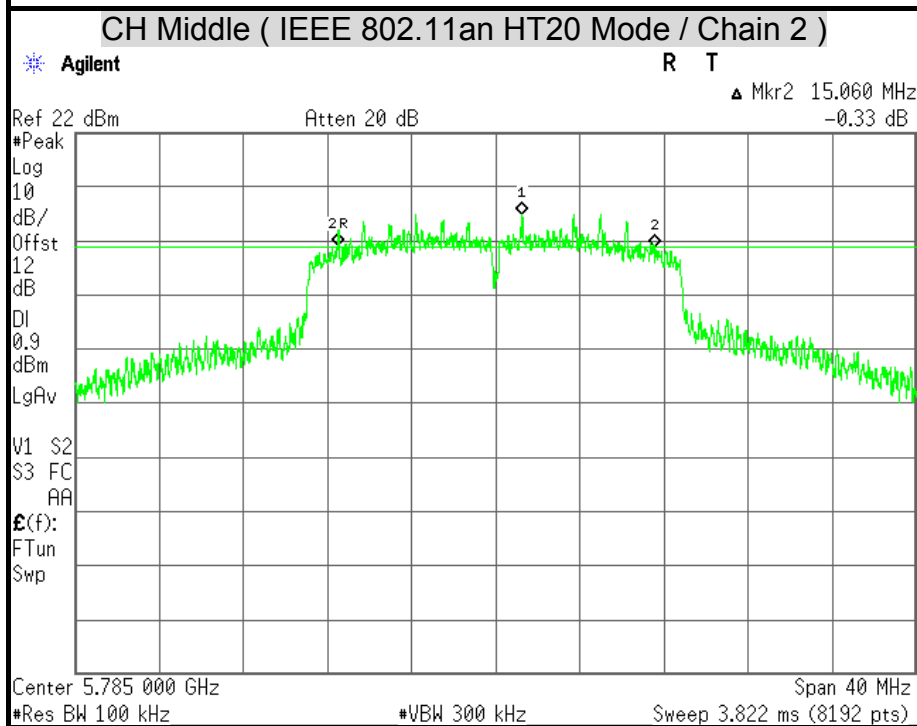
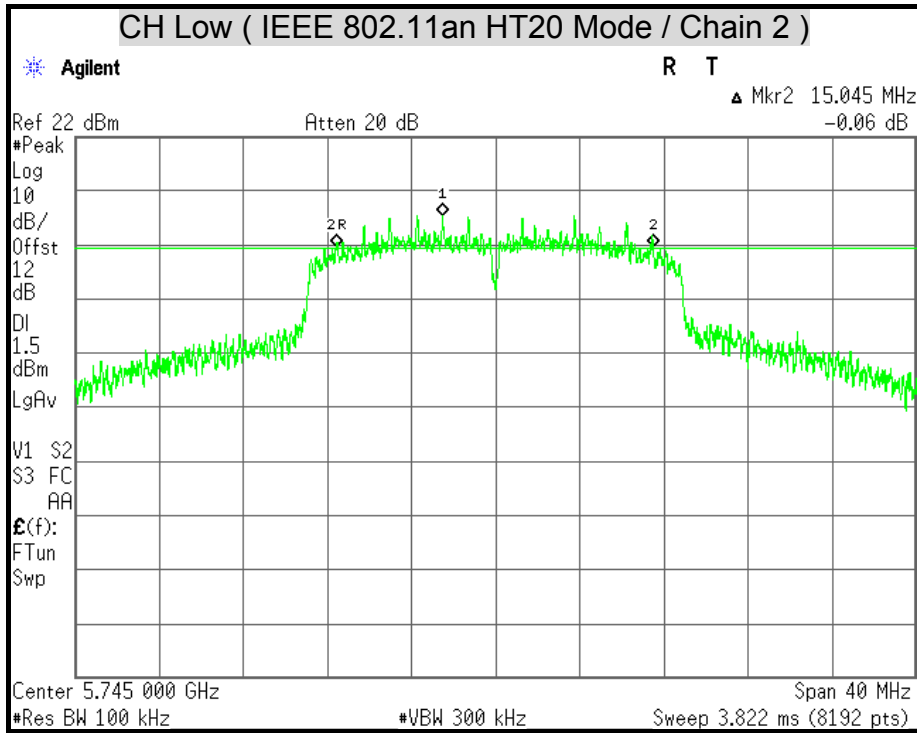

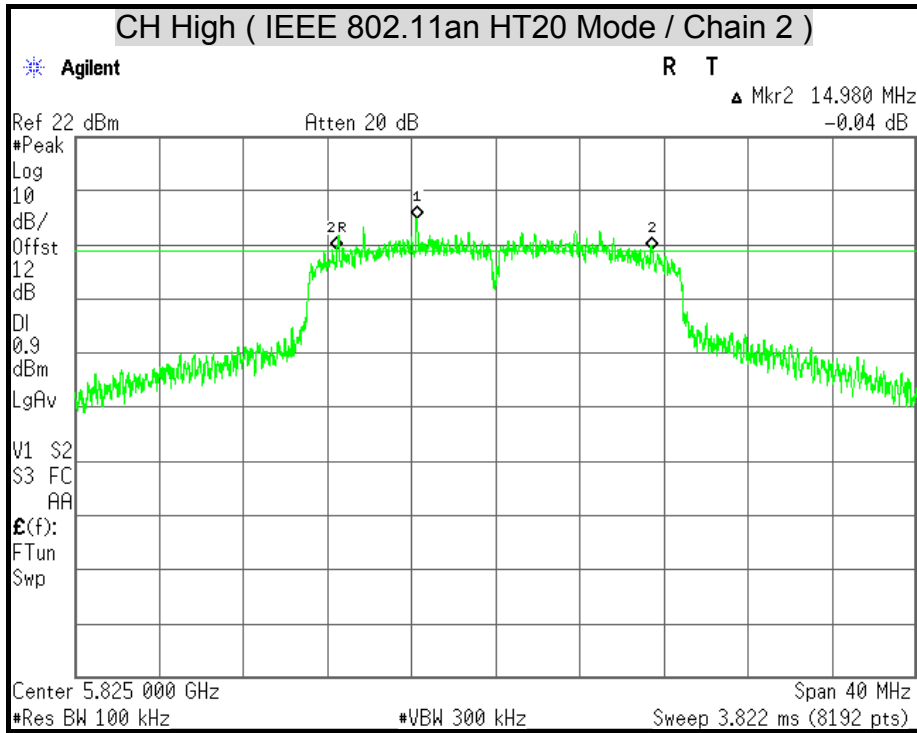

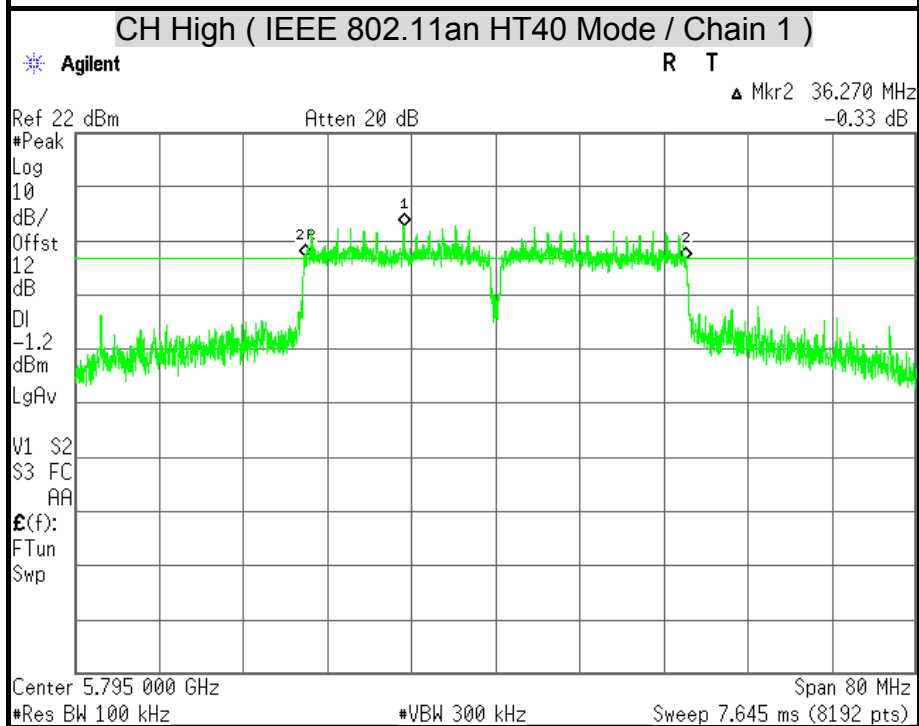
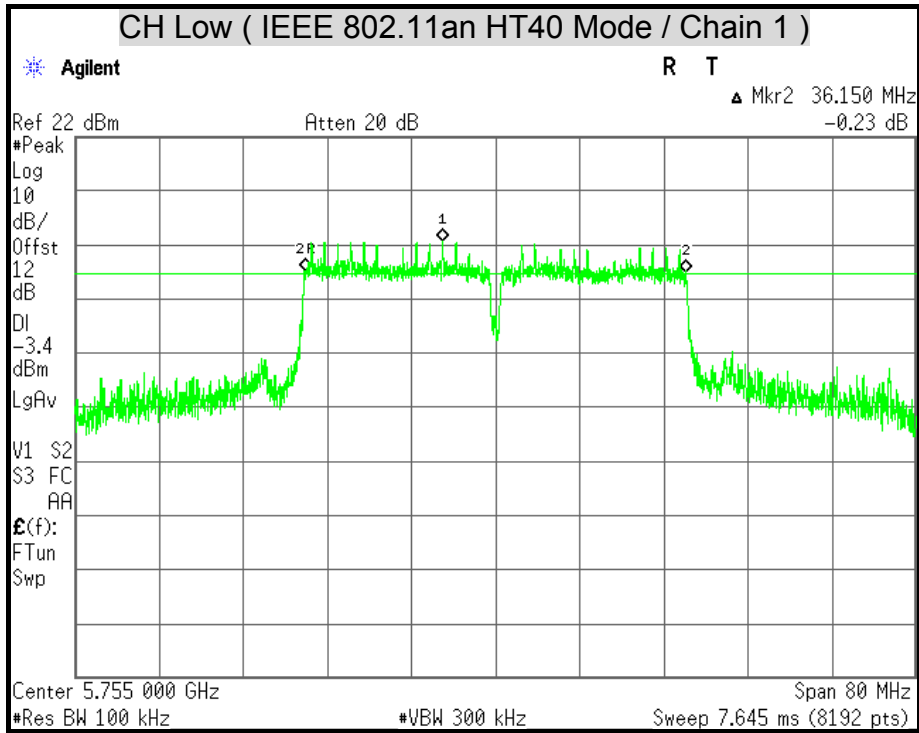

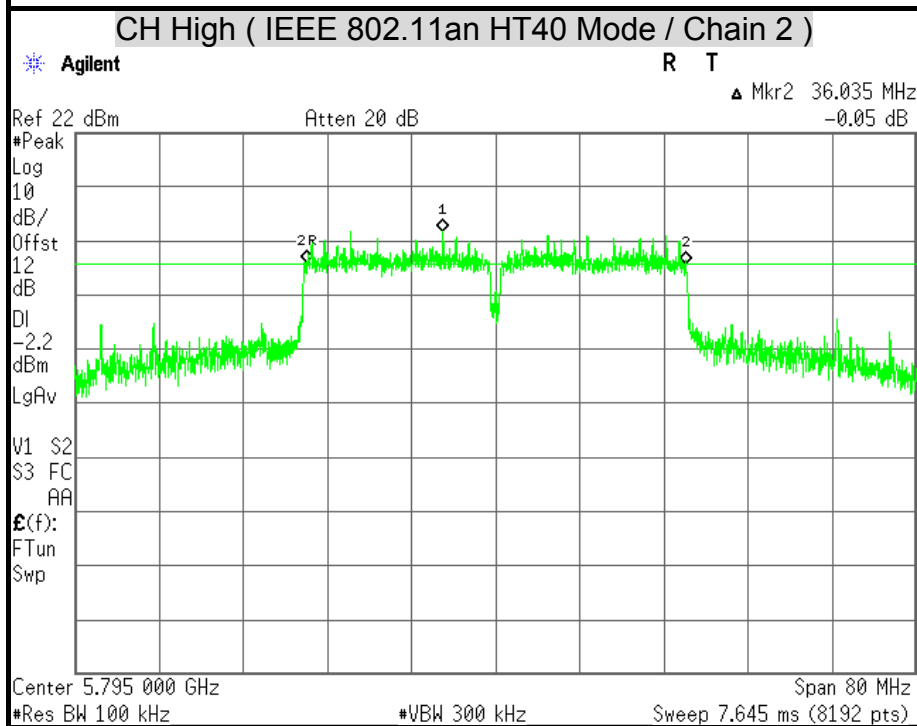
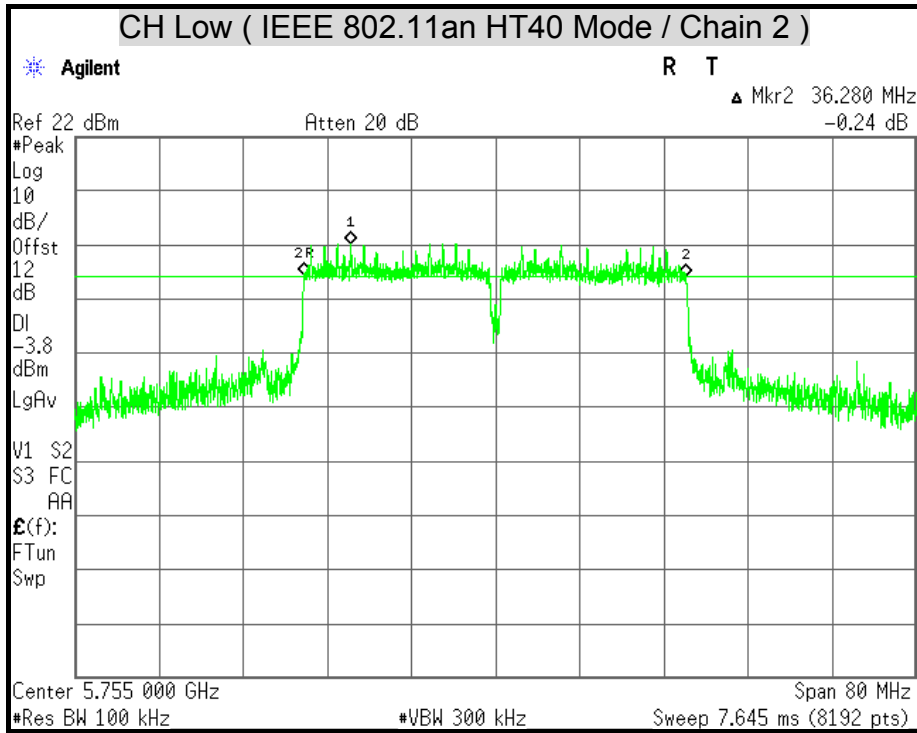

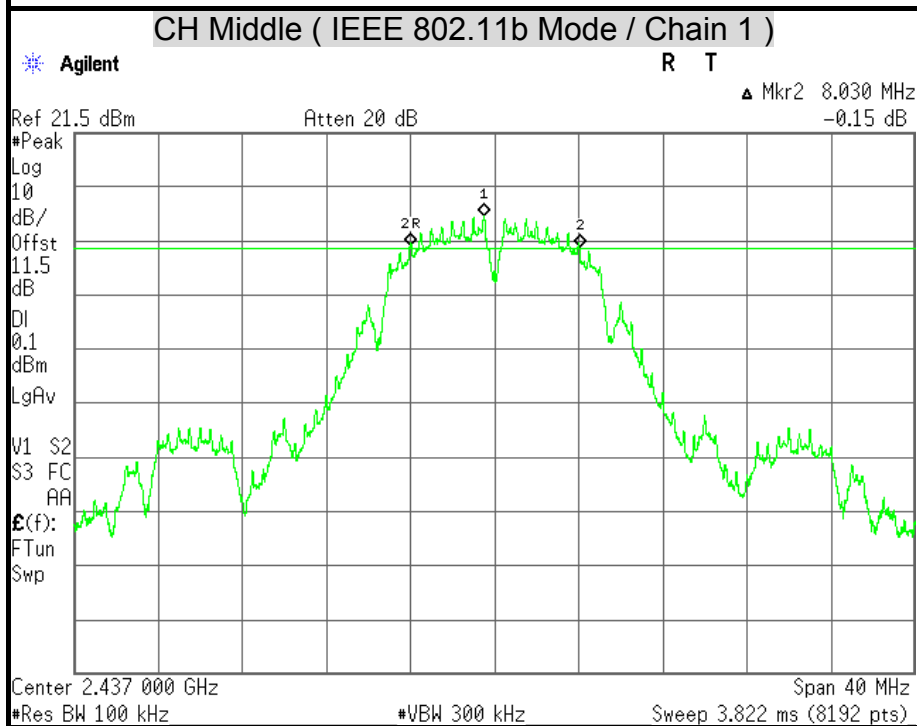
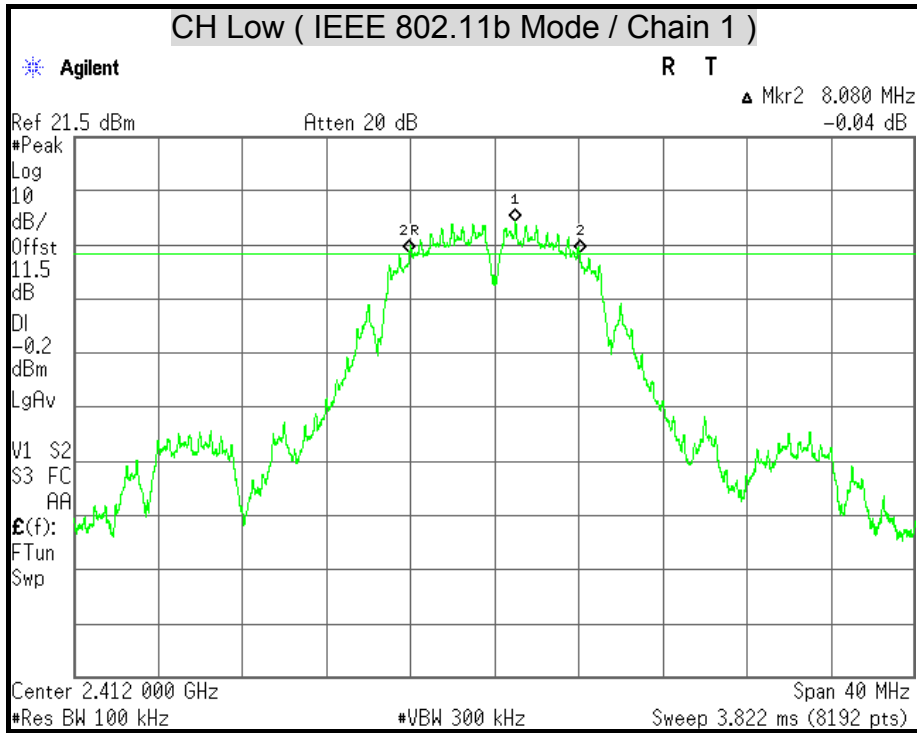

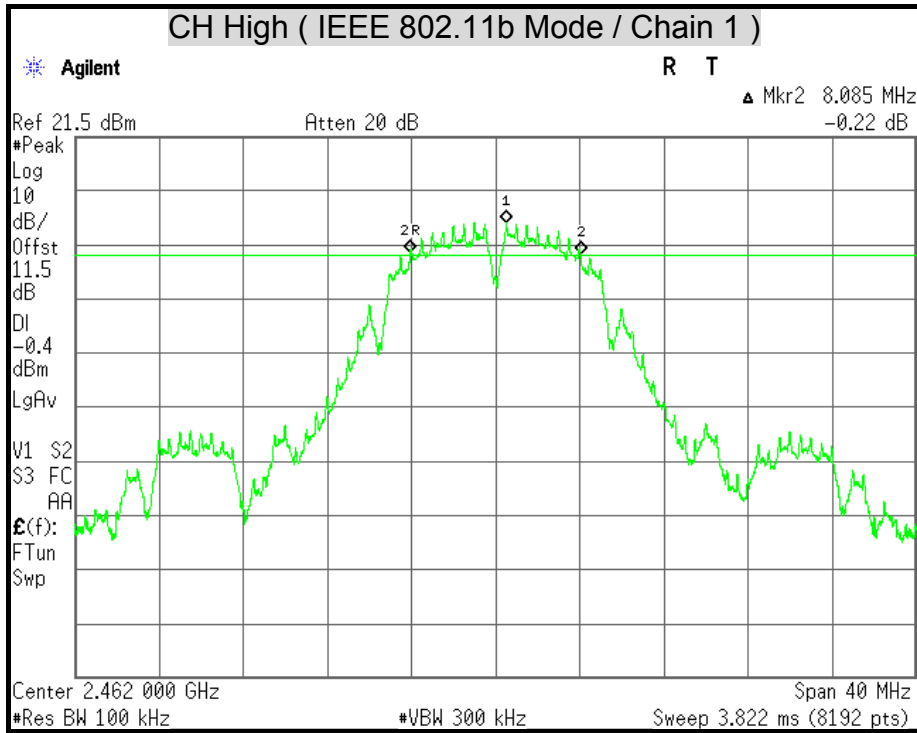

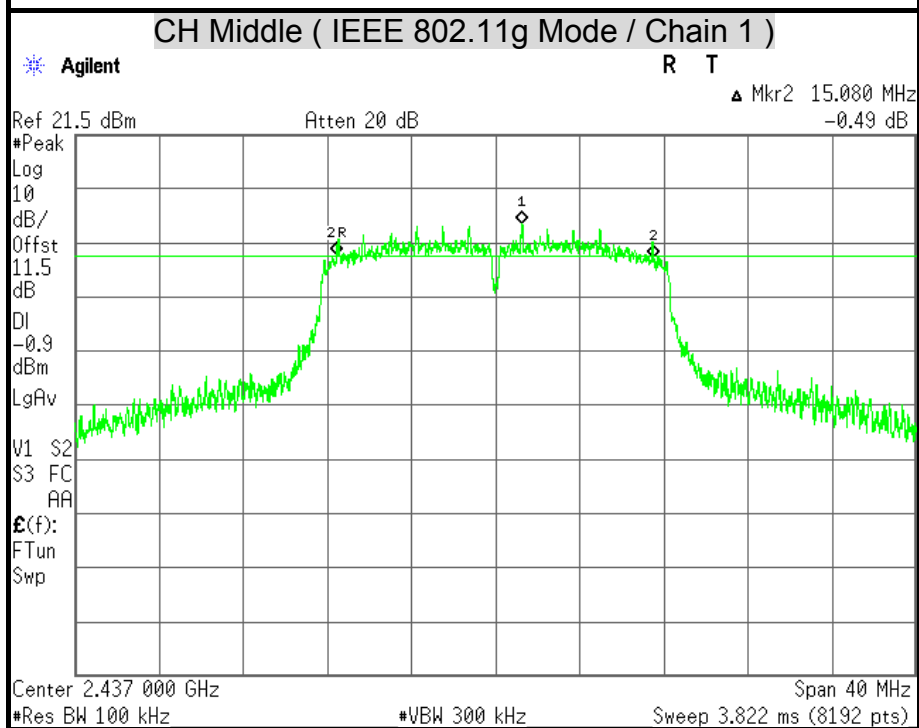
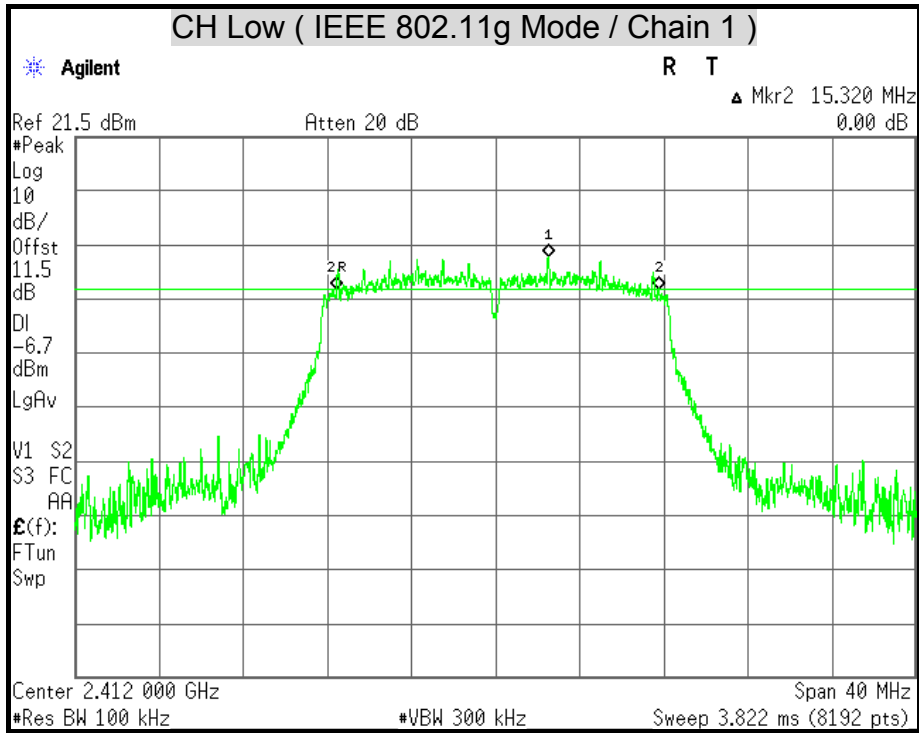

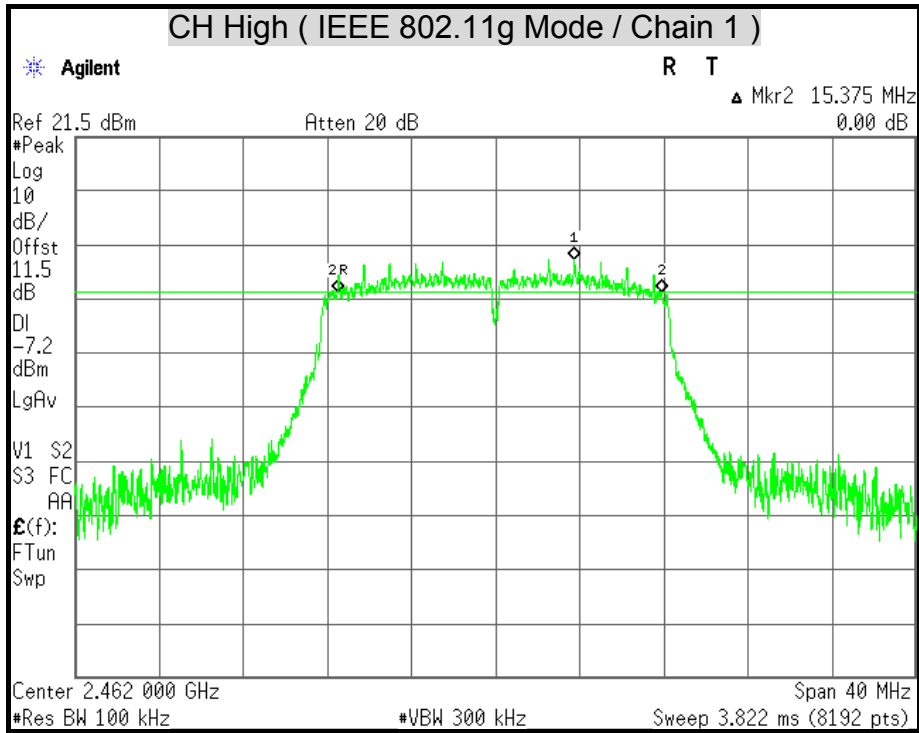

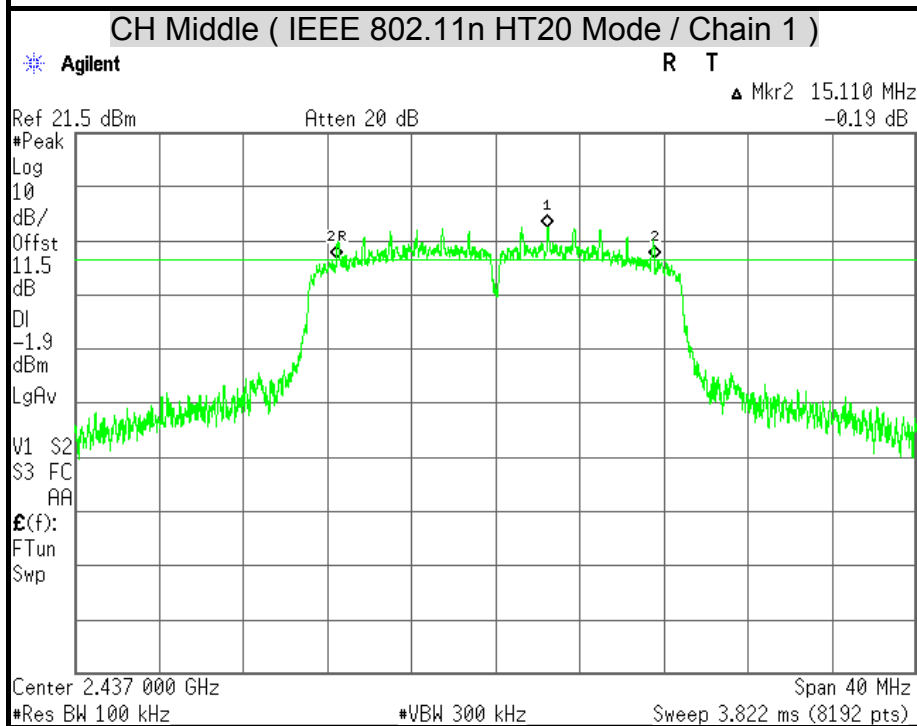
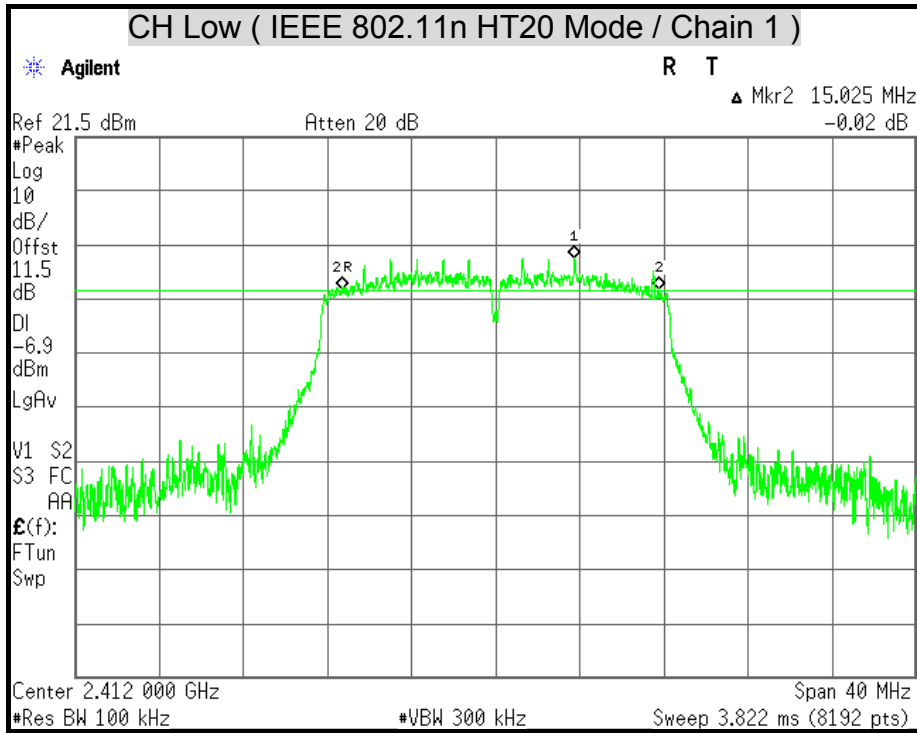

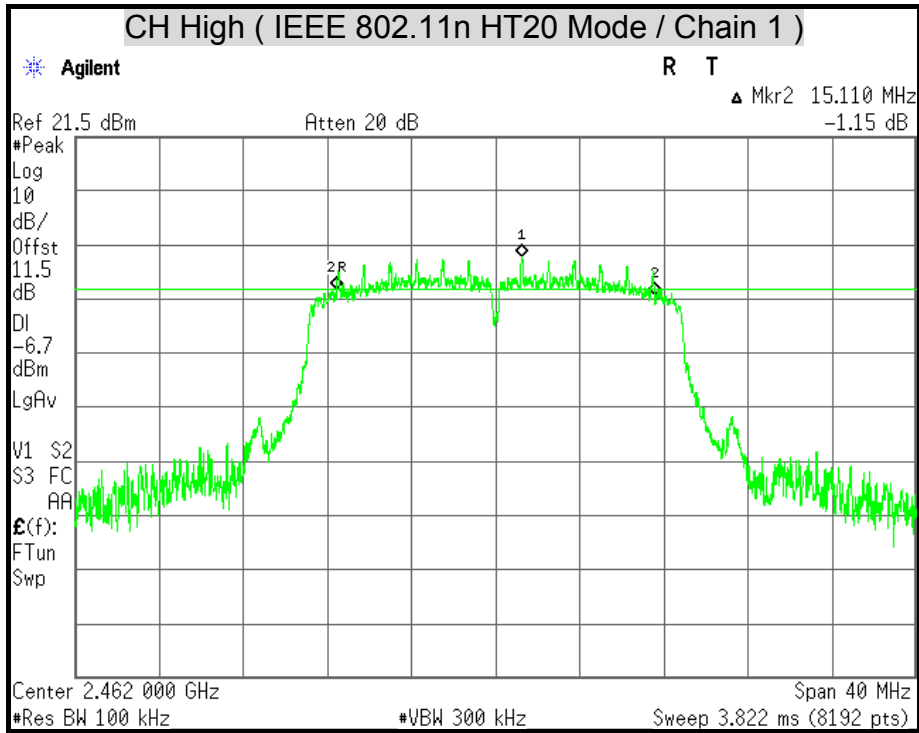

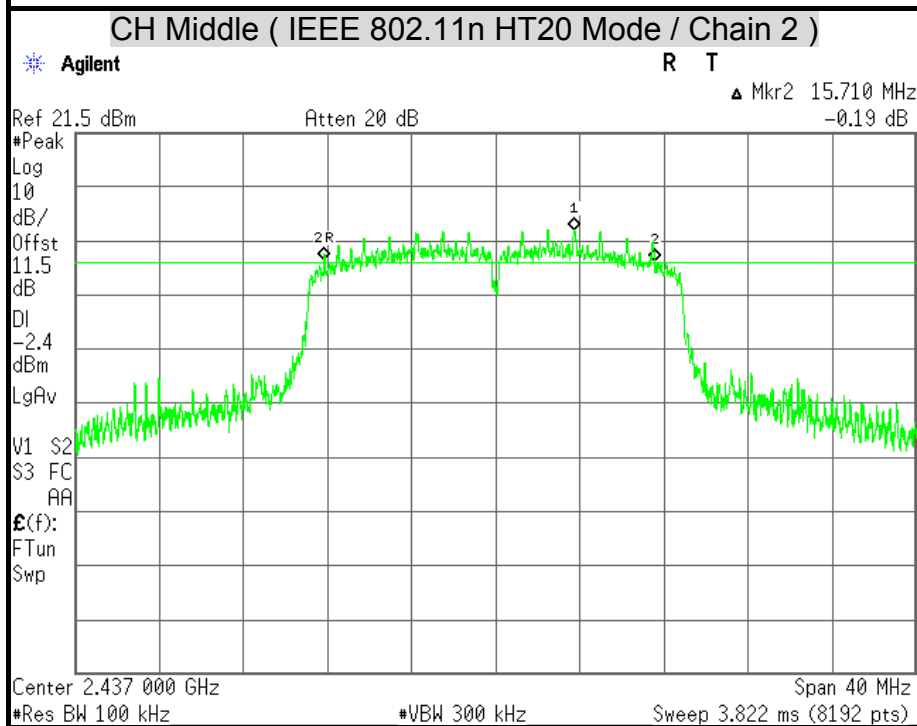
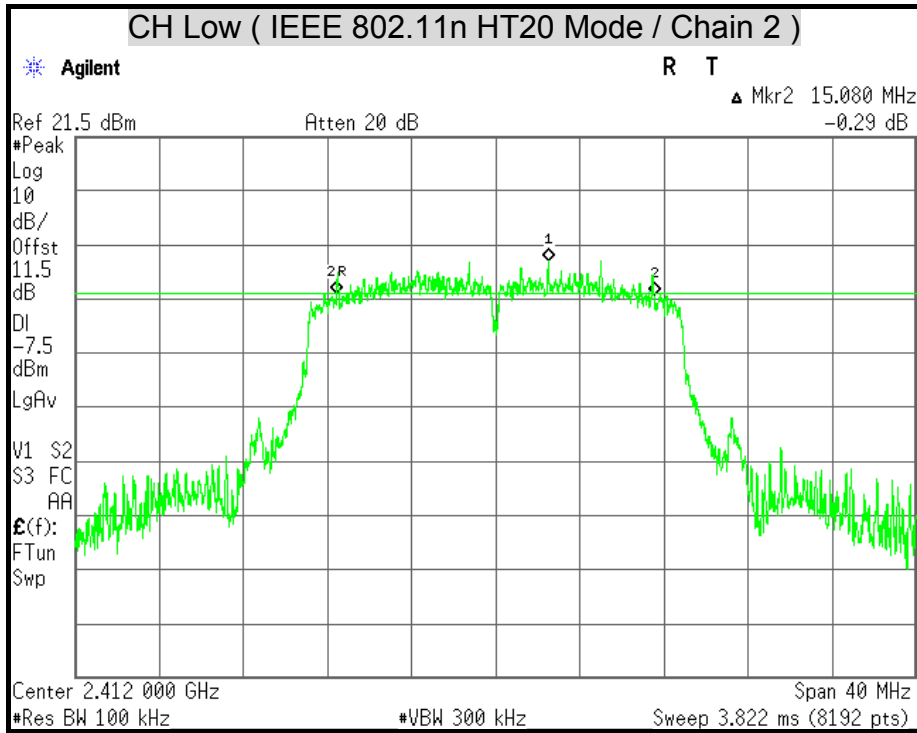

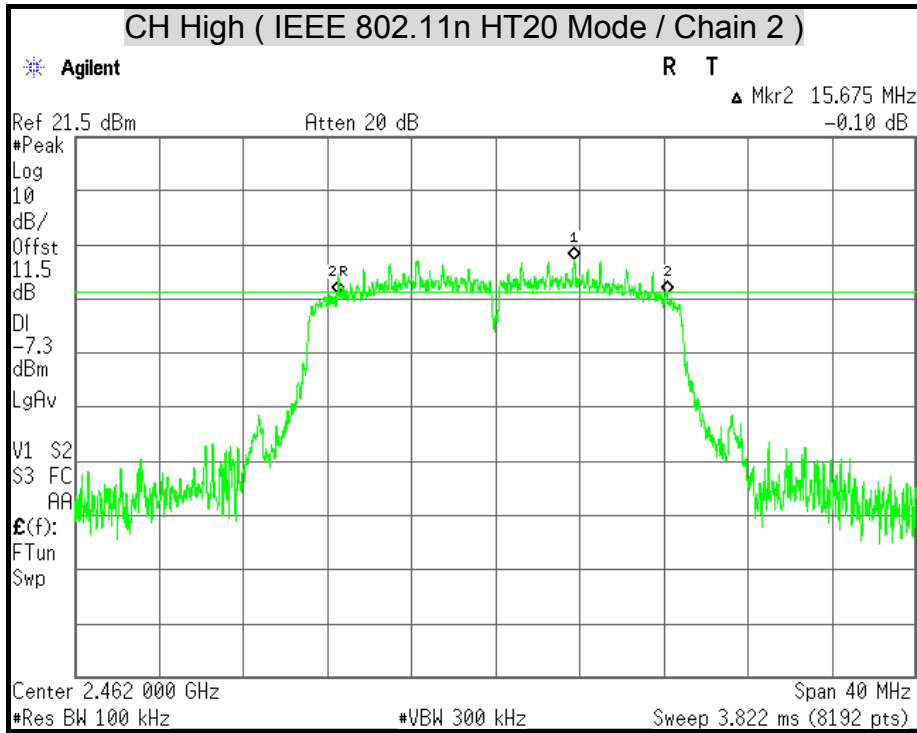

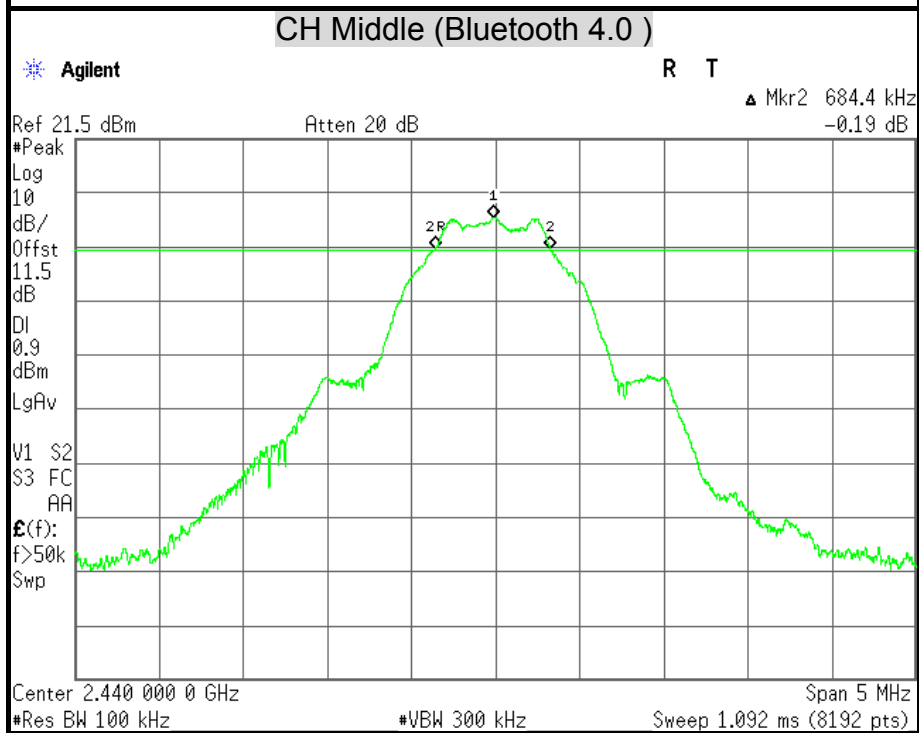
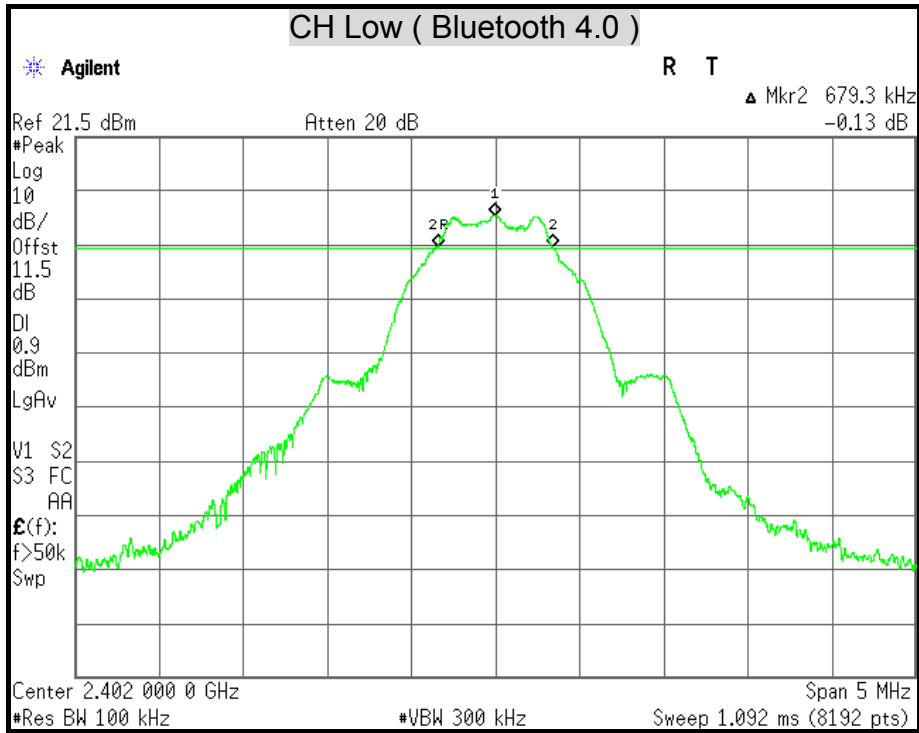

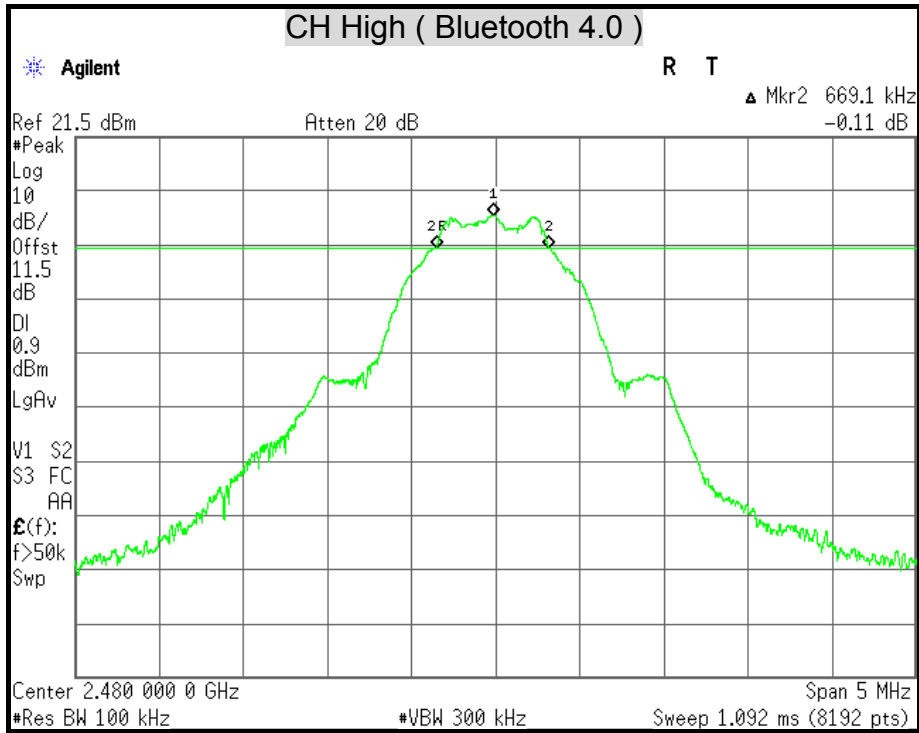



7.2 MAXIMUM PEAK OUTPUT POWER

LIMITS

§ 15.247(b) The maximum peak output power of the intentional radiator shall not exceed the following :

§ 15.247(b) (3) For systems using digital modulation in the 902-928 MHz, 2400-2483.5 MHz, and 5725-5850 MHz bands : 1 watt.

§ 15.247(b) (4) Except as shown in paragraphs (c) of this section, if transmitting antennas of directional gain greater than 6 dBi are used the peak output power from the intentional radiator shall be reduced below the stated values in paragraphs (b)(1) or (b)(2), and (b)(3) of this section, as appropriate, by the amount in dB that the directional gain of the antenna exceeds 6 dBi.

TEST EQUIPMENT

Name of Equipment	Manufacturer	Model	Serial Number	Calibration Due
Power Meter	Anritsu	ML2495A	1149001	12/06/2013
Power Sensor	Anritsu	MA2411B	1126148	12/07/2013

Remark: Each piece of equipment is scheduled for calibration once a year.

TEST SETUP

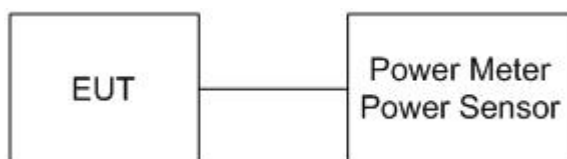

TEST PROCEDURE

The transmitter output is connected to the Power Meter. The Power Meter is set to the peak power detection.



TEST RESULTS

IEEE 802.11a Mode

Channel	Channel Frequency (MHz)	Peak Power		Peak Power Limit		Pass / Fail
		Chain 1		(dBm)	(W)	
		(dBm)	(W)			
Low	5745	24.86	0.3061	30	1	PASS
Middle	5785	24.61	0.2893	30	1	PASS
High	5825	24.69	0.2944	30	1	PASS

Remark:

1. At final test to get the worst-case emission at 6Mbps.
2. The cable assembly insertion loss of 12 dB (including 10 dB pad and 2 dB cable) was Entered as an offset in the power meter to allow for direct reading of power.

IEEE 802.11an HT20 Mode (Two TX)

Channel	Channel Frequency (MHz)	Peak Power (dBm)		Peak Power Total		Peak Power Limit		Pass / Fail
		Chain 1	Chain 2	(dBm)	(W)	(dBm)	(W)	
Low	5745	24.75	24.55	27.66	0.5837	30	0.955	PASS
Middle	5785	24.16	23.99	27.08	0.5110	30	0.955	PASS
High	5825	24.57	23.61	27.12	0.5158	30	0.955	PASS

Remark:

1. At final test to get the worst-case emission at 13Mbps.
2. The cable assembly insertion loss of 12 dB (including 10 dB pad and 2 dB cable) was Entered as an offset in the power meter to allow for direct reading of power.
3. Array gain = 0 dB for $N_{ANT} \leq 4$, power limit do not reduce.
4. Total peak power = Chain 1 + Chain 2.

IEEE 802.11an HT40 Mode (Two TX)

Channel	Channel Frequency (MHz)	Peak Power (dBm)		Peak Power Total		Peak Power Limit		Pass / Fail
		Chain 1	Chain 2	(dBm)	(W)	(dBm)	(W)	
Low	5755	23.00	22.86	25.94	0.3925	30	0.955	PASS
High	5815	24.95	24.20	27.60	0.5751	30	0.955	PASS

Remark:

1. At final test to get the worst-case emission at 27Mbps.
2. The cable assembly insertion loss of 12 dB (including 10 dB pad and 2 dB cable) was Entered as an offset in the power meter to allow for direct reading of power.
3. Array gain = 0 dB for $N_{ANT} \leq 4$, power limit do not reduce.
4. Total peak power = Chain 1 + Chain 2.



IEEE 802.11b Mode

Channel	Channel Frequency (MHz)	Peak Power		Peak Power Limit		Pass / Fail
		Chain 1		(dBm)	(W)	
		(dBm)	(W)			
Low	2412	16.84	0.0483	30	1	PASS
Middle	2437	16.84	0.0483	30	1	PASS
High	2462	16.23	0.0420	30	1	PASS

Remark:

1. At final test to get the worst-case emission at 1Mbps.
2. The cable assembly insertion loss of 11.5 dB (including 10 dB pad and 1.5 dB cable) was Entered as an offset in the power meter to allow for direct reading of power.

IEEE 802.11g Mode

Channel	Channel Frequency (MHz)	Peak Power		Peak Power Limit		Pass / Fail
		Chain 1		(dBm)	(W)	
		(dBm)	(W)			
Low	2412	17.10	0.0512	30	1	PASS
Middle	2437	22.77	0.1891	30	1	PASS
High	2462	17.14	0.0518	30	1	PASS

Remark:

1. At final test to get the worst-case emission at 6Mbps.
2. The cable assembly insertion loss of 11.5 dB (including 10 dB pad and 1.5 dB cable) was Entered as an offset in the power meter to allow for direct reading of power.

IEEE 802.11n HT20 Mode (Two TX)

Channel	Channel Frequency (MHz)	Peak Power (dBm)		Peak Power Total		Peak Power Limit		Pass / Fail
		Chain 1	Chain 2	(dBm)	(W)	(dBm)	(W)	
Low	2412	17.23	17.25	20.25	0.1059	30	1	PASS
Middle	2437	21.61	21.72	24.68	0.2936	30	1	PASS
High	2462	16.96	16.86	19.92	0.0982	30	1	PASS

Remark:

1. At final test to get the worst-case emission at 13Mbps.
2. The cable assembly insertion loss of 11.5 dB (including 10 dB pad and 1.5 dB cable) was Entered as an offset in the power meter to allow for direct reading of power.
3. Array gain = 0 dB for $N_{ANT} \leq 4$, power limit do not reduce.
4. Total peak power = Chain 1 + Chain 2.



Bluetooth 4.0 Mode

Channel	Channel Frequency (MHz)	Peak Power		Peak Power Limit		Pass / Fail
		Chain 1		(dBm)	(W)	
		(dBm)	(W)			
Low	2402	7.59	0.0057	30	1	PASS
Middle	2440	7.70	0.0059	30	1	PASS
High	2480	7.64	0.0058	30	1	PASS

Remark: The cable assembly insertion loss of 11.5dB (including 10 dB pad and 1.5 dB cable) was Entered as an offset in the power meter to allow for direct reading of power.



7.3 AVERAGE POWER

LIMITS

None; for reporting purposes only.

TEST EQUIPMENT

Name of Equipment	Manufacturer	Model	Serial Number	Calibration Due
Power Meter	ANRITSU	ML2495A	1149001	12/06/2013
Power Sensor	ANRITSU	MA2411B	1126148	12/07/2013

Remark: Each piece of equipment is scheduled for calibration once a year.

TEST SETUP



TEST PROCEDURE

The transmitter output is connected to the Power Meter. The Power Meter is set to the peak power detection.



TEST RESULTS

IEEE 802.11a Mode

Channel	Channel Frequency (MHz)	Average Power (dBm)
		Chain 1
Low	5745	18.19
Middle	5785	17.92
High	5825	18.10

Remark:

1. At final test to get the worst-case emission at 6Mbps.
2. The cable assembly insertion loss of 12 dB (including 10 dB pad and 2 dB cable) was Entered as an offset in the power meter to allow for direct reading of power.

IEEE 802.11an HT20 Mode (Two TX)

Channel	Channel Frequency (MHz)	Average Power (dBm)		Average Power Total (dBm)
		Chain 1	Chain 2	
Low	5745	17.87	17.33	20.62
Middle	5785	17.39	16.92	20.17
High	5825	17.72	16.48	20.16

Remark:

1. At final test to get the worst-case emission at 13Mbps.
2. The cable assembly insertion loss of 12 dB (including 10 dB pad and 2 dB cable) was Entered as an offset in the power meter to allow for direct reading of power.
3. Total AVG power = Chain 1 + Chain 2

IEEE 802.11an HT40 Mode (Two TX)

Channel	Channel Frequency (MHz)	Average Power (dBm)		Average Power Total (dBm)
		Chain 1	Chain 2	
Low	5755	15.90	15.38	18.66
High	5795	17.76	16.60	20.23

Remark:

1. At final test to get the worst-case emission at 27Mbps.
2. The cable assembly insertion loss of 12 dB (including 10 dB pad and 2 dB cable) was Entered as an offset in the power meter to allow for direct reading of power.
3. Total AVG power = Chain 1 + Chain 2.



IEEE 802.11b Mode

Channel	Channel Frequency (MHz)	Average Power (dBm)
		Chain 1
Low	2412	13.87
Middle	2437	13.88
High	2462	13.27

Remark:

1. At final test to get the worst-case emission at 1Mbps.
2. The cable assembly insertion loss of 11.5 dB (including 10 dB pad and 1.5 dB cable) was Entered as an offset in the power meter to allow for direct reading of power.

IEEE 802.11g Mode

Channel	Channel Frequency (MHz)	Average Power (dBm)
		Chain 1
Low	2412	9.80
Middle	2437	15.37
High	2462	9.79

Remark:

1. At final test to get the worst-case emission at 6Mbps.
2. The cable assembly insertion loss of 11.5 dB (including 10 dB pad and 1.5 dB cable) was Entered as an offset in the power meter to allow for direct reading of power.

IEEE 802.11n HT20 Mode (Two TX)

Channel	Channel Frequency (MHz)	Average Power (dBm)		Average Power Total (dBm)
		Chain 1	Chain 2	
Low	2412	9.87	9.33	12.62
Middle	2437	14.13	13.73	16.95
High	2462	9.37	8.90	12.15

Remark:

1. At final test to get the worst-case emission at 13Mbps.
2. The cable assembly insertion loss of 11.5 dB (including 10 dB pad and 1.5 dB cable) was Entered as an offset in the power meter to allow for direct reading of power.
3. Total AVG power = Chain 1 + Chain 2.



Bluetooth 4.0 Mode

Channel	Channel Frequency (MHz)	Average Power (dBm)
		Chain 1
Low	2402	7.45
Middle	2440	7.58
High	2480	7.47

Remark: The cable assembly insertion loss of 11.5dB (including 10 dB pad and 1.5 dB cable) was Entered as an offset in the power meter to allow for direct reading of power.



7.4 POWER SPECTRAL DENSITY

LIMITS

§ 15.247(e) For digitally modulated systems, the power spectral density conducted from the intentional radiator to the antenna shall not greater than 8 dBm in any 3 kHz band during any time interval of continuous transmission.

TEST EQUIPMENT

Name of Equipment	Manufacturer	Model	Serial Number	Calibration Due
Spectrum Analyzer	Agilent	E4446A	MY43360132	06/10/2014

Remark: Each piece of equipment is scheduled for calibration once a year.

TEST SETUP



TEST PROCEDURE

1. The transmitter output was connected to the spectrum analyzer.
2. Set analyzer center frequency to DTS channel center frequency.
3. Set the span to 1.5 times the DTS channel bandwidth.
4. Set the RBW to: $3 \text{ kHz} \leq \text{RBW} \leq 100 \text{ kHz}$.
5. Set the VBW $\geq 3 \times \text{RBW}$.
6. Detector = peak.
7. Sweep time = auto couple.
8. Trace mode = max hold.
9. Allow trace to fully stabilize.
10. Use the peak marker function to determine the maximum amplitude level within the RBW.
11. If measured value exceeds limit, reduce RBW (no less than 3 kHz) and repeat.



TEST RESULTS

IEEE 802.11a Mode

Channel	Channel Frequency (MHz)	Final RF Power Level in 3KHz BW (dBm)		Minimum Limit (dBm)	Pass / Fail
		Chain 1	Chain 2		
Low	5745	-6.19		8	PASS
Middle	5785	-5.88		8	PASS
High	5825	-5.08		8	PASS

Remark:

1. At final test to get the worst-case emission at 6Mbps.
2. The cable assembly insertion loss of 12 dB (including 10 dB pad and 2 dB cable) was Entered as an offset in the spectrum analyzer to allow for direct reading of power.

IEEE 802.11an HT20 Mode (Two TX)

Channel	Channel Frequency (MHz)	Final RF Power Level in 3KHz BW (dBm)		PSD Total (dBm)	Minimum Limit (dBm)	Pass / Fail
		Chain 1	Chain 2			
Low	5745	-6.25	-7.54	-3.84	7.8	PASS
Middle	5785	-7.40	-8.04	-4.70	7.8	PASS
High	5825	-5.13	-8.22	-3.40	7.8	PASS

Remark:

1. At final test to get the worst-case emission at 13Mbps.
2. The cable assembly insertion loss of 12 dB (including 10 dB pad and 2 dB cable) was Entered as an offset in the spectrum analyzer to allow for direct reading of power.
3. The maximum antenna gain is 6.2dBi which is more than 6dBi, the limit should be 7.8dBm.
4. Total power spectral density = Chain 1 + Chain 2.

IEEE 802.11an HT40 Mode (Two TX)

Channel	Channel Frequency (MHz)	Final RF Power Level in 3KHz BW (dBm)		PSD Total (dBm)	Minimum Limit (dBm)	Pass / Fail
		Chain 1	Chain 2			
Low	5755	-11.15	-13.01	-8.97	7.8	PASS
High	5795	-10.31	-11.34	-7.78	7.8	PASS

Remark:

1. At final test to get the worst-case emission at 27Mbps.
2. The cable assembly insertion loss of 12 dB (including 10 dB pad and 2 dB cable) was Entered as an offset in the spectrum analyzer to allow for direct reading of power.
3. The maximum antenna gain is 6.2dBi which is more than 6dBi, the limit should be 7.8dBm.
4. Total power spectral density = Chain 1 + Chain 2.



IEEE 802.11b Mode

Channel	Channel Frequency (MHz)	Final RF Power Level in 3KHz BW (dBm)	Minimum Limit (dBm)	Pass / Fail
		Chain 1		
Low	2412	-8.07	8	PASS
Middle	2437	-7.76	8	PASS
High	2462	-8.64	8	PASS

Remark:

1. At final test to get the worst-case emission at 1Mbps.
2. The cable assembly insertion loss of 11.5 dB (including 10 dB pad and 1.5 dB cable) was Entered as an offset in the spectrum analyzer to allow for direct reading of power.

IEEE 802.11g Mode

Channel	Channel Frequency (MHz)	Final RF Power Level in 3KHz BW (dBm)	Minimum Limit (dBm)	Pass / Fail
		Chain 1		
Low	2412	-15.36	8	PASS
Middle	2437	-8.75	8	PASS
High	2462	-15.48	8	PASS

Remark:

1. At final test to get the worst-case emission at 6Mbps.
2. The cable assembly insertion loss of 11.5 dB (including 10 dB pad and 1.5 dB cable) was Entered as an offset in the spectrum analyzer to allow for direct reading of power.



IEEE 802.11n HT20 Mode (Two TX)

Channel	Channel Frequency (MHz)	Final RF Power Level in 3KHz BW (dBm)		PSD Total (dBm)	Minimum Limit (dBm)	Pass / Fail
		Chain 1	Chain 2			
Low	2412	-14.47	-15.72	-12.04	8	PASS
Middle	2437	-10.93	-10.93	-7.92	8	PASS
High	2462	-14.61	-15.83	-12.17	8	PASS

Remark:

1. At final test to get the worst-case emission at 13Mbps.
2. The cable assembly insertion loss of 11.5 dB (including 10 dB pad and 1.5 dB cable) was Entered as an offset in the spectrum analyzer to allow for direct reading of power.
3. The maximum antenna gain is 5.76dBi which is less than 6dBi, the limit should be 8dBm.
4. Total power spectral density = Chain 1 + Chain 2.

Bluetooth 4.0 Mode

Channel	Channel Frequency (MHz)	Final RF Power Level in 3KHz BW (dBm)	Minimum Limit (dBm)	Pass / Fail
		Chain 1		
Low	2402	-7.04	8	PASS
Middle	2440	-6.89	8	PASS
High	2480	-6.98	8	PASS

Remark: The cable assembly insertion loss of 11.5 dB (including 10 dB pad and 1.5 dB cable) was Entered as an offset in the spectrum analyzer to allow for direct reading of power.



POWER SPECTRAL DENSITY

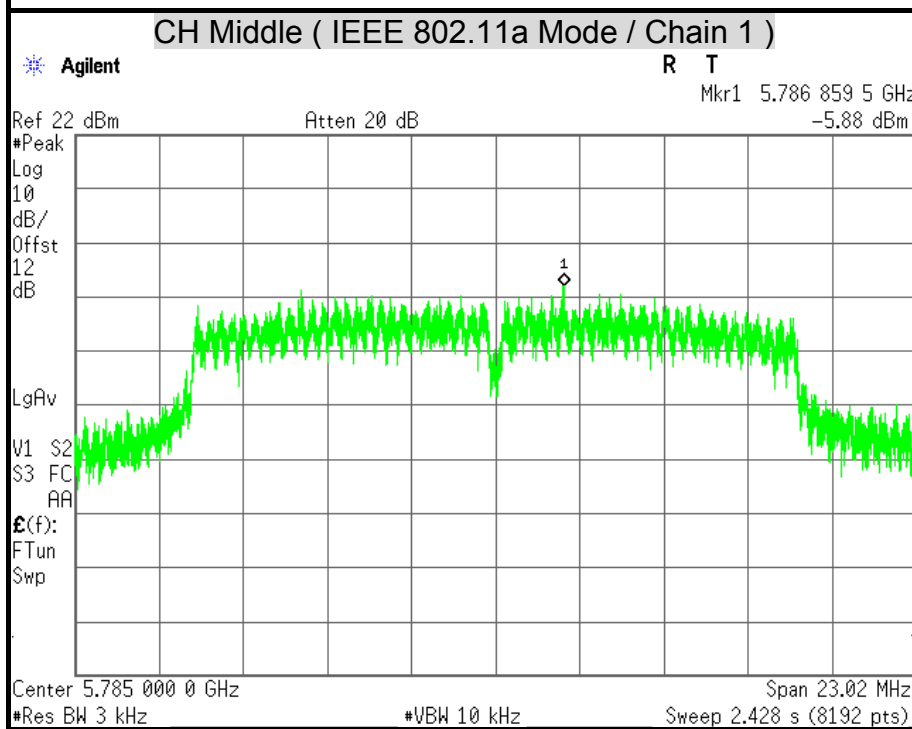
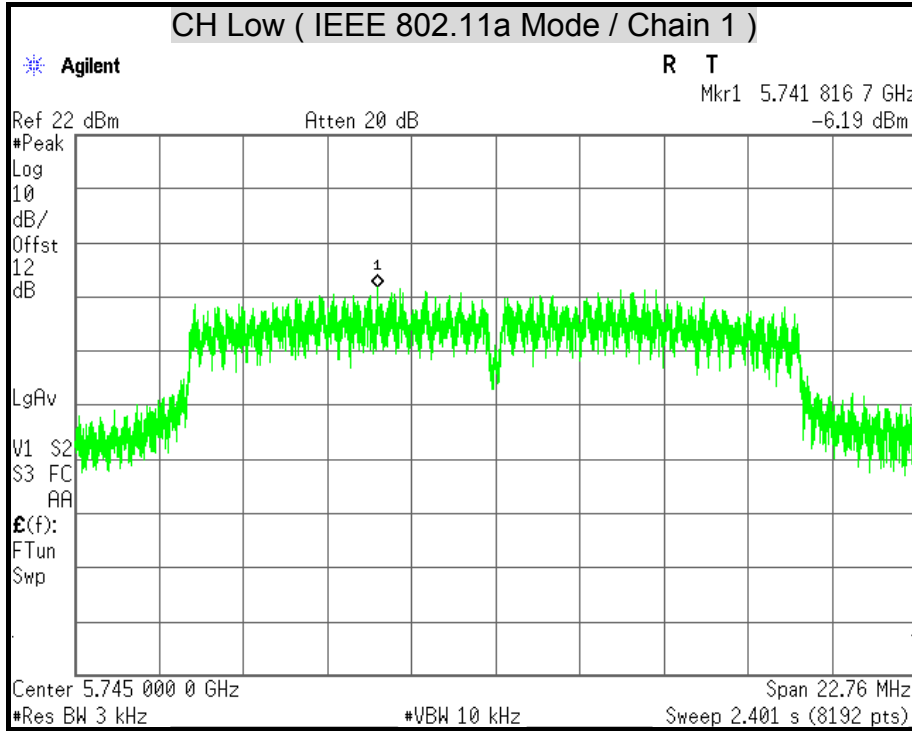

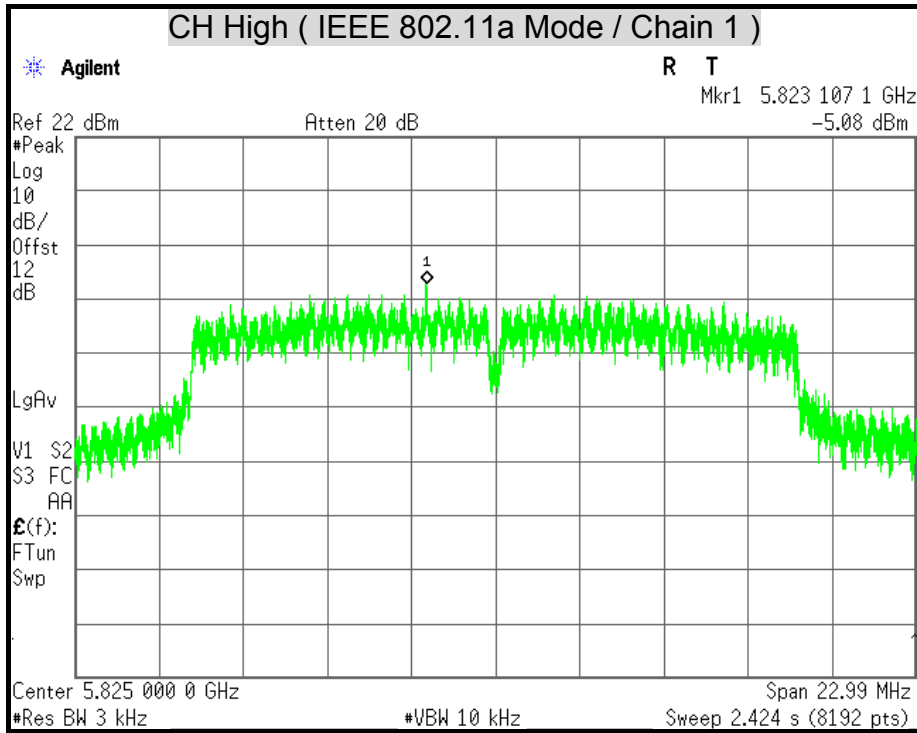

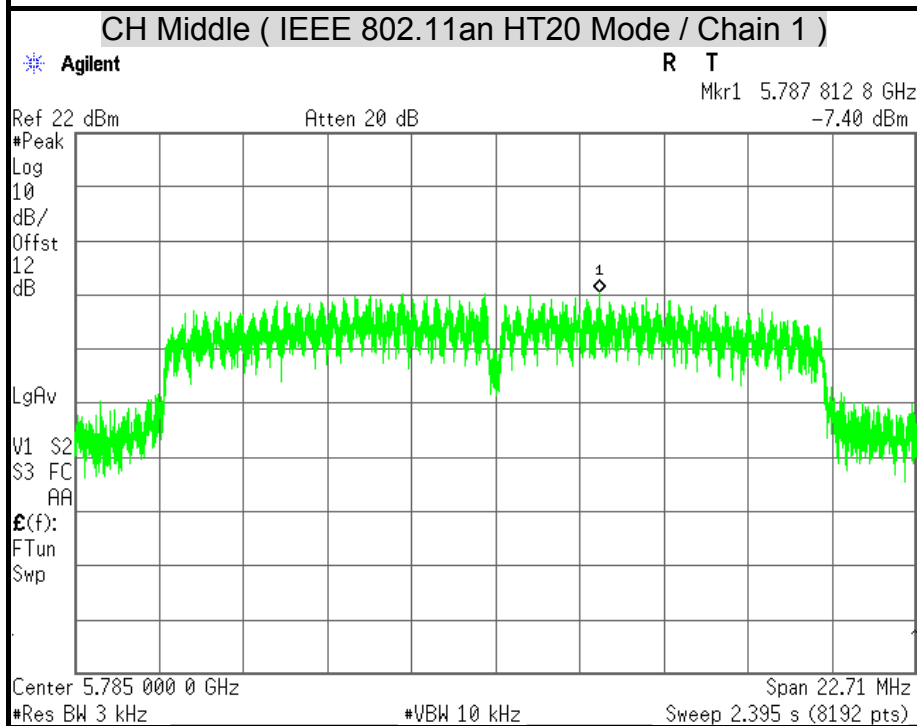
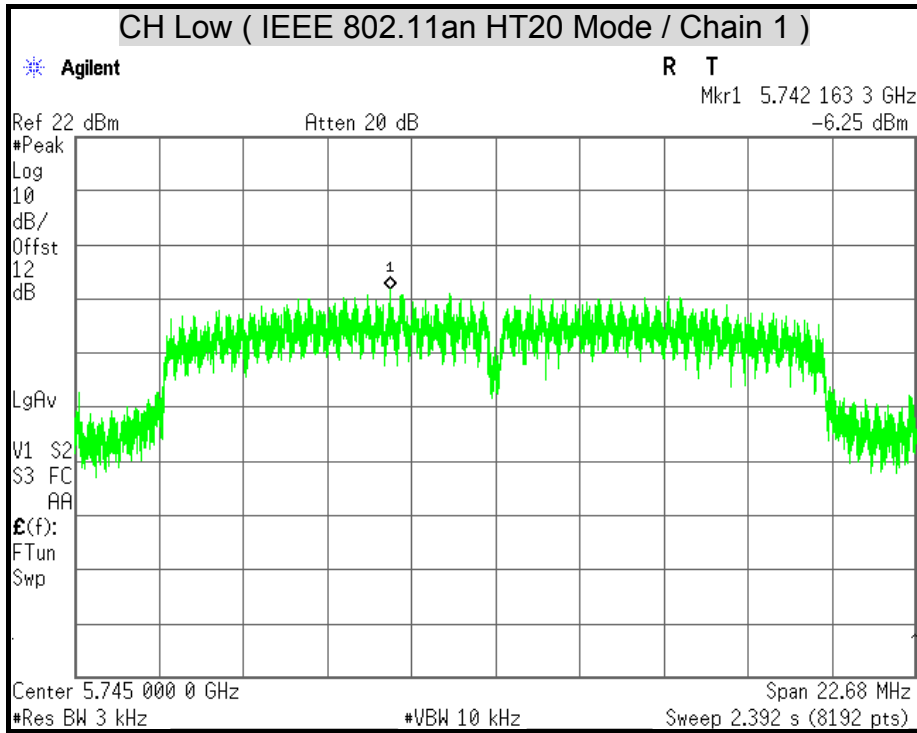

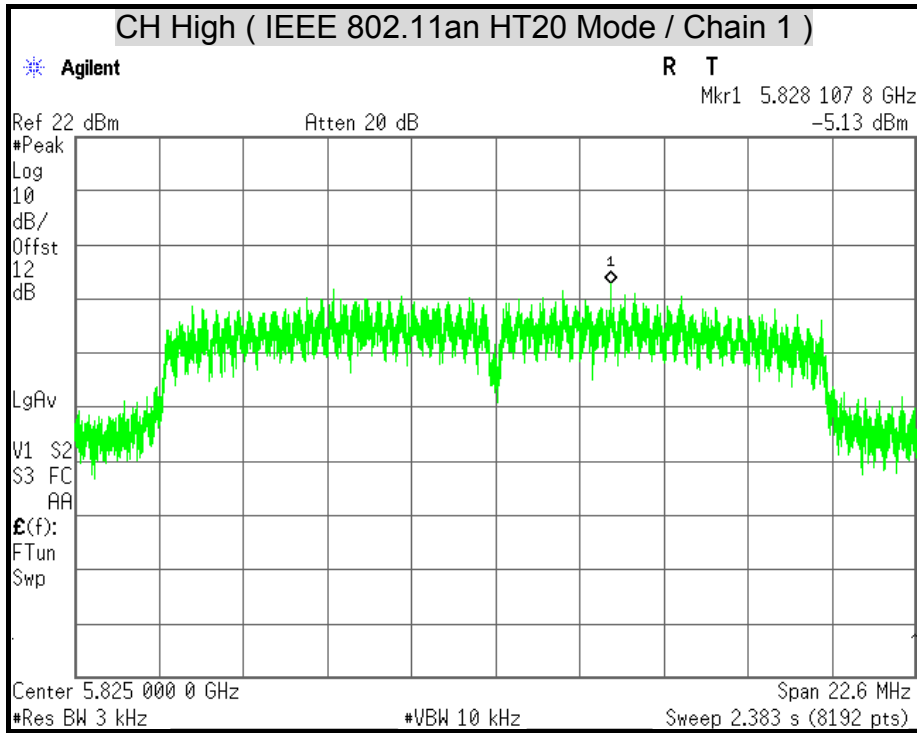

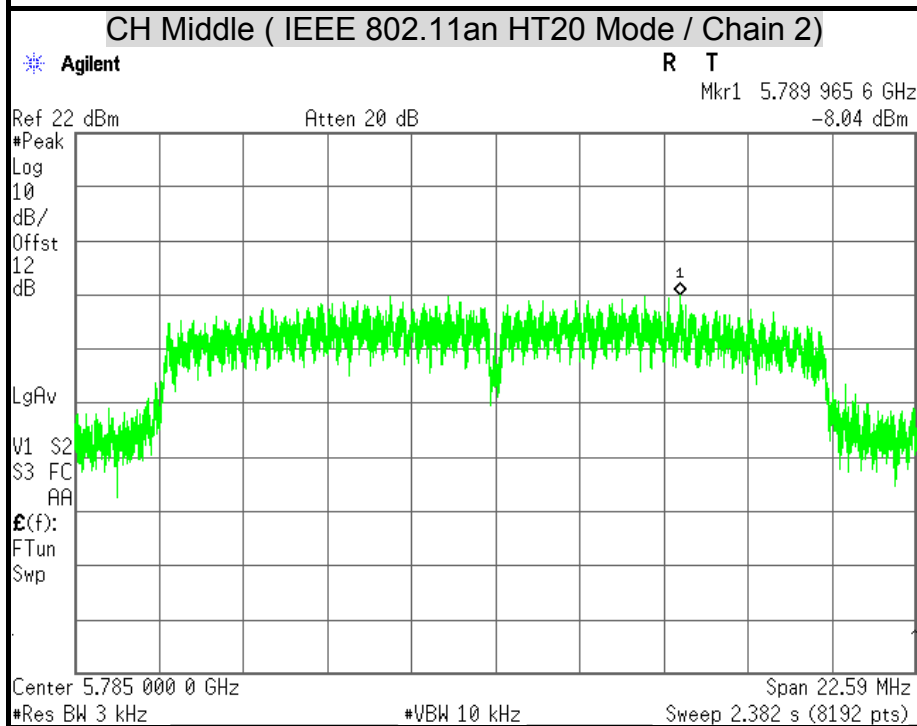
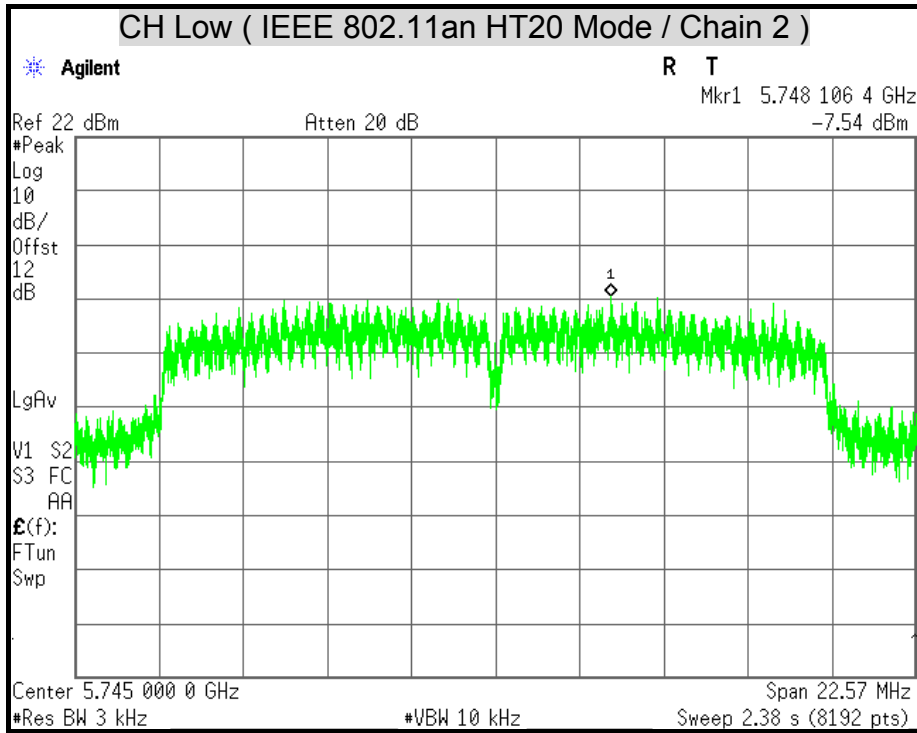

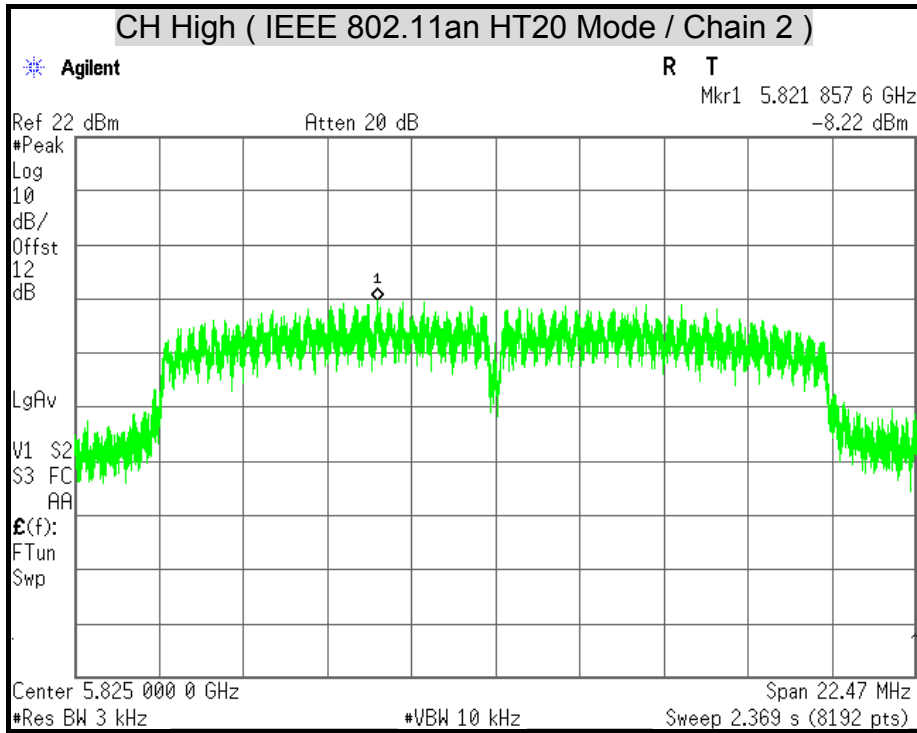

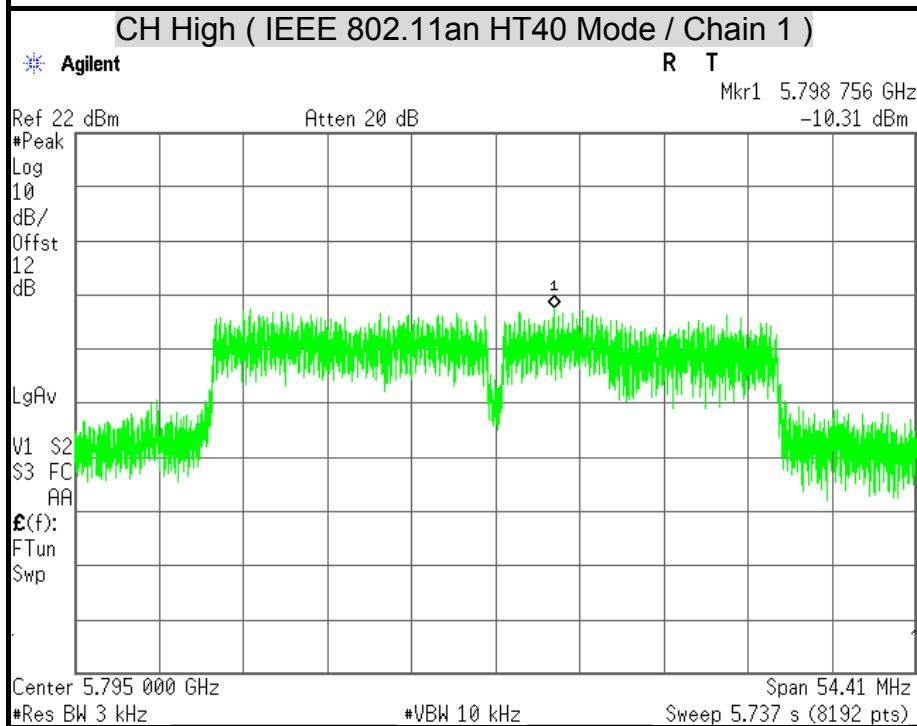
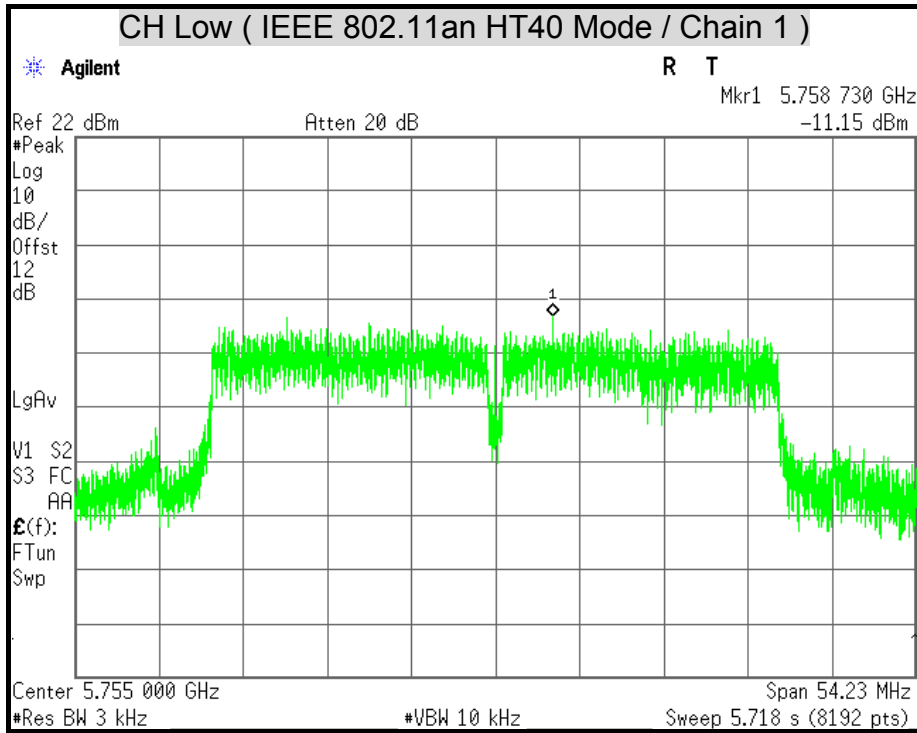

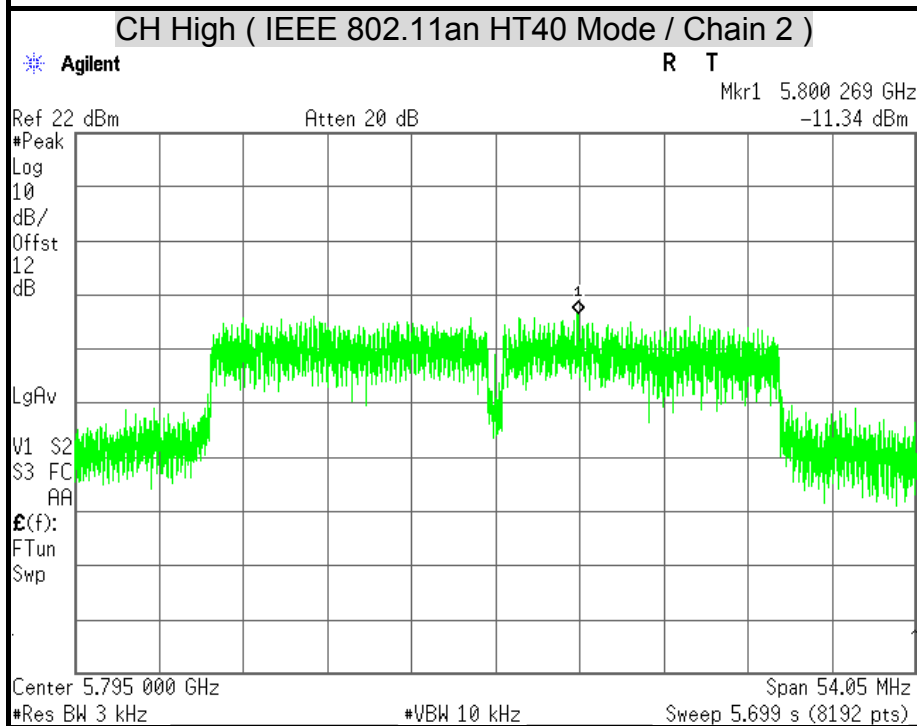
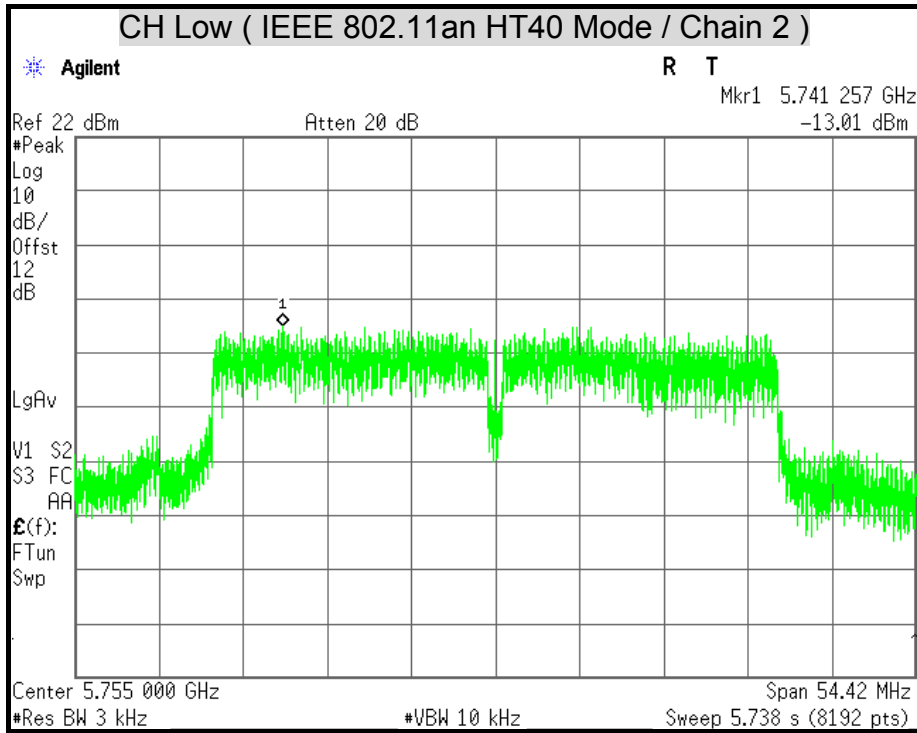

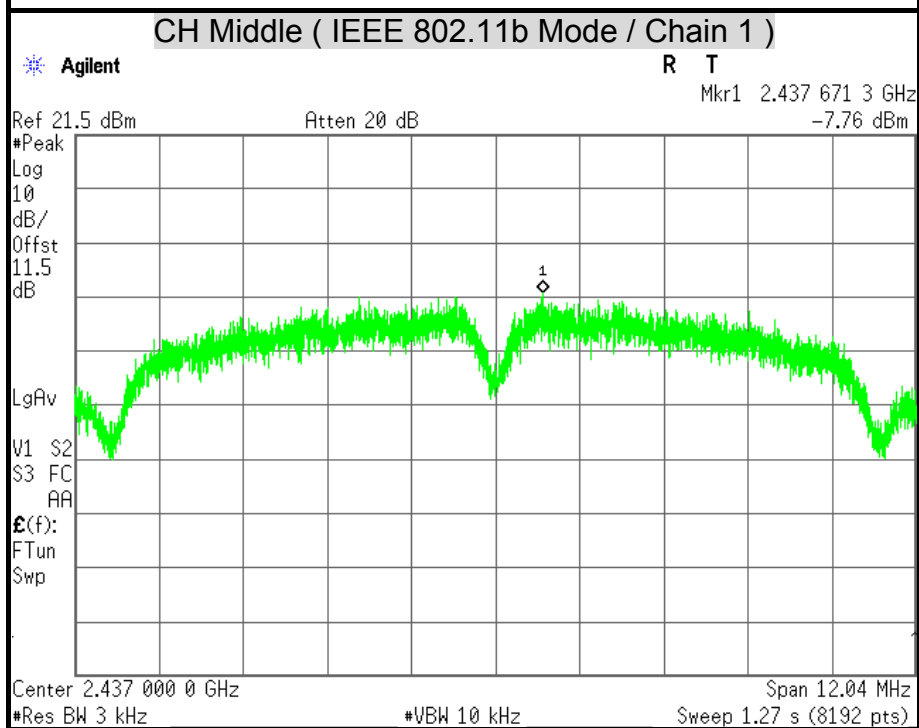
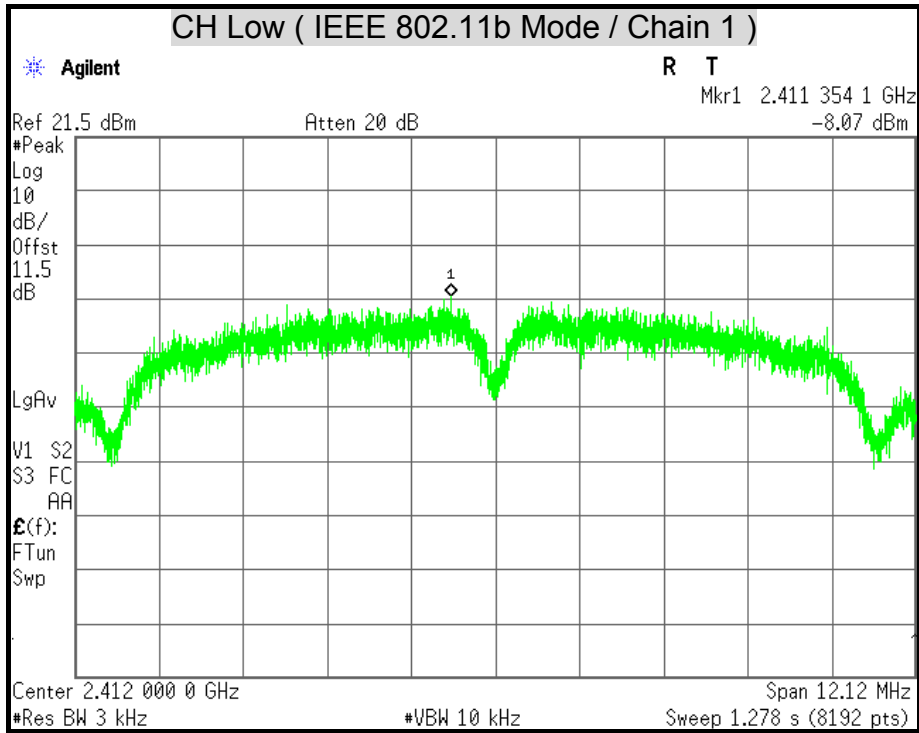

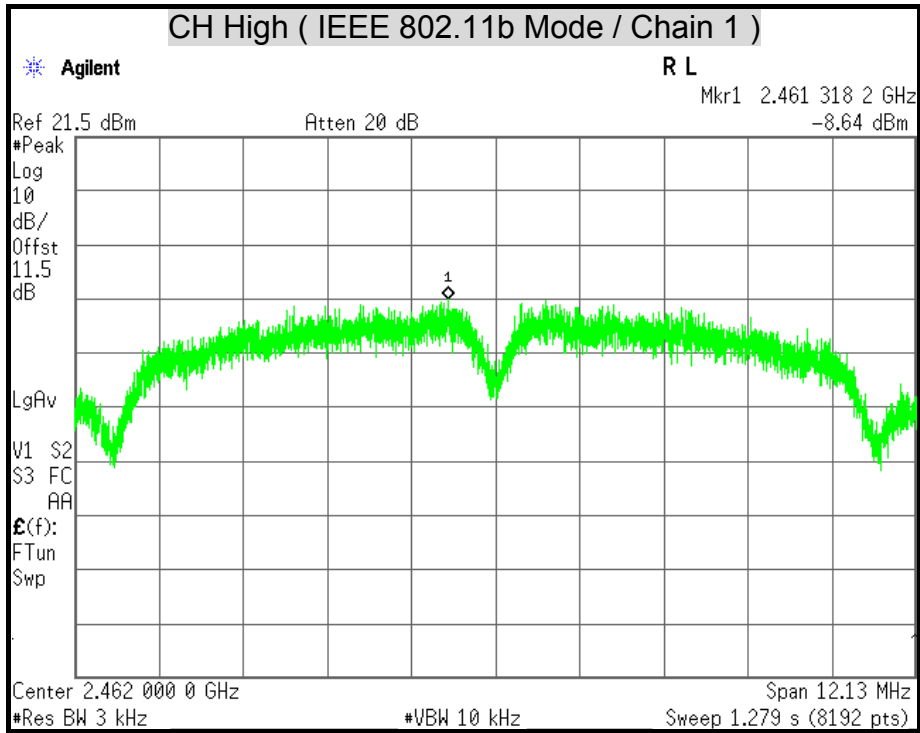

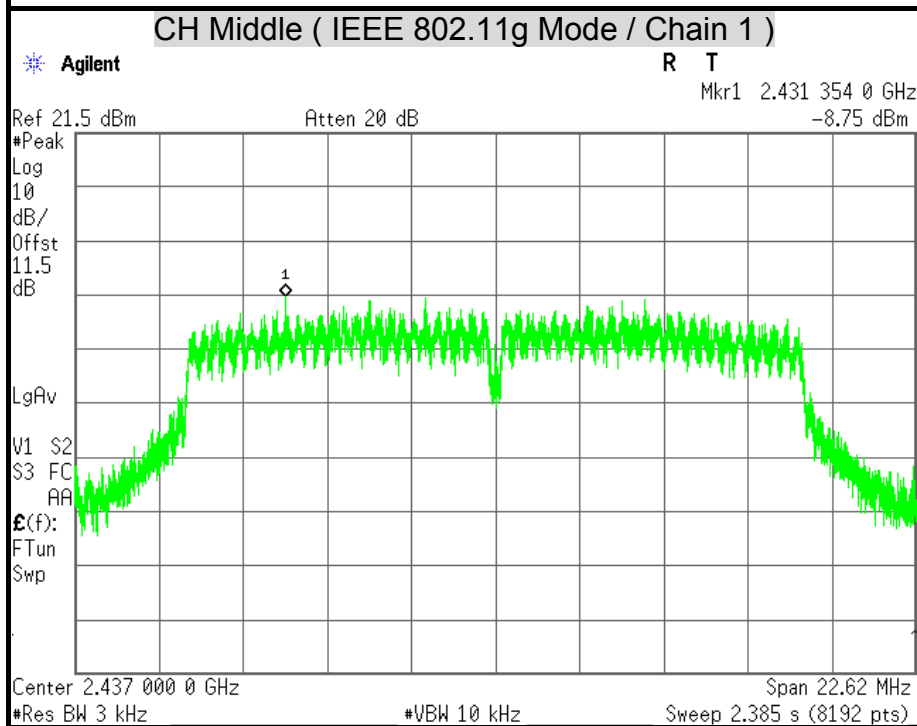
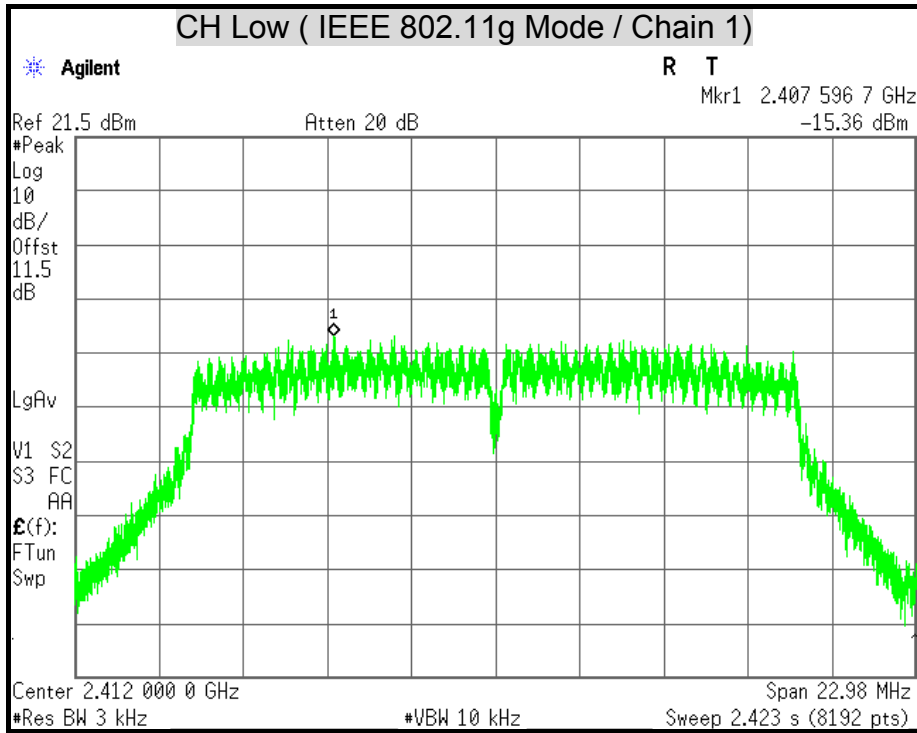

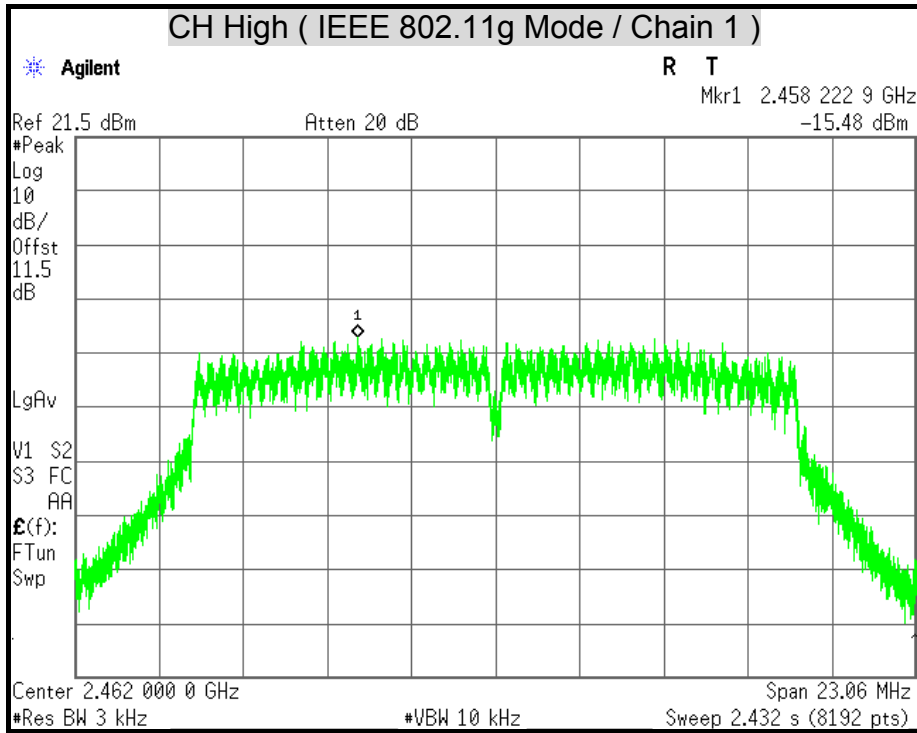

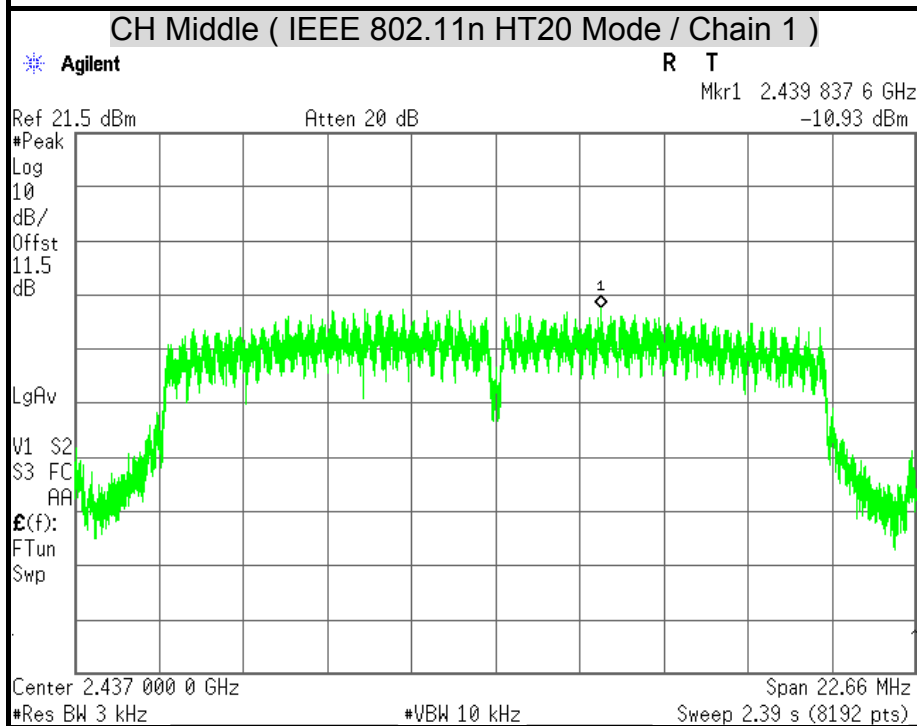
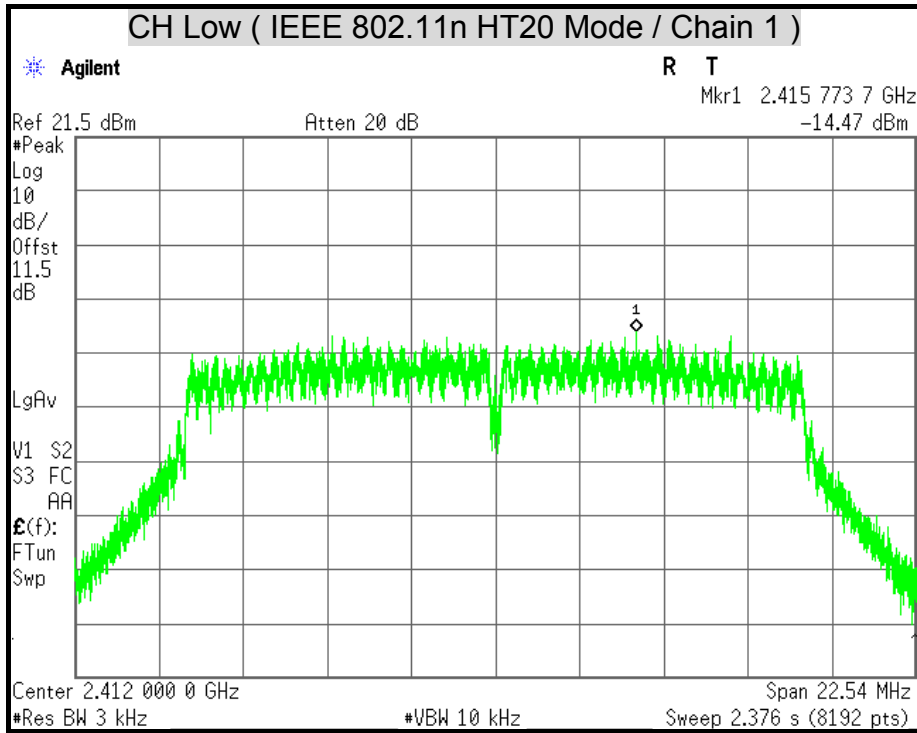

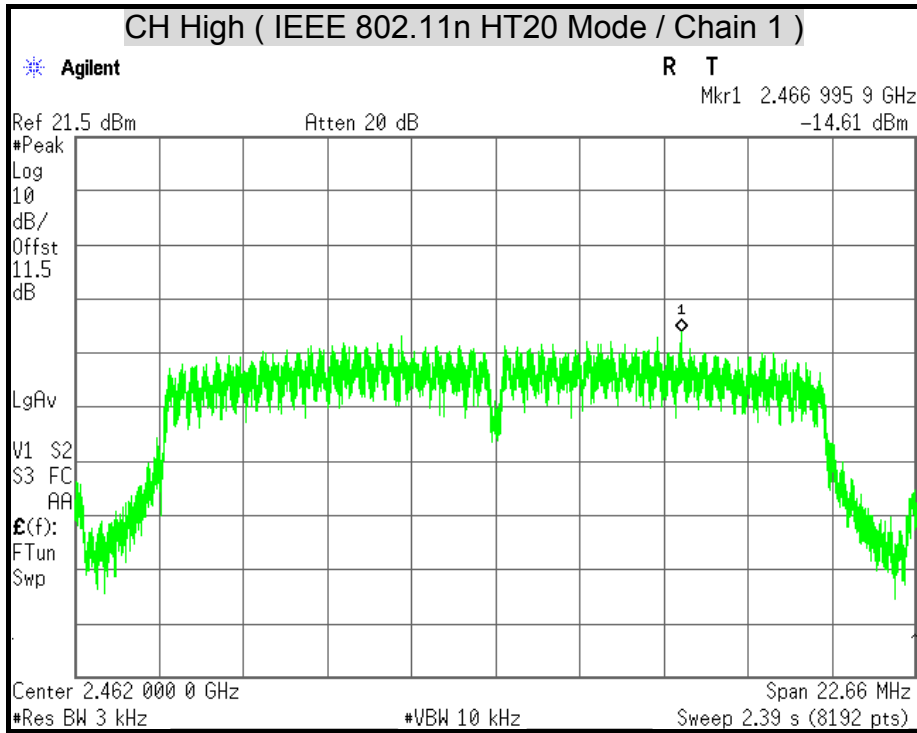

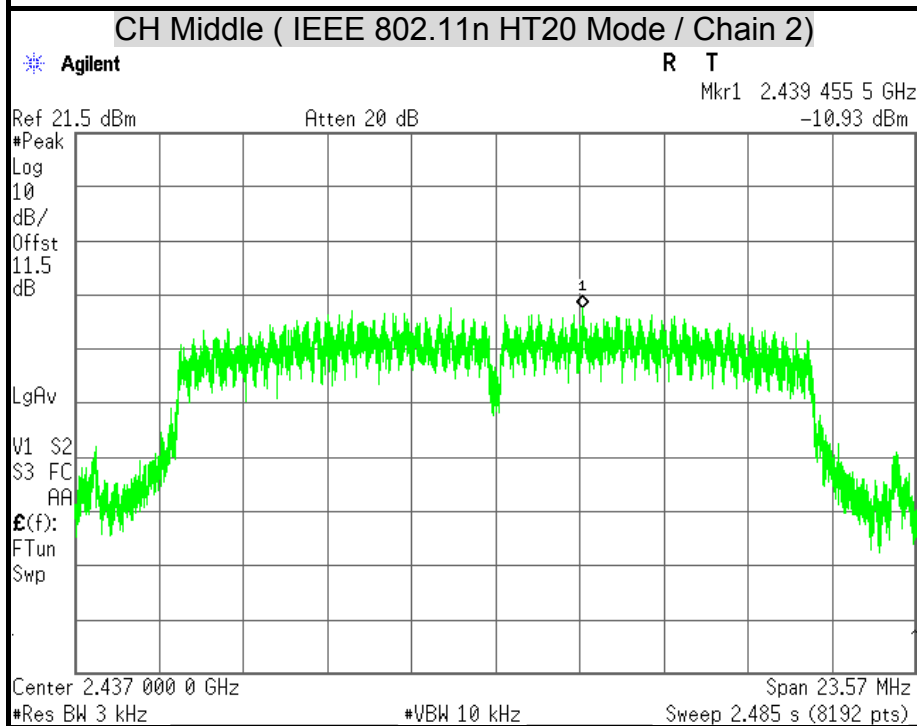
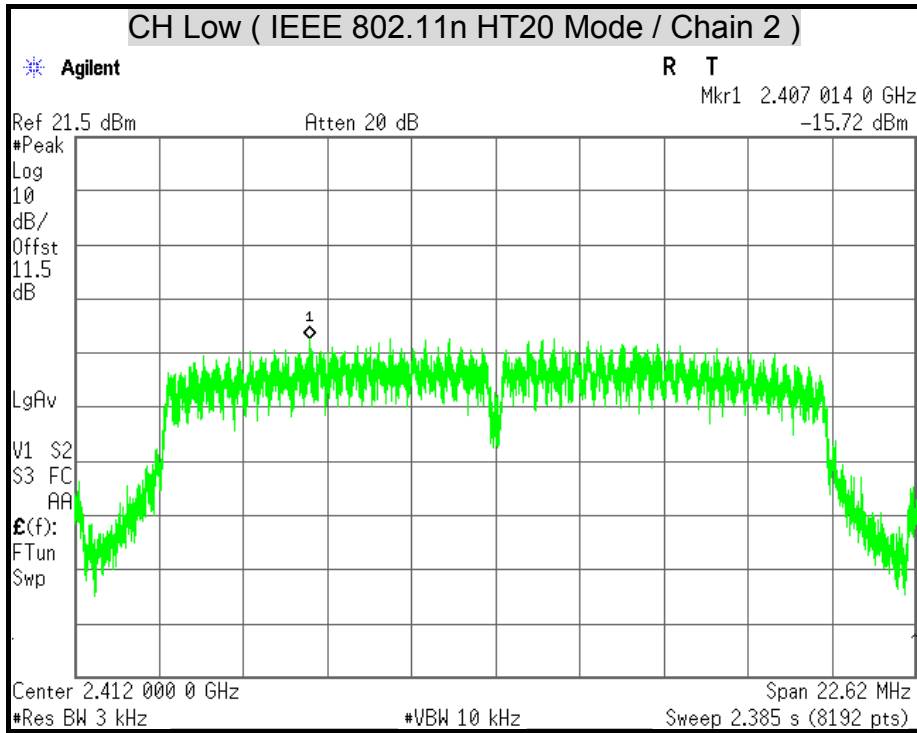

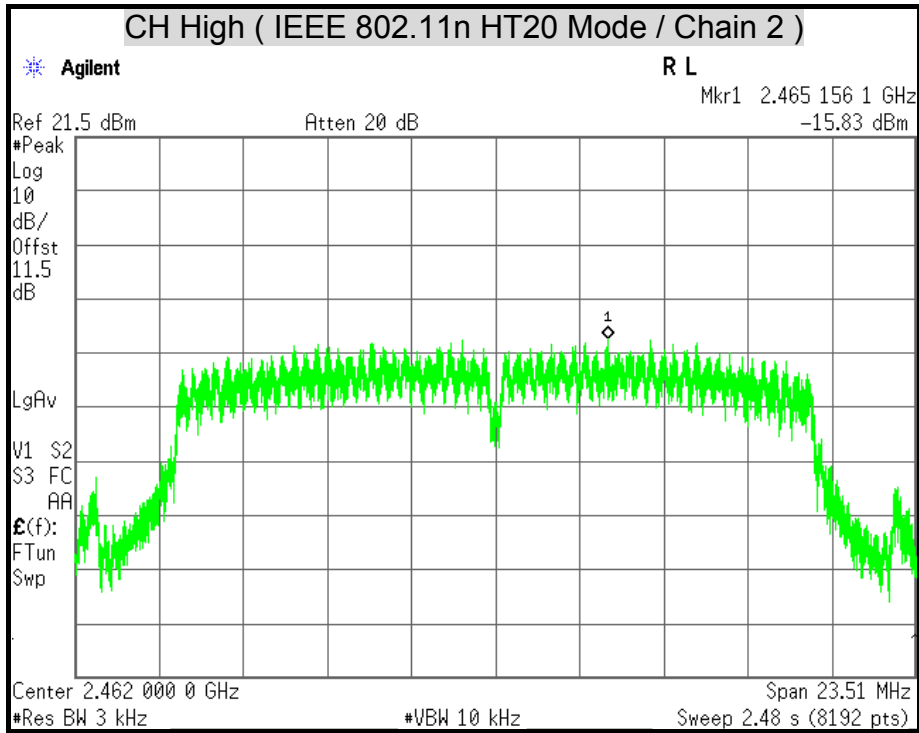

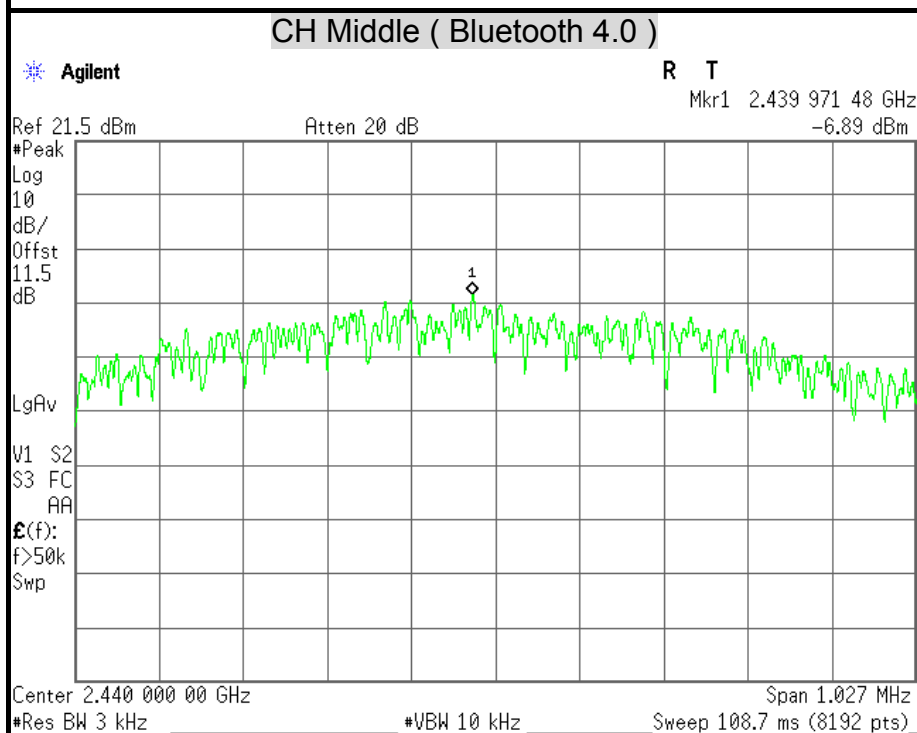
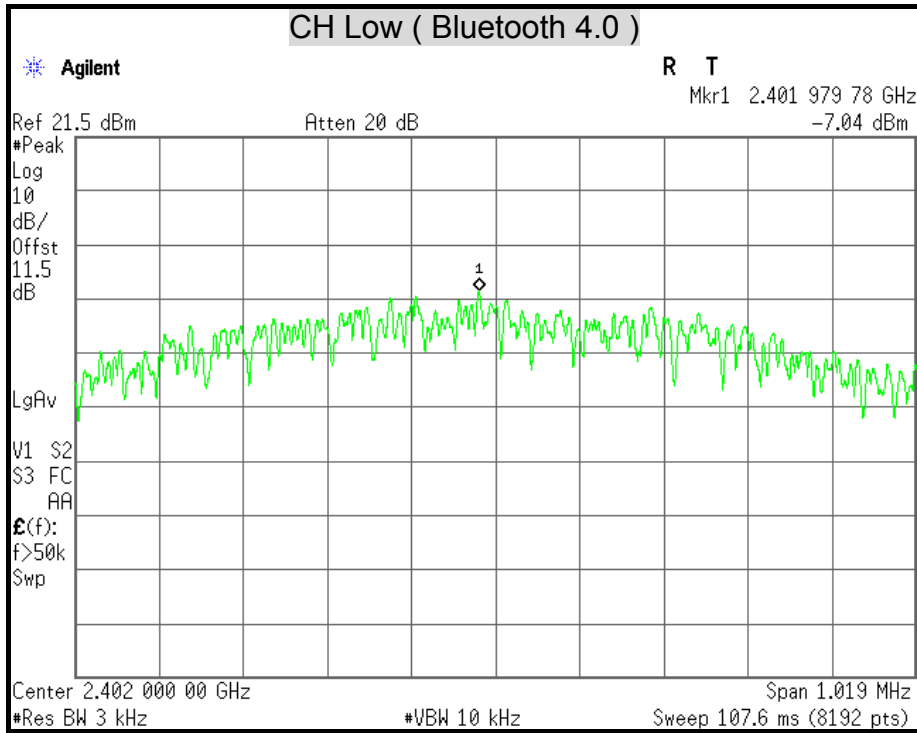

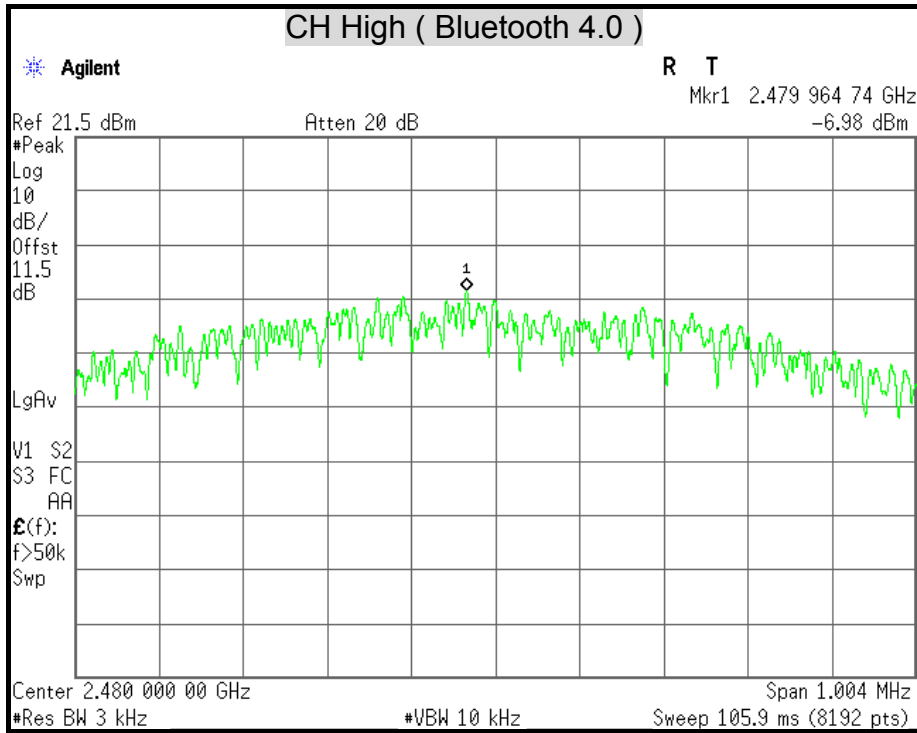



7.5 CONDUCTED SPURIOUS EMISSION

LIMITS

§ 15.247(d) In any 100 kHz bandwidth outside the frequency band in which the spread spectrum intentional radiator is operating, the radio frequency power that is produced by the intentional radiator shall be at least 20 dB below that in the 100 kHz bandwidth within the and that contains the highest level of the desired power, based on either an RF conducted or a radiated measurement. Attenuation below the general limits specified in § 15.209(a) is not required. In addition, radiated emissions which fall in the restricted bands, as defined in § 15.205(a), must also comply with the radiated emission limits specified in § 15.209(a) (see § 15.205(c)).

TEST EQUIPMENT

Name of Equipment	Manufacturer	Model	Serial Number	Calibration Due
Spectrum Analyzer	Agilent	E4446A	MY43360132	06/10/2014

Remark: Each piece of equipment is scheduled for calibration once a year.

TEST SETUP

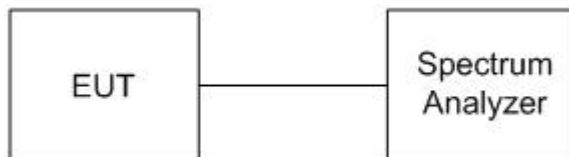

TEST PROCEDURE

The transmitter output is connected to a spectrum analyzer. The resolution bandwidth is set to 100 kHz. The video bandwidth is set to 300 kHz.

The spectrum from 30 MHz to 26.5 GHz is investigated with the transmitter set to the lowest, middle, and highest channels in the 2.4 GHz band.



TEST RESULTS

OUT-OF-BAND SPURIOUS EMISSIONS-CONDUCTED MEASUREMENT

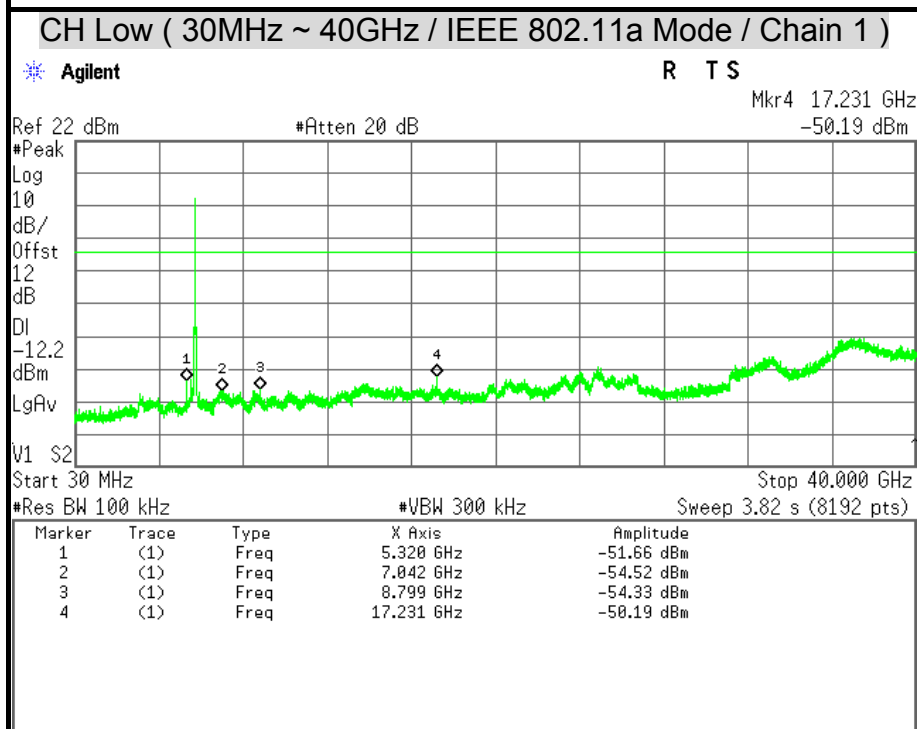
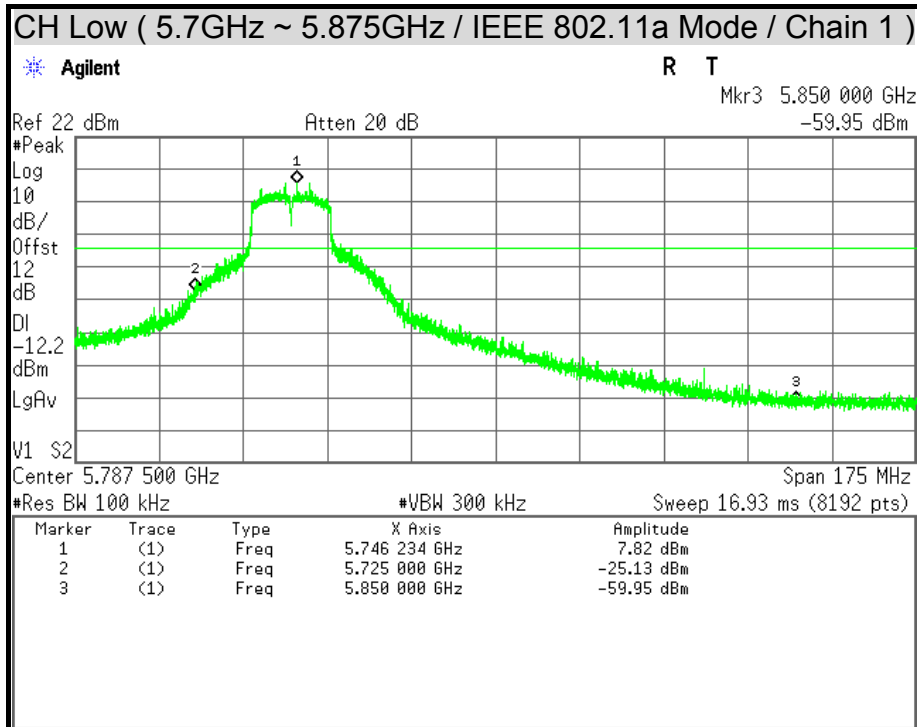

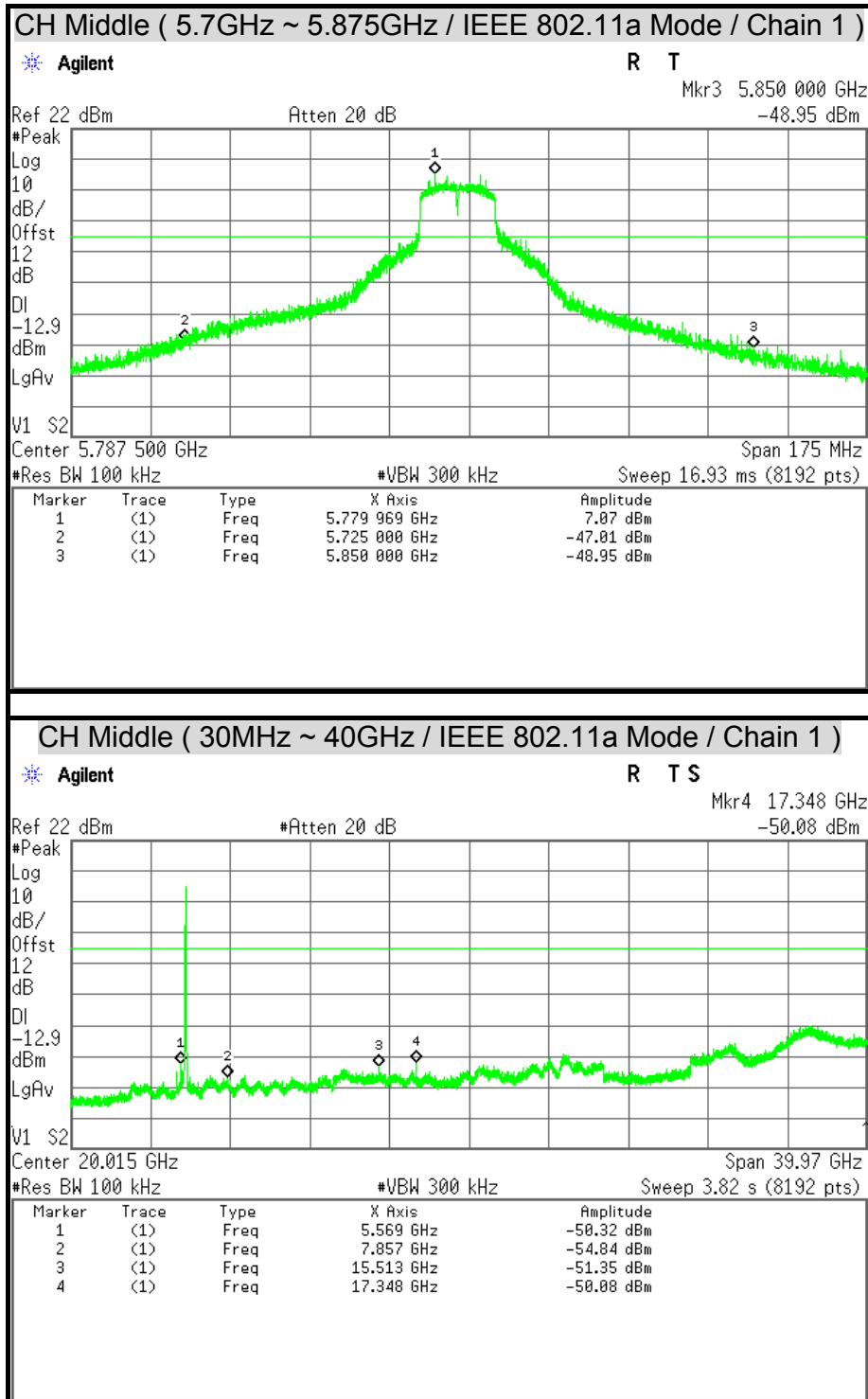

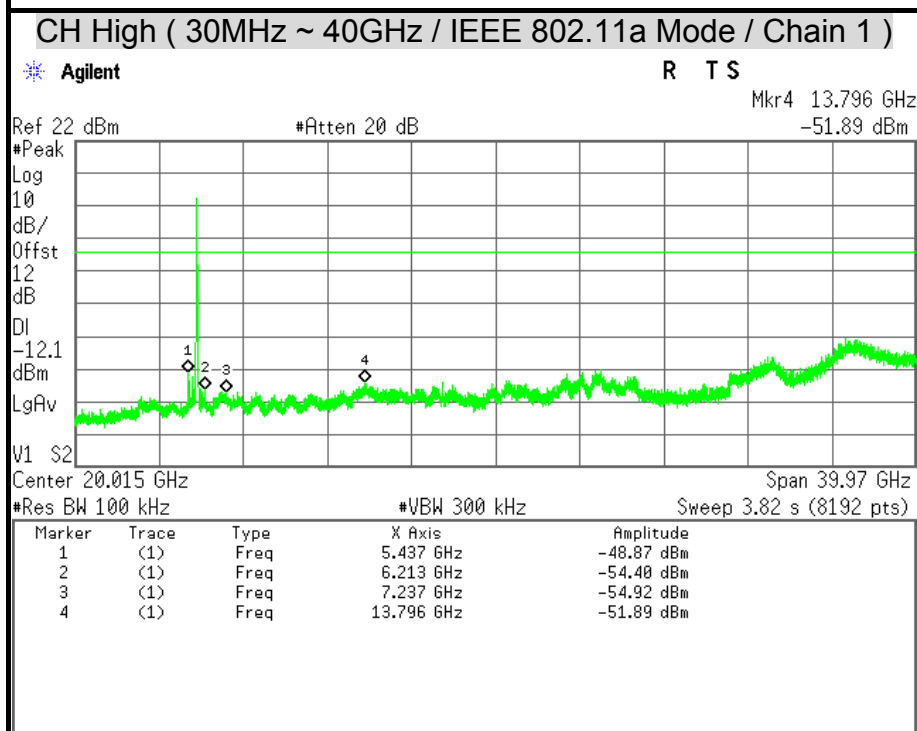
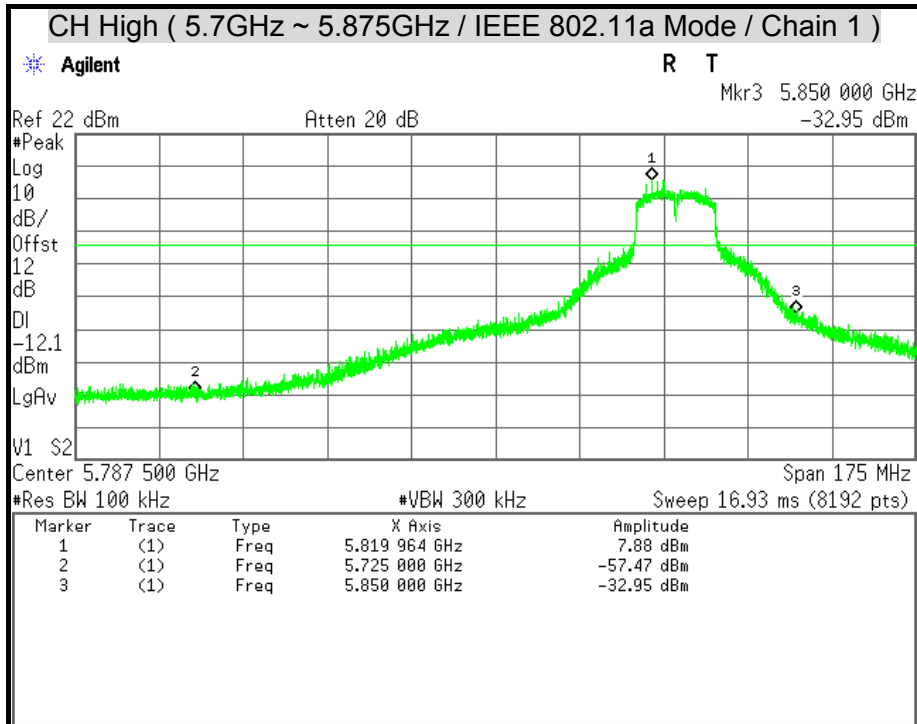

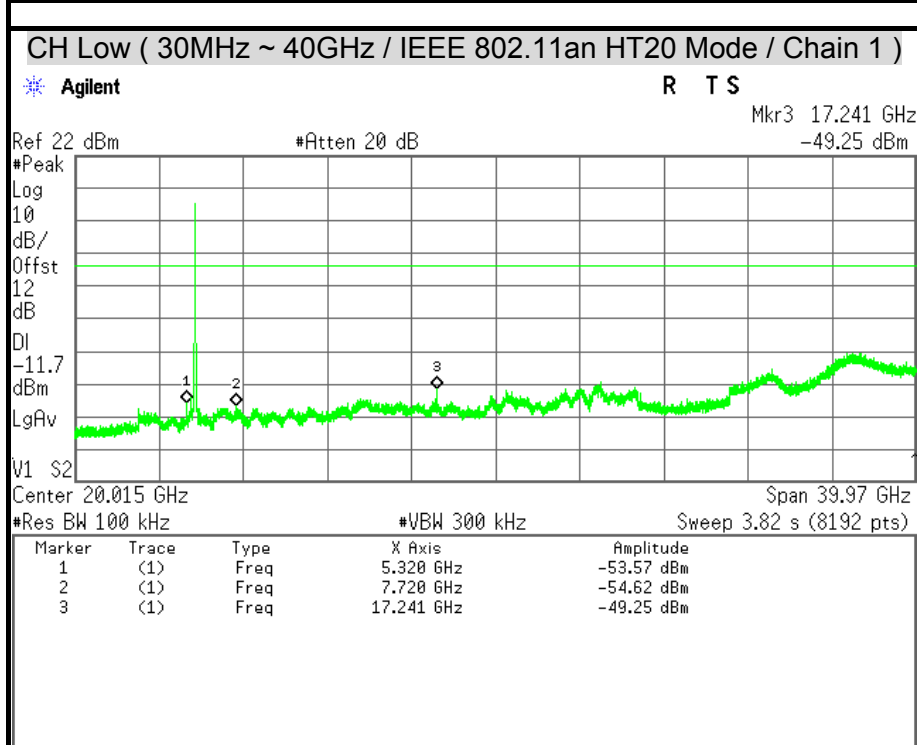
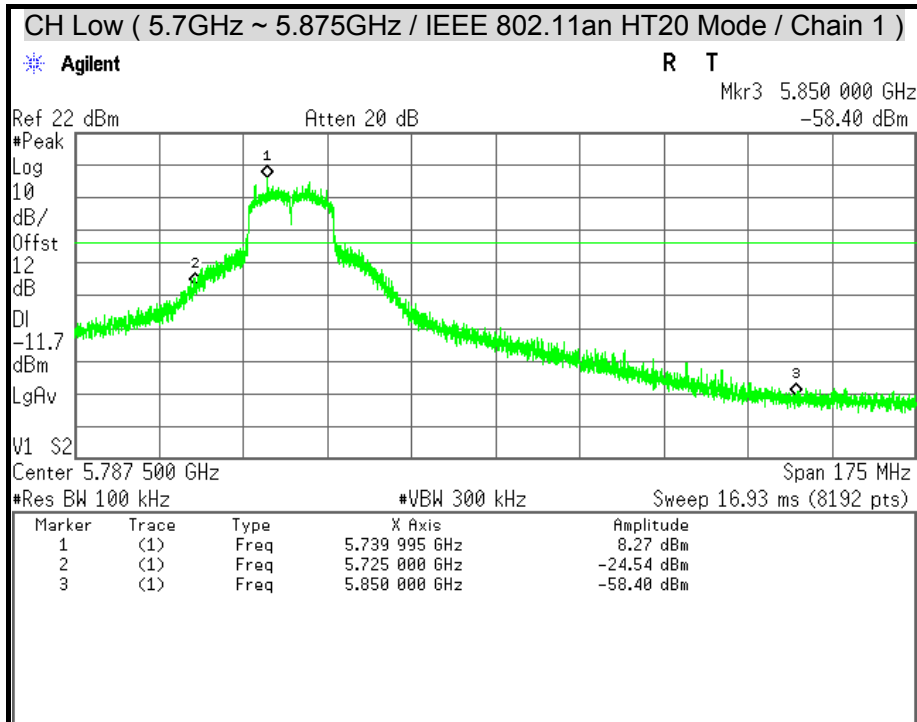

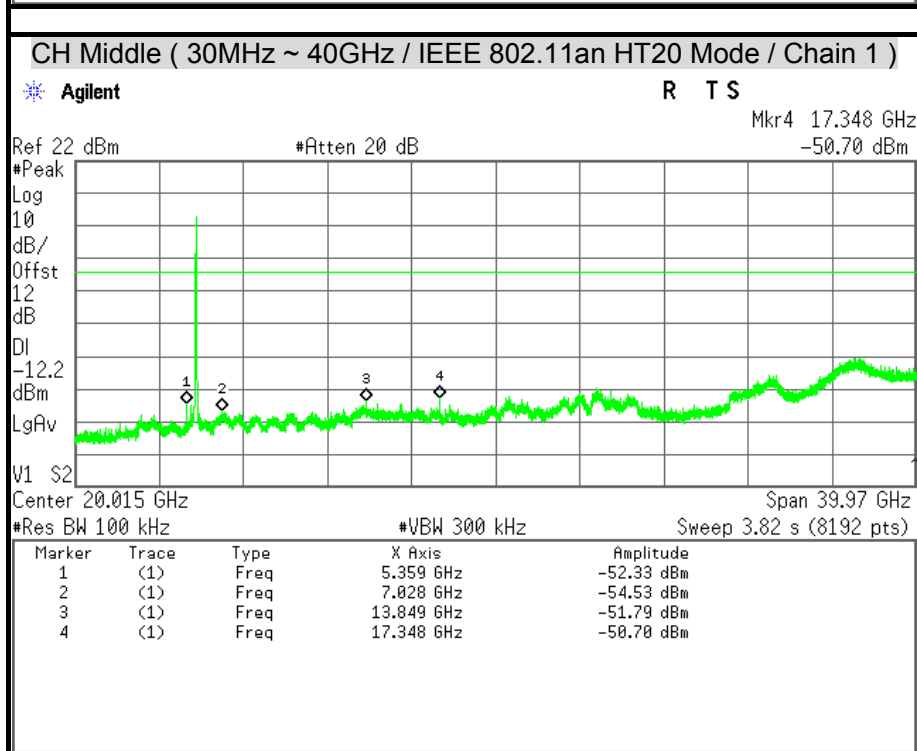
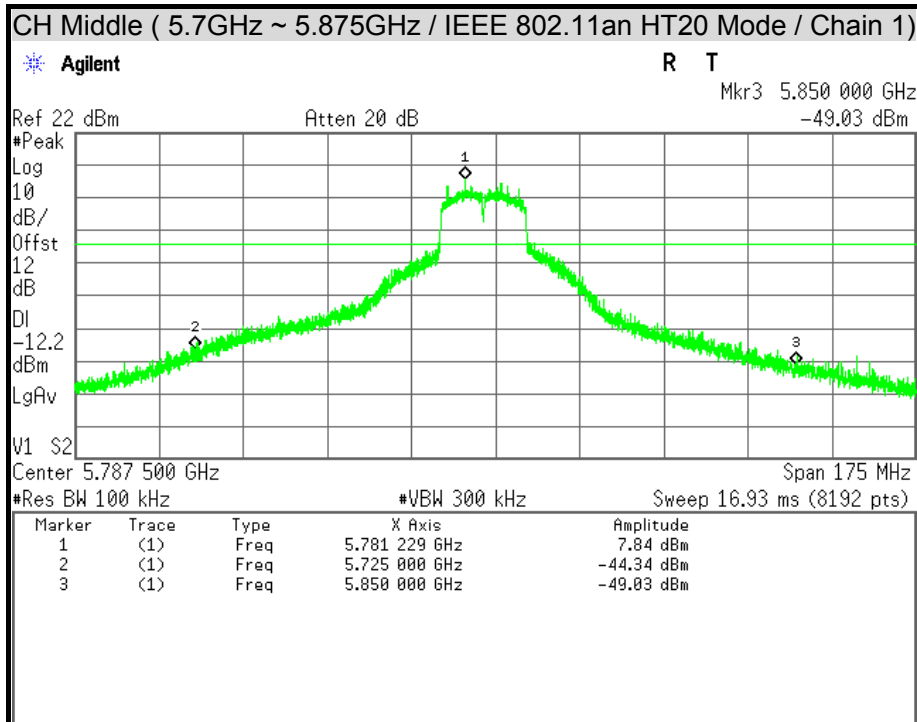

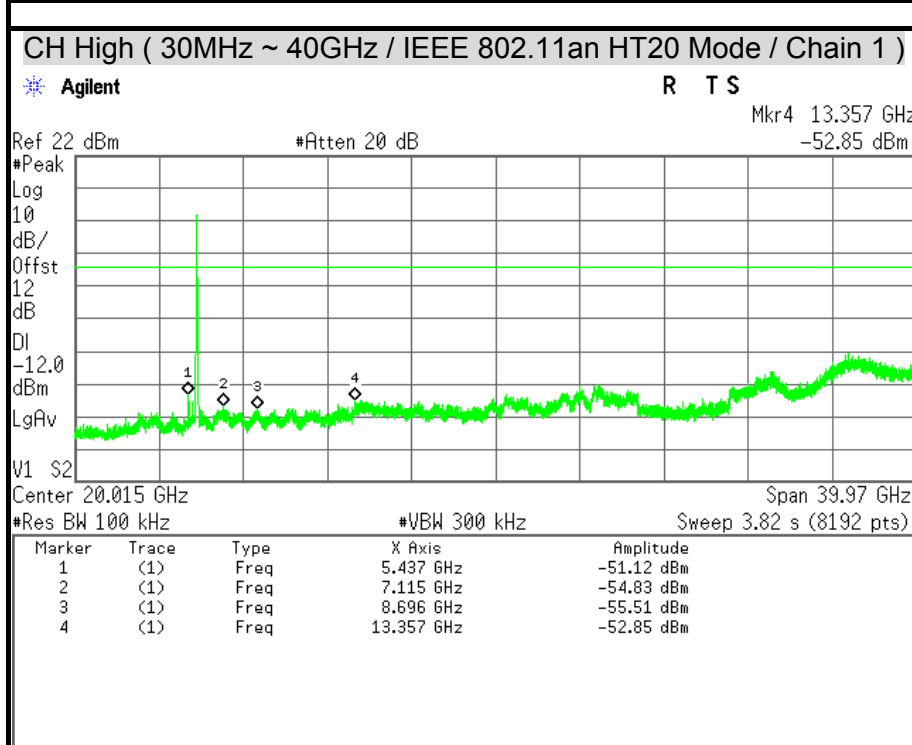
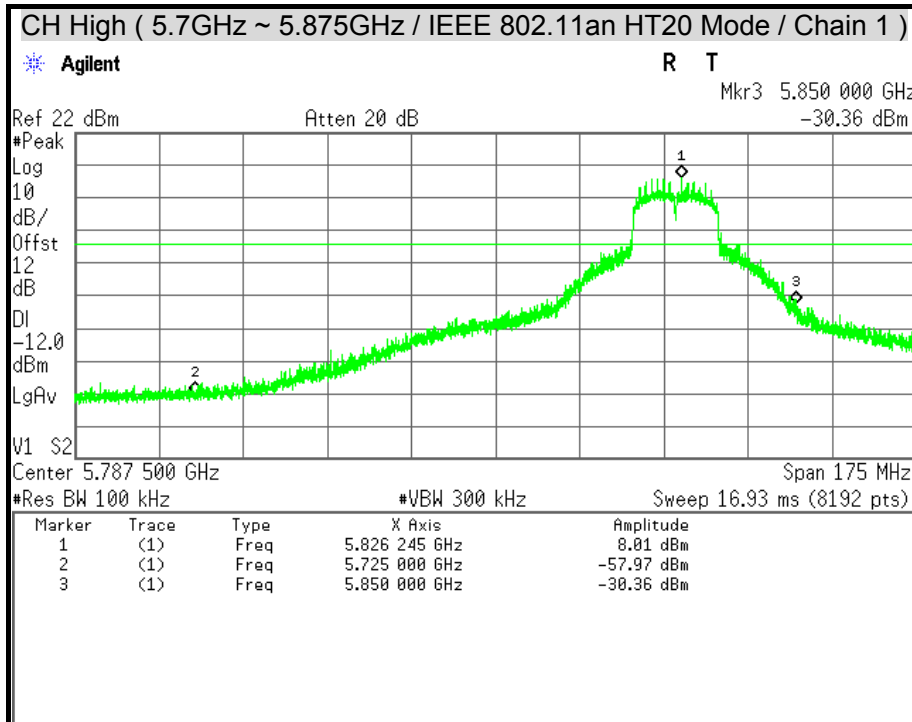

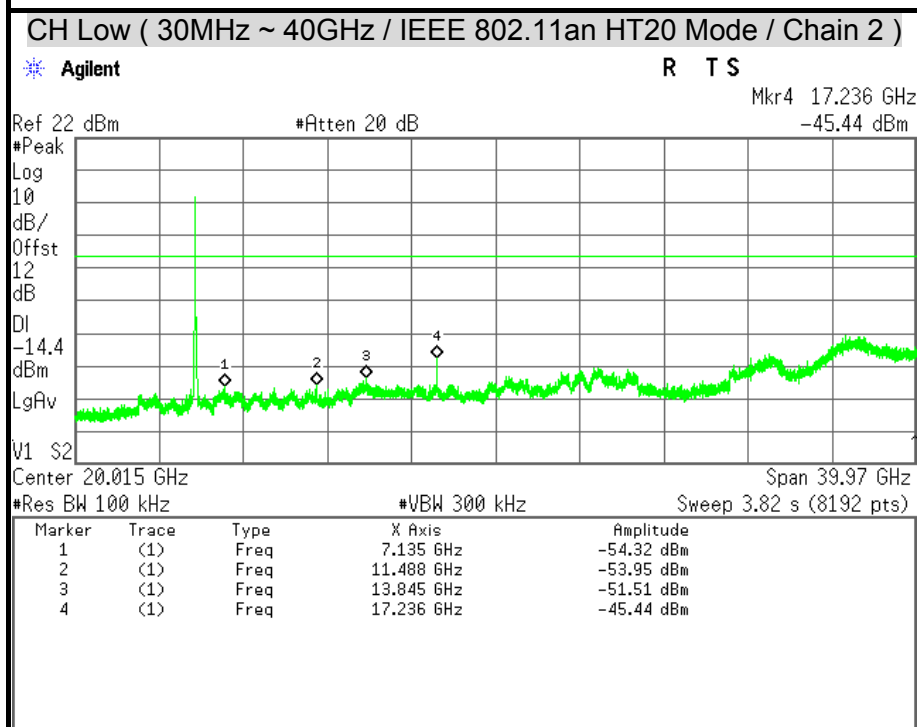
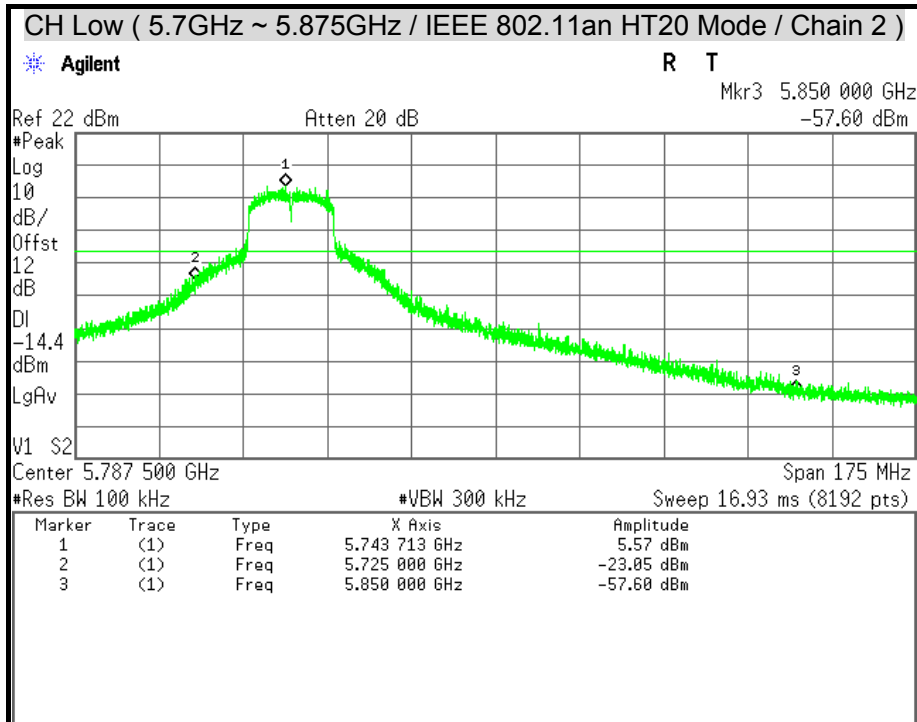

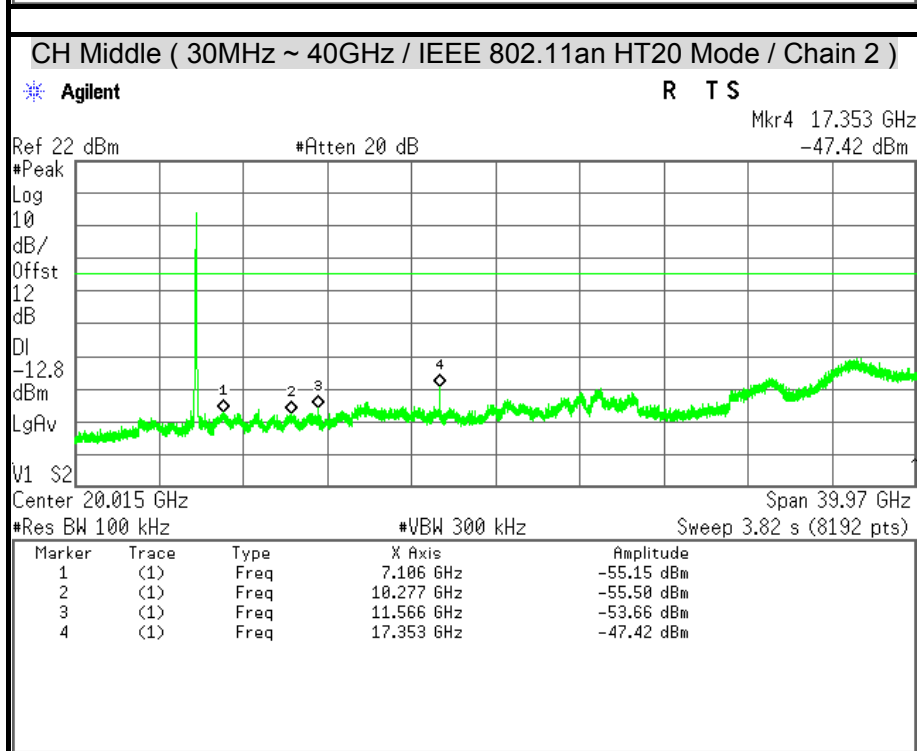
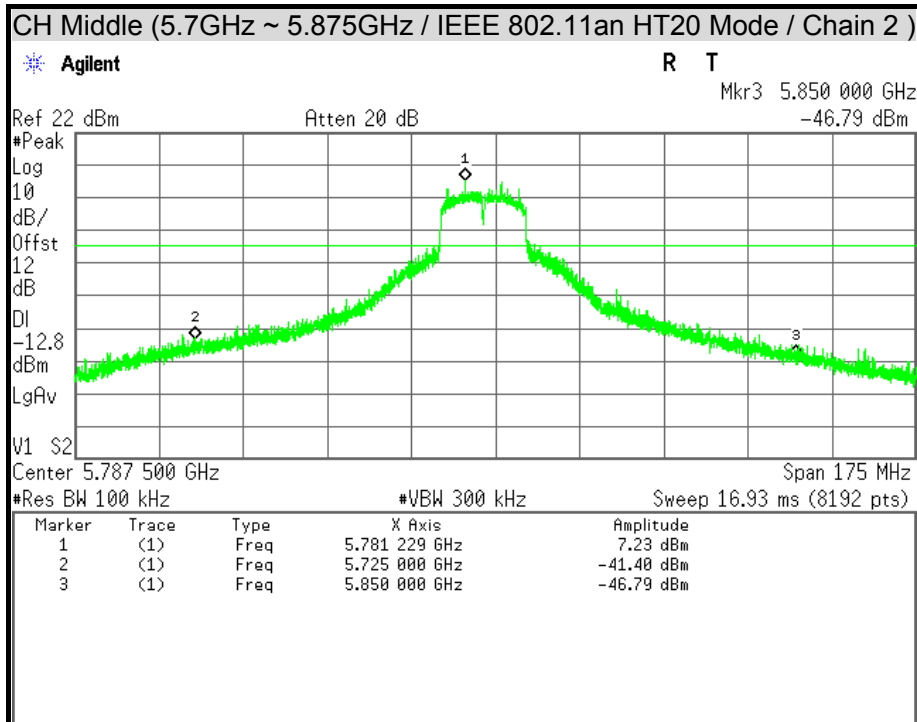

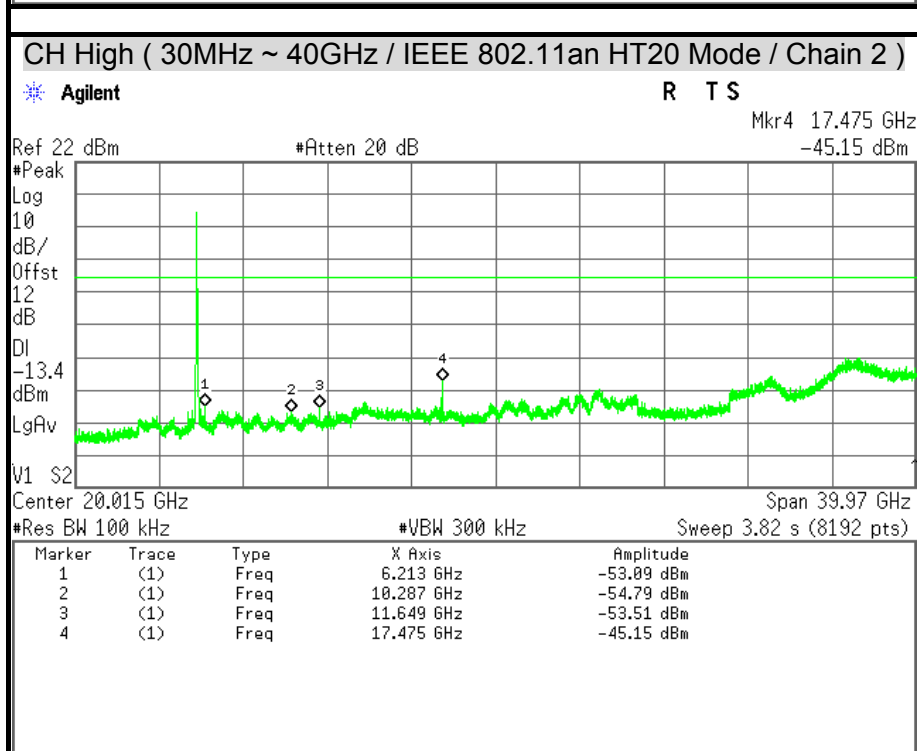
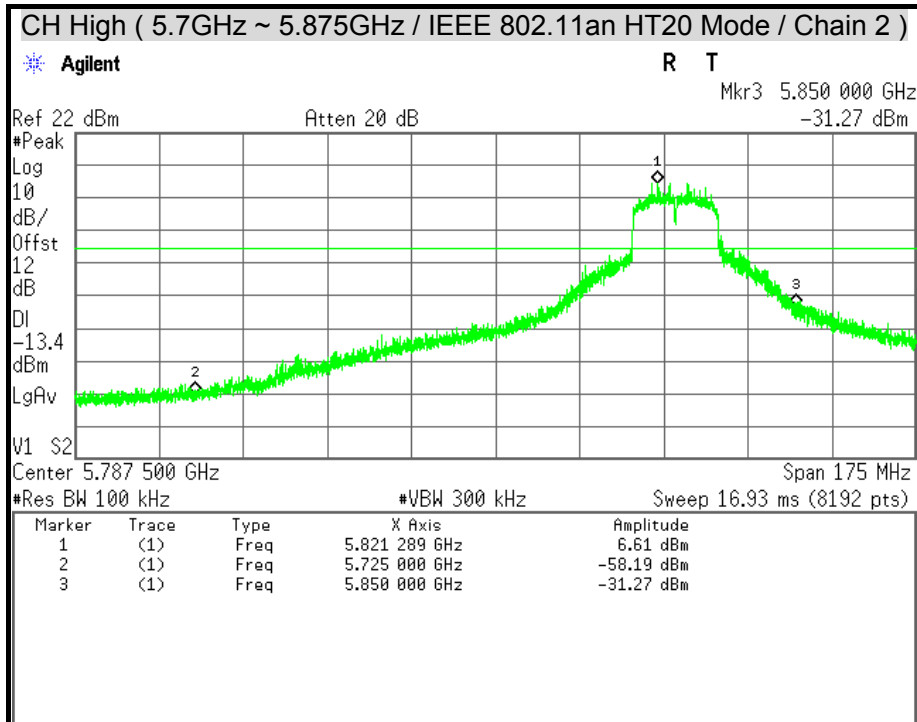

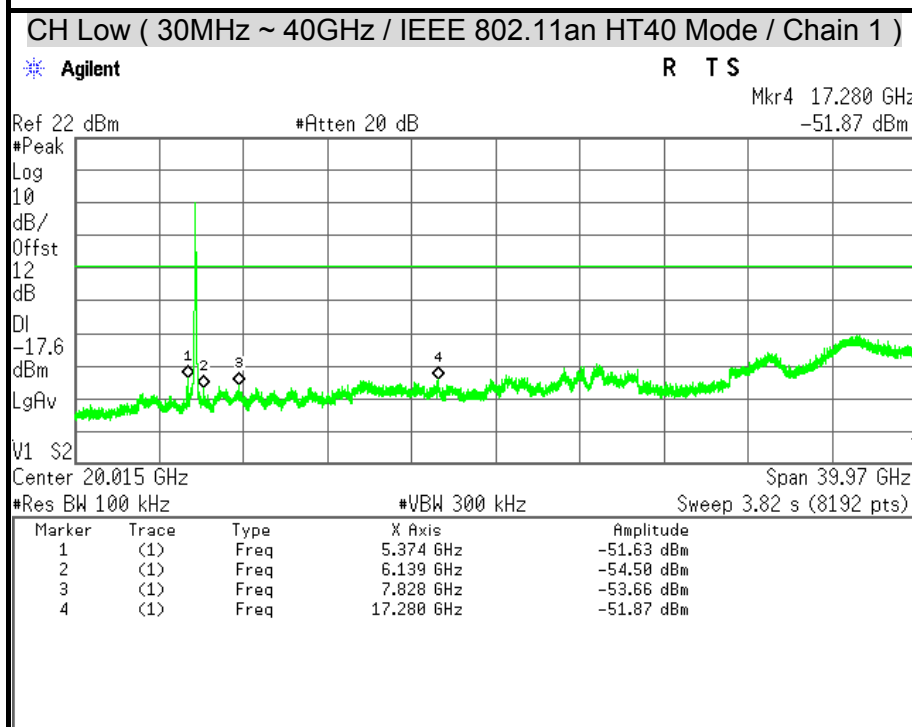
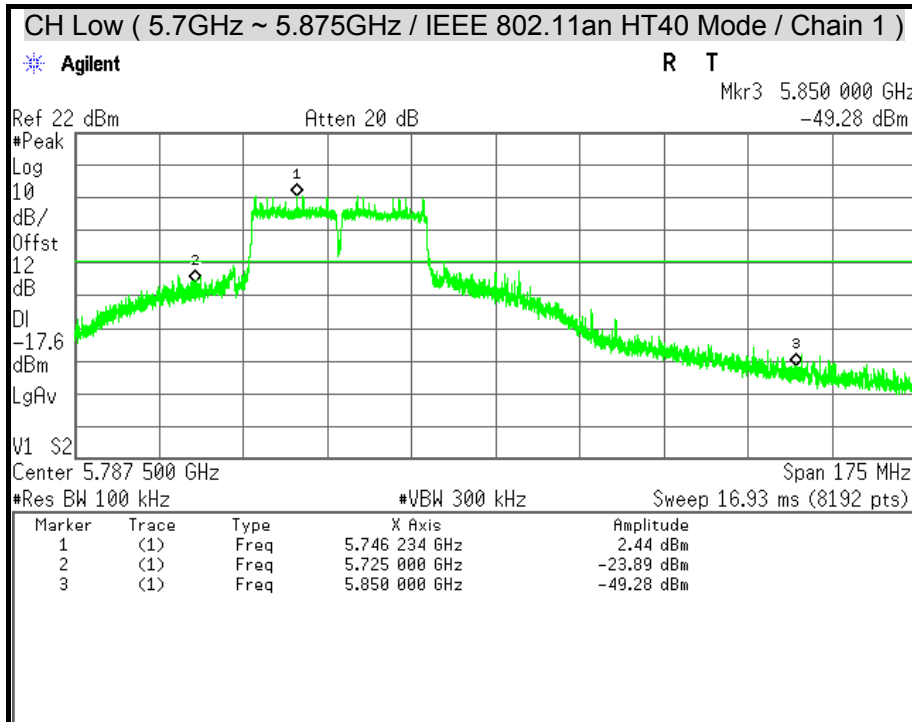

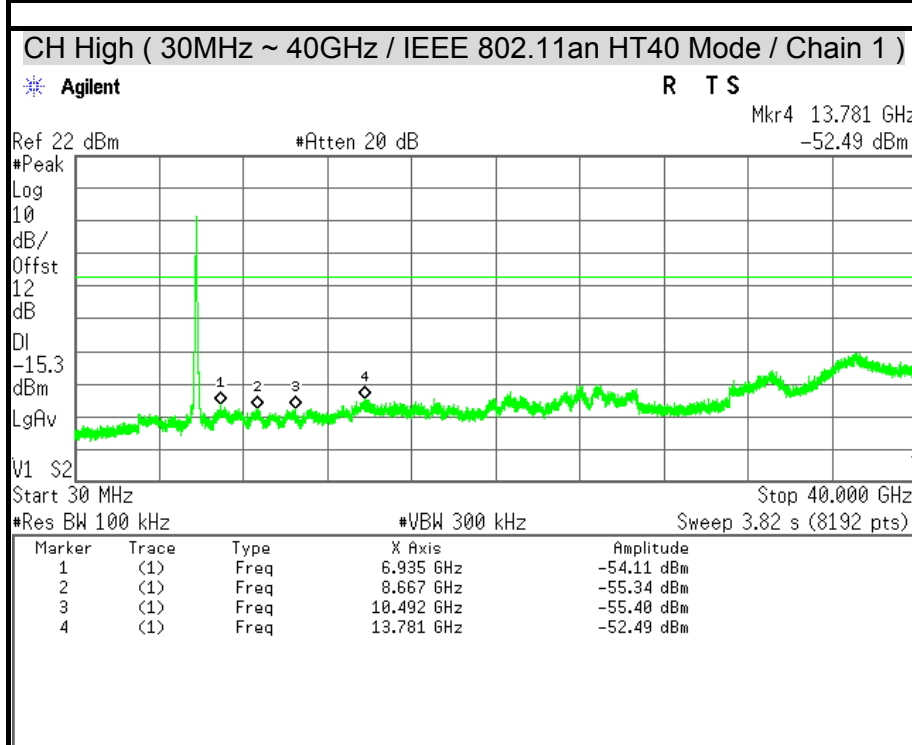
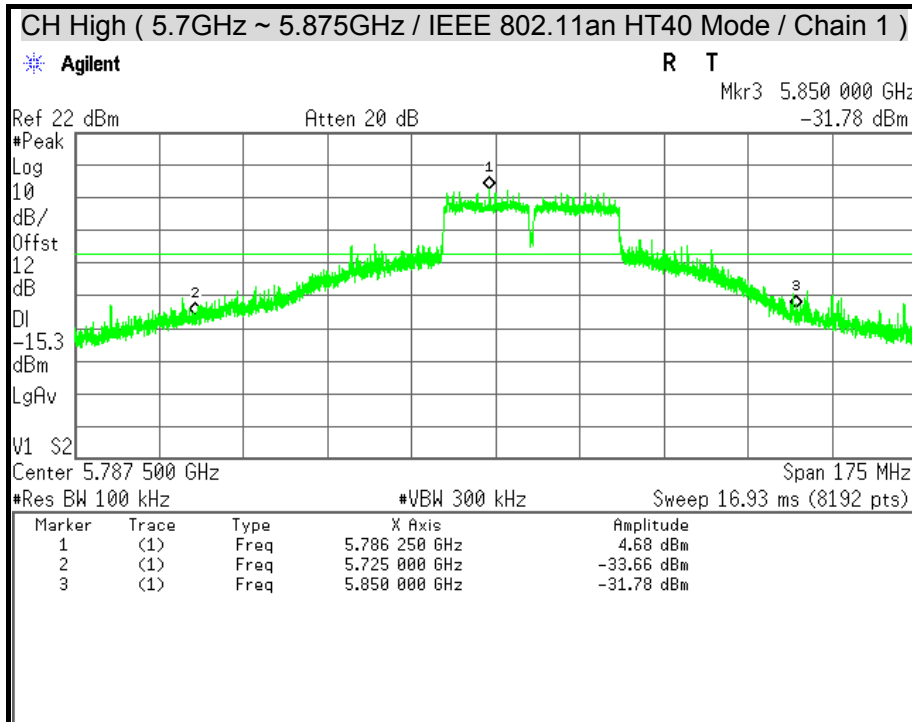

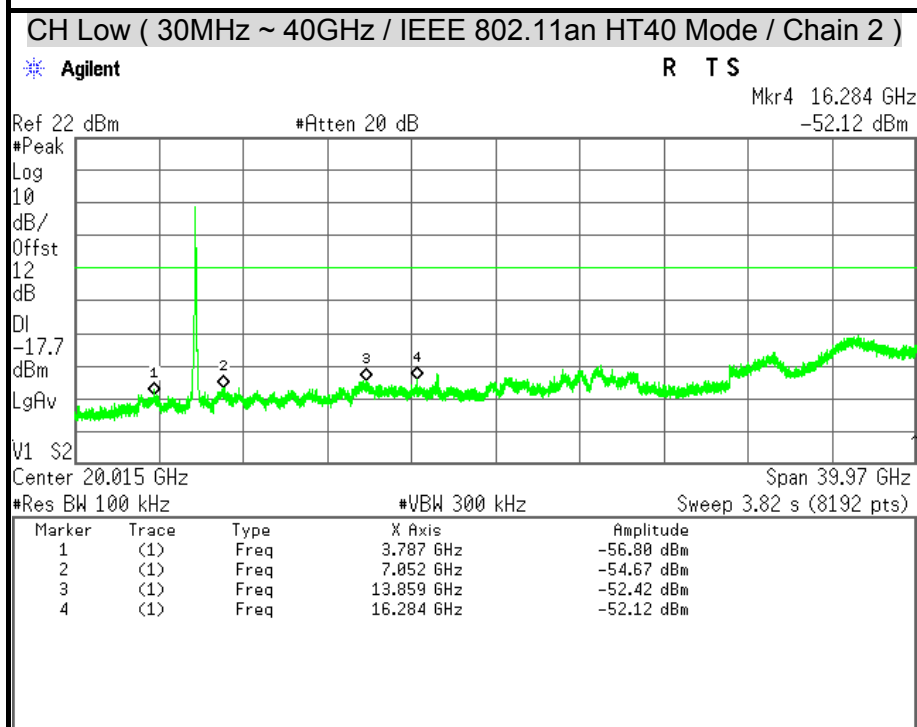
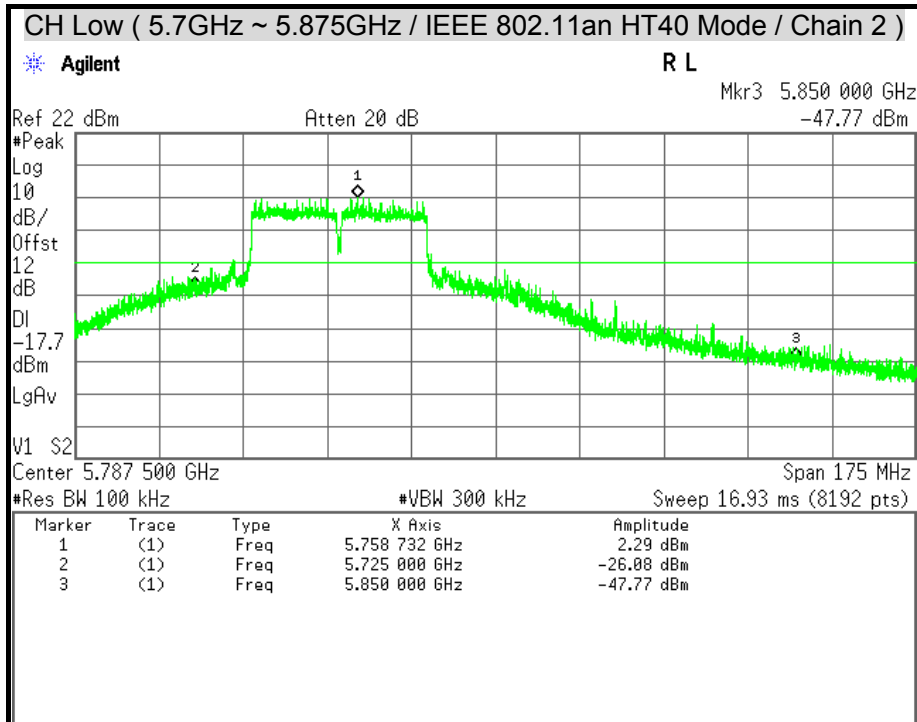

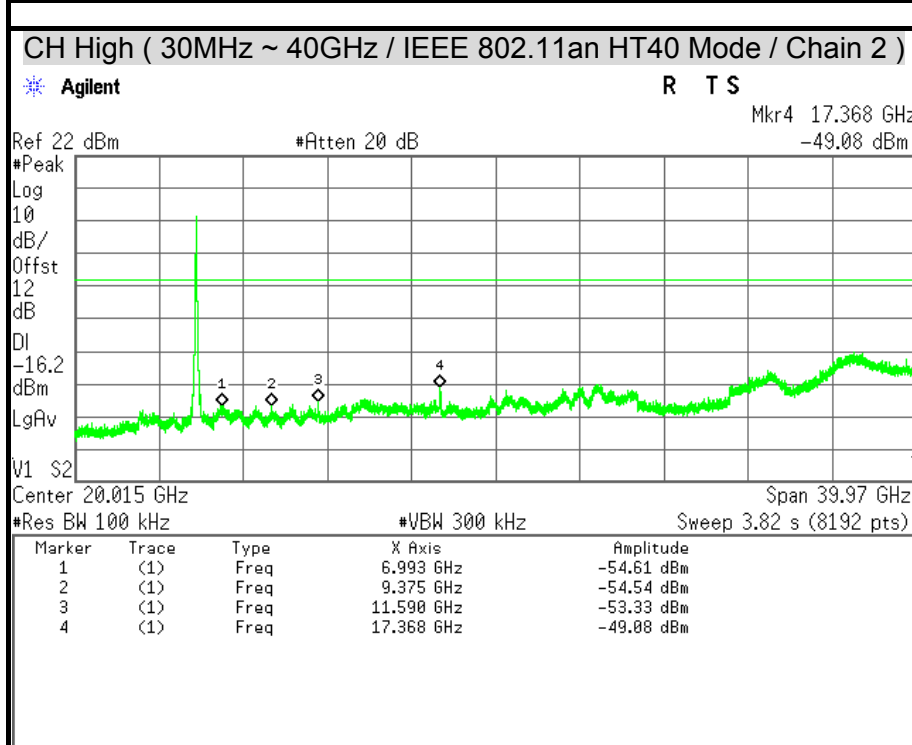
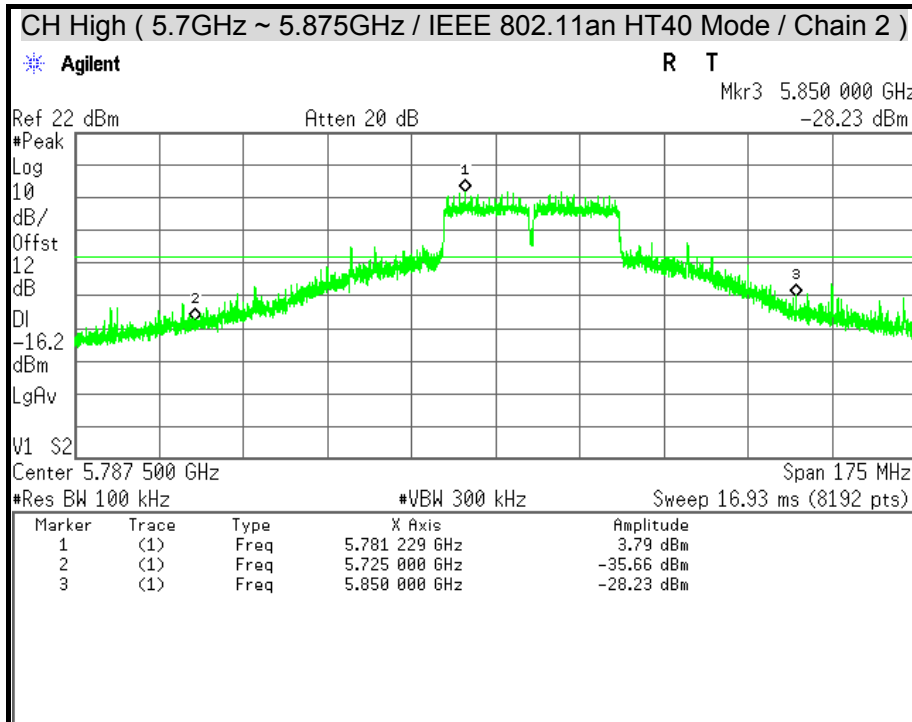

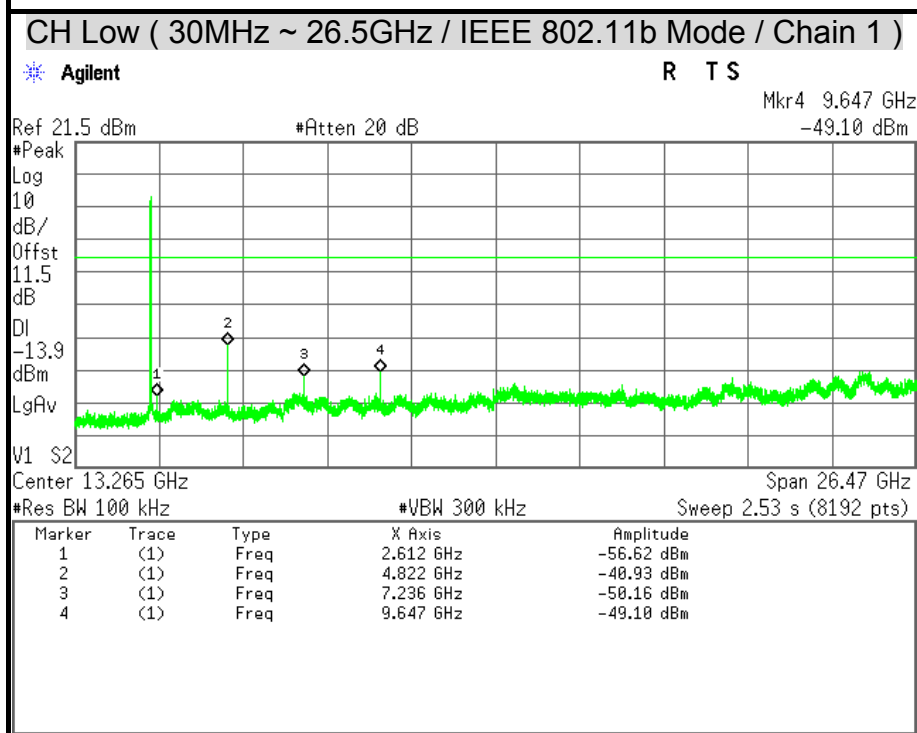
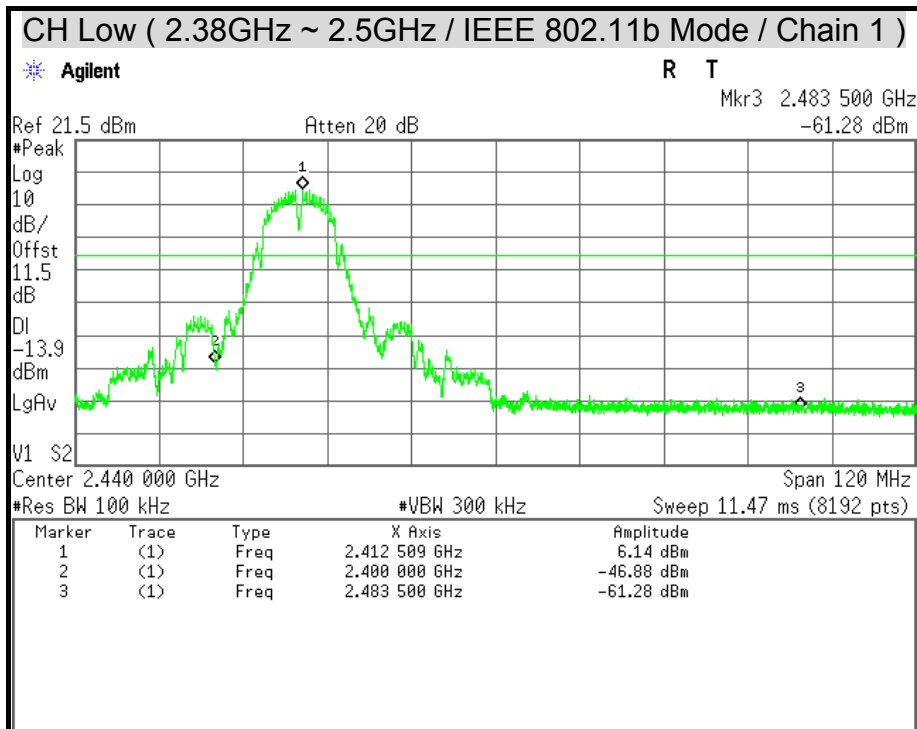

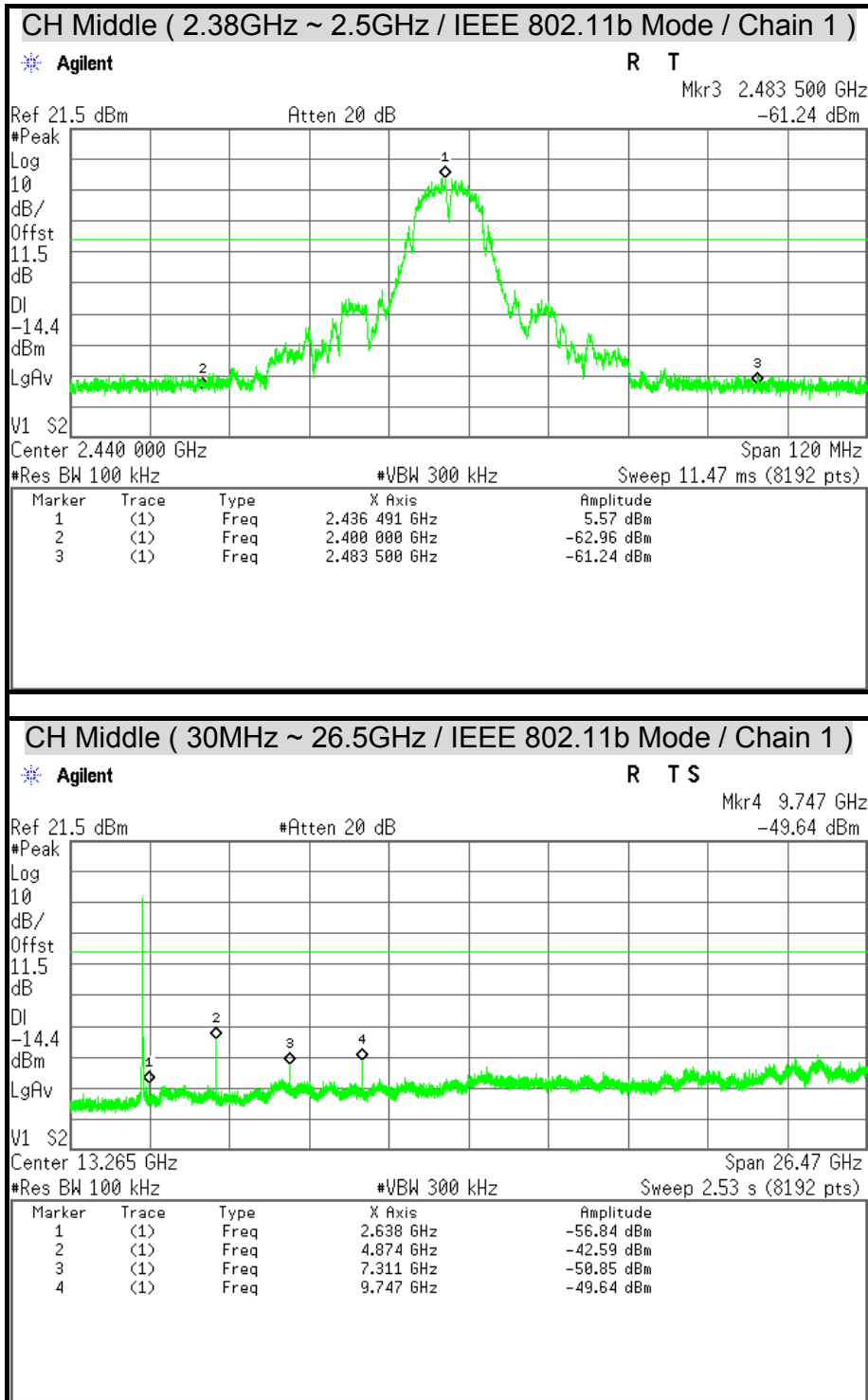

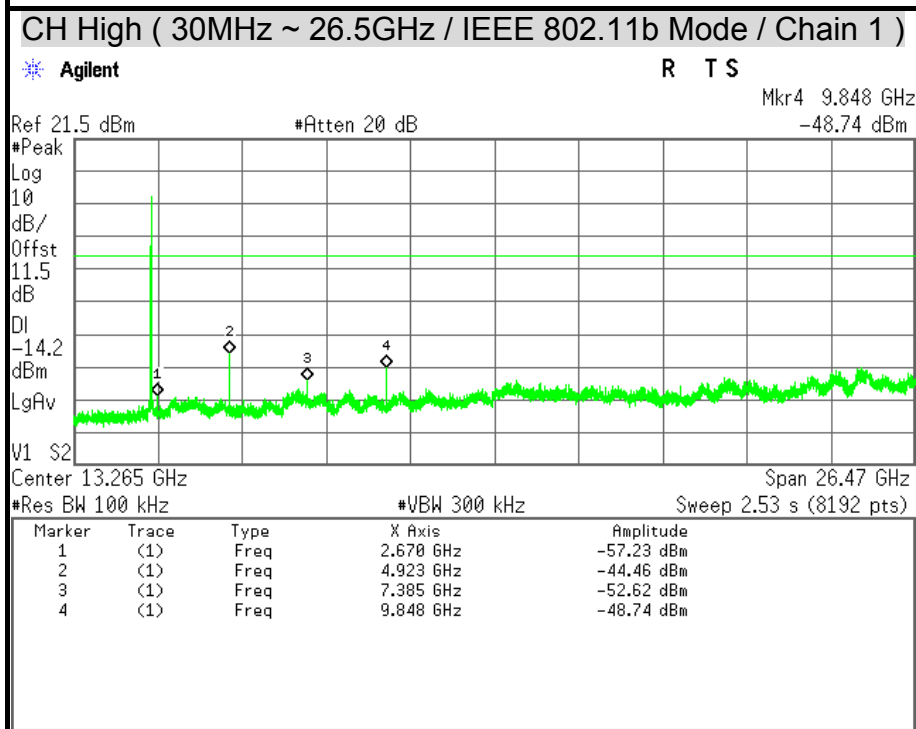
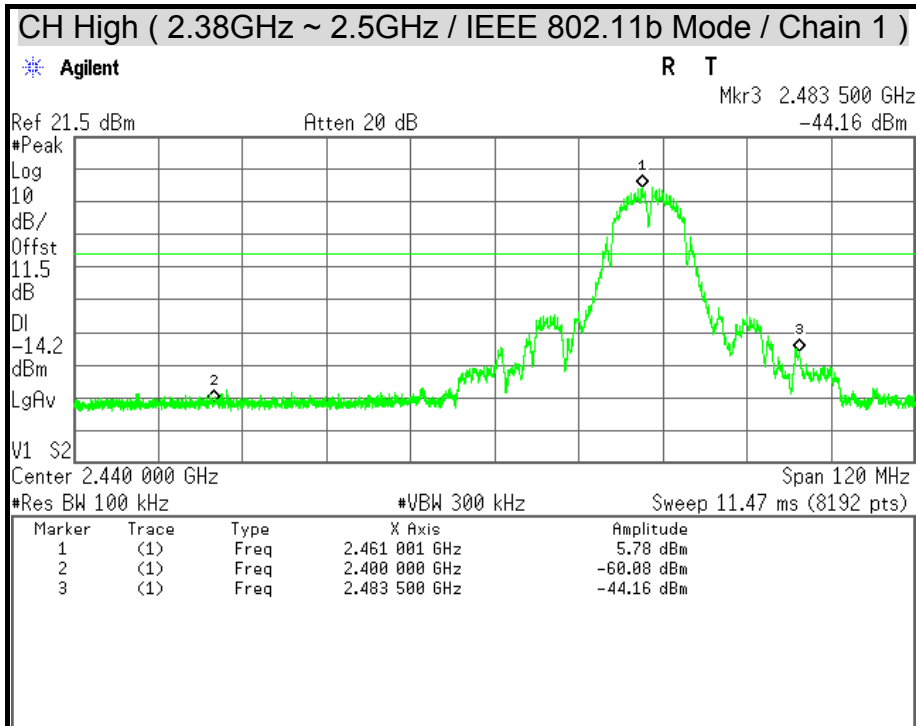

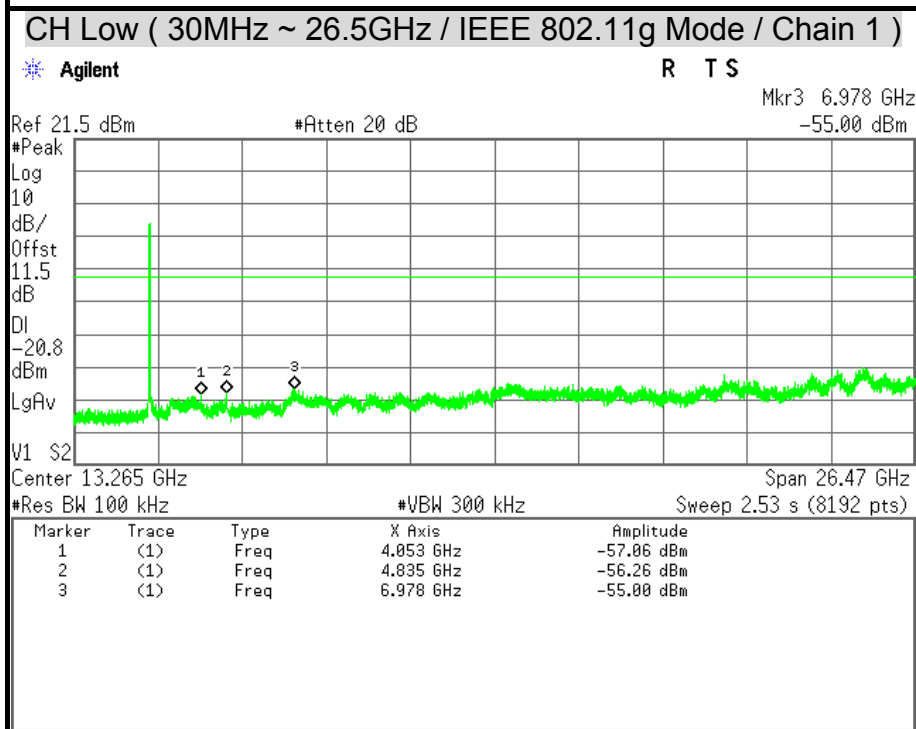
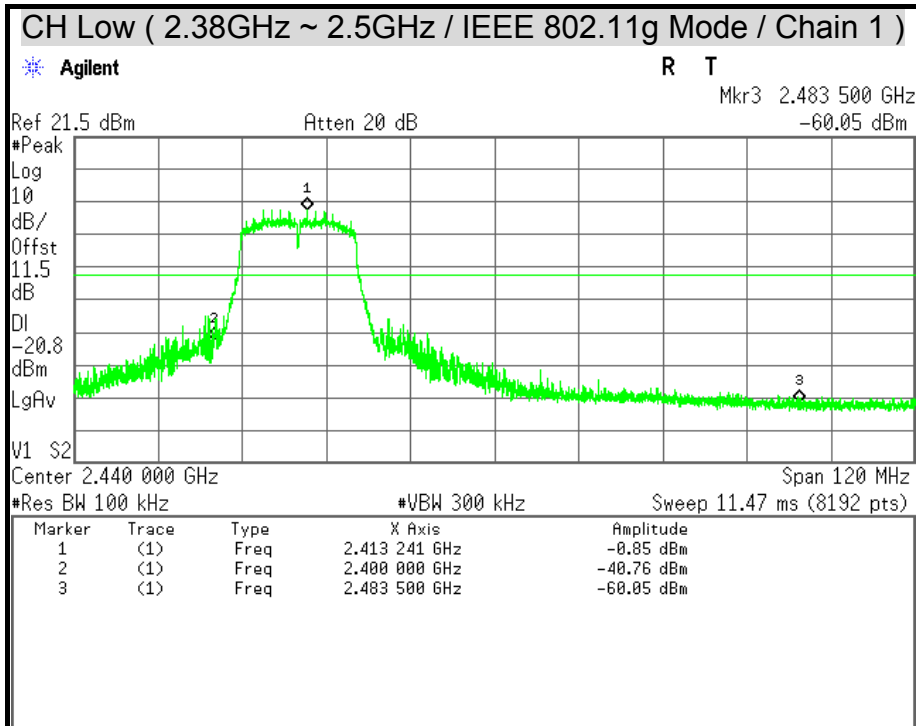

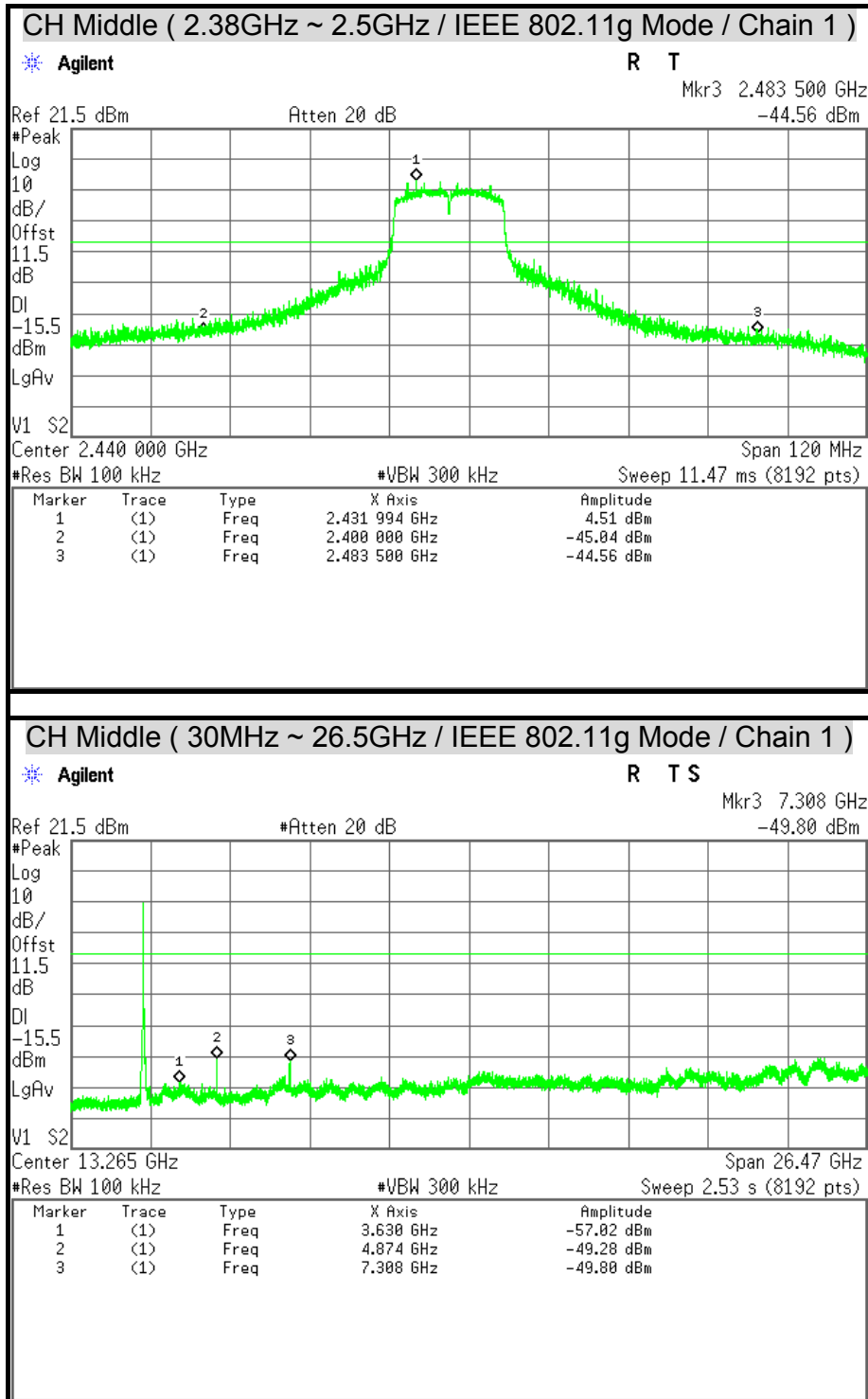

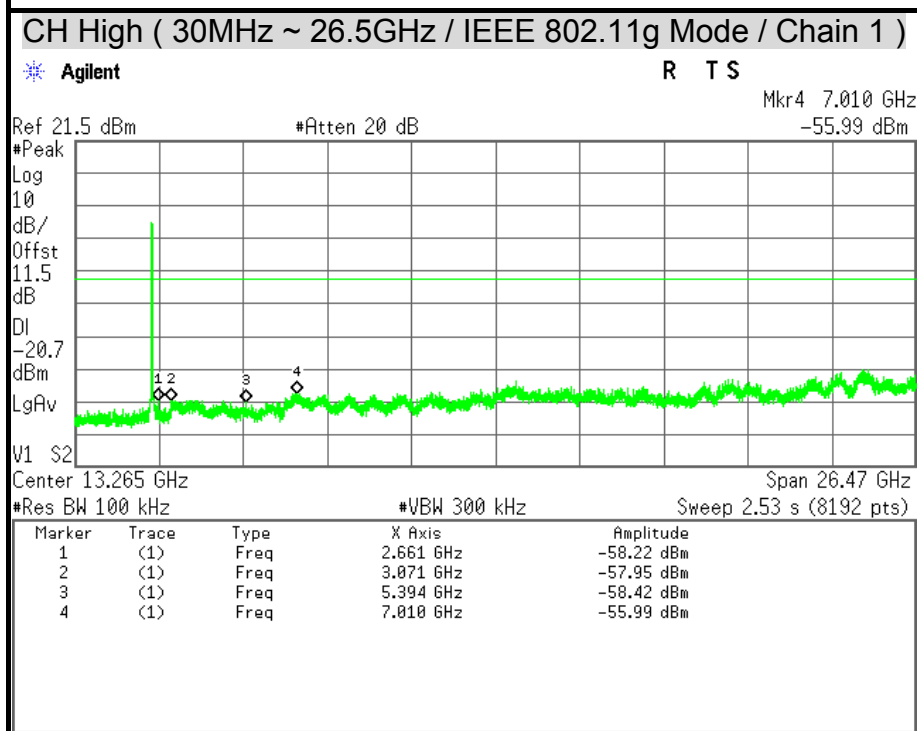
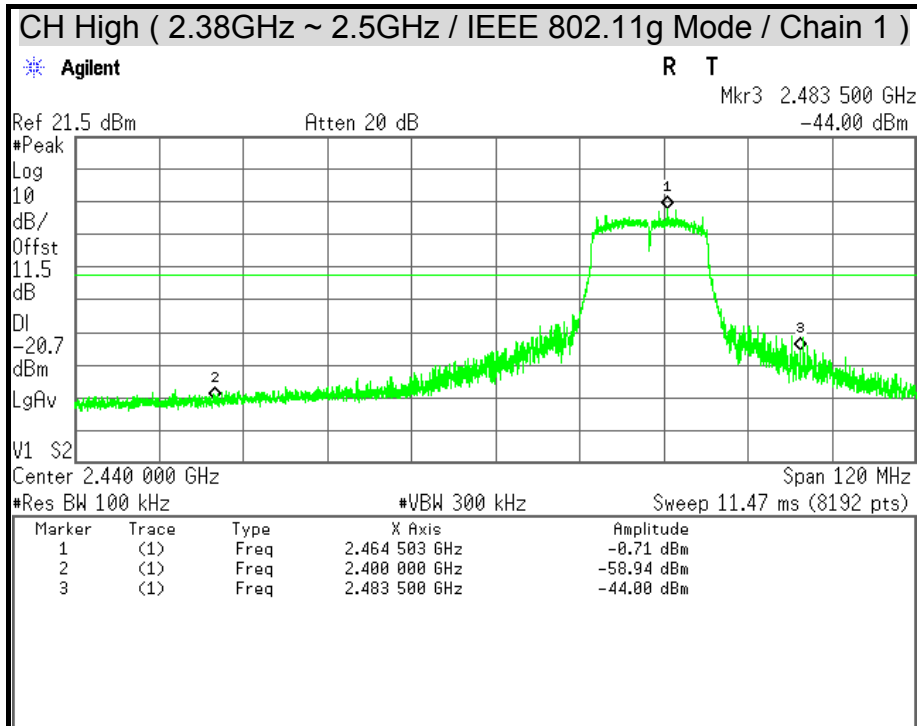

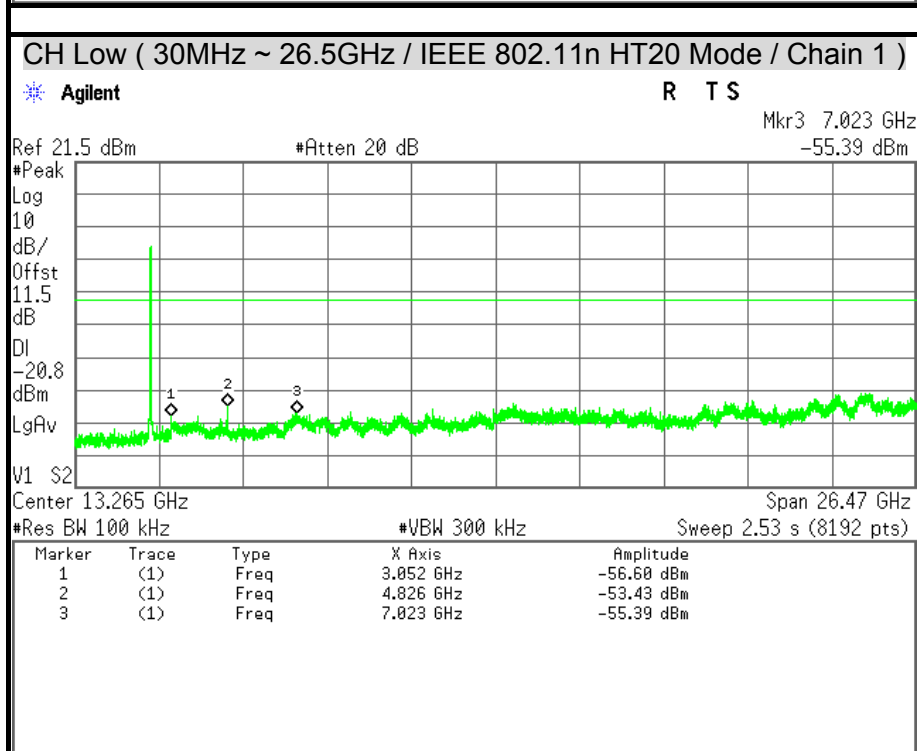
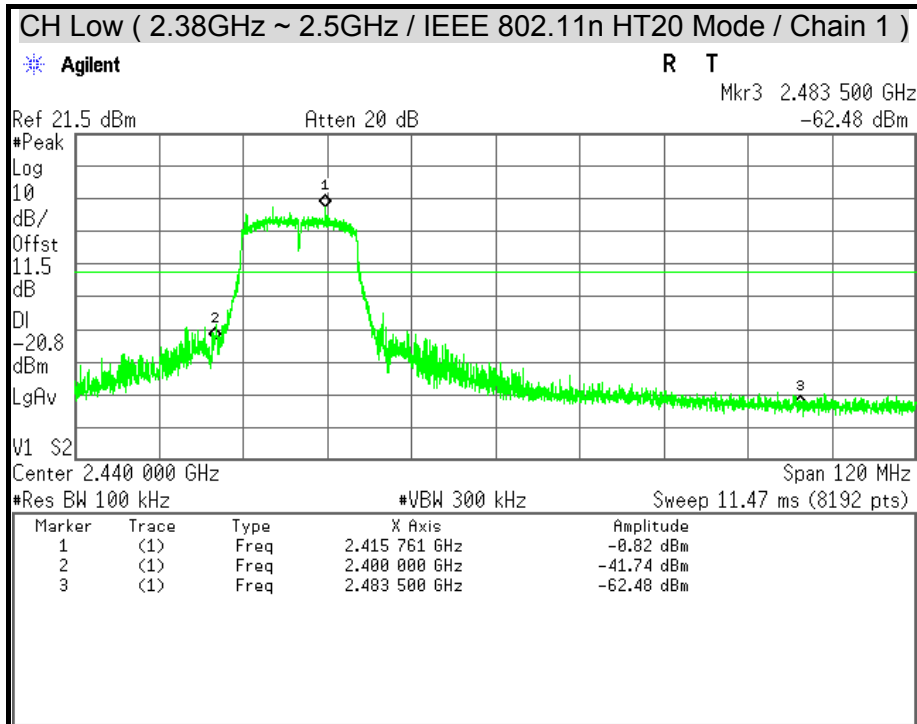

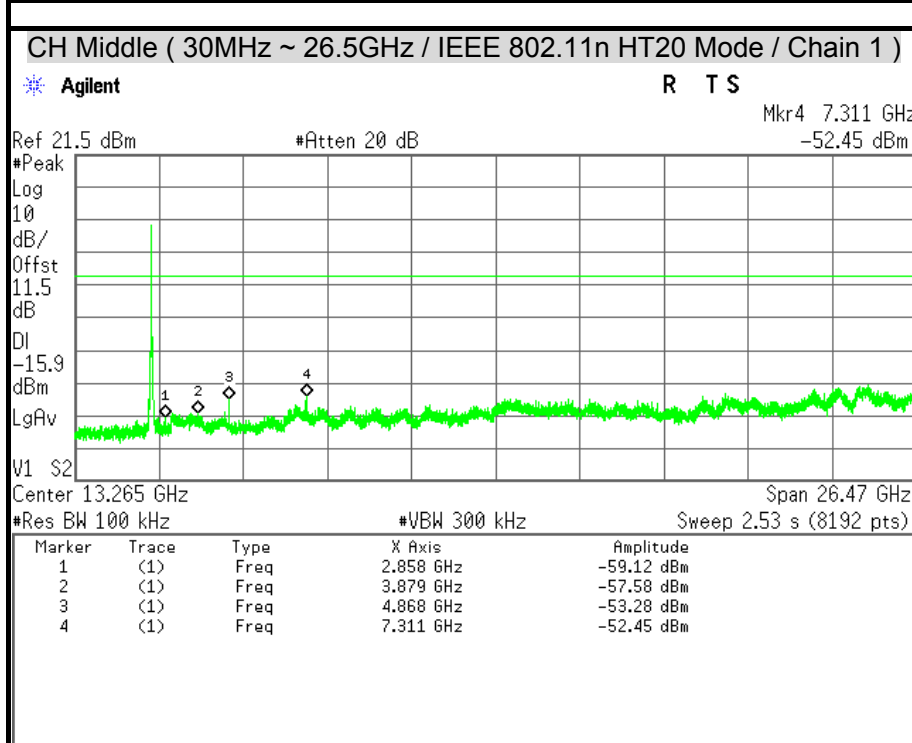
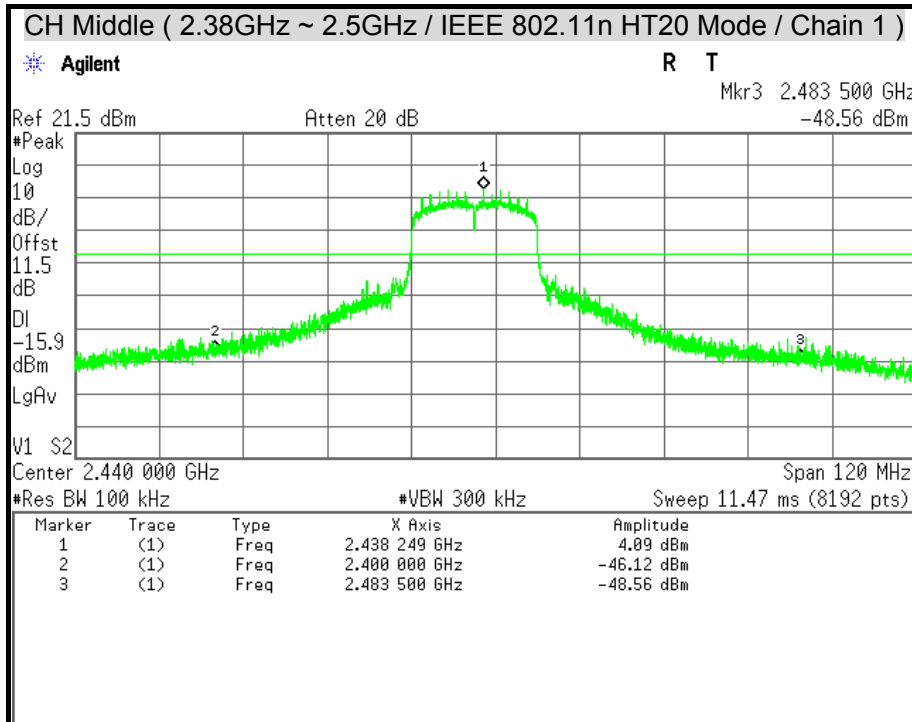

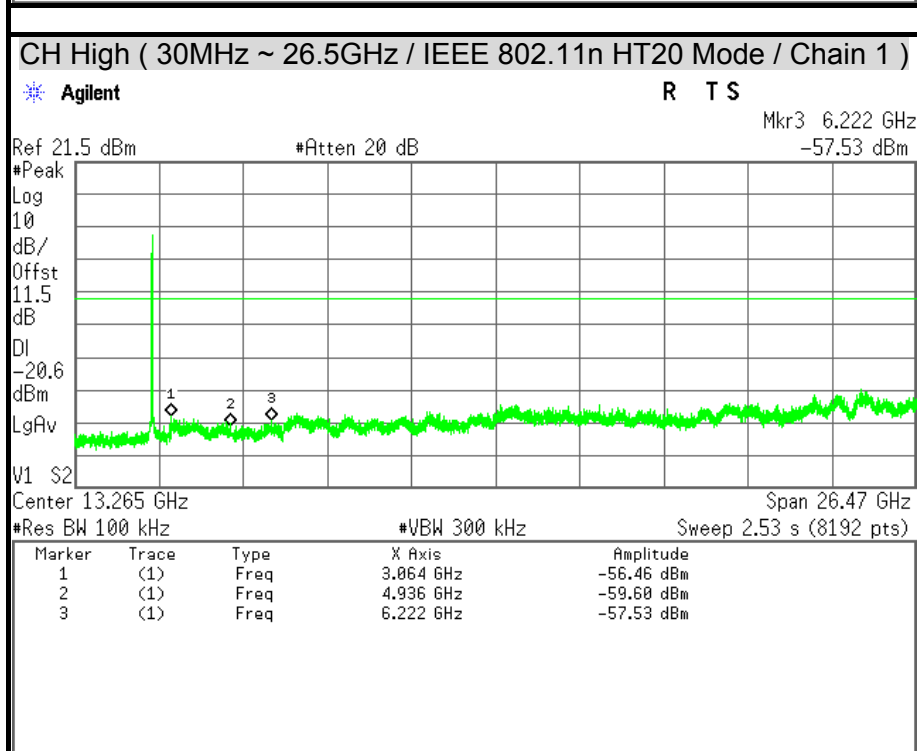
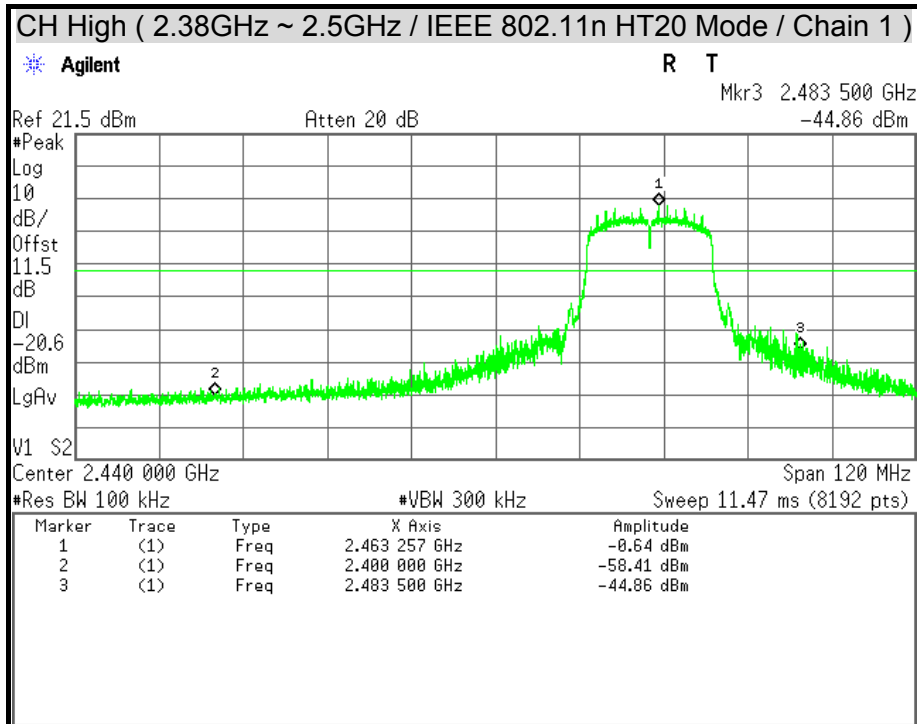

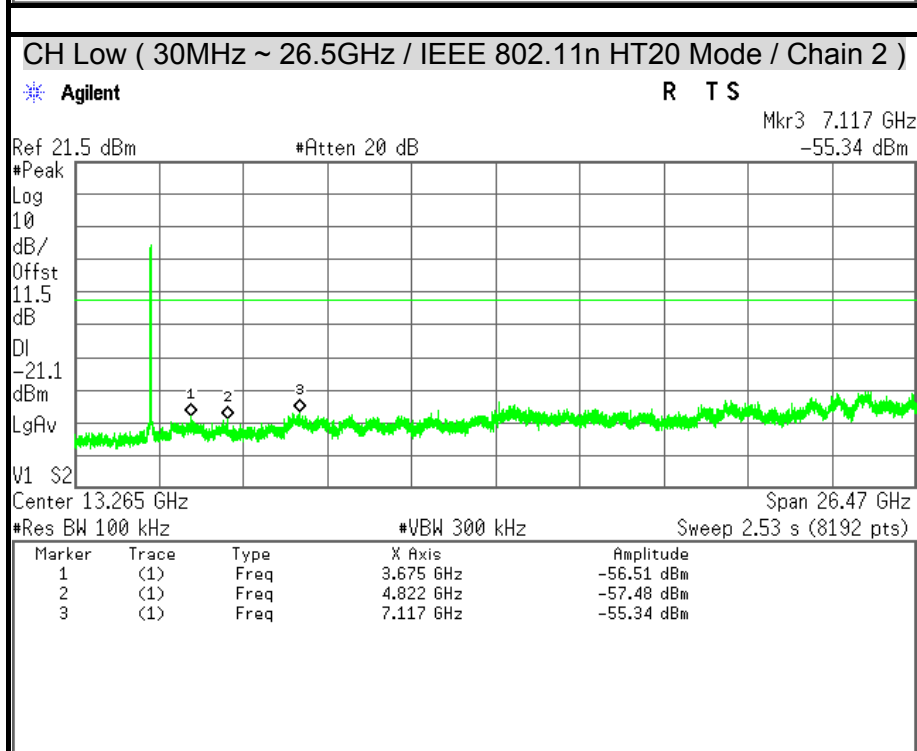
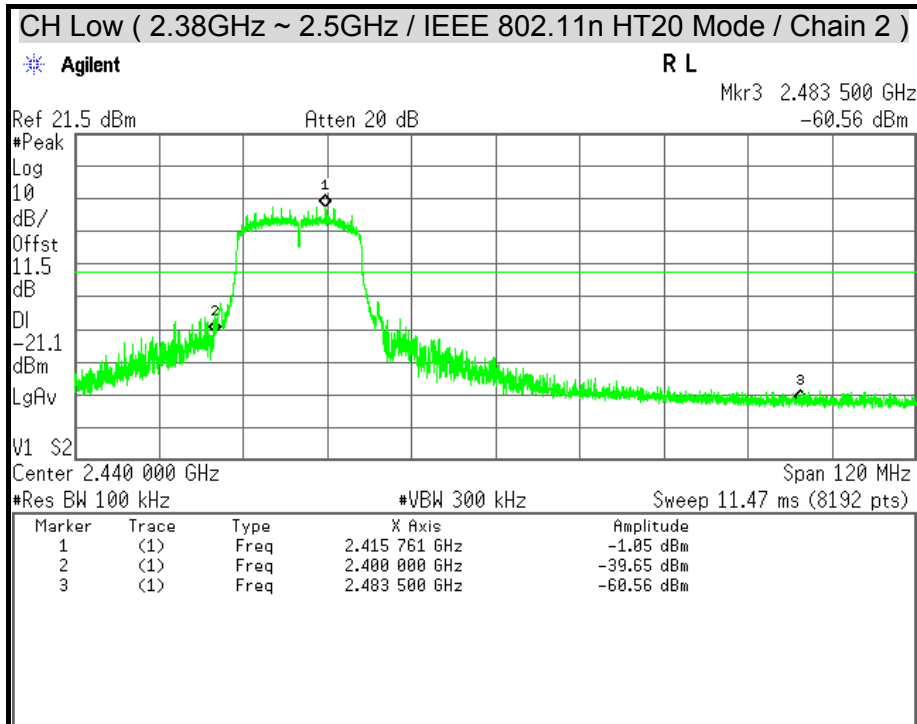

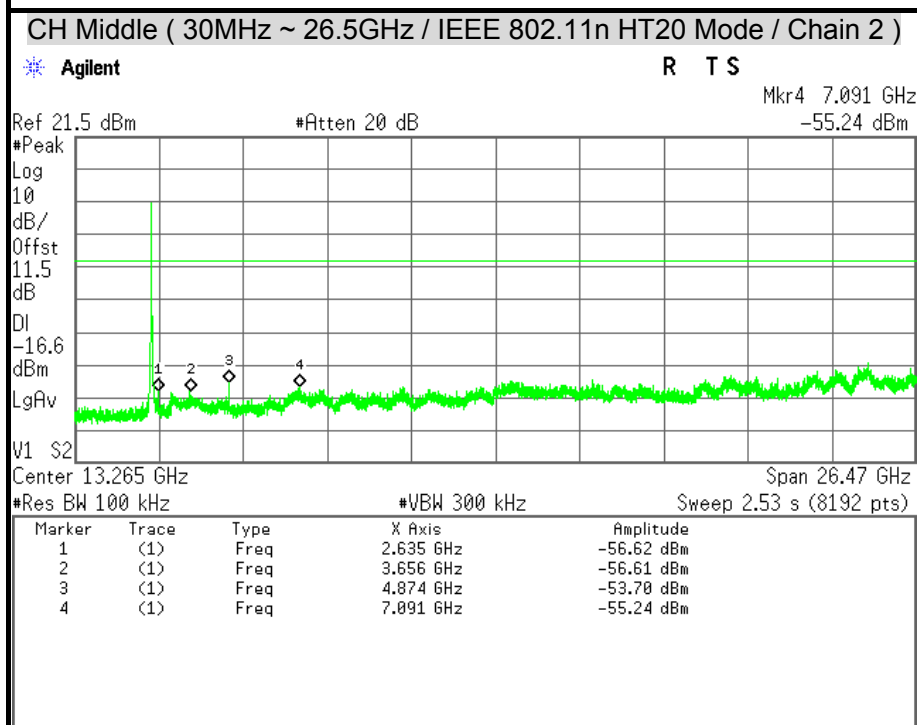
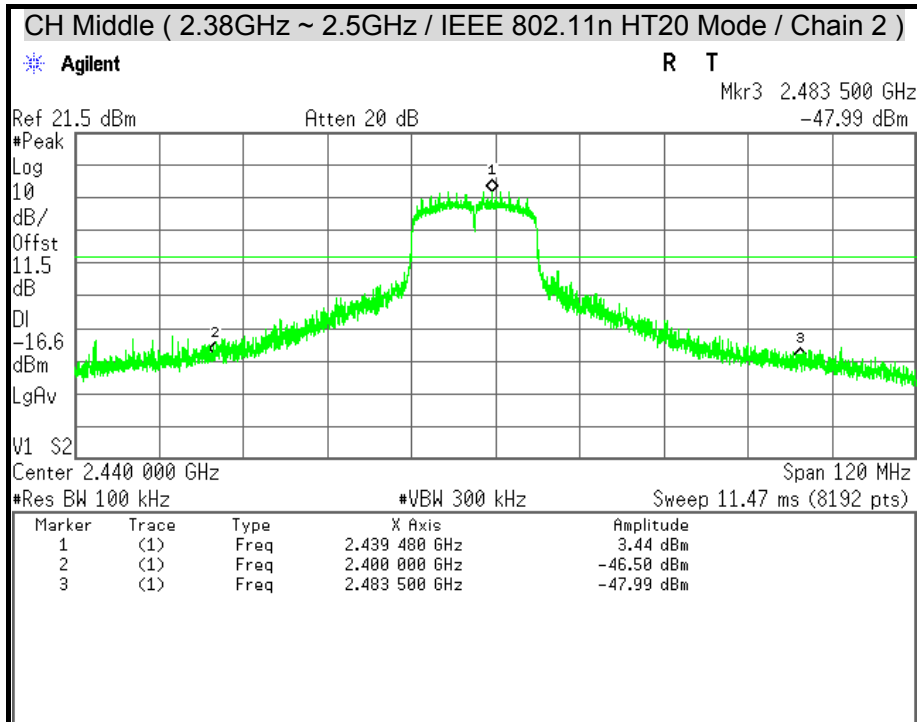

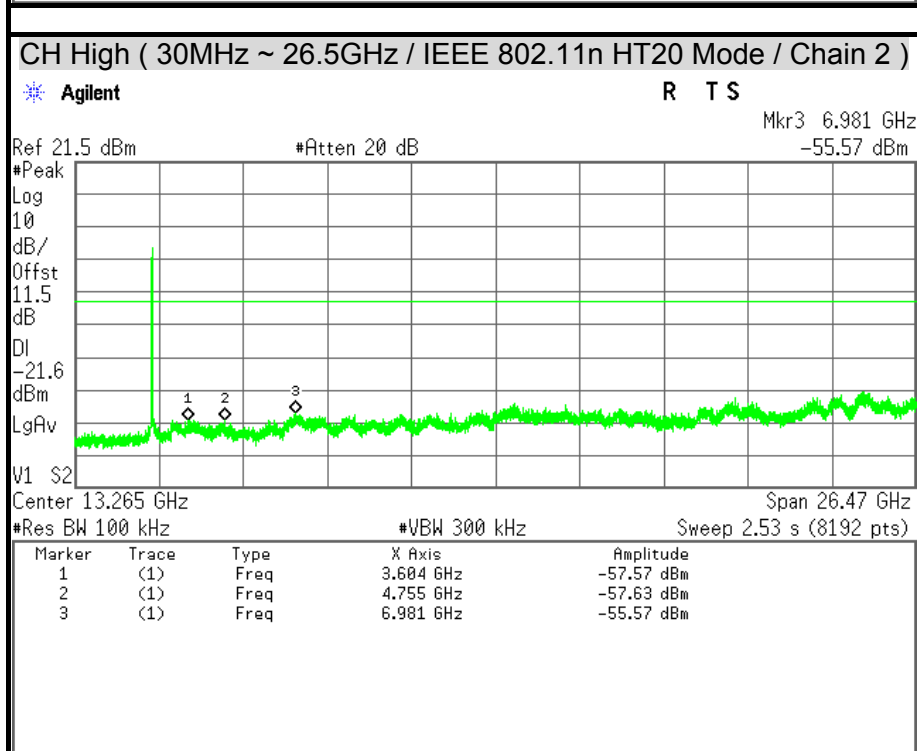
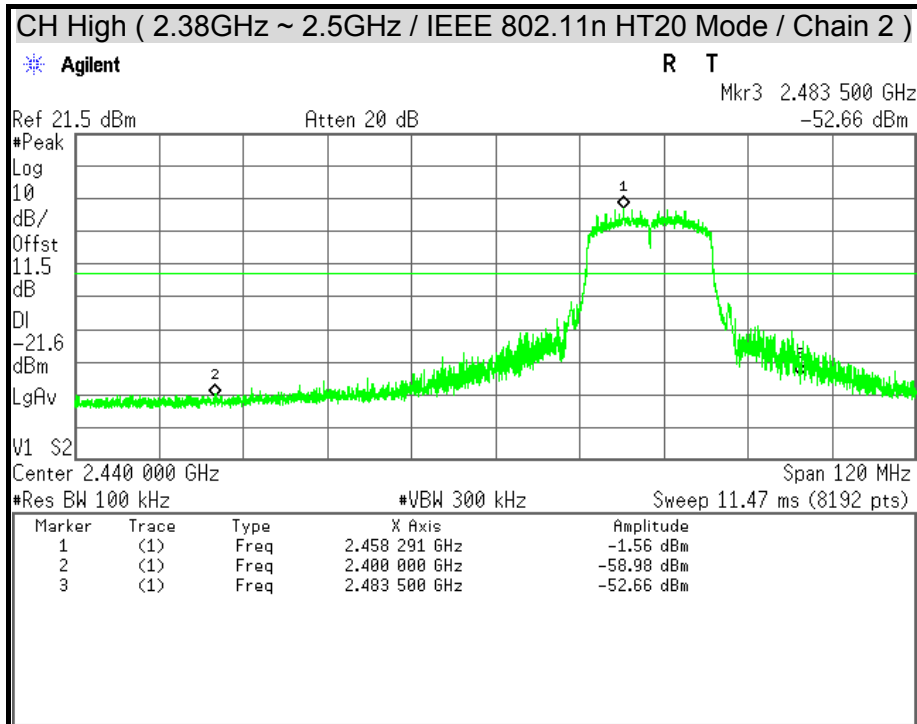

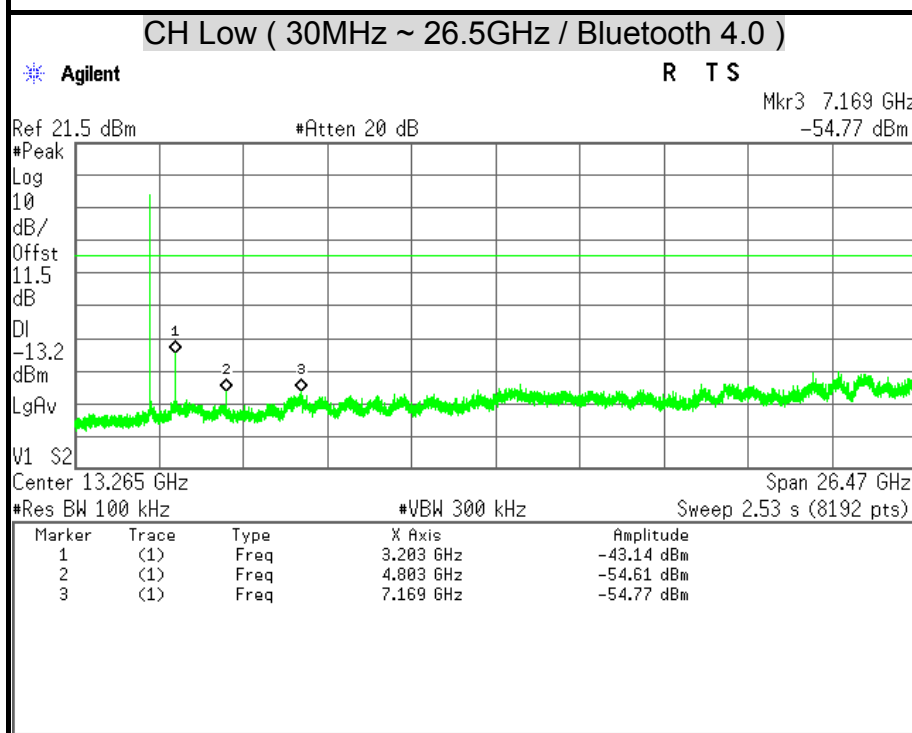
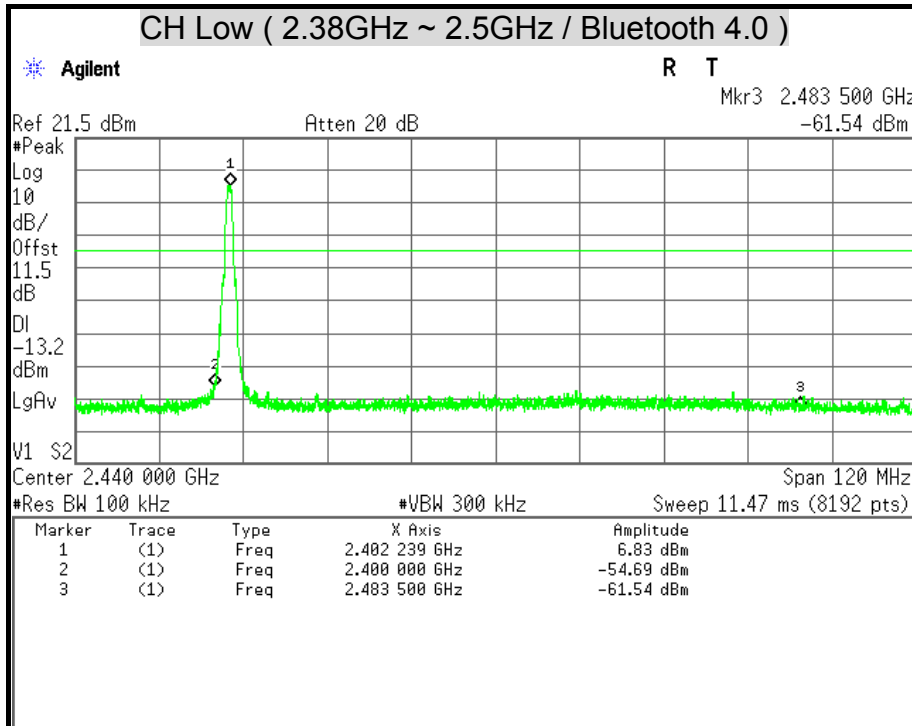

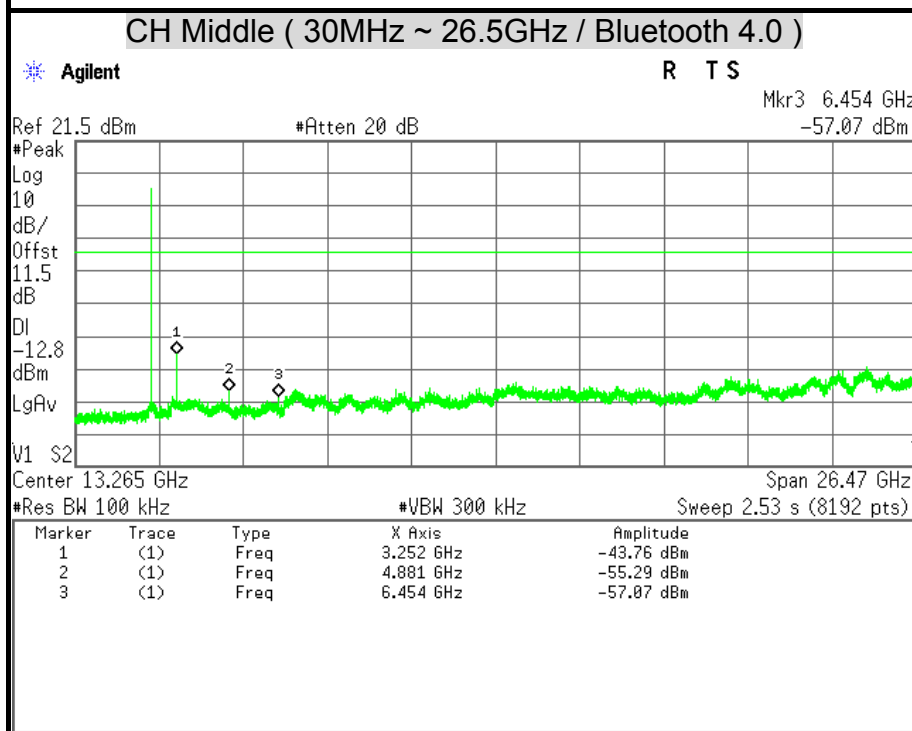
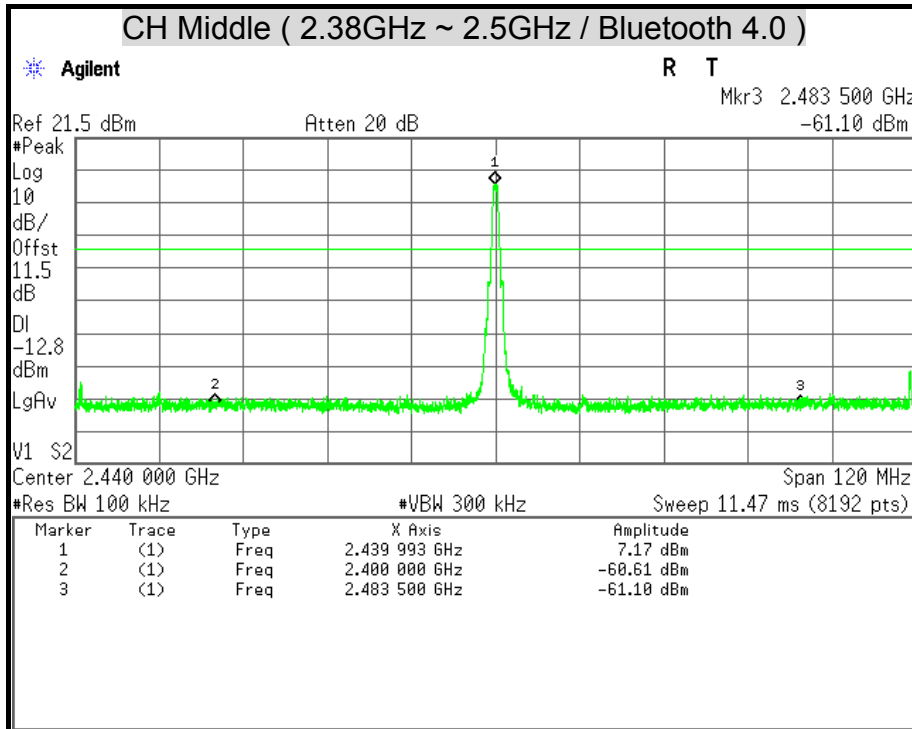

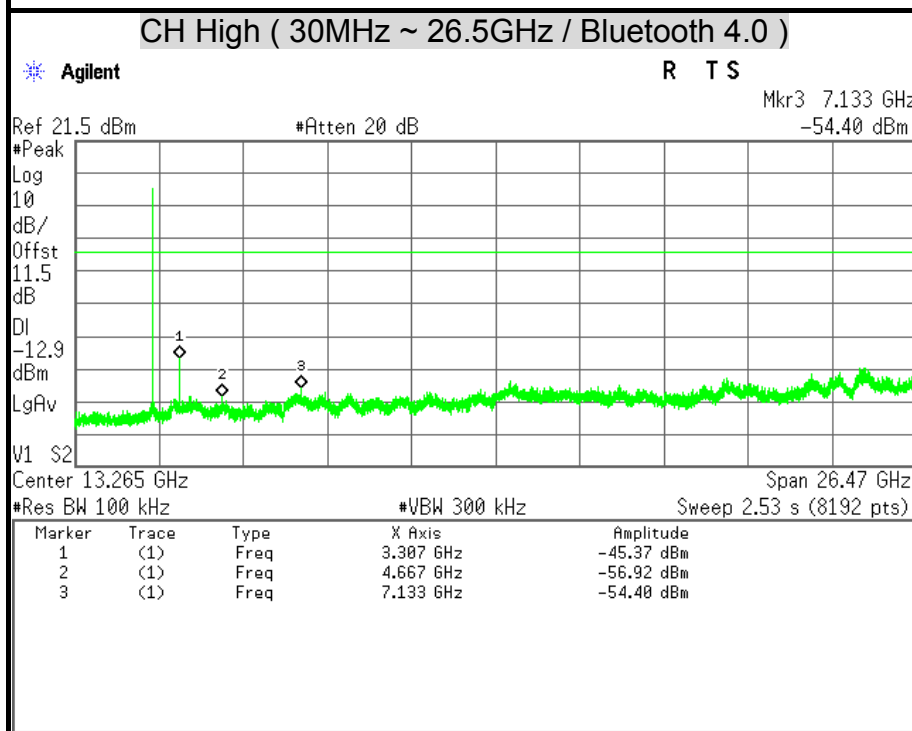
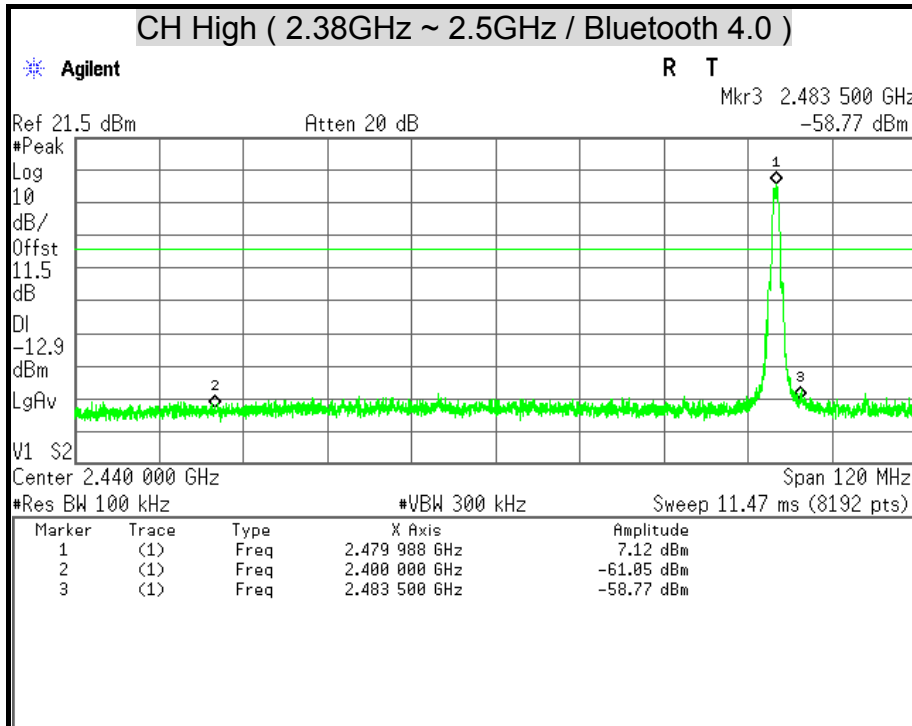



7.6 RADIATED EMISSION

LIMITS

(1) According to § 15.205 (a) Except as shown in paragraph (d) of this section, only spurious emissions are permitted in any of the frequency bands listed below:

MHz	MHz	MHz	GHz
0.090 - 0.110	16.42 - 16.423	399.9 - 410	4.5 - 5.15
¹ 0.495 - 0.505	16.69475 - 16.69525	608 - 614	5.35 - 5.46
2.1735 - 2.1905	16.80425 - 16.80475	960 - 1240	7.25 - 7.75
4.125 - 4.128	25.5 - 25.67	1300 - 1427	8.025 - 8.5
4.17725 - 4.17775	37.5 - 38.25	1435 - 1626.5	9.0 - 9.2
4.20725 - 4.20775	73 - 74.6	1645.5 - 1646.5	9.3 - 9.5
6.215 - 6.218	74.8 - 75.2	1660 - 1710	10.6 - 12.7
6.26775 - 6.26825	108 - 121.94	1718.8 - 1722.2	13.25 - 13.4
6.31175 - 6.31225	123 - 138	2200 - 2300	14.47 - 14.5
8.291 - 8.294	149.9 - 150.05	2310 - 2390	15.35 - 16.2
8.362 - 8.366	156.52475 - 156.52525	2483.5 - 2500	17.7 - 21.4
8.37625 - 8.38675	156.7 - 156.9	2655 - 2900	22.01 - 23.12
8.41425 - 8.41475	162.0125 - 167.17	3260 - 3267	23.6 - 24.0
12.29 - 12.293	167.72 - 173.2	3332 - 3339	31.2 - 31.8
12.51975 - 12.52025	240 - 285	3345.8 - 3338	36.43 - 36.5
12.57675 - 12.57725	322 - 335.4	3600 - 4400	(²)
13.36 - 13.41			

Remark:

- 1. ¹ Until February 1, 1999, this restricted band shall be 0.490-0.510 MHz.
- 2. ² Above 38.6

(2) According to § 15.205 (b) Except as provided in paragraphs (d) and (e), the field strength of emissions appearing within these frequency bands shall not exceed the limits shown in Section 15.209. At frequencies equal to or less than 1000 MHz, compliance with the limits in Section 15.209 shall be demonstrated using measurement instrumentation employing a CISPR quasi-peak detector. Above 1000 MHz, compliance with the emission limits in Section 15.209 shall be demonstrated based on the average value of the measured emissions. The provisions in Section 15.35 apply to these measurements.



(3) According to § 15.209 (a) Except as provided elsewhere in this Subpart, the emissions from an intentional radiator shall not exceed the field strength levels specified in the following table :

Frequency (MHz)	Field Strength (microvolts/meter)	Measurement Distance (meters)
0.009 – 0.490	2400/F(KHz)	300
0.490 – 1.705	24000/F(KHz)	30
1.705 – 30.0	30	30
30 - 88	100 **	3
88 - 216	150 **	3
216 - 960	200 **	3
Above 960	500	3

Remark: **Except as provided in paragraph (g), fundamental emissions from intentional radiators operating under this Section shall not be located in the frequency bands 54-72 MHz, 76-88 MHz, 174-216 MHz or 470-806 MHz. However, operation within these frequency bands is permitted under other sections of this Part, e.g., Sections 15.231 and 15.241.

(4) According to § 15.209 (b) In the emission table above, the tighter limit applies at the band edges.

TEST EQUIPMENT

Radiated Emission / 966Chamber_B

Name of Equipment	Manufacturer	Model	Serial Number	Calibration Due
Spectrum Analyzer	Agilent	E4446A	MY46180323	04/15/2014
EMI Test Receiver	ROHDE & SCHWARZ	ESCI	101131	01/14/2014
Bi-log Antenna	SCHWARZBECK	VULB 9168	9168-250	09/12/2014
Broad-Band Horn Antenna	SCHWARZBECK	BBHA 9120 D	9120D-778	09/12/2014
Double-Ridged Waveguide Horn	ETS-LINDGREN	3117	00078733	12/11/2013
Horn Antenna	COM-POWER	AH-840	03077	12/20/2013
Pre-Amplifier	Agilent	8447D	2944A10052	07/16/2014
Pre-Amplifier	Agilent	8449B	3008A01916	07/16/2014
LOOP Antenna	EMCO	6502	8905-2356	08/20/2014
Notch Filters Band Reject	Micro-Tronics	BRM05702-01	026	N.C.R

Remark: 1. Each piece of equipment is scheduled for calibration once a year.
2. N.C.R = No Calibration Request.



TEST SETUP

The diagram below shows the test setup that is utilized to make the measurements for emission from below 1GHz.

9kHz ~ 30MHz

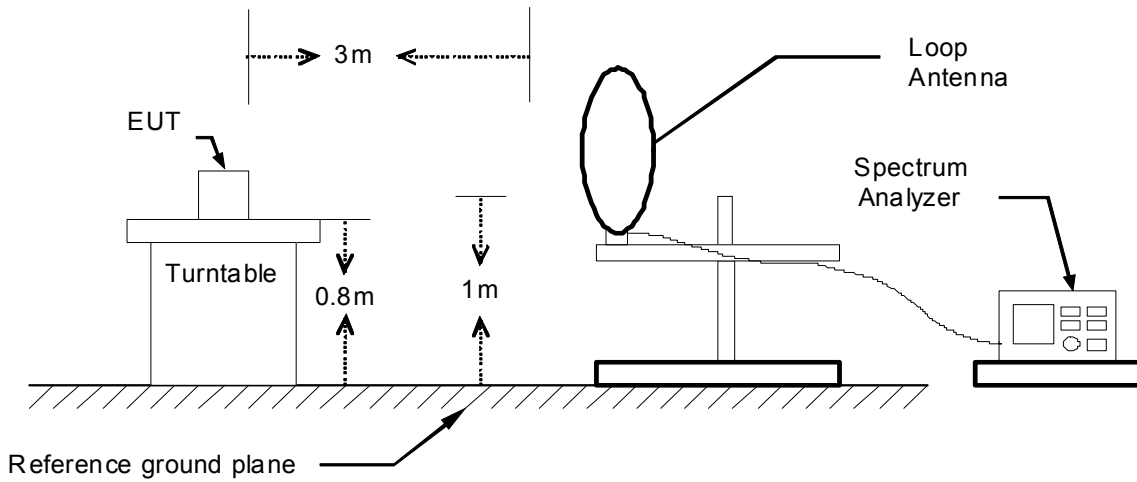

30MHz ~ 1GHz

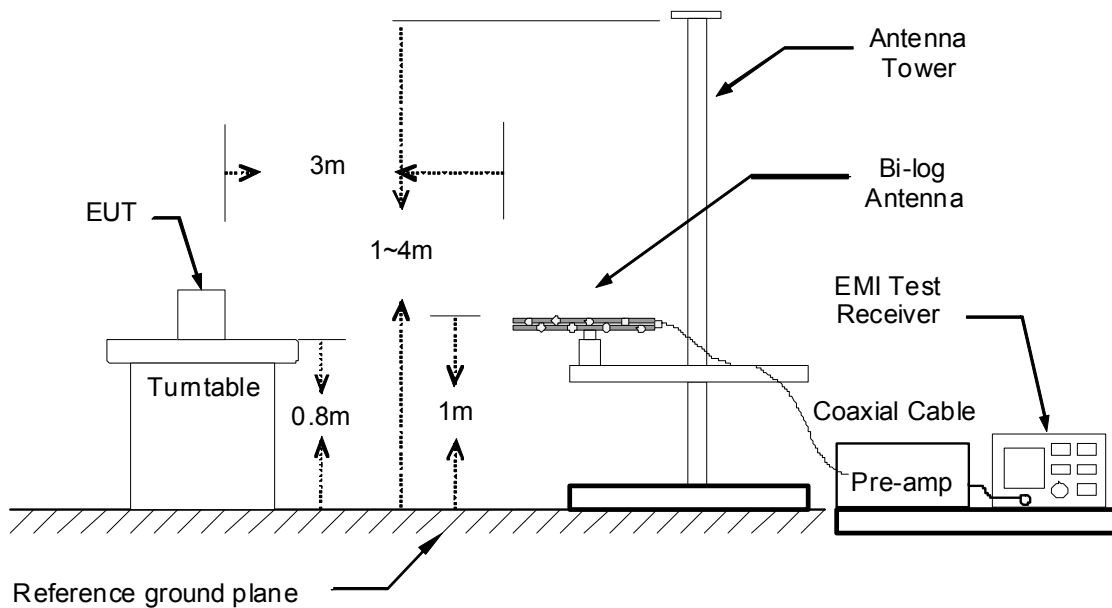



The diagram below shows the test setup that is utilized to make the measurements for emission above 1GHz.

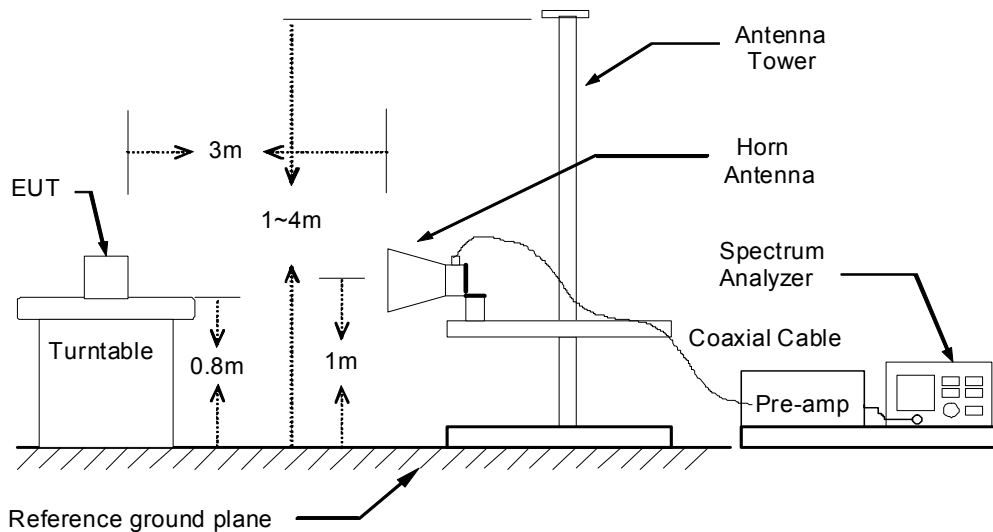

TEST PROCEDURE

1. The EUT was placed on the top of a rotating table 0.8 meters above the ground. The table was rotated 360 degrees to determine the position of the highest radiation.
2. While measuring the radiated emission below 1GHz, the EUT was set 3 meters away from the interference-receiving antenna, which was mounted on the top of a variable-height antenna tower. While measuring the radiated emission above 1GHz, the EUT was set 3 meters away from the interference-receiving antenna.
3. The antenna is a broadband antenna, and its height is varied from one meter to four meters above the ground to determine the maximum value of the field strength. Both horizontal and vertical polarization of the antenna are set to make the measurement.
4. For each suspected emission, the EUT was arranged to its worst case and then the antenna was tuned to heights from 1 meter to 4 meters and the table was turned from 0 degrees to 360 degrees to find the maximum reading.
5. The test-receiver system was set to Peak Detect Function and Specified Bandwidth with Maximum Hold Mode.
6. If the emission level of the EUT in peak mode was 10 dB lower than the limit specified, then testing could be stopped and the peak values of the EUT would be reported. Otherwise the emissions that did not have 10 dB margin would be re-tested one by one using peak, quasi-peak or average method as specified and then reported in a data sheet.

Remark :

1. The resolution bandwidth and video bandwidth of test receiver/spectrum analyzer is 120 KHz for Peak detection (PK) and Quasi-peak detection (QP) at frequency below 1GHz.
2. The resolution bandwidth and video bandwidth of test receiver/spectrum analyzer is 1 MHz for Peak detection and frequency above 1GHz.
3. The resolution bandwidth of test receiver/spectrum analyzer is 1 MHz and the video bandwidth is 10 Hz for Average detection (AV) at frequency above 1GHz.



TEST RESULTS

Below 1 GHz (9kHz ~ 30MHz)

No emission found between lowest internal used/generated frequency to 30MHz.

Below 1 GHz (30MHz ~ 1GHz)

Product Name	Nuvola	Test By	Rueyyan Lin
Test Model	NP-1	Test Date	2013/11/14
Test Mode	IEEE 802.11a TX / CH Low	Temp. & Humidity	24°C, 51%

966 Chamber_B at 3Meter / Horizontal						
Frequency (MHz)	Reading (dBµV)	Correction Factor (dB/m)	Result (dBµV/m)	Limit (dBµV/m)	Margin (dB)	Remark
93.05	49.14	-19.56	29.58	43.50	-13.92	Peak
241.46	42.72	-14.04	28.68	46.00	-17.32	Peak
349.13	42.77	-10.91	31.86	46.00	-14.14	Peak
432.55	40.67	-9.23	31.45	46.00	-14.55	Peak
744.89	34.66	-3.69	30.97	46.00	-15.03	Peak
860.32	40.22	-1.92	38.30	46.00	-7.70	Peak
1000.00	34.83	0.37	35.20	74.00	-38.80	Peak

966 Chamber_B at 3Meter / Vertical						
Frequency (MHz)	Reading (dBµV)	Correction Factor (dB/m)	Result (dBµV/m)	Limit (dBµV/m)	Margin (dB)	Remark
40.67	46.30	-14.40	31.90	40.00	-8.10	Peak
62.01	42.35	-14.48	27.86	40.00	-12.14	Peak
116.33	47.37	-16.57	30.80	43.50	-12.70	Peak
216.24	42.34	-15.59	26.75	46.00	-19.25	Peak
432.55	40.31	-9.23	31.08	46.00	-14.92	Peak
732.28	32.93	-3.98	28.94	46.00	-17.06	Peak
865.17	33.67	-1.83	31.84	46.00	-14.16	Peak
1000.00	34.61	0.37	34.98	74.00	-39.02	Peak

Remark:

1. Quasi-peak test would be performed if the peak result were greater than the quasi-peak limit.
2. Data of measurement within this frequency range shown " --- " in the table above means the reading of emissions are attenuated more than 20dB below the permissible limits or the field strength is too small to be measured.
3. Correction Factor (dB/m) = Antenna Factor (dB/m) + Cable Loss (dB) – PreAmp.Gain (dB)
4. Result (dBuV/m) = Reading (dBuV) + Correction Factor (dB/m)
5. Margin (dB) = Remark result (dBuV/m) - Quasi-peak limit (dBuV/m).



Product Name	Nuvola	Test By	Rueyyan Lin
Test Model	NP-1	Test Date	2013/11/09
Test Mode	IEEE 802.11b TX / CH Low	Temp. & Humidity	26°C, 48%

966 Chamber_B at 3Meter / Horizontal						
Frequency (MHz)	Reading (dBμV)	Correction Factor (dB/m)	Result (dBμV/m)	Limit (dBμV/m)	Margin (dB)	Remark
30.00	43.36	-15.45	27.91	40.00	-12.09	Peak
94.02	50.32	-19.43	30.89	43.50	-12.61	Peak
134.76	44.47	-14.50	29.96	43.50	-13.54	Peak
250.19	48.38	-13.71	34.67	46.00	-11.33	Peak
308.39	43.68	-11.74	31.94	46.00	-14.06	Peak
499.48	43.74	-8.21	35.53	46.00	-10.47	Peak
862.26	42.86	-1.88	40.98	46.00	-5.02	QP
1000.00	39.68	0.37	40.05	74.00	-33.95	Peak

966 Chamber_B at 3Meter / Vertical						
Frequency (MHz)	Reading (dBμV)	Correction Factor (dB/m)	Result (dBμV/m)	Limit (dBμV/m)	Margin (dB)	Remark
30.97	52.09	-15.38	36.71	40.00	-3.29	Peak
123.12	53.42	-15.77	37.65	43.50	-5.85	Peak
181.32	46.52	-14.76	31.75	43.50	-11.75	Peak
308.39	46.79	-11.74	35.06	46.00	-10.94	Peak
494.63	41.46	-8.27	33.19	46.00	-12.81	Peak
861.29	38.54	-1.90	36.64	46.00	-9.36	Peak
1000.00	36.10	0.37	36.47	74.00	-37.53	Peak

Remark:

1. Quasi-peak test would be performed if the peak result were greater than the quasi-peak limit.
2. Data of measurement within this frequency range shown " --- " in the table above means the reading of emissions are attenuated more than 20dB below the permissible limits or the field strength is too small to be measured.
3. Correction Factor (dB/m) = Antenna Factor (dB/m) + Cable Loss (dB) – PreAmp.Gain (dB)
4. Result (dBuV/m) = Reading (dBuV) + Correction Factor (dB/m)
5. Margin (dB) = Remark result (dBuV/m) - Quasi-peak limit (dBuV/m).



Product Name	Nuvola	Test By	Rueyyan Lin
Test Model	NP-1	Test Date	2013/11/09
Test Mode	Bluetooth 4.0 / TX Mode / CH Low	Temp. & Humidity	26 °C, 48%

966 Chamber_B at 3Meter / Horizontal						
Frequency (MHz)	Reading (dBμV)	Correction Factor (dB/m)	Result (dBμV/m)	Limit (dBμV/m)	Margin (dB)	Remark
30.00	47.18	-15.45	31.73	40.00	-8.27	Peak
134.76	44.41	-14.50	29.91	43.50	-13.59	Peak
189.08	47.51	-15.30	32.21	43.50	-11.29	Peak
250.19	47.94	-13.71	34.23	46.00	-11.77	Peak
378.23	39.56	-10.35	29.21	46.00	-16.79	Peak
500.45	38.23	-8.19	30.04	46.00	-15.96	Peak
860.32	39.40	-1.92	37.48	46.00	-8.52	Peak
1000.00	36.25	0.37	36.62	74.00	-37.38	Peak

966 Chamber_B at 3Meter / Vertical						
Frequency (MHz)	Reading (dBμV)	Correction Factor (dB/m)	Result (dBμV/m)	Limit (dBμV/m)	Margin (dB)	Remark
31.94	49.74	-15.30	34.44	40.00	-5.56	QP
121.18	52.02	-15.98	36.04	43.50	-7.46	Peak
309.36	46.09	-11.72	34.37	46.00	-11.63	Peak
498.51	40.59	-8.22	32.37	46.00	-13.63	Peak
533.43	39.75	-7.68	32.07	46.00	-13.93	Peak
833.16	36.36	-2.45	33.91	46.00	-12.09	Peak
1000.00	36.31	0.37	36.68	74.00	-37.32	Peak

Remark:

1. Quasi-peak test would be performed if the peak result were greater than the quasi-peak limit.
2. Data of measurement within this frequency range shown " --- " in the table above means the reading of emissions are attenuated more than 20dB below the permissible limits or the field strength is too small to be measured.
3. Correction Factor (dB/m) = Antenna Factor (dB/m) + Cable Loss (dB) – PreAmp.Gain (dB)
4. Result (dBuV/m) = Reading (dBuV) + Correction Factor (dB/m)
5. Margin (dB) = Remark result (dBuV/m) - Quasi-peak limit (dBuV/m).



Above 1 GHz

Product Name	Nuvola	Test By	Rueyyan Lin
Test Model	NP-1	Test Date	2013/11/06
Test Mode	IEEE 802.11a TX / CH Low	Temp. & Humidity	26°C, 43%

966 Chamber_B at 3Meter / Horizontal									
Frequency (MHz)	Reading-PK (dBuV)	Reading-AV (dBuV)	Correction Factor (dB/m)	Result-PK (dBuV/m)	Result-AV (dBuV/m)	Limit-PK (dBuV/m)	Limit-AV (dBuV/m)	Margin (dB)	Remark
1060.00	54.70	---	-4.34	50.36	---	74.00	54.00	-3.64	Peak
1255.00	54.06	---	-3.88	50.18	---	74.00	54.00	-3.82	Peak
1400.00	53.87	---	-3.54	50.33	---	74.00	54.00	-3.67	Peak
1600.00	53.90	---	-2.20	51.71	---	74.00	54.00	-2.29	Peak
6156.00	37.05	---	11.53	48.58	---	74.00	54.00	-5.42	Peak
6744.00	38.22	---	12.40	50.62	---	74.00	54.00	-3.38	Peak
7656.00	37.29	---	13.78	51.07	---	74.00	54.00	-2.93	Peak

966 Chamber_B at 3Meter / Vertical									
Frequency (MHz)	Reading-PK (dBuV)	Reading-AV (dBuV)	Correction Factor (dB/m)	Result-PK (dBuV/m)	Result-AV (dBuV/m)	Limit-PK (dBuV/m)	Limit-AV (dBuV/m)	Margin (dB)	Remark
1090.00	55.12	---	-4.27	50.86	---	74.00	54.00	-3.14	Peak
1355.00	53.86	---	-3.64	50.21	---	74.00	54.00	-3.79	Peak
1460.00	54.03	---	-3.39	50.64	---	74.00	54.00	-3.36	Peak
1600.00	52.58	---	-2.20	50.38	---	74.00	54.00	-3.62	Peak
6216.00	37.45	---	11.69	49.14	---	74.00	54.00	-4.86	Peak
6768.00	37.17	---	12.39	49.57	---	74.00	54.00	-4.43	Peak
7752.00	37.75	---	13.72	51.48	---	74.00	54.00	-2.52	Peak

Remark:

1. Measuring frequencies from 1 GHz to the 10th harmonic of highest fundamental frequency.
2. Average test would be performed if the peak result were greater than the average limit.
3. Data of measurement within this frequency range shown " --- " in the table above means the reading of emissions are attenuated more than 20dB below the permissible limits or the field strength is too small to be measured.
4. Measurements above show only up to 6 maximum emissions noted, or would be lesser, with " N/A " remark, if no specific emissions from the EUT are recorded (ie: margin>20dB from the applicable limit) and considered that's already beyond the background noise floor.
5. Result = Reading + Correction Factor
Margin = Result - Limit
Remark Peak = Result(PK) - Limit(AV)
Remark AVG = Result(AV) - Limit(AV)



Product Name	Nuvola	Test By	Rueyyan Lin
Test Model	NP-1	Test Date	2013/11/06
Test Mode	IEEE 802.11a TX / CH Middle	Temp. & Humidity	26°C, 43%

966 Chamber_B at 3Meter / Horizontal									
Frequency (MHz)	Reading-PK (dBuV)	Reading-AV (dBuV)	Correction Factor (dB/m)	Result-PK (dBuV/m)	Result-AV (dBuV/m)	Limit-PK (dBuV/m)	Limit-AV (dBuV/m)	Margin (dB)	Remark
1005.00	55.27	---	-4.47	50.80	---	74.00	54.00	-3.20	Peak
1245.00	53.98	---	-3.90	50.07	---	74.00	54.00	-3.93	Peak
1395.00	54.20	---	-3.55	50.65	---	74.00	54.00	-3.35	Peak
1610.00	53.42	---	-2.09	51.33	---	74.00	54.00	-2.67	Peak
6144.00	36.88	---	11.49	48.38	---	74.00	54.00	-5.62	Peak
6708.00	37.52	---	12.41	49.93	---	74.00	54.00	-4.07	Peak
7500.00	37.98	---	13.88	51.86	---	74.00	54.00	-2.14	Peak

966 Chamber_B at 3Meter / Vertical									
Frequency (MHz)	Reading-PK (dBuV)	Reading-AV (dBuV)	Correction Factor (dB/m)	Result-PK (dBuV/m)	Result-AV (dBuV/m)	Limit-PK (dBuV/m)	Limit-AV (dBuV/m)	Margin (dB)	Remark
1005.00	54.71	---	-4.47	50.25	---	74.00	54.00	-3.75	Peak
1170.00	54.12	---	-4.08	50.04	---	74.00	54.00	-3.96	Peak
1350.00	54.66	---	-3.65	51.01	---	74.00	54.00	-2.99	Peak
1605.00	53.60	---	-2.14	51.46	---	74.00	54.00	-2.54	Peak
6144.00	37.25	---	11.49	48.74	---	74.00	54.00	-5.26	Peak
6768.00	37.88	---	12.39	50.28	---	74.00	54.00	-3.72	Peak
7764.00	37.76	---	13.72	51.48	---	74.00	54.00	-2.52	Peak

Remark:

1. Measuring frequencies from 1 GHz to the 10th harmonic of highest fundamental frequency.
2. Average test would be performed if the peak result were greater than the average limit.
3. Data of measurement within this frequency range shown " --- " in the table above means the reading of emissions are attenuated more than 20dB below the permissible limits or the field strength is too small to be measured.
4. Measurements above show only up to 6 maximum emissions noted, or would be lesser, with " N/A " remark, if no specific emissions from the EUT are recorded (ie: margin>20dB from the applicable limit) and considered that's already beyond the background noise floor.
5. Result = Reading + Correction Factor
Margin = Result - Limit
Remark Peak = Result(PK) - Limit(AV)
Remark AVG = Result(AV) - Limit(AV)



Product Name	Nuvola	Test By	Rueyyan Lin
Test Model	NP-1	Test Date	2013/11/06
Test Mode	IEEE 802.11a TX / CH High	Temp. & Humidity	25°C, 43%

966 Chamber_B at 3Meter / Horizontal									
Frequency (MHz)	Reading-PK (dBuV)	Reading-AV (dBuV)	Correction Factor (dB/m)	Result-PK (dBuV/m)	Result-AV (dBuV/m)	Limit-PK (dBuV/m)	Limit-AV (dBuV/m)	Margin (dB)	Remark
1050.00	55.13	---	-4.36	50.76	---	74.00	54.00	-3.24	Peak
1180.00	53.98	---	-4.06	49.92	---	74.00	54.00	-4.08	Peak
1405.00	53.98	---	-3.52	50.46	---	74.00	54.00	-3.54	Peak
1680.00	53.30	---	-1.31	51.99	---	74.00	54.00	-2.01	Peak
6168.00	37.41	---	11.56	48.97	---	74.00	54.00	-5.03	Peak
6660.00	38.40	---	12.43	50.83	---	74.00	54.00	-3.17	Peak
7524.00	38.40	---	13.87	52.26	---	74.00	54.00	-1.74	Peak

966 Chamber_B at 3Meter / Vertical									
Frequency (MHz)	Reading-PK (dBuV)	Reading-AV (dBuV)	Correction Factor (dB/m)	Result-PK (dBuV/m)	Result-AV (dBuV/m)	Limit-PK (dBuV/m)	Limit-AV (dBuV/m)	Margin (dB)	Remark
1050.00	55.48	---	-4.36	51.12	---	74.00	54.00	-2.88	Peak
1185.00	53.42	---	-4.04	49.38	---	74.00	54.00	-4.62	Peak
1310.00	54.75	---	-3.75	51.00	---	74.00	54.00	-3.00	Peak
1550.00	53.02	---	-2.75	50.28	---	74.00	54.00	-3.72	Peak
6168.00	37.31	---	11.56	48.88	---	74.00	54.00	-5.12	Peak
6912.00	37.85	---	12.35	50.21	---	74.00	54.00	-3.79	Peak
7764.00	38.53	---	13.72	52.25	---	74.00	54.00	-1.75	Peak

Remark:

1. Measuring frequencies from 1 GHz to the 10th harmonic of highest fundamental frequency.
2. Average test would be performed if the peak result were greater than the average limit.
3. Data of measurement within this frequency range shown " --- " in the table above means the reading of emissions are attenuated more than 20dB below the permissible limits or the field strength is too small to be measured.
4. Measurements above show only up to 6 maximum emissions noted, or would be lesser, with " N/A " remark, if no specific emissions from the EUT are recorded (ie: margin>20dB from the applicable limit) and considered that's already beyond the background noise floor.
5. Result = Reading + Correction Factor
Margin = Result - Limit
Remark Peak = Result(PK) - Limit(AV)
Remark AVG = Result(AV) - Limit(AV)



Product Name	Nuvola	Test By	Rueyyan Lin
Test Model	NP-1	Test Date	2013/11/06
Test Mode	IEEE 802.11an HT20 TX / CH Low	Temp. & Humidity	25°C, 43%

966 Chamber_B at 3Meter / Horizontal									
Frequency (MHz)	Reading-PK (dBuV)	Reading-AV (dBuV)	Correction Factor (dB/m)	Result-PK (dBuV/m)	Result-AV (dBuV/m)	Limit-PK (dBuV/m)	Limit-AV (dBuV/m)	Margin (dB)	Remark
1030.00	54.76	---	-4.41	50.35	---	74.00	54.00	-3.65	Peak
1215.00	55.05	---	-3.97	51.08	---	74.00	54.00	-2.92	Peak
1335.00	54.24	---	-3.69	50.56	---	74.00	54.00	-3.44	Peak
1600.00	53.45	---	-2.20	51.25	---	74.00	54.00	-2.75	Peak
6096.00	37.48	---	11.36	48.85	---	74.00	54.00	-5.15	Peak
6804.00	38.41	---	12.38	50.80	---	74.00	54.00	-3.20	Peak
7584.00	38.17	---	13.83	52.00	---	74.00	54.00	-2.00	Peak
966 Chamber_B at 3Meter / Vertical									
Frequency (MHz)	Reading-PK (dBuV)	Reading-AV (dBuV)	Correction Factor (dB/m)	Result-PK (dBuV/m)	Result-AV (dBuV/m)	Limit-PK (dBuV/m)	Limit-AV (dBuV/m)	Margin (dB)	Remark
1095.00	64.85	45.93	-4.26	60.59	41.67	74.00	54.00	-12.33	AVG
1255.00	54.19	---	-3.88	50.31	---	74.00	54.00	-3.69	Peak
1435.00	53.80	---	-3.45	50.35	---	74.00	54.00	-3.65	Peak
6144.00	37.35	---	11.49	48.84	---	74.00	54.00	-5.16	Peak
6768.00	38.06	---	12.39	50.45	---	74.00	54.00	-3.55	Peak
7620.00	38.20	---	13.81	52.01	---	74.00	54.00	-1.99	Peak

Remark:

1. Measuring frequencies from 1 GHz to the 10th harmonic of highest fundamental frequency.
2. Average test would be performed if the peak result were greater than the average limit.
3. Data of measurement within this frequency range shown " --- " in the table above means the reading of emissions are attenuated more than 20dB below the permissible limits or the field strength is too small to be measured.
4. Measurements above show only up to 6 maximum emissions noted, or would be lesser, with " N/A " remark, if no specific emissions from the EUT are recorded (ie: margin>20dB from the applicable limit) and considered that's already beyond the background noise floor.
5. Result = Reading + Correction Factor
Margin = Result - Limit
Remark Peak = Result(PK) - Limit(AV)
Remark AVG = Result(AV) - Limit(AV)



Product Name	Nuvola	Test By	Rueyyan Lin
Test Model	NP-1	Test Date	2013/11/06
Test Mode	IEEE 802.11an HT20 TX / CH Middle	Temp. & Humidity	25°C, 43%

966 Chamber_B at 3Meter / Horizontal									
Frequency (MHz)	Reading-PK (dBuV)	Reading-AV (dBuV)	Correction Factor (dB/m)	Result-PK (dBuV/m)	Result-AV (dBuV/m)	Limit-PK (dBuV/m)	Limit-AV (dBuV/m)	Margin (dB)	Remark
1060.00	55.04	---	-4.34	50.71	---	74.00	54.00	-3.29	Peak
1260.00	54.67	---	-3.87	50.81	---	74.00	54.00	-3.19	Peak
1475.00	54.16	---	-3.36	50.80	---	74.00	54.00	-3.20	Peak
1690.00	52.92	---	-1.20	51.72	---	74.00	54.00	-2.28	Peak
6384.00	37.32	---	12.15	49.47	---	74.00	54.00	-4.53	Peak
6912.00	37.96	---	12.35	50.31	---	74.00	54.00	-3.69	Peak
7752.00	37.92	---	13.72	51.64	---	74.00	54.00	-2.36	Peak

966 Chamber_B at 3Meter / Vertical									
Frequency (MHz)	Reading-PK (dBuV)	Reading-AV (dBuV)	Correction Factor (dB/m)	Result-PK (dBuV/m)	Result-AV (dBuV/m)	Limit-PK (dBuV/m)	Limit-AV (dBuV/m)	Margin (dB)	Remark
1120.00	55.13	---	-4.20	50.94	---	74.00	54.00	-3.06	Peak
1340.00	54.44	---	-3.68	50.77	---	74.00	54.00	-3.23	Peak
1550.00	53.33	---	-2.75	50.59	---	74.00	54.00	-3.41	Peak
1705.00	52.52	---	-1.04	51.48	---	74.00	54.00	-2.52	Peak
6108.00	37.16	---	11.40	48.56	---	74.00	54.00	-5.44	Peak
6744.00	37.78	---	12.40	50.18	---	74.00	54.00	-3.82	Peak
7620.00	37.87	---	13.81	51.68	---	74.00	54.00	-2.32	Peak

Remark:

1. Measuring frequencies from 1 GHz to the 10th harmonic of highest fundamental frequency.
2. Average test would be performed if the peak result were greater than the average limit.
3. Data of measurement within this frequency range shown " --- " in the table above means the reading of emissions are attenuated more than 20dB below the permissible limits or the field strength is too small to be measured.
4. Measurements above show only up to 6 maximum emissions noted, or would be lesser, with " N/A " remark, if no specific emissions from the EUT are recorded (ie: margin>20dB from the applicable limit) and considered that's already beyond the background noise floor.
5. Result = Reading + Correction Factor
Margin = Result - Limit
Remark Peak = Result(PK) - Limit(AV)
Remark AVG = Result(AV) - Limit(AV)



Product Name	Nuvola	Test By	Rueyyan Lin
Test Model	NP-1	Test Date	2013/11/06
Test Mode	IEEE 802.11an HT20 TX / CH High	Temp. & Humidity	25°C, 43%

966 Chamber_B at 3Meter / Horizontal									
Frequency (MHz)	Reading-PK (dBuV)	Reading-AV (dBuV)	Correction Factor (dB/m)	Result-PK (dBuV/m)	Result-AV (dBuV/m)	Limit-PK (dBuV/m)	Limit-AV (dBuV/m)	Margin (dB)	Remark
1035.00	55.01	---	-4.40	50.62	---	74.00	54.00	-3.38	Peak
1160.00	54.36	---	-4.10	50.26	---	74.00	54.00	-3.74	Peak
1390.00	54.05	---	-3.56	50.50	---	74.00	54.00	-3.50	Peak
1620.00	53.10	---	-1.98	51.12	---	74.00	54.00	-2.88	Peak
6204.00	36.81	---	11.66	48.47	---	74.00	54.00	-5.53	Peak
6720.00	37.23	---	12.41	49.64	---	74.00	54.00	-4.36	Peak
7716.00	38.07	---	13.75	51.82	---	74.00	54.00	-2.18	Peak

966 Chamber_B at 3Meter / Vertical									
Frequency (MHz)	Reading-PK (dBuV)	Reading-AV (dBuV)	Correction Factor (dB/m)	Result-PK (dBuV/m)	Result-AV (dBuV/m)	Limit-PK (dBuV/m)	Limit-AV (dBuV/m)	Margin (dB)	Remark
1030.00	54.70	---	-4.41	50.29	---	74.00	54.00	-3.71	Peak
1180.00	54.55	---	-4.06	50.50	---	74.00	54.00	-3.50	Peak
1405.00	54.58	---	-3.52	51.06	---	74.00	54.00	-2.94	Peak
1620.00	53.62	---	-1.98	51.65	---	74.00	54.00	-2.35	Peak
6216.00	37.68	---	11.69	49.37	---	74.00	54.00	-4.63	Peak
6828.00	38.06	---	12.38	50.44	---	74.00	54.00	-3.56	Peak
7656.00	37.89	---	13.78	51.67	---	74.00	54.00	-2.33	Peak

Remark:

1. Measuring frequencies from 1 GHz to the 10th harmonic of highest fundamental frequency.
2. Average test would be performed if the peak result were greater than the average limit.
3. Data of measurement within this frequency range shown " --- " in the table above means the reading of emissions are attenuated more than 20dB below the permissible limits or the field strength is too small to be measured.
4. Measurements above show only up to 6 maximum emissions noted, or would be lesser, with " N/A " remark, if no specific emissions from the EUT are recorded (ie: margin>20dB from the applicable limit) and considered that's already beyond the background noise floor.
5. Result = Reading + Correction Factor
Margin = Result - Limit
Remark Peak = Result(PK) - Limit(AV)
Remark AVG = Result(AV) - Limit(AV)



Product Name	Nuvola	Test By	Rueyyan Lin
Test Model	NP-1	Test Date	2013/11/06
Test Mode	IEEE 802.11an HT40 TX / CH Low	Temp. & Humidity	25°C, 43%

966 Chamber_B at 3Meter / Horizontal									
Frequency (MHz)	Reading-PK (dBuV)	Reading-AV (dBuV)	Correction Factor (dB/m)	Result-PK (dBuV/m)	Result-AV (dBuV/m)	Limit-PK (dBuV/m)	Limit-AV (dBuV/m)	Margin (dB)	Remark
1090.00	55.53	---	-4.27	51.26	---	74.00	54.00	-2.74	Peak
1235.00	54.02	---	-3.93	50.09	---	74.00	54.00	-3.91	Peak
1405.00	53.60	---	-3.52	50.08	---	74.00	54.00	-3.92	Peak
1665.00	53.45	---	-1.48	51.97	---	74.00	54.00	-2.03	Peak
6216.00	36.28	---	11.69	47.98	---	74.00	54.00	-6.02	Peak
6936.00	37.14	---	12.35	49.48	---	74.00	54.00	-4.52	Peak
7608.00	37.85	---	13.81	51.67	---	74.00	54.00	-2.33	Peak

966 Chamber_B at 3Meter / Vertical									
Frequency (MHz)	Reading-PK (dBuV)	Reading-AV (dBuV)	Correction Factor (dB/m)	Result-PK (dBuV/m)	Result-AV (dBuV/m)	Limit-PK (dBuV/m)	Limit-AV (dBuV/m)	Margin (dB)	Remark
1075.00	54.92	---	-4.30	50.62	---	74.00	54.00	-3.38	Peak
1320.00	54.48	---	-3.72	50.75	---	74.00	54.00	-3.25	Peak
1465.00	54.19	---	-3.38	50.81	---	74.00	54.00	-3.19	Peak
1665.00	53.13	---	-1.48	51.66	---	74.00	54.00	-2.34	Peak
6156.00	37.26	---	11.53	48.79	---	74.00	54.00	-5.21	Peak
6912.00	37.56	---	12.35	49.91	---	74.00	54.00	-4.09	Peak
7716.00	38.39	---	13.75	52.14	---	74.00	54.00	-1.86	Peak

Remark:

1. Measuring frequencies from 1 GHz to the 10th harmonic of highest fundamental frequency.
2. Average test would be performed if the peak result were greater than the average limit.
3. Data of measurement within this frequency range shown " --- " in the table above means the reading of emissions are attenuated more than 20dB below the permissible limits or the field strength is too small to be measured.
4. Measurements above show only up to 6 maximum emissions noted, or would be lesser, with " N/A " remark, if no specific emissions from the EUT are recorded (ie: margin>20dB from the applicable limit) and considered that's already beyond the background noise floor.
5. Result = Reading + Correction Factor
Margin = Result - Limit
Remark Peak = Result(PK) - Limit(AV)
Remark AVG = Result(AV) - Limit(AV)



Product Name	Nuvola	Test By	Rueyyan Lin
Test Model	NP-1	Test Date	2013/11/06
Test Mode	IEEE 802.11an HT40 TX / CH High	Temp. & Humidity	25°C, 43%

966 Chamber_B at 3Meter / Horizontal									
Frequency (MHz)	Reading-PK (dBuV)	Reading-AV (dBuV)	Correction Factor (dB/m)	Result-PK (dBuV/m)	Result-AV (dBuV/m)	Limit-PK (dBuV/m)	Limit-AV (dBuV/m)	Margin (dB)	Remark
1060.00	55.83	---	-4.34	51.49	---	74.00	54.00	-2.51	Peak
1205.00	54.24	---	-4.00	50.24	---	74.00	54.00	-3.76	Peak
1390.00	54.57	---	-3.56	51.01	---	74.00	54.00	-2.99	Peak
1635.00	53.11	---	-1.81	51.30	---	74.00	54.00	-2.70	Peak
6132.00	37.12	---	11.46	48.58	---	74.00	54.00	-5.42	Peak
6816.00	37.54	---	12.38	49.92	---	74.00	54.00	-4.08	Peak
7776.00	37.98	---	13.71	51.69	---	74.00	54.00	-2.31	Peak

966 Chamber_B at 3Meter / Vertical									
Frequency (MHz)	Reading-PK (dBuV)	Reading-AV (dBuV)	Correction Factor (dB/m)	Result-PK (dBuV/m)	Result-AV (dBuV/m)	Limit-PK (dBuV/m)	Limit-AV (dBuV/m)	Margin (dB)	Remark
1010.00	54.55	---	-4.46	50.10	---	74.00	54.00	-3.90	Peak
1250.00	54.34	---	-3.89	50.45	---	74.00	54.00	-3.55	Peak
1465.00	54.18	---	-3.38	50.80	---	74.00	54.00	-3.20	Peak
1635.00	53.51	---	-1.81	51.71	---	74.00	54.00	-2.29	Peak
6264.00	37.11	---	11.82	48.94	---	74.00	54.00	-5.06	Peak
6756.00	38.61	---	12.40	51.01	---	74.00	54.00	-2.99	Peak
7752.00	38.72	---	13.72	52.45	---	74.00	54.00	-1.55	Peak

Remark:

1. Measuring frequencies from 1 GHz to the 10th harmonic of highest fundamental frequency.
2. Average test would be performed if the peak result were greater than the average limit.
3. Data of measurement within this frequency range shown " --- " in the table above means the reading of emissions are attenuated more than 20dB below the permissible limits or the field strength is too small to be measured.
4. Measurements above show only up to 6 maximum emissions noted, or would be lesser, with " N/A " remark, if no specific emissions from the EUT are recorded (ie: margin>20dB from the applicable limit) and considered that's already beyond the background noise floor.
5. Result = Reading + Correction Factor
Margin = Result – Limit
Remark Peak = Result(PK) – Limit(AV)
Remark AVG = Result(AV) – Limit(AV)



Product Name	Nuvola	Test By	Rueyyan Lin
Test Model	NP-1	Test Date	2013/11/09
Test Mode	IEEE 802.11b TX / CH Low	Temp. & Humidity	26°C, 48%

966 Chamber_B at 3Meter / Horizontal									
Frequency (MHz)	Reading-PK (dBuV)	Reading-AV (dBuV)	Correction Factor (dB/m)	Result-PK (dBuV/m)	Result-AV (dBuV/m)	Limit-PK (dBuV/m)	Limit-AV (dBuV/m)	Margin (dB)	Remark
1030.00	55.24	---	-4.41	50.83	---	74.00	54.00	-3.17	Peak
1168.00	54.76	---	-4.08	50.67	---	74.00	54.00	-3.33	Peak
1330.00	54.84	---	-3.70	51.13	---	74.00	54.00	-2.87	Peak
1464.00	54.66	---	-3.38	51.27	---	74.00	54.00	-2.73	Peak
2390.00	59.67	50.56	2.91	62.58	53.47	74.00	54.00	-0.53	AVG
3225.00	41.69	---	4.96	46.65	---	74.00	54.00	-7.35	Peak
4005.00	40.89	---	6.77	47.66	---	74.00	54.00	-6.34	Peak
4830.00	47.98	45.13	8.75	56.73	53.88	74.00	54.00	-0.12	AVG

966 Chamber_B at 3Meter / Vertical									
Frequency (MHz)	Reading-PK (dBuV)	Reading-AV (dBuV)	Correction Factor (dB/m)	Result-PK (dBuV/m)	Result-AV (dBuV/m)	Limit-PK (dBuV/m)	Limit-AV (dBuV/m)	Margin (dB)	Remark
1006.00	55.20	---	-4.47	50.73	---	74.00	54.00	-3.27	Peak
1234.00	54.81	---	-3.93	50.88	---	74.00	54.00	-3.12	Peak
1474.00	54.01	---	-3.36	50.65	---	74.00	54.00	-3.35	Peak
1886.00	55.35	40.21	0.96	56.31	41.17	74.00	54.00	-12.83	AVG
2390.00	55.86	43.77	2.91	58.77	46.68	74.00	54.00	-7.32	AVG
3720.00	43.94	---	5.88	49.82	---	74.00	54.00	-4.18	Peak
4305.00	41.75	---	7.40	49.15	---	74.00	54.00	-4.85	Peak
4830.00	47.99	44.95	8.75	56.74	53.70	74.00	54.00	-0.30	AVG

Remark:

1. Measuring frequencies from 1 GHz to the 10th harmonic of highest fundamental frequency.
2. Average test would be performed if the peak result were greater than the average limit.
3. Data of measurement within this frequency range shown " --- " in the table above means the reading of emissions are attenuated more than 20dB below the permissible limits or the field strength is too small to be measured.
4. Measurements above show only up to 6 maximum emissions noted, or would be lesser, with " N/A " remark, if no specific emissions from the EUT are recorded (ie: margin>20dB from the applicable limit) and considered that's already beyond the background noise floor.
5. Result = Reading + Correction Factor
Margin = Result - Limit
Remark Peak = Result(PK) - Limit(AV)
Remark AVG = Result(AV) - Limit(AV)



Product Name	Nuvola	Test By	Rueyyan Lin
Test Model	NP-1	Test Date	2013/11/09
Test Mode	IEEE 802.11b TX / CH Middle	Temp. & Humidity	26°C, 48%

966 Chamber_B at 3Meter / Horizontal									
Frequency (MHz)	Reading-PK (dBuV)	Reading-AV (dBuV)	Correction Factor (dB/m)	Result-PK (dBuV/m)	Result-AV (dBuV/m)	Limit-PK (dBuV/m)	Limit-AV (dBuV/m)	Margin (dB)	Remark
1020.00	55.06	---	-4.43	50.63	---	74.00	54.00	-3.37	Peak
1156.00	54.86	---	-4.11	50.75	---	74.00	54.00	-3.25	Peak
1350.00	54.63	---	-3.65	50.98	---	74.00	54.00	-3.02	Peak
1520.00	53.76	---	-3.08	50.68	---	74.00	54.00	-3.32	Peak
3225.00	41.08	---	4.96	46.05	---	74.00	54.00	-7.95	Peak
3945.00	39.93	---	6.59	46.51	---	74.00	54.00	-7.49	Peak
4875.00	48.16	44.13	8.88	57.04	53.01	74.00	54.00	-0.99	AVG

966 Chamber_B at 3Meter / Vertical									
Frequency (MHz)	Reading-PK (dBuV)	Reading-AV (dBuV)	Correction Factor (dB/m)	Result-PK (dBuV/m)	Result-AV (dBuV/m)	Limit-PK (dBuV/m)	Limit-AV (dBuV/m)	Margin (dB)	Remark
1016.00	55.05	---	-4.44	50.61	---	74.00	54.00	-3.39	Peak
1186.00	54.36	---	-4.04	50.32	---	74.00	54.00	-3.68	Peak
1336.00	54.98	---	-3.69	51.29	---	74.00	54.00	-2.71	Peak
1488.00	54.49	---	-3.33	51.16	---	74.00	54.00	-2.84	Peak
3277.50	41.89	---	5.01	46.90	---	74.00	54.00	-7.10	Peak
3862.50	41.85	---	6.33	48.18	---	74.00	54.00	-5.82	Peak
4305.00	41.78	---	7.40	49.19	---	74.00	54.00	-4.81	Peak
4875.00	48.22	44.83	8.88	57.10	53.71	74.00	54.00	-0.29	AVG

Remark:

1. Measuring frequencies from 1 GHz to the 10th harmonic of highest fundamental frequency.
2. Average test would be performed if the peak result were greater than the average limit.
3. Data of measurement within this frequency range shown " --- " in the table above means the reading of emissions are attenuated more than 20dB below the permissible limits or the field strength is too small to be measured.
4. Measurements above show only up to 6 maximum emissions noted, or would be lesser, with " N/A " remark, if no specific emissions from the EUT are recorded (ie: margin>20dB from the applicable limit) and considered that's already beyond the background noise floor.
5. Result = Reading + Correction Factor
Margin = Result - Limit
Remark Peak = Result(PK) - Limit(AV)
Remark AVG = Result(AV) - Limit(AV)



Product Name	Nuvola	Test By	Rueyyan Lin
Test Model	NP-1	Test Date	2013/11/09
Test Mode	IEEE 802.11b TX / CH High	Temp. & Humidity	26°C, 48%

966 Chamber_B at 3Meter / Horizontal									
Frequency (MHz)	Reading-PK (dBuV)	Reading-AV (dBuV)	Correction Factor (dB/m)	Result-PK (dBuV/m)	Result-AV (dBuV/m)	Limit-PK (dBuV/m)	Limit-AV (dBuV/m)	Margin (dB)	Remark
1028.00	54.34	---	-4.41	49.93	---	74.00	54.00	-4.07	Peak
1254.00	55.14	---	-3.88	51.26	---	74.00	54.00	-2.74	Peak
1458.00	54.05	---	-3.40	50.65	---	74.00	54.00	-3.35	Peak
1638.00	53.43	---	-1.78	51.66	---	74.00	54.00	-2.34	Peak
2483.50	57.78	50.73	3.08	60.86	53.81	74.00	54.00	-0.19	AVG
3232.50	42.28	---	4.97	47.25	---	74.00	54.00	-6.75	Peak
4297.50	40.72	---	7.38	48.10	---	74.00	54.00	-5.90	Peak
4927.50	46.63	41.80	9.03	55.66	50.83	74.00	54.00	-3.17	AVG

966 Chamber_B at 3Meter / Vertical									
Frequency (MHz)	Reading-PK (dBuV)	Reading-AV (dBuV)	Correction Factor (dB/m)	Result-PK (dBuV/m)	Result-AV (dBuV/m)	Limit-PK (dBuV/m)	Limit-AV (dBuV/m)	Margin (dB)	Remark
1046.00	54.74	---	-4.37	50.37	---	74.00	54.00	-3.63	Peak
1202.00	55.23	---	-4.00	51.23	---	74.00	54.00	-2.77	Peak
1404.00	53.93	---	-3.53	50.40	---	74.00	54.00	-3.60	Peak
1602.00	57.63	41.63	-2.17	55.46	39.46	74.00	54.00	-14.54	AVG
2483.50	56.25	46.42	3.08	59.33	49.50	74.00	54.00	-4.50	AVG
3705.00	43.16	---	5.83	49.00	---	74.00	54.00	-5.00	Peak
4305.00	40.83	---	7.40	48.23	---	74.00	54.00	-5.77	Peak
4920.00	47.92	43.73	9.01	56.93	52.74	74.00	54.00	-1.26	AVG

Remark:

1. Measuring frequencies from 1 GHz to the 10th harmonic of highest fundamental frequency.
2. Average test would be performed if the peak result were greater than the average limit.
3. Data of measurement within this frequency range shown " --- " in the table above means the reading of emissions are attenuated more than 20dB below the permissible limits or the field strength is too small to be measured.
4. Measurements above show only up to 6 maximum emissions noted, or would be lesser, with " N/A " remark, if no specific emissions from the EUT are recorded (ie: margin>20dB from the applicable limit) and considered that's already beyond the background noise floor.
5. Result = Reading + Correction Factor
Margin = Result - Limit
Remark Peak = Result(PK) - Limit(AV)
Remark AVG = Result(AV) - Limit(AV)



Product Name	Nuvola	Test By	Rueyyan Lin
Test Model	NP-1	Test Date	2013/11/07
Test Mode	IEEE 802.11g TX / CH Low	Temp. & Humidity	26°C, 46%

966 Chamber_B at 3Meter / Horizontal									
Frequency (MHz)	Reading-PK (dBuV)	Reading-AV (dBuV)	Correction Factor (dB/m)	Result-PK (dBuV/m)	Result-AV (dBuV/m)	Limit-PK (dBuV/m)	Limit-AV (dBuV/m)	Margin (dB)	Remark
1026.00	55.22	---	-4.42	50.80	---	74.00	54.00	-3.20	Peak
1212.00	54.61	---	-3.98	50.63	---	74.00	54.00	-3.37	Peak
1410.00	53.97	---	-3.51	50.46	---	74.00	54.00	-3.54	Peak
2390.00	70.33	46.64	2.91	73.24	49.55	74.00	54.00	-0.76	AVG
3180.00	41.62	---	4.93	46.55	---	74.00	54.00	-7.45	Peak
4005.00	39.88	---	6.77	46.65	---	74.00	54.00	-7.35	Peak
4830.00	39.01	---	8.75	47.76	---	74.00	54.00	-6.24	Peak

966 Chamber_B at 3Meter / Vertical									
Frequency (MHz)	Reading-PK (dBuV)	Reading-AV (dBuV)	Correction Factor (dB/m)	Result-PK (dBuV/m)	Result-AV (dBuV/m)	Limit-PK (dBuV/m)	Limit-AV (dBuV/m)	Margin (dB)	Remark
1064.00	54.73	---	-4.33	50.40	---	74.00	54.00	-3.60	Peak
1266.00	54.30	---	-3.85	50.45	---	74.00	54.00	-3.55	Peak
1444.00	53.75	---	-3.43	50.32	---	74.00	54.00	-3.68	Peak
2390.00	63.24	41.82	2.91	66.15	44.73	74.00	54.00	-7.85	AVG
3180.00	41.65	---	4.93	46.58	---	74.00	54.00	-7.42	Peak
3855.00	44.23	---	6.30	50.54	---	74.00	54.00	-3.46	Peak
4305.00	42.47	---	7.40	49.87	---	74.00	54.00	-4.13	Peak
4830.00	37.87	---	8.75	46.63	---	74.00	54.00	-7.37	Peak

Remark:

1. Measuring frequencies from 1 GHz to the 10th harmonic of highest fundamental frequency.
2. Average test would be performed if the peak result were greater than the average limit.
3. Data of measurement within this frequency range shown " --- " in the table above means the reading of emissions are attenuated more than 20dB below the permissible limits or the field strength is too small to be measured.
4. Measurements above show only up to 6 maximum emissions noted, or would be lesser, with " N/A " remark, if no specific emissions from the EUT are recorded (ie: margin>20dB from the applicable limit) and considered that's already beyond the background noise floor.
5. Result = Reading + Correction Factor
Margin = Result - Limit
Remark Peak = Result(PK) - Limit(AV)
Remark AVG = Result(AV) - Limit(AV)



Product Name	Nuvola	Test By	Rueyyan Lin
Test Model	NP-1	Test Date	2013/11/07
Test Mode	IEEE 802.11g TX / CH Middle	Temp. & Humidity	26°C, 46%

966 Chamber_B at 3Meter / Horizontal									
Frequency (MHz)	Reading-PK (dBuV)	Reading-AV (dBuV)	Correction Factor (dB/m)	Result-PK (dBuV/m)	Result-AV (dBuV/m)	Limit-PK (dBuV/m)	Limit-AV (dBuV/m)	Margin (dB)	Remark
1044.00	55.34	---	-4.38	50.96	---	74.00	54.00	-3.04	Peak
1220.00	54.92	---	-3.96	50.96	---	74.00	54.00	-3.04	Peak
1354.00	53.78	---	-3.64	50.14	---	74.00	54.00	-3.86	Peak
2390.00	70.97	47.63	2.91	73.88	50.54	74.00	54.00	-0.12	AVG
2483.50	69.76	47.55	3.08	72.84	50.63	74.00	54.00	-1.16	AVG
3225.00	42.46	---	4.96	47.42	---	74.00	54.00	-6.58	Peak
4005.00	39.86	---	6.77	46.63	---	74.00	54.00	-7.37	Peak
4425.00	39.69	---	7.65	47.34	---	74.00	54.00	-6.66	Peak
4875.00	48.26	33.95	8.88	57.14	42.83	74.00	54.00	-11.17	AVG

966 Chamber_B at 3Meter / Vertical									
Frequency (MHz)	Reading-PK (dBuV)	Reading-AV (dBuV)	Correction Factor (dB/m)	Result-PK (dBuV/m)	Result-AV (dBuV/m)	Limit-PK (dBuV/m)	Limit-AV (dBuV/m)	Margin (dB)	Remark
1026.00	55.48	---	-4.42	51.06	---	74.00	54.00	-2.94	Peak
1172.00	55.00	---	-4.07	50.93	---	74.00	54.00	-3.07	Peak
1336.00	53.93	---	-3.69	50.24	---	74.00	54.00	-3.76	Peak
2390.00	61.19	42.43	2.91	64.10	45.34	74.00	54.00	-8.66	AVG
2483.50	63.68	43.51	3.08	66.76	46.59	74.00	54.00	-7.24	AVG
3720.00	43.88	---	5.88	49.76	---	74.00	54.00	-4.24	Peak
3855.00	43.90	---	6.30	50.21	---	74.00	54.00	-3.79	Peak
4305.00	43.15	---	7.40	50.55	---	74.00	54.00	-3.45	Peak
4875.00	49.23	35.50	8.88	58.11	44.38	74.00	54.00	-9.62	AVG

Remark:

1. Measuring frequencies from 1 GHz to the 10th harmonic of highest fundamental frequency.
2. Average test would be performed if the peak result were greater than the average limit.
3. Data of measurement within this frequency range shown " --- " in the table above means the reading of emissions are attenuated more than 20dB below the permissible limits or the field strength is too small to be measured.
4. Measurements above show only up to 6 maximum emissions noted, or would be lesser, with " N/A " remark, if no specific emissions from the EUT are recorded (ie: margin>20dB from the applicable limit) and considered that's already beyond the background noise floor.
5. Result = Reading + Correction Factor
Margin = Result - Limit
Remark Peak = Result(PK) - Limit(AV)
Remark AVG = Result(AV) - Limit(AV)



Product Name	Nuvola	Test By	Rueyyan Lin
Test Model	NP-1	Test Date	2013/11/07
Test Mode	IEEE 802.11g TX / CH High	Temp. & Humidity	26°C, 46%

966 Chamber_B at 3Meter / Horizontal									
Frequency (MHz)	Reading-PK (dBuV)	Reading-AV (dBuV)	Correction Factor (dB/m)	Result-PK (dBuV/m)	Result-AV (dBuV/m)	Limit-PK (dBuV/m)	Limit-AV (dBuV/m)	Margin (dB)	Remark
1016.00	55.05	---	-4.44	50.60	---	74.00	54.00	-3.40	Peak
1186.00	55.04	---	-4.04	51.00	---	74.00	54.00	-3.00	Peak
1306.00	54.54	---	-3.76	50.78	---	74.00	54.00	-3.22	Peak
2483.50	70.17	44.73	3.08	73.25	47.81	74.00	54.00	-0.75	AVG
3240.00	41.61	---	4.98	46.59	---	74.00	54.00	-7.41	Peak
3855.00	40.32	---	6.30	46.62	---	74.00	54.00	-7.38	Peak
4290.00	39.91	---	7.37	47.28	---	74.00	54.00	-6.72	Peak
4935.00	38.68	---	9.05	47.73	---	74.00	54.00	-6.27	Peak

966 Chamber_B at 3Meter / Vertical									
Frequency (MHz)	Reading-PK (dBuV)	Reading-AV (dBuV)	Correction Factor (dB/m)	Result-PK (dBuV/m)	Result-AV (dBuV/m)	Limit-PK (dBuV/m)	Limit-AV (dBuV/m)	Margin (dB)	Remark
1016.00	55.25	---	-4.44	50.81	---	74.00	54.00	-3.19	Peak
1138.00	54.90	---	-4.15	50.74	---	74.00	54.00	-3.26	Peak
1340.00	54.43	---	-3.68	50.75	---	74.00	54.00	-3.25	Peak
2484.00	64.62	41.72	3.08	67.70	44.80	74.00	54.00	-6.30	AVG
3705.00	43.28	---	5.83	49.11	---	74.00	54.00	-4.89	Peak
4005.00	42.94	---	6.77	49.71	---	74.00	54.00	-4.29	Peak
4305.00	42.36	---	7.40	49.77	---	74.00	54.00	-4.23	Peak
4890.00	39.57	---	8.93	48.50	---	74.00	54.00	-5.50	Peak

Remark:

1. Measuring frequencies from 1 GHz to the 10th harmonic of highest fundamental frequency.
2. Average test would be performed if the peak result were greater than the average limit.
3. Data of measurement within this frequency range shown " --- " in the table above means the reading of emissions are attenuated more than 20dB below the permissible limits or the field strength is too small to be measured.
4. Measurements above show only up to 6 maximum emissions noted, or would be lesser, with " N/A " remark, if no specific emissions from the EUT are recorded (ie: margin>20dB from the applicable limit) and considered that's already beyond the background noise floor.
5. Result = Reading + Correction Factor
Margin = Result - Limit
Remark Peak = Result(PK) - Limit(AV)
Remark AVG = Result(AV) - Limit(AV)



Product Name	Nuvola	Test By	Rueyyan Lin
Test Model	NP-1	Test Date	2013/11/07
Test Mode	IEEE 802.11n HT20 TX / CH Low	Temp. & Humidity	26°C, 46%

966 Chamber_B at 3Meter / Horizontal									
Frequency (MHz)	Reading-PK (dBuV)	Reading-AV (dBuV)	Correction Factor (dB/m)	Result-PK (dBuV/m)	Result-AV (dBuV/m)	Limit-PK (dBuV/m)	Limit-AV (dBuV/m)	Margin (dB)	Remark
1014.00	54.75	---	-4.45	50.30	---	74.00	54.00	-3.70	Peak
1158.00	55.42	---	-4.11	51.31	---	74.00	54.00	-2.69	Peak
1338.00	54.07	---	-3.68	50.38	---	74.00	54.00	-3.62	Peak
2390.00	70.15	47.71	2.91	73.06	50.62	74.00	54.00	-0.94	AVG
3195.00	42.54	---	4.94	47.48	---	74.00	54.00	-6.52	Peak
4005.00	40.03	---	6.77	46.80	---	74.00	54.00	-7.20	Peak
4830.00	38.09	---	8.75	46.84	---	74.00	54.00	-7.16	Peak

966 Chamber_B at 3Meter / Vertical									
Frequency (MHz)	Reading-PK (dBuV)	Reading-AV (dBuV)	Correction Factor (dB/m)	Result-PK (dBuV/m)	Result-AV (dBuV/m)	Limit-PK (dBuV/m)	Limit-AV (dBuV/m)	Margin (dB)	Remark
1064.00	55.59	---	-4.33	51.26	---	74.00	54.00	-2.74	Peak
1226.00	54.21	---	-3.95	50.27	---	74.00	54.00	-3.73	Peak
1342.00	54.26	---	-3.67	50.59	---	74.00	54.00	-3.41	Peak
2390.00	65.18	43.43	2.91	68.09	46.34	74.00	54.00	-5.91	AVG
3315.00	41.59	---	5.04	46.63	---	74.00	54.00	-7.37	Peak
3720.00	41.14	---	5.88	47.02	---	74.00	54.00	-6.98	Peak
4305.00	42.96	---	7.40	50.36	---	74.00	54.00	-3.64	Peak
4830.00	38.78	---	8.75	47.54	---	74.00	54.00	-6.46	Peak

Remark:

1. Measuring frequencies from 1 GHz to the 10th harmonic of highest fundamental frequency.
2. Average test would be performed if the peak result were greater than the average limit.
3. Data of measurement within this frequency range shown " --- " in the table above means the reading of emissions are attenuated more than 20dB below the permissible limits or the field strength is too small to be measured.
4. Measurements above show only up to 6 maximum emissions noted, or would be lesser, with " N/A " remark, if no specific emissions from the EUT are recorded (ie: margin>20dB from the applicable limit) and considered that's already beyond the background noise floor.
5. Result = Reading + Correction Factor
Margin = Result - Limit
Remark Peak = Result(PK) - Limit(AV)
Remark AVG = Result(AV) - Limit(AV)



Product Name	Nuvola	Test By	Rueyyan Lin
Test Model	NP-1	Test Date	2013/11/07
Test Mode	IEEE 802.11n HT20 TX / CH Middle	Temp. & Humidity	26°C, 46%

966 Chamber_B at 3Meter / Horizontal									
Frequency (MHz)	Reading-PK (dBuV)	Reading-AV (dBuV)	Correction Factor (dB/m)	Result-PK (dBuV/m)	Result-AV (dBuV/m)	Limit-PK (dBuV/m)	Limit-AV (dBuV/m)	Margin (dB)	Remark
1090.00	54.61	---	-4.27	50.34	---	74.00	54.00	-3.66	Peak
1248.00	54.08	---	-3.89	50.18	---	74.00	54.00	-3.82	Peak
1362.00	54.27	---	-3.63	50.64	---	74.00	54.00	-3.36	Peak
2390.00	70.10	47.86	2.91	73.01	50.77	74.00	54.00	-0.99	AVG
2483.50	68.60	46.92	3.08	71.68	50.00	74.00	54.00	-2.32	AVG
3225.00	41.54	---	4.96	46.50	---	74.00	54.00	-7.50	Peak
3915.00	40.70	---	6.49	47.19	---	74.00	54.00	-6.81	Peak
4875.00	41.33	---	8.88	50.21	---	74.00	54.00	-3.79	Peak

966 Chamber_B at 3Meter / Vertical									
Frequency (MHz)	Reading-PK (dBuV)	Reading-AV (dBuV)	Correction Factor (dB/m)	Result-PK (dBuV/m)	Result-AV (dBuV/m)	Limit-PK (dBuV/m)	Limit-AV (dBuV/m)	Margin (dB)	Remark
1034.00	55.38	---	-4.40	50.98	---	74.00	54.00	-3.02	Peak
1218.00	54.08	---	-3.97	50.11	---	74.00	54.00	-3.89	Peak
1362.00	53.37	---	-3.63	49.74	---	74.00	54.00	-4.26	Peak
2390.00	64.31	44.26	2.91	67.22	47.17	74.00	54.00	-6.78	AVG
2483.50	64.18	44.24	3.08	67.26	47.32	74.00	54.00	-6.68	AVG
3225.00	40.62	---	4.96	45.59	---	74.00	54.00	-8.41	Peak
3720.00	42.04	---	5.88	47.92	---	74.00	54.00	-6.08	Peak
4305.00	40.75	---	7.40	48.15	---	74.00	54.00	-5.85	Peak
4890.00	46.70	32.78	8.93	55.63	41.71	74.00	54.00	-12.29	AVG

Remark:

1. Measuring frequencies from 1 GHz to the 10th harmonic of highest fundamental frequency.
2. Average test would be performed if the peak result were greater than the average limit.
3. Data of measurement within this frequency range shown " --- " in the table above means the reading of emissions are attenuated more than 20dB below the permissible limits or the field strength is too small to be measured.
4. Measurements above show only up to 6 maximum emissions noted, or would be lesser, with " N/A " remark, if no specific emissions from the EUT are recorded (ie: margin>20dB from the applicable limit) and considered that's already beyond the background noise floor.
5. Result = Reading + Correction Factor
Margin = Result - Limit
Remark Peak = Result(PK) - Limit(AV)
Remark AVG = Result(AV) - Limit(AV)



Product Name	Nuvola	Test By	Rueyyan Lin
Test Model	NP-1	Test Date	2013/11/07
Test Mode	IEEE 802.11n HT20 TX / CH High	Temp. & Humidity	26°C, 46%

966 Chamber_B at 3Meter / Horizontal									
Frequency (MHz)	Reading-PK (dBuV)	Reading-AV (dBuV)	Correction Factor (dB/m)	Result-PK (dBuV/m)	Result-AV (dBuV/m)	Limit-PK (dBuV/m)	Limit-AV (dBuV/m)	Margin (dB)	Remark
1034.00	55.33	---	-4.40	50.93	---	74.00	54.00	-3.07	Peak
1170.00	55.56	---	-4.08	51.48	---	74.00	54.00	-2.52	Peak
1282.00	54.68	---	-3.81	50.86	---	74.00	54.00	-3.14	Peak
2483.50	70.47	45.01	3.08	73.55	48.09	74.00	54.00	-0.45	AVG
3120.00	41.62	---	4.88	46.50	---	74.00	54.00	-7.50	Peak
3945.00	40.31	---	6.59	46.90	---	74.00	54.00	-7.10	Peak
4920.00	38.93	---	9.01	47.94	---	74.00	54.00	-6.06	Peak

966 Chamber_B at 3Meter / Vertical									
Frequency (MHz)	Reading-PK (dBuV)	Reading-AV (dBuV)	Correction Factor (dB/m)	Result-PK (dBuV/m)	Result-AV (dBuV/m)	Limit-PK (dBuV/m)	Limit-AV (dBuV/m)	Margin (dB)	Remark
1044.00	55.12	---	-4.38	50.74	---	74.00	54.00	-3.26	Peak
1190.00	54.23	---	-4.03	50.20	---	74.00	54.00	-3.80	Peak
1346.00	54.60	---	-3.66	50.94	---	74.00	54.00	-3.06	Peak
2483.50	70.17	42.72	3.08	73.25	45.80	74.00	54.00	-0.75	AVG
3720.00	42.17	---	5.88	48.05	---	74.00	54.00	-5.95	Peak
3855.00	41.93	---	6.30	48.24	---	74.00	54.00	-5.76	Peak
4305.00	42.61	---	7.40	50.01	---	74.00	54.00	-3.99	Peak
4935.00	39.03	---	9.05	48.08	---	74.00	54.00	-5.92	Peak

Remark:

1. Measuring frequencies from 1 GHz to the 10th harmonic of highest fundamental frequency.
2. Average test would be performed if the peak result were greater than the average limit.
3. Data of measurement within this frequency range shown " --- " in the table above means the reading of emissions are attenuated more than 20dB below the permissible limits or the field strength is too small to be measured.
4. Measurements above show only up to 6 maximum emissions noted, or would be lesser, with " N/A " remark, if no specific emissions from the EUT are recorded (ie: margin>20dB from the applicable limit) and considered that's already beyond the background noise floor.
5. Result = Reading + Correction Factor
Margin = Result - Limit
Remark Peak = Result(PK) - Limit(AV)
Remark AVG = Result(AV) - Limit(AV)



Product Name	Nuvola	Test By	Rueyyan Lin
Test Model	NP-1	Test Date	2013/11/09
Test Mode	Bluetooth 4.0 / TX Mode /CH Low	Temp. & Humidity	26°C, 48%

966 Chamber_B at 3Meter / Horizontal									
Frequency (MHz)	Reading-PK (dBuV)	Reading-AV (dBuV)	Correction Factor (dB/m)	Result-PK (dBuV/m)	Result-AV (dBuV/m)	Limit-PK (dBuV/m)	Limit-AV (dBuV/m)	Margin (dB)	Remark
1024.00	54.92	---	-4.42	50.49	---	74.00	54.00	-3.51	Peak
1228.00	55.20	---	-3.94	51.25	---	74.00	54.00	-2.75	Peak
1426.00	52.99	---	-3.47	49.51	---	74.00	54.00	-4.49	Peak
1610.00	53.29	---	-2.09	51.20	---	74.00	54.00	-2.80	Peak
3255.00	41.31	---	4.99	46.30	---	74.00	54.00	-7.70	Peak
4005.00	41.52	---	6.77	48.29	---	74.00	54.00	-5.71	Peak
4845.00	38.29	---	8.80	47.09	---	74.00	54.00	-6.91	Peak

966 Chamber_B at 3Meter / Vertical									
Frequency (MHz)	Reading-PK (dBuV)	Reading-AV (dBuV)	Correction Factor (dB/m)	Result-PK (dBuV/m)	Result-AV (dBuV/m)	Limit-PK (dBuV/m)	Limit-AV (dBuV/m)	Margin (dB)	Remark
1016.00	55.01	---	-4.44	50.57	---	74.00	54.00	-3.43	Peak
1152.00	53.59	---	-4.12	49.47	---	74.00	54.00	-4.53	Peak
1330.00	54.05	---	-3.70	50.35	---	74.00	54.00	-3.65	Peak
1602.00	53.08	---	-2.17	50.91	---	74.00	54.00	-3.09	Peak
3180.00	42.15	---	4.93	47.07	---	74.00	54.00	-6.93	Peak
3720.00	43.92	---	5.88	49.80	---	74.00	54.00	-4.20	Peak
3855.00	43.64	---	6.30	49.95	---	74.00	54.00	-4.05	Peak
4800.00	38.70	---	8.67	47.37	---	74.00	54.00	-6.63	Peak

Remark:

1. Measuring frequencies from 1 GHz to the 10th harmonic of highest fundamental frequency.
2. Average test would be performed if the peak result were greater than the average limit.
3. Data of measurement within this frequency range shown " --- " in the table above means the reading of emissions are attenuated more than 20dB below the permissible limits or the field strength is too small to be measured.
4. Measurements above show only up to 6 maximum emissions noted, or would be lesser, with " N/A " remark, if no specific emissions from the EUT are recorded (ie: margin>20dB from the applicable limit) and considered that's already beyond the background noise floor.
5. Result = Reading + Correction Factor
Margin = Result - Limit
Remark Peak = Result(PK) - Limit(AV)
Remark AVG = Result(AV) - Limit(AV)



Product Name	Nuvola	Test By	Rueyyan Lin
Test Model	NP-1	Test Date	2013/11/09
Test Mode	Bluetooth 4.0 / TX Mode / CH Middle	Temp. & Humidity	26°C, 48%

966 Chamber_B at 3Meter / Horizontal									
Frequency (MHz)	Reading-PK (dBuV)	Reading-AV (dBuV)	Correction Factor (dB/m)	Result-PK (dBuV/m)	Result-AV (dBuV/m)	Limit-PK (dBuV/m)	Limit-AV (dBuV/m)	Margin (dB)	Remark
1026.00	53.95	---	-4.42	49.53	---	74.00	54.00	-4.47	Peak
1174.00	54.27	---	-4.07	50.20	---	74.00	54.00	-3.80	Peak
1368.00	53.84	---	-3.61	50.23	---	74.00	54.00	-3.77	Peak
1704.00	52.70	---	-1.05	51.65	---	74.00	54.00	-2.35	Peak
3270.00	41.99	---	5.00	47.00	---	74.00	54.00	-7.00	Peak
4005.00	41.22	---	6.77	47.99	---	74.00	54.00	-6.01	Peak
4305.00	39.66	---	7.40	47.06	---	74.00	54.00	-6.94	Peak
4890.00	38.41	---	8.93	47.34	---	74.00	54.00	-6.66	Peak

966 Chamber_B at 3Meter / Vertical									
Frequency (MHz)	Reading-PK (dBuV)	Reading-AV (dBuV)	Correction Factor (dB/m)	Result-PK (dBuV/m)	Result-AV (dBuV/m)	Limit-PK (dBuV/m)	Limit-AV (dBuV/m)	Margin (dB)	Remark
1036.00	54.25	---	-4.40	49.85	---	74.00	54.00	-4.15	Peak
1246.00	54.47	---	-3.90	50.57	---	74.00	54.00	-3.43	Peak
1438.00	53.94	---	-3.45	50.49	---	74.00	54.00	-3.51	Peak
1634.00	52.79	---	-1.82	50.97	---	74.00	54.00	-3.03	Peak
3270.00	43.60	---	5.00	48.60	---	74.00	54.00	-5.40	Peak
3720.00	44.73	---	5.88	50.62	---	74.00	54.00	-3.38	Peak
3855.00	44.04	---	6.30	50.34	---	74.00	54.00	-3.66	Peak
4890.00	38.79	---	8.93	47.71	---	74.00	54.00	-6.29	Peak

Remark:

1. Measuring frequencies from 1 GHz to the 10th harmonic of highest fundamental frequency.
2. Average test would be performed if the peak result were greater than the average limit.
3. Data of measurement within this frequency range shown " --- " in the table above means the reading of emissions are attenuated more than 20dB below the permissible limits or the field strength is too small to be measured.
4. Measurements above show only up to 6 maximum emissions noted, or would be lesser, with " N/A " remark, if no specific emissions from the EUT are recorded (ie: margin>20dB from the applicable limit) and considered that's already beyond the background noise floor.
5. Result = Reading + Correction Factor
Margin = Result - Limit
Remark Peak = Result(PK) - Limit(AV)
Remark AVG = Result(AV) - Limit(AV)



Product Name	Nuvola	Test By	Rueyyan Lin
Test Model	NP-1	Test Date	2013/11/09
Test Mode	Bluetooth 4.0 / TX Mode / CH High	Temp. & Humidity	26°C, 48%

966 Chamber_B at 3Meter / Horizontal									
Frequency (MHz)	Reading-PK (dBuV)	Reading-AV (dBuV)	Correction Factor (dB/m)	Result-PK (dBuV/m)	Result-AV (dBuV/m)	Limit-PK (dBuV/m)	Limit-AV (dBuV/m)	Margin (dB)	Remark
1016.00	54.60	---	-4.44	50.16	---	74.00	54.00	-3.84	Peak
1186.00	55.47	---	-4.04	51.43	---	74.00	54.00	-2.57	Peak
1370.00	53.62	---	-3.61	50.01	---	74.00	54.00	-3.99	Peak
1524.00	53.77	---	-3.04	50.73	---	74.00	54.00	-3.27	Peak
3210.00	41.13	---	4.95	46.08	---	74.00	54.00	-7.92	Peak
4005.00	41.46	---	6.77	48.23	---	74.00	54.00	-5.77	Peak
4935.00	39.07	---	9.05	48.12	---	74.00	54.00	-5.88	Peak

966 Chamber_B at 3Meter / Vertical									
Frequency (MHz)	Reading-PK (dBuV)	Reading-AV (dBuV)	Correction Factor (dB/m)	Result-PK (dBuV/m)	Result-AV (dBuV/m)	Limit-PK (dBuV/m)	Limit-AV (dBuV/m)	Margin (dB)	Remark
1032.00	55.06	---	-4.40	50.65	---	74.00	54.00	-3.35	Peak
1150.00	54.37	---	-4.13	50.25	---	74.00	54.00	-3.75	Peak
1296.00	53.61	---	-3.78	49.82	---	74.00	54.00	-4.18	Peak
1508.00	54.22	---	-3.21	51.01	---	74.00	54.00	-2.99	Peak
3270.00	42.12	---	5.00	47.12	---	74.00	54.00	-6.88	Peak
4005.00	41.98	---	6.77	48.76	---	74.00	54.00	-5.24	Peak
4305.00	41.58	---	7.40	48.99	---	74.00	54.00	-5.01	Peak
4920.00	38.95	---	9.01	47.96	---	74.00	54.00	-6.04	Peak

Remark:

1. Measuring frequencies from 1 GHz to the 10th harmonic of highest fundamental frequency.
2. Average test would be performed if the peak result were greater than the average limit.
3. Data of measurement within this frequency range shown " --- " in the table above means the reading of emissions are attenuated more than 20dB below the permissible limits or the field strength is too small to be measured.
4. Measurements above show only up to 6 maximum emissions noted, or would be lesser, with " N/A " remark, if no specific emissions from the EUT are recorded (ie: margin>20dB from the applicable limit) and considered that's already beyond the background noise floor.
5. Result = Reading + Correction Factor
Margin = Result - Limit
Remark Peak = Result(PK) - Limit(AV)
Remark AVG = Result(AV) - Limit(AV)



Restricted Band Edges

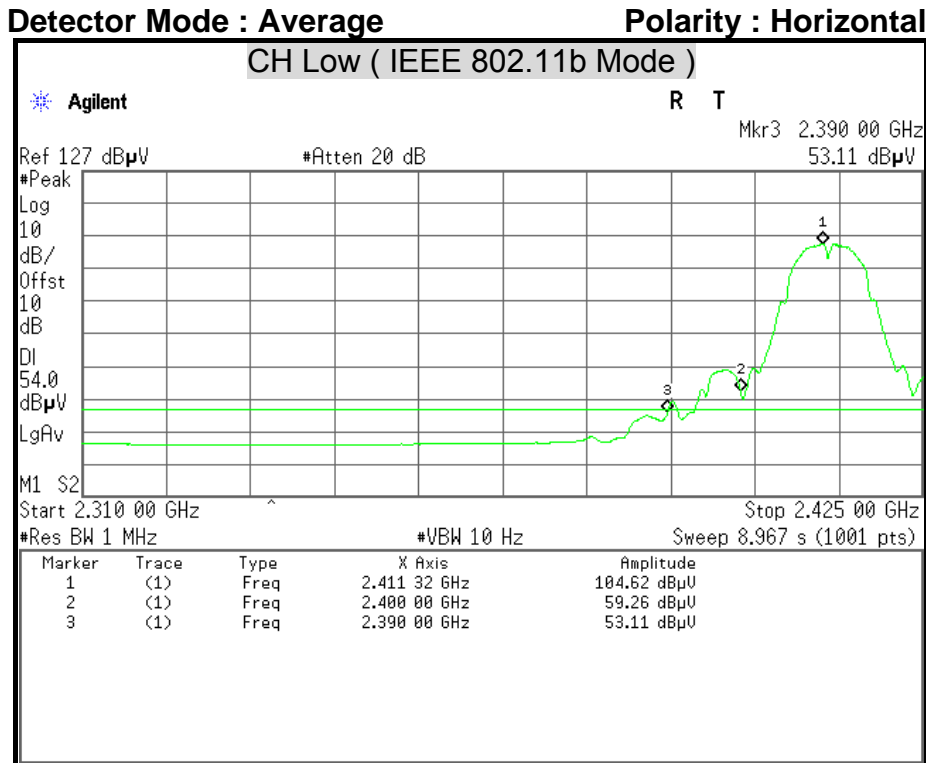
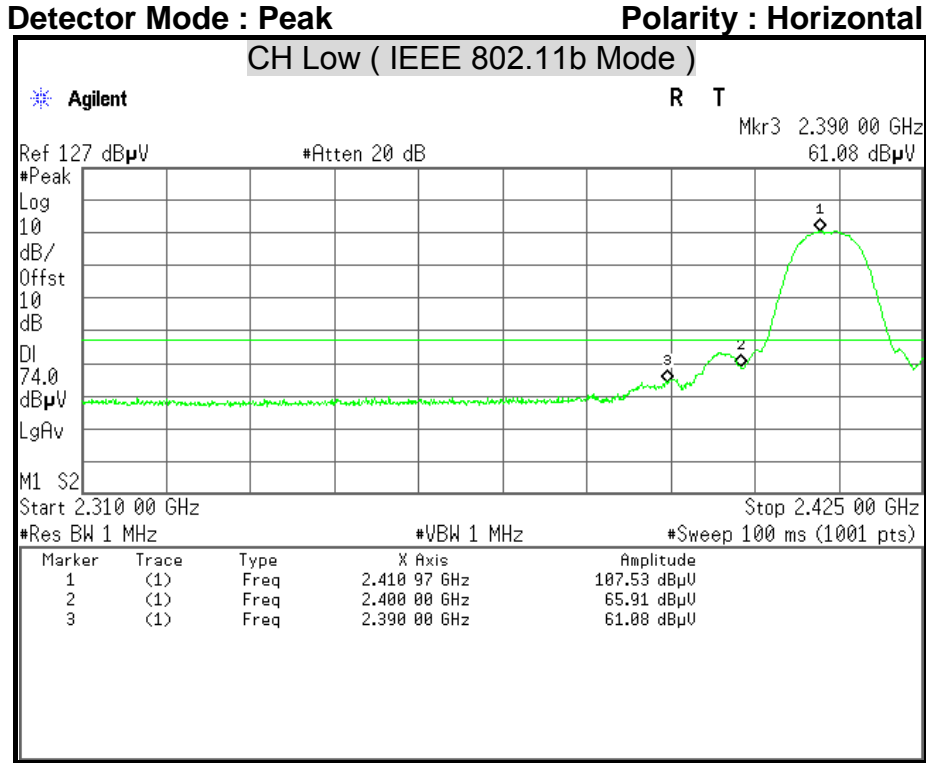



Detector Mode : Peak **Polarity : Vertical**

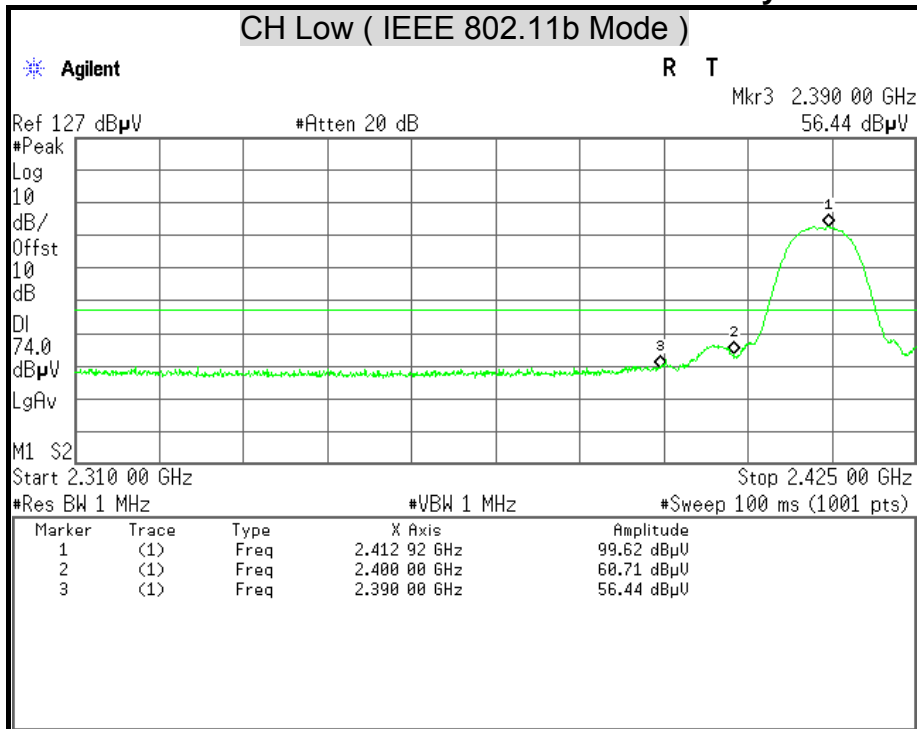

Detector Mode : Average **Polarity : Vertical**

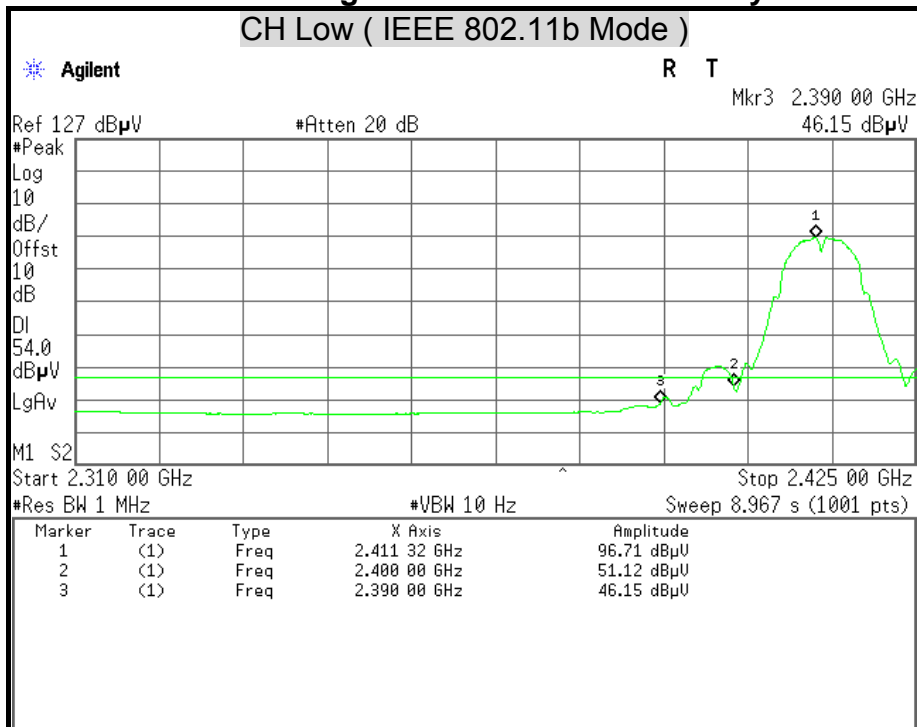



Detector Mode : Peak

Polarity : Horizontal

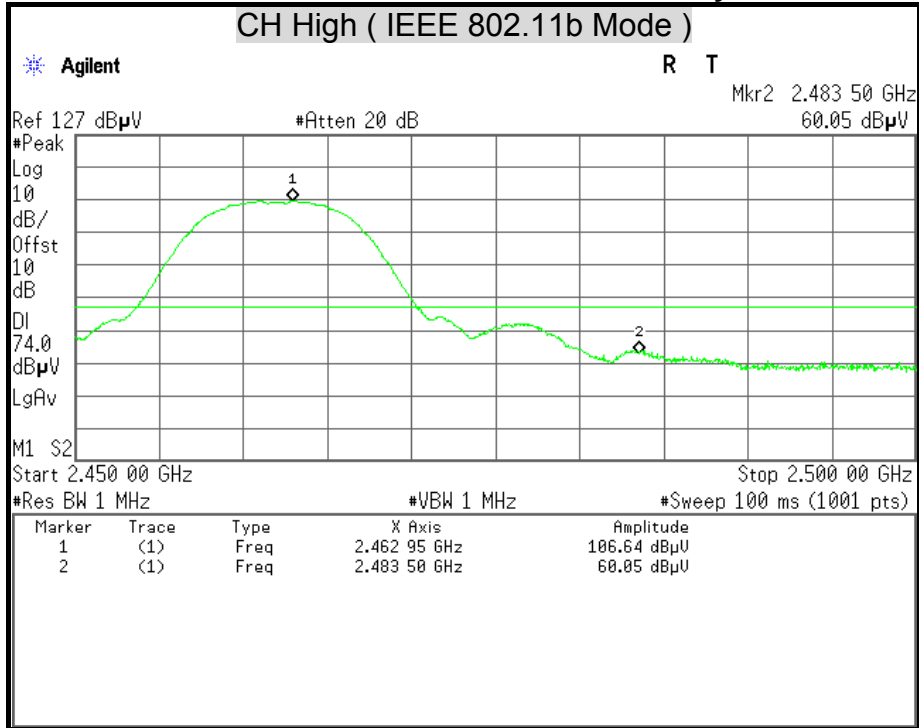

Detector Mode : Average

Polarity : Horizontal

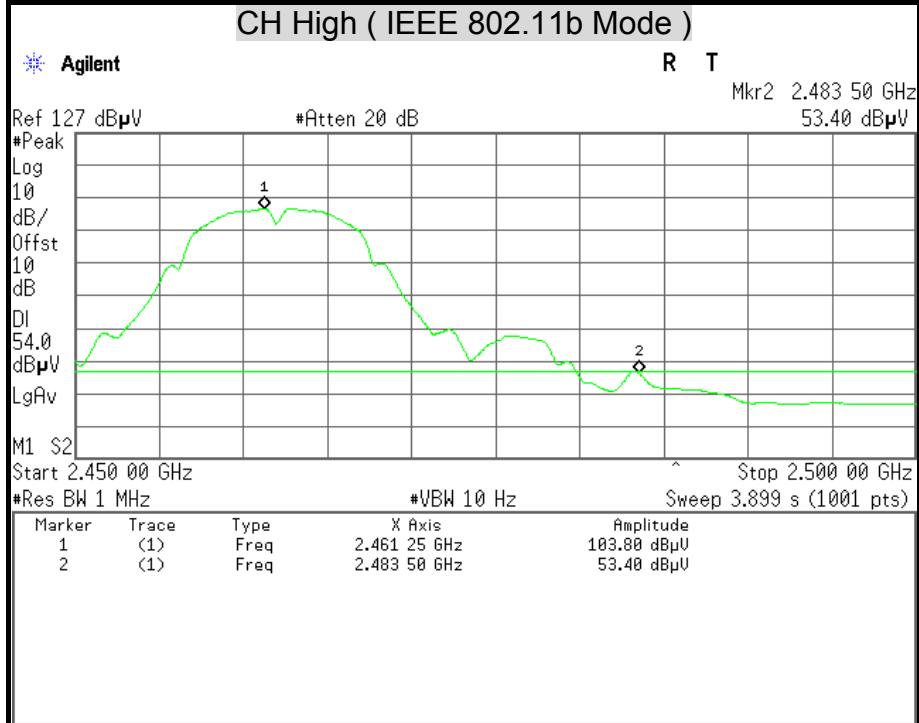



Detector Mode : Peak **Polarity : Vertical**

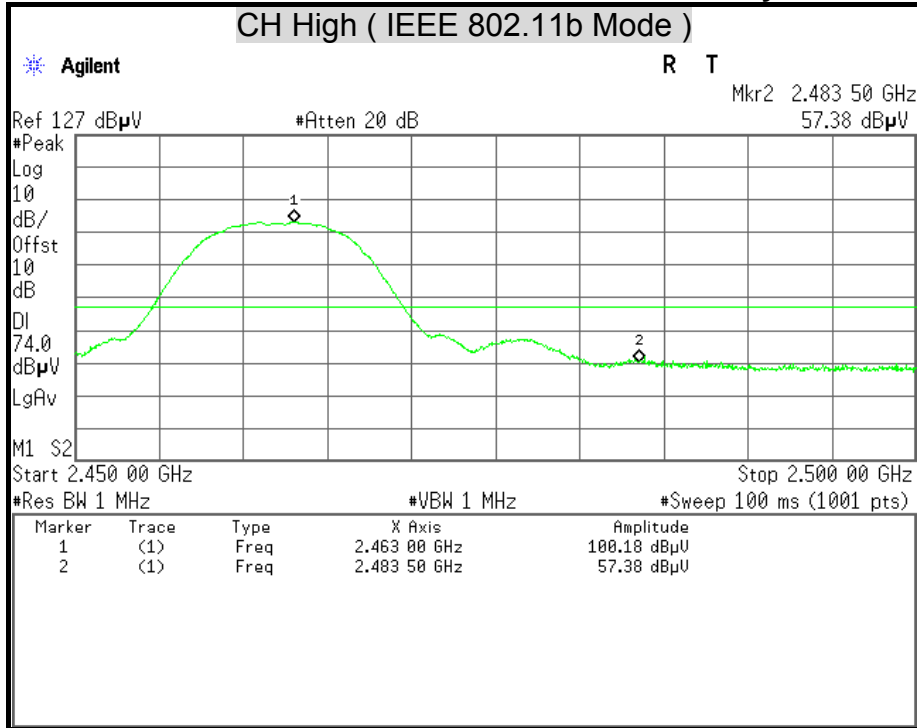

Detector Mode : Average **Polarity : Vertical**

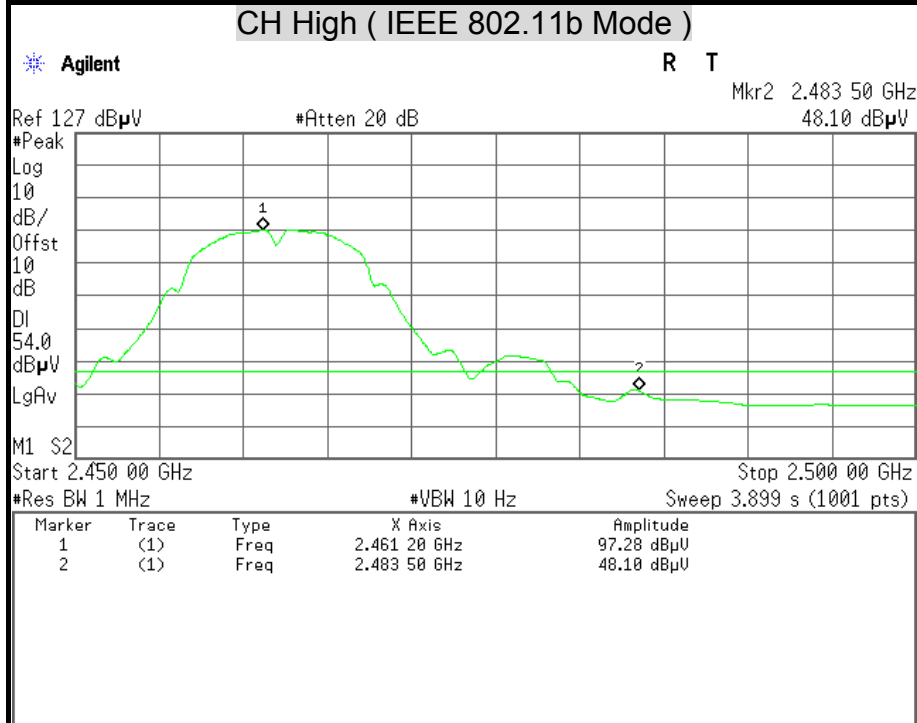



Detector Mode : Peak **Polarity : Vertical**

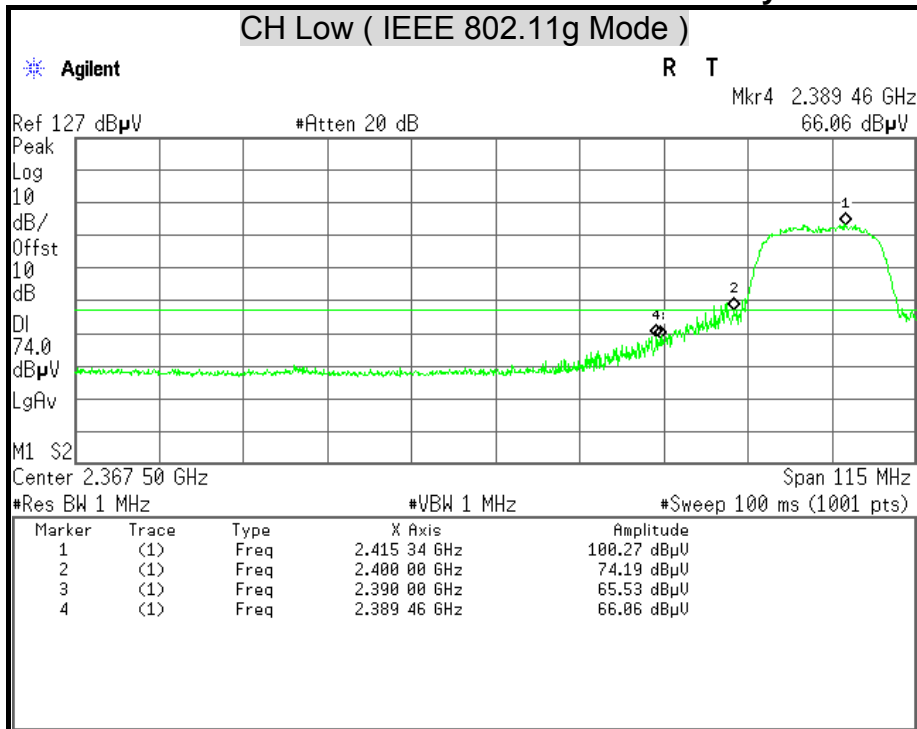

Detector Mode : Average **Polarity : Vertical**

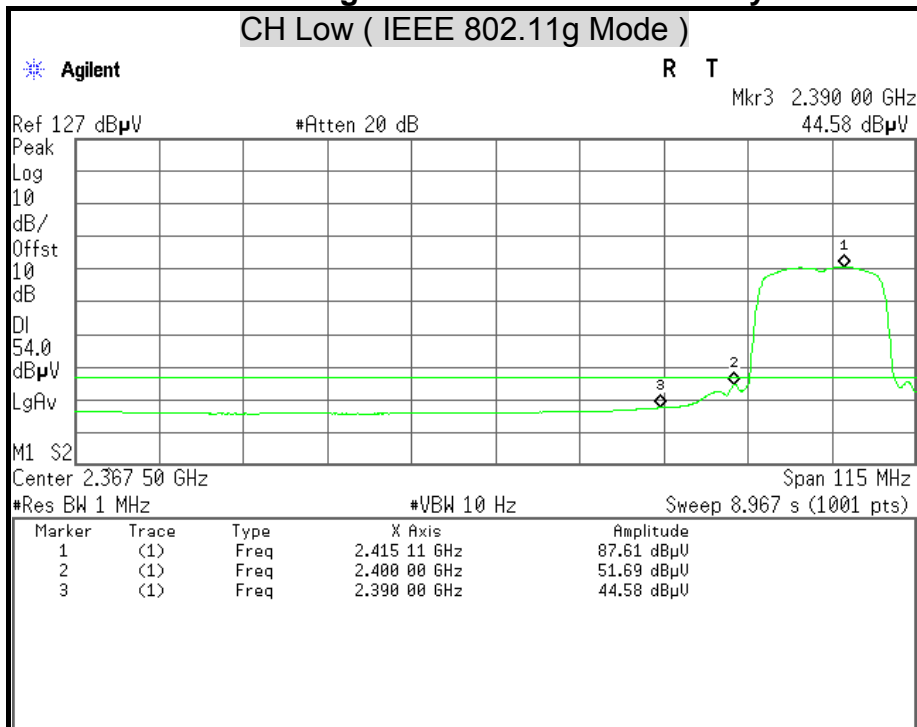



Detector Mode : Peak

Polarity : Horizontal

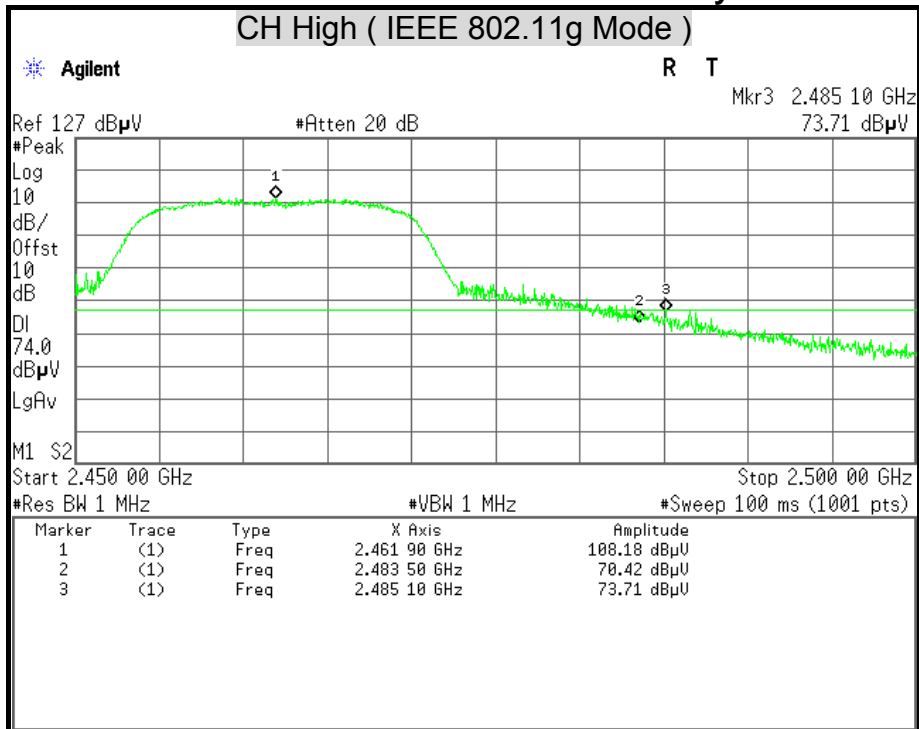

Detector Mode : Average

Polarity : Horizontal

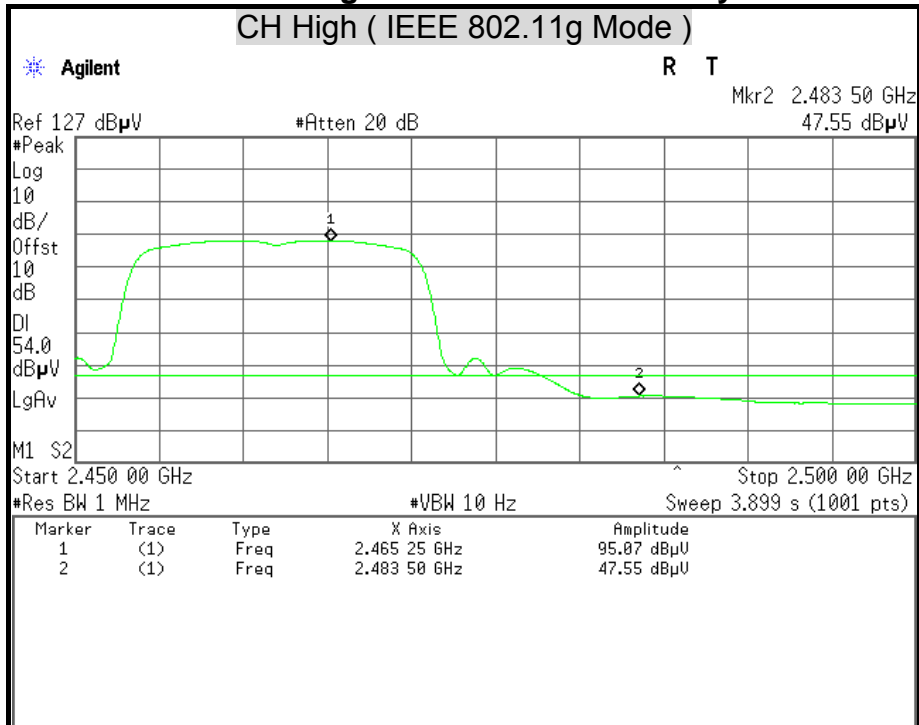



Detector Mode : Peak **Polarity : Vertical**

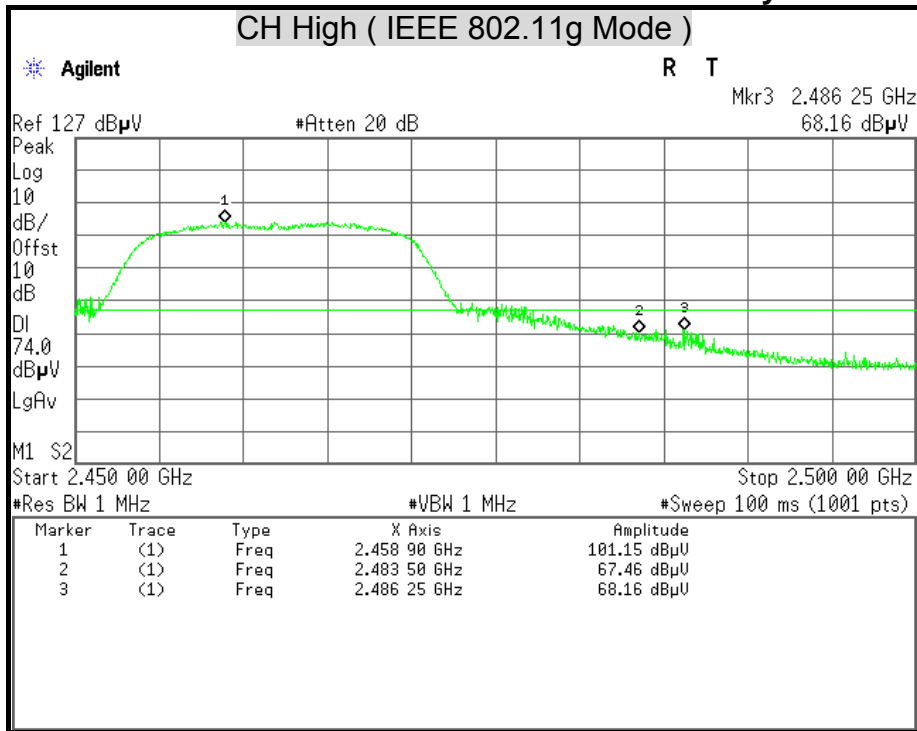

Detector Mode : Average **Polarity : Vertical**

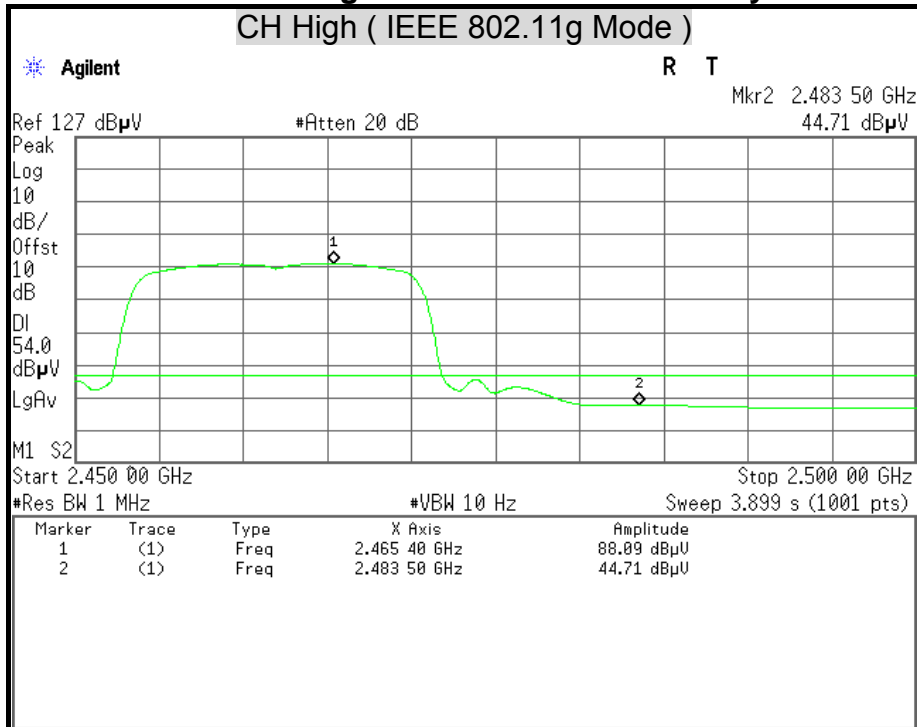



Detector Mode : Peak

Polarity : Horizontal

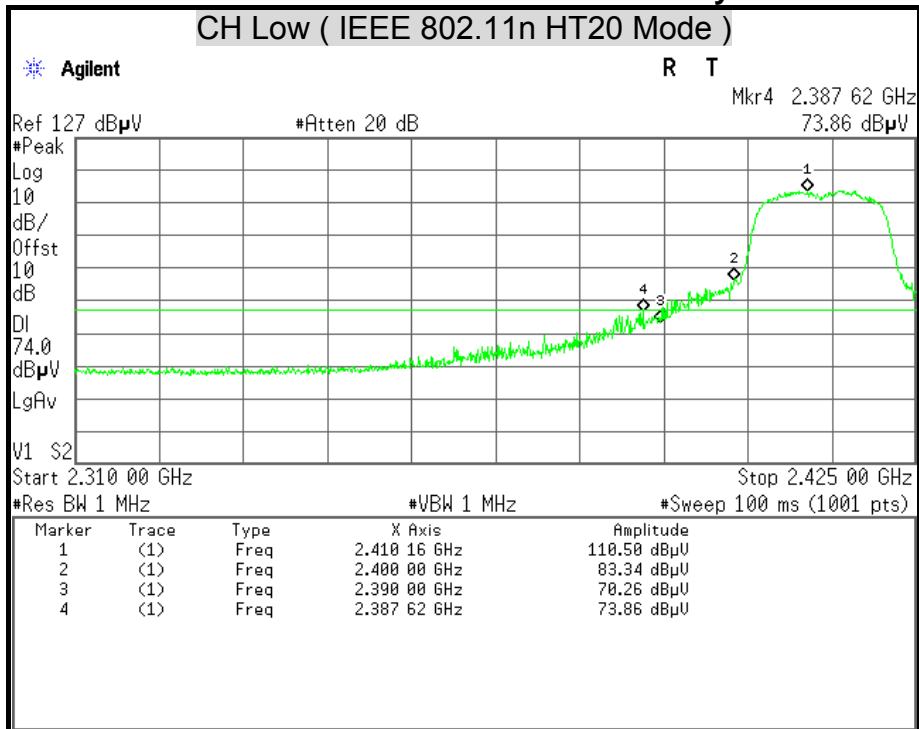

Detector Mode : Average

Polarity : Horizontal

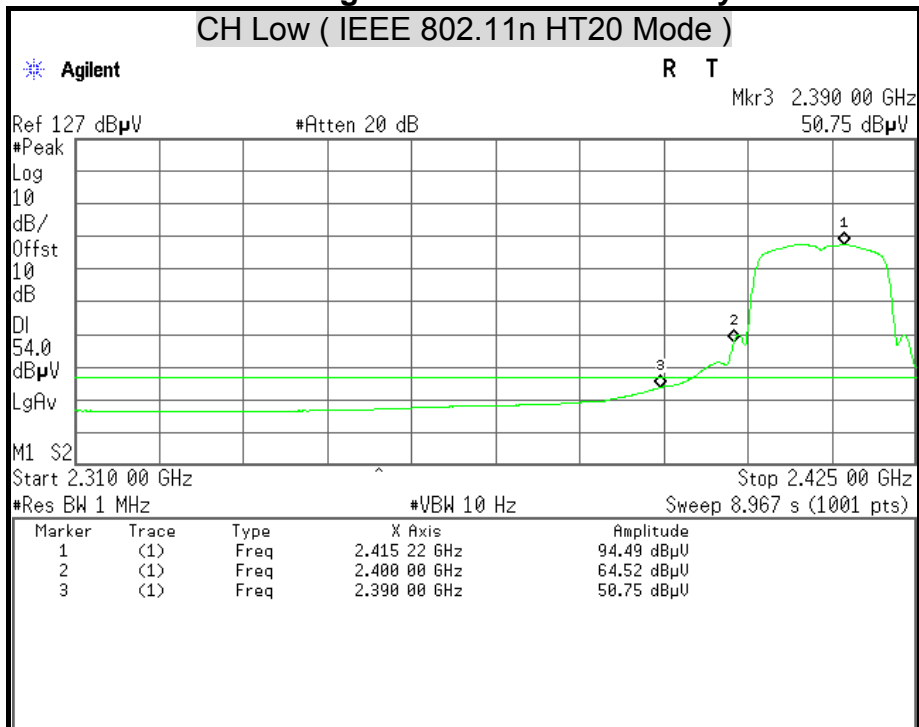



Detector Mode : Peak **Polarity : Vertical**

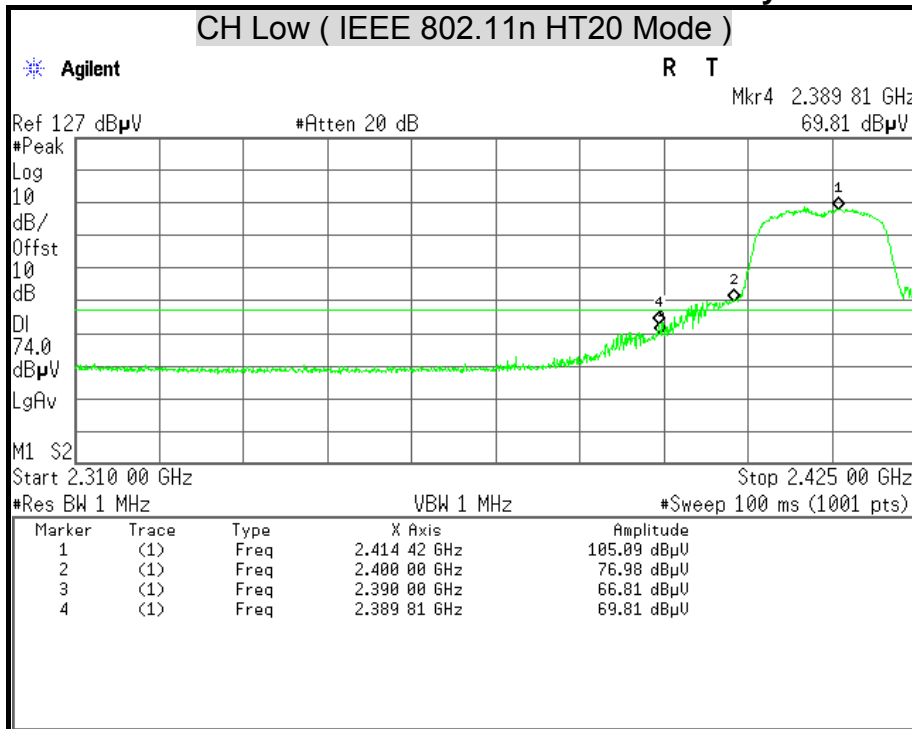

Detector Mode : Average **Polarity : Vertical**

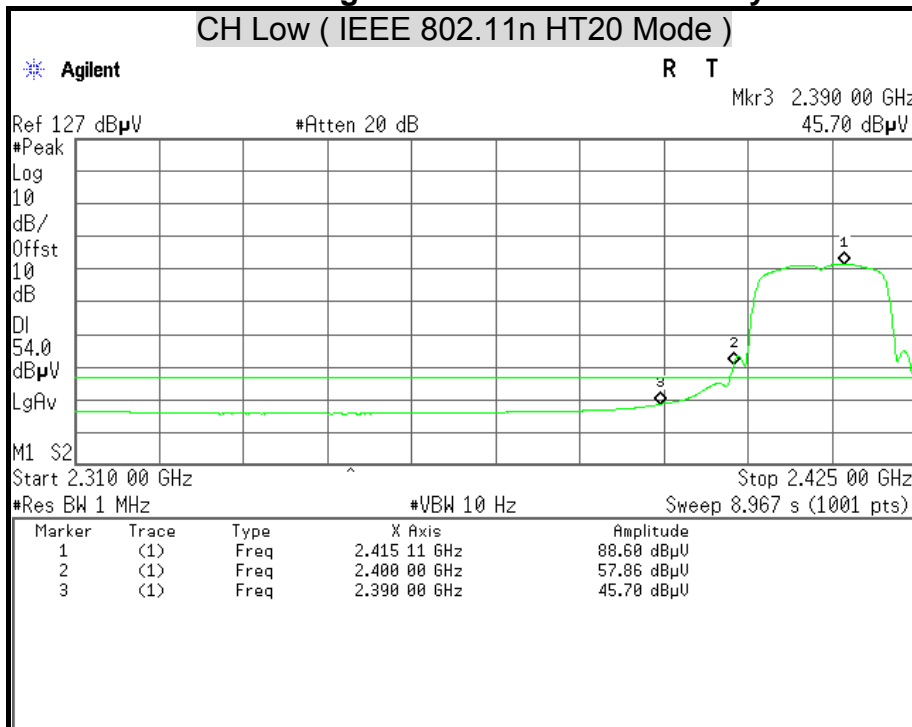



Detector Mode : Peak **Polarity : Vertical**

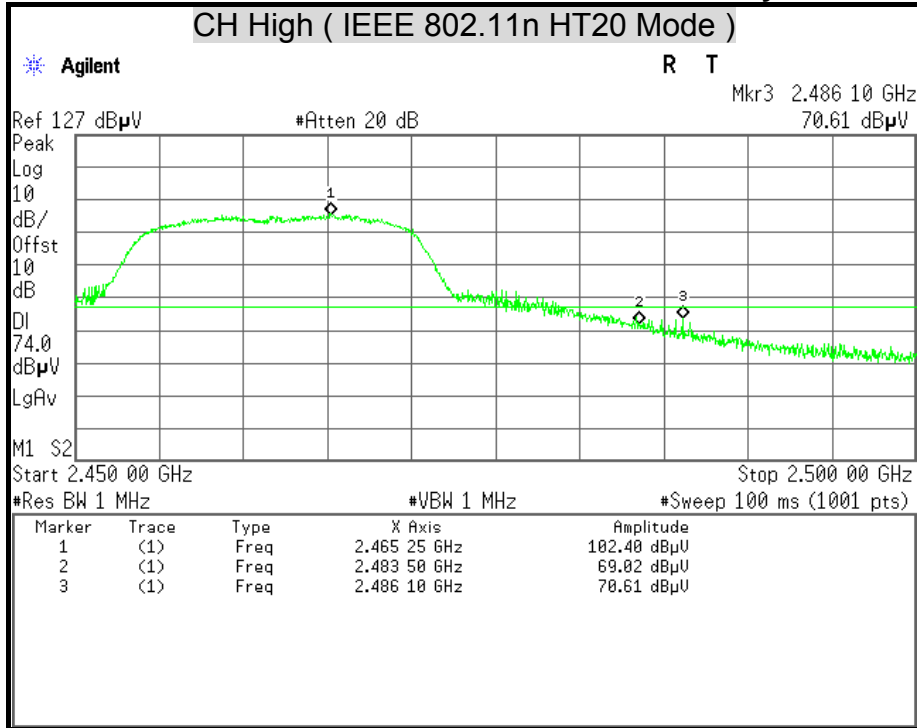

Detector Mode : Average **Polarity : Vertical**

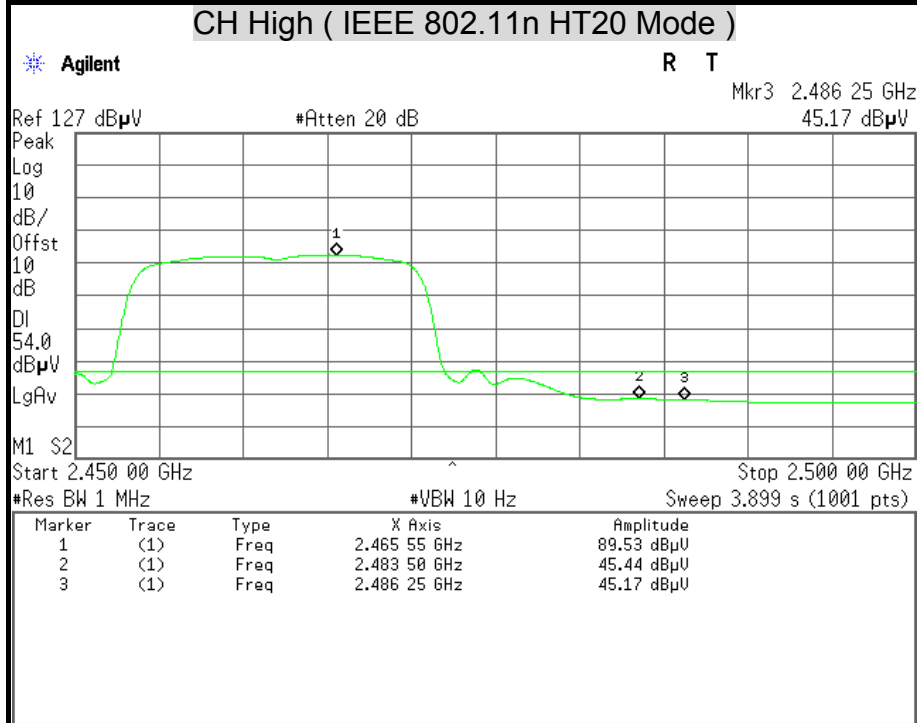



Detector Mode : Peak

Polarity : Horizontal

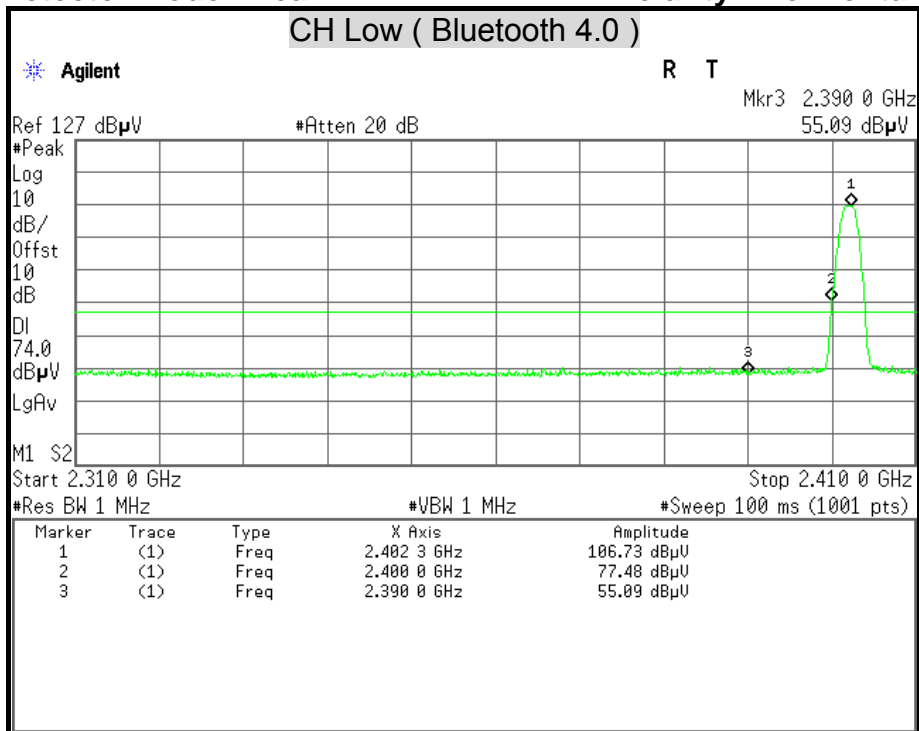

Detector Mode : Average

Polarity : Horizontal

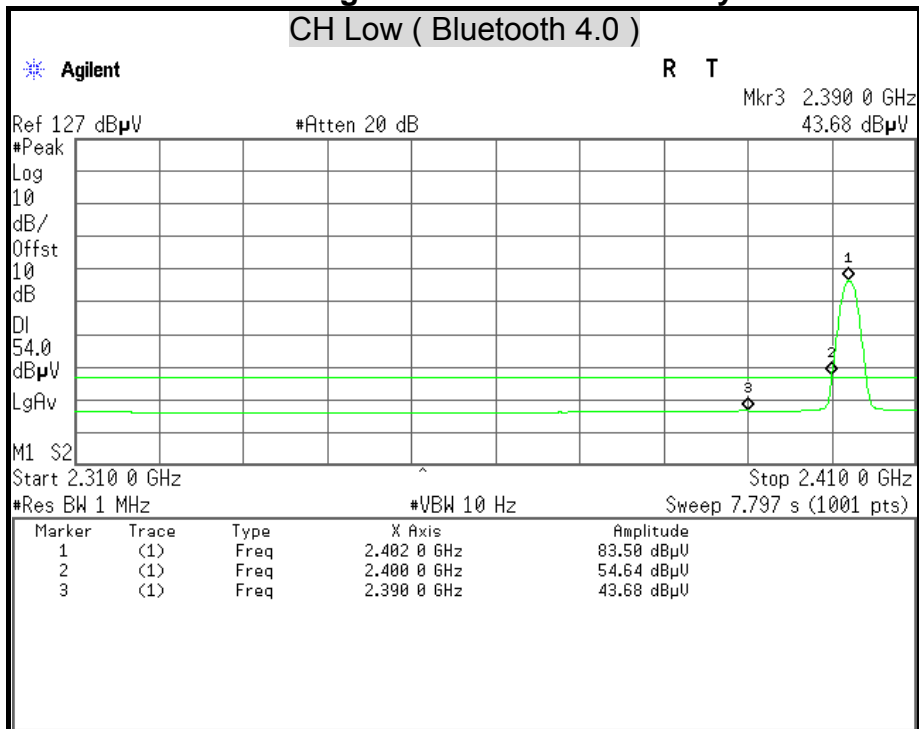



Detector Mode : Peak **Polarity : Vertical**

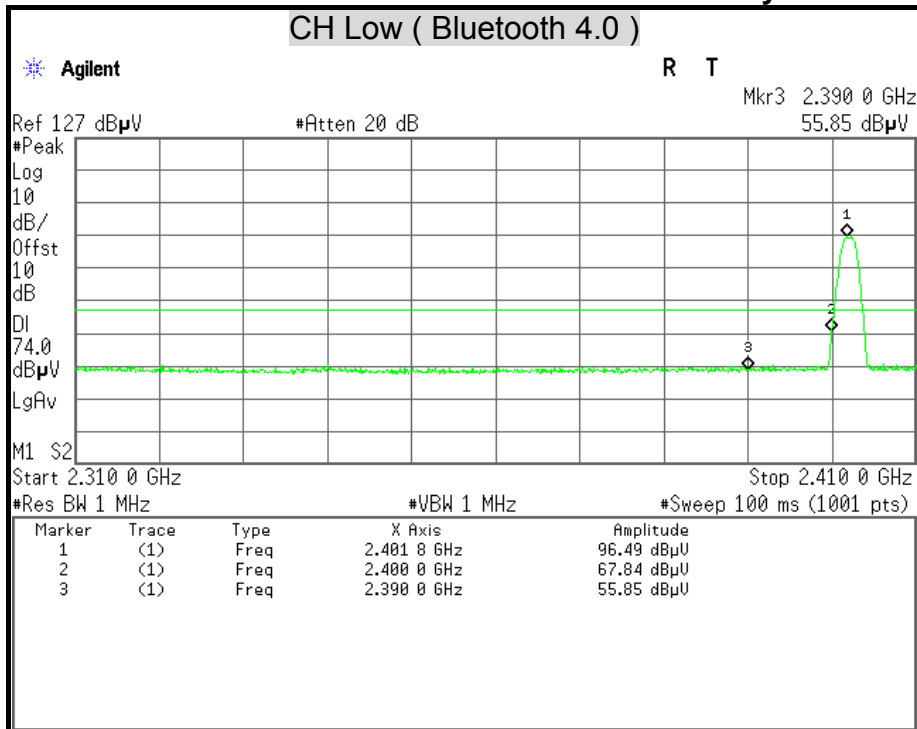

Detector Mode : Average **Polarity : Vertical**

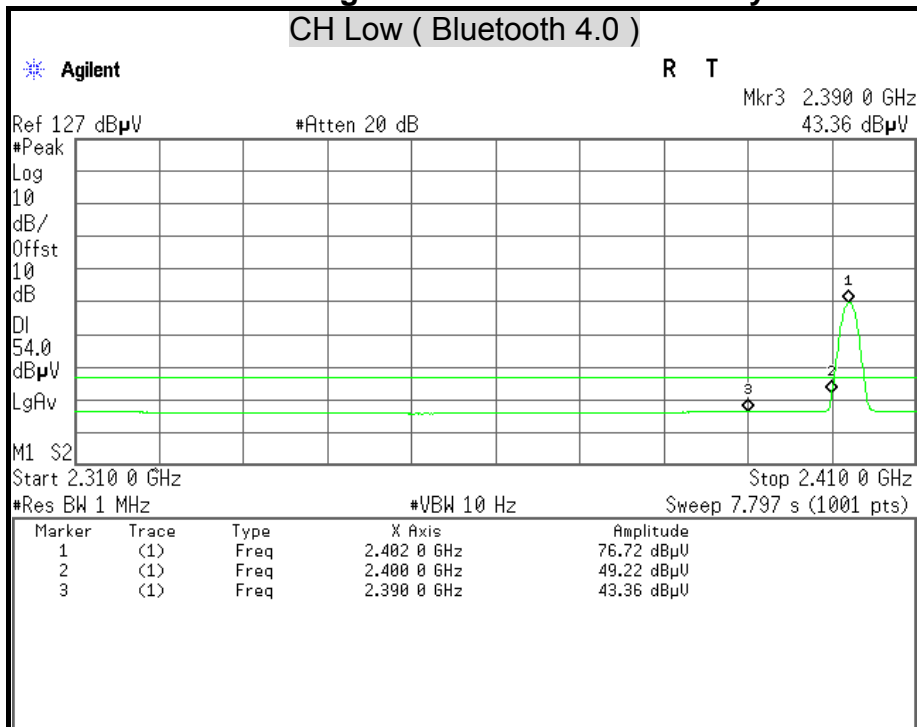



Detector Mode : Peak

Polarity : Horizontal

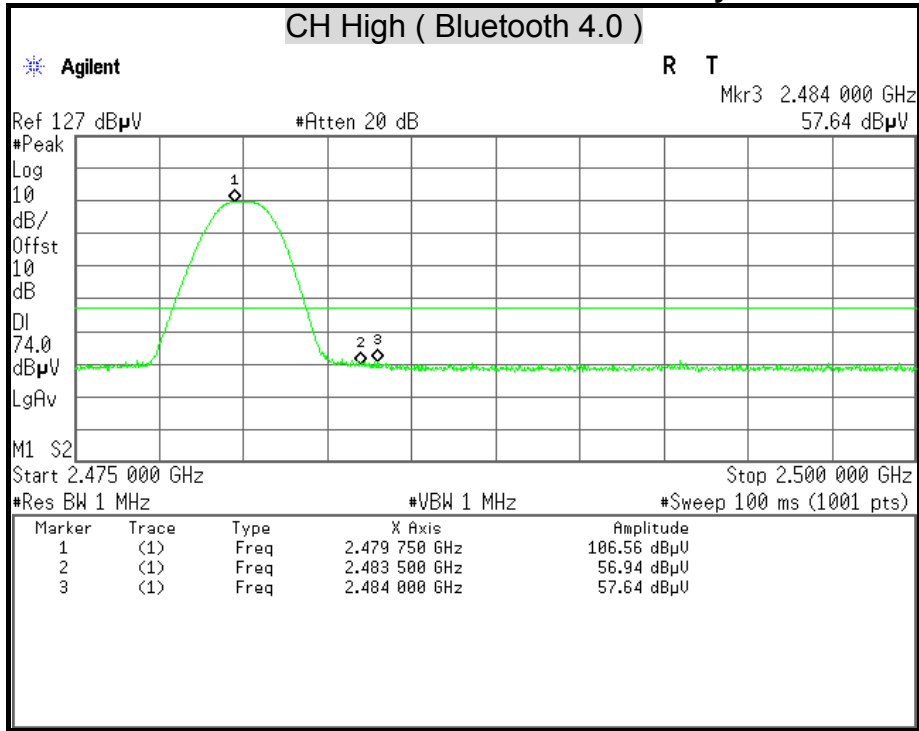

Detector Mode : Average

Polarity : Horizontal

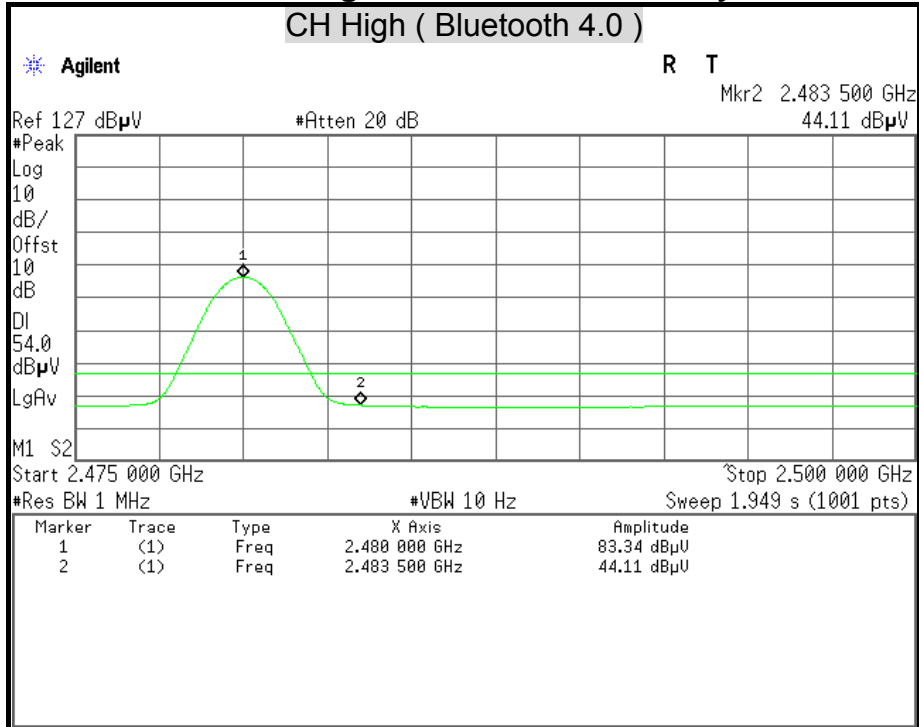



Detector Mode : Peak

Polarity : Vertical

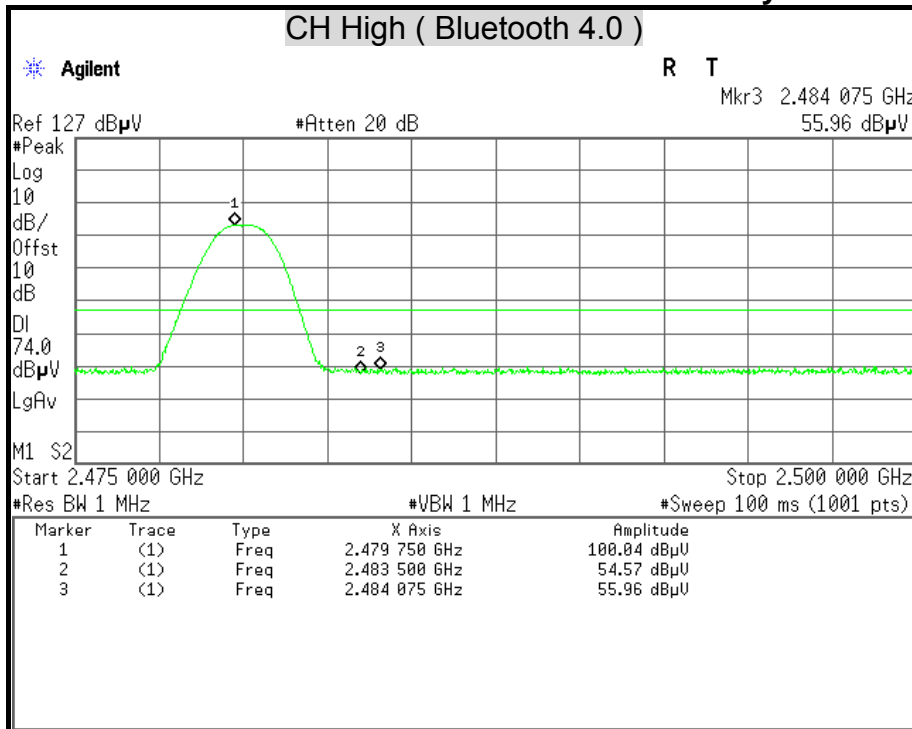

Detector Mode : Average

Polarity : Vertical

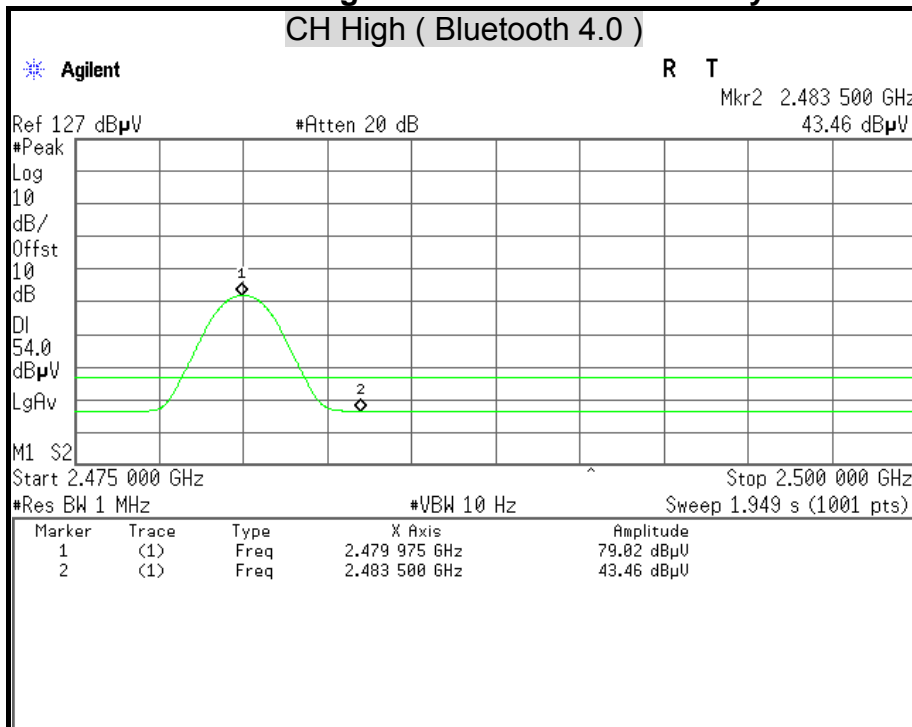



7.7 CONDUCTED EMISSION

LIMITS

§ 15.207 (a) Except as shown in paragraph (b) and (c) this section, for an intentional radiator that is designed to be connected to the public utility (AC) power line, the radio frequency voltage that is conducted back onto the AC power line on any frequency or frequencies within the band 150 kHz to 30 MHz shall not exceed the limits in the following table, as measured using a 50 µH/50 ohms line impedance stabilization network (LISN). Compliance with the provisions of this paragraph shall be based on the measurement of the radio frequency voltage between each power line and ground at the power terminal. The lower limit applies at the boundary between the frequency ranges.

Frequency Range (MHz)	Conducted Limit (dBµv)	
	Quasi-peak	Average
0.15 - 0.50	66 to 56	56 to 46
0.50 - 5.00	56	46
5.00 - 30.0	60	50

TEST EQUIPMENT

Name of Equipment	Manufacturer	Model	Serial Number	Calibration Due
L.I.S.N	SCHWARZBECK	NSLK 8127	8127-465	08/11/2014
L.I.S.N	SCHWARZBECK	NSLK 8127	8127-473	03/07/2014
EMI Receiver	ROHDE & SCHWARZ	ESCS 30	835418/008	10/16/2014
Pulse Limiter	ROHDE & SCHWARZ	ESH3-Z2	100117	07/01/2014

Remark: Each piece of equipment is scheduled for calibration once a year.



TEST SETUP

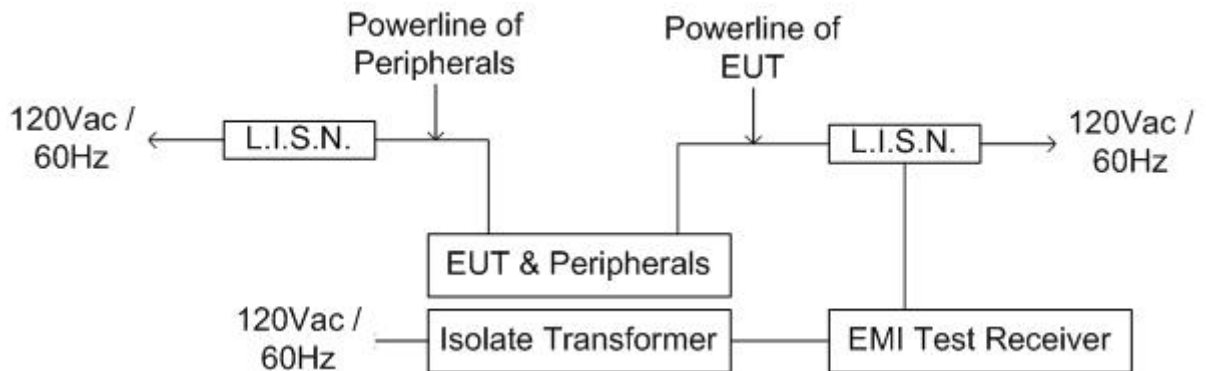
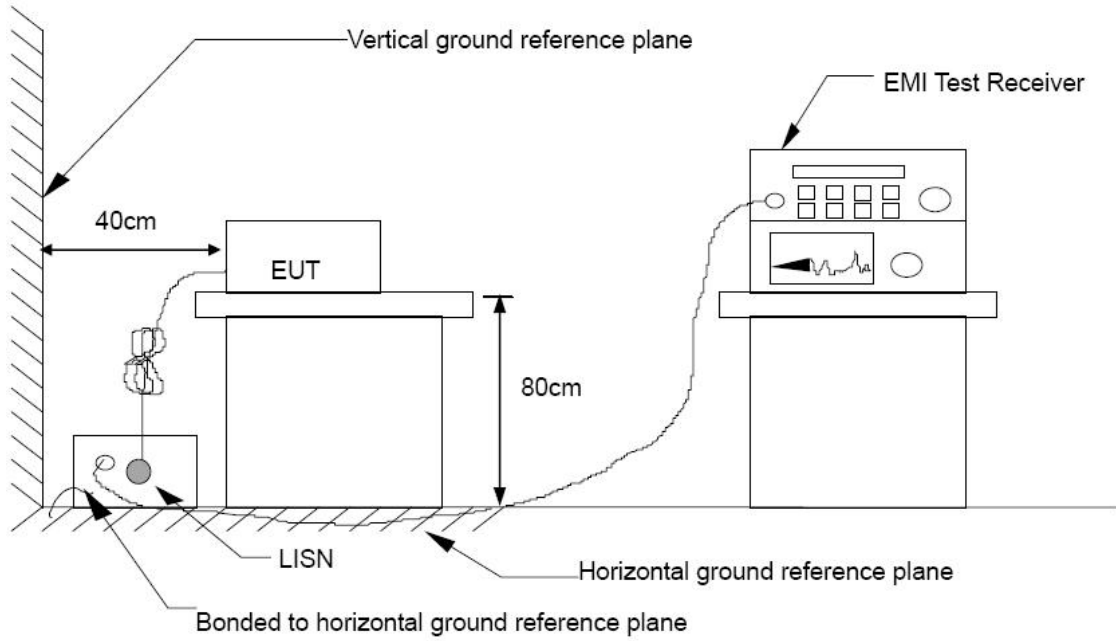



TEST PROCEDURE

The basic test procedure was in accordance with ANSI C63.4:2009.

The test procedure is performed in a 4m × 3m × 2.4m (L×W×H) shielded room.

The EUT along with its peripherals were placed on a 1.0m (W) × 1.5m (L) and 0.8m in height wooden table and the EUT was adjusted to maintain a 0.4 meter space from a vertical reference plane.

The EUT was connected to power mains through a line impedance stabilization network (LISN) which provides 50 ohm coupling impedance for measuring instrument and the chassis ground was bounded to the horizontal ground plane of shielded room. All peripherals were connected to the second LISN and the chassis ground also bounded to the horizontal ground plane of shielded room.

The EUT was located so that the distance between the boundary of the EUT and the closest surface of the LISN is 0.8 m. Where a mains flexible cord was provided by the manufacturer shall be 1 m long, or if in excess of 1 m, the excess cable was folded back and forth as far as possible so as to form a bundle not exceeding 0.4 m in length.



TEST RESULTS

Product Name	Nuvola	Test By	Rueyyan Lin
Test Model	NP-1	Test Date	2013/11/14
Test Mode	TX Mode	Temp. & Humidity	22°C, 52%

LINE

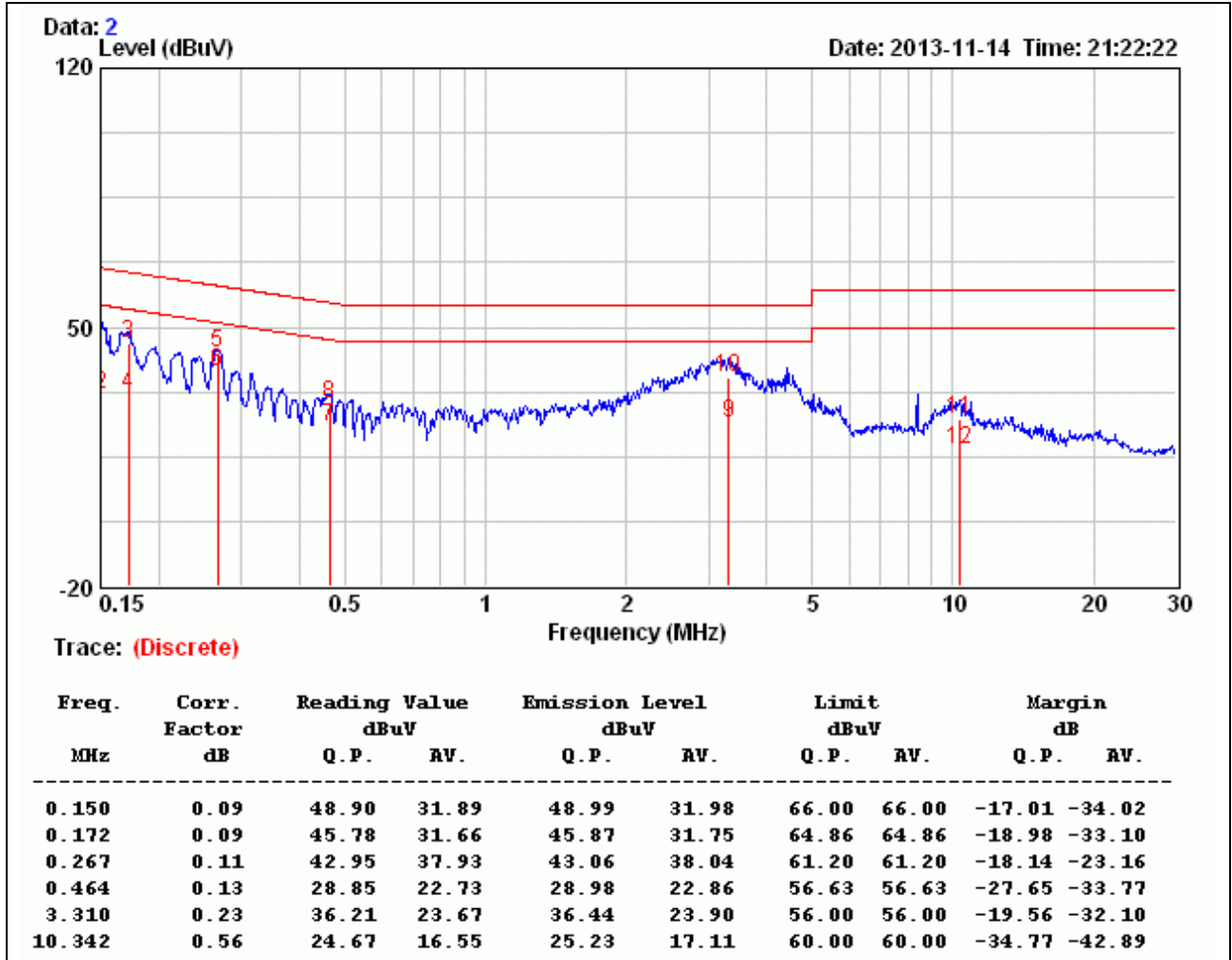

Remark:

1. Correction Factor = Insertion loss + Cable loss
2. Emission level = Reading Value + Correction factor
3. Margin value = Emission level – Limit value



Product Name	Nuvola	Test By	Rueyyan Lin
Test Model	NP-1	Test Date	2013/11/14
Test Mode	TX Mode	Temp. & Humidity	22°C, 52%

NEUTRAL

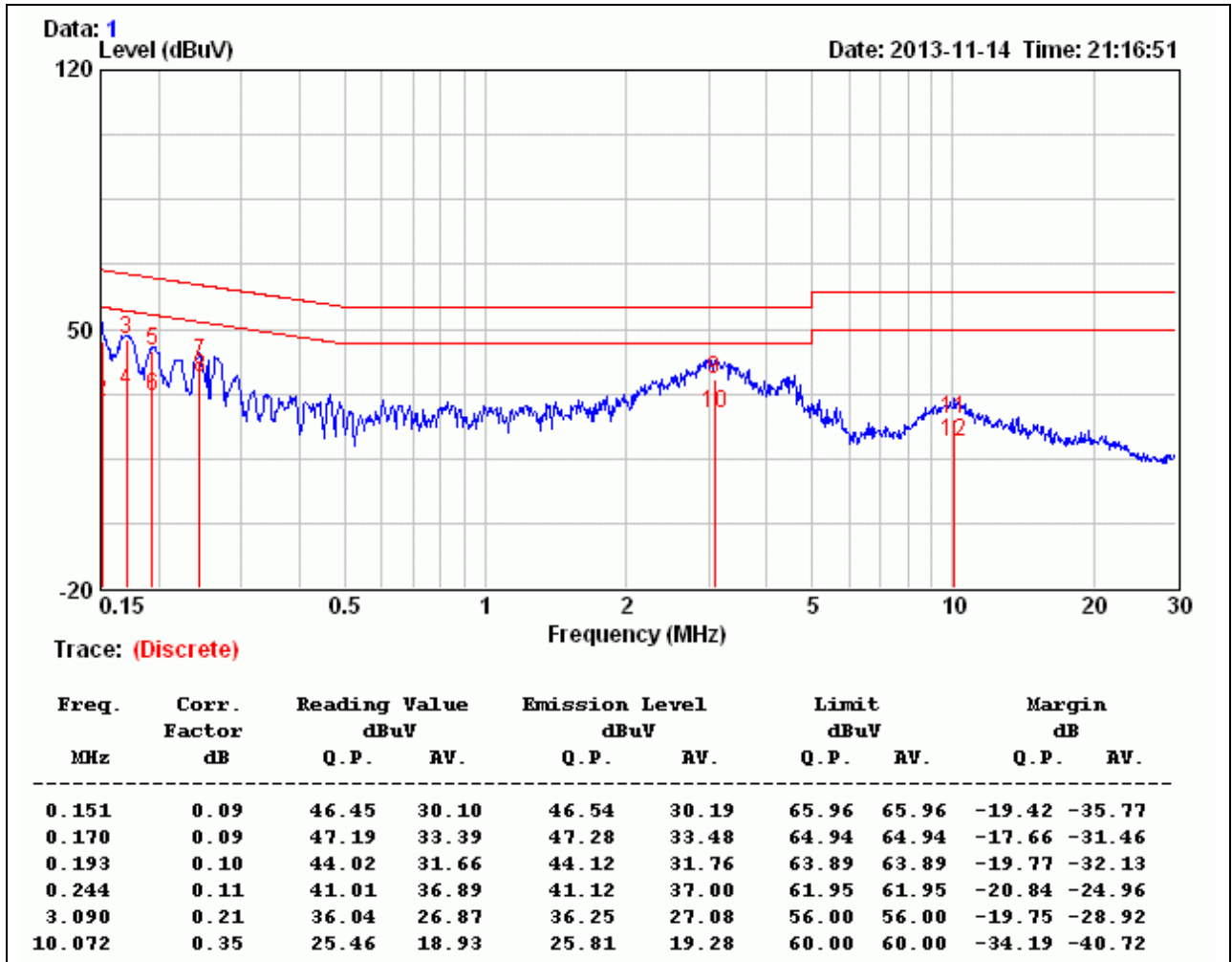

Remark:

1. Correction Factor = Insertion loss + Cable loss
2. Emission level = Reading Value + Correction factor
3. Margin value = Emission level – Limit value