



TEST REPORT

Applicant Name & Address : Zhongshan Grand Enterprise Co.,Ltd
No.2 Yihui North Road,Zone B, Maohui Industry,Henglan Town, Zhongshan City, Guangdong, China. 528478

Sample Description
Product : Super switch
Model No. : CZ2003-2+3
Electrical Rating : 125V, 60Hz, 10A
FCC ID : 2AAK4GRAND

Date Received : 14 June 2013

Date Test Conducted : 18 June 2013 – 09 July 2013

Test standards : FCC Part 15:2011

Test Result : Pass

Conclusion : The submitted samples complied with the above rules/standards.

Remark : None.

*****End of Page*****

Prepared and Checked By:

Approved By:

Doctang Tang
Doctang Tang
Engineer
Intertek Guangzhou

Helen Ma *Signature*
Helen Ma
Sr.Project Engineer
Intertek Guangzhou
22 July 2013 *Date*

This report is for the exclusive use of Intertek's Client and is provided pursuant to the agreement between Intertek and its Client. Intertek's responsibility and liability are limited to the terms and conditions of the agreement. Intertek assumes no liability to any party, other than to the Client in accordance with the agreement, for any loss, expense or damage occasioned by the use of this report. Only the Client is authorized to permit copying or distribution of this report and then only in its entirety. Any use of the Intertek name or one of its marks for the sale or advertisement of the tested material, product or service must first be approved in writing by Intertek. The observations and test results in this report are relevant only to the sample tested. This report by itself does not imply that the material, product, or service is or has ever been under an Intertek certification program. The test report only allows to be revised within three years from its original issued date unless further standard or the requirement was noticed.

Intertek Testing Services Shenzhen Ltd. Guangzhou Branch
Block E, No.7-2 Guang Dong Software Science Park, Caipin Road, Guangzhou Science City, GETDD Guangzhou, China
Tel / Fax: 86-20-8213 9688/86-20-3205 7538

CONTENT

TEST REPORT 1

CONTENT 2

1 TEST RESULTS SUMMARY 3

2 TEST RESULTS CONCLUSION 4

3 LABORATORY MEASUREMENTS 5

4 TEST RESULTS 6

4.1 CONDUCTED EMISSION TEST 6

4.1.1 *Used Test Equipment* 6

4.1.2 *Block Diagram of Test Setup* 6

4.1.3 *Test Setup and Procedure* 7

4.1.4 *Test Data* 8

4.1.5 *Emission Curve* 10

4.1.6 *Measurement Uncertainty* 10

4.2 RADIATED EMISSION 11

4.2.1 *Used Test Equipment* 11

4.2.2 *Block Diagram of Test Setup* 11

4.2.3 *Field Strength Calculation* 12

4.2.4 *Test Setup and Procedure* 13

4.2.5 *Test Data* 13

4.2.6 *Test Curve* 14

4.2.7 *Measurement uncertainty* 14

1

TEST RESULTS SUMMARY

Classification of EUT: Class B

Test Item	Standard	Result
Conducted Emission	FCC Part 15, Subpart B: 2011	Pass
Radiated Emission	FCC Part 15, Subpart B: 2011	Pass

Remark: 1. The symbol “N/A” in above table means Not Applicable.

2. When determining the test results, measurement uncertainty of tests has been considered.

Test Results Conclusion (with Justification)

RE: EMC Testing Pursuant to FCC Part 15, Subpart B: 2011 Performed On the Super switch, Model: CZ2003-2+3.

We tested Super switch, Model: CZ2003-2+3, to determine if it was in compliance with the relevant FCC rules as marked on the Test Results Summary. We found that the unit met the requirement of FCC Part 15, Subpart B: 2011 when tested as received. The worst case's test data was presented in this test report. Test items Conducted Emission and Radiated Emission were subcontracted.

The Equipment Under Test (EUT) is controlled by a controller, the controller is an intentional radiator using 315MHz frequency.

Antenna Type: Integral wire antenna.

The controller option of this receiver is subject to Certification procedure.

The data on the below test result table lists the significant emission frequencies, the limit and the margin of compliance. Numbers with a minus sign are below the limit.

The production units are required to conform to the initial sample as received when the units are placed on the market.

3 LABORATORY MEASUREMENTS

Configuration Information

Equipment Under Test (EUT):	Super switch
Model:	CZ2003-2+3
Serial No.	Not Labelled
Support Equipment:	A controller
Rated Voltage:	125V/60Hz
Condition of Environment:	Temperature : 15~35°C Relative Humidity: 35~60% Atmosphere Pressure 86~106kPa

Notes:

1. Test Environment

If ambient levels of emissions exceed the appropriate limit, the following steps were taken to assure compliance. First, the measurement bandwidth was reduced, if this did not affect the peak readings. Such a reduction can allow much closer examination of emissions close to local ambient signals. Second, the antenna could be brought closer to the EUT. Finally, in severe cases, testing was re-performed at night or other times when the offending signal was off the air. The measurements were made at nominal room temperature ($25^{\circ}\text{C} \pm 10^{\circ}\text{C}$).

2. Test Site

Conducted Emission test and Radiated Emission test were subcontracted to Keyway Technology Co.,Ltd. located at Baishun Industrial Zone, Zhangmotou Town, Dongguan, Guangdong, China 523638. This test facility and site measurement data have been fully placed on file with the FCC, test firm registration number is 370994.

3. Test Platform

Radiated emission and Conducted emission tests were made on 0.8m high, 1m x 1.5m wide non-conductive platform on the reference ground plane. The vertical conducting plane or wall of a screened room shall be located 40 cm to the rear of the EUT. All other surfaces of EUT shall be at least 80 cm from any other grounded conducting surface, including the case or cases of one or more LISNs.

4. Measurement Uncertainty

When determining of the test conclusion, the Measurement Uncertainty of test has been considered.

4 TEST RESULTS

4.1 Conducted Emission Test

Test Result: Pass

4.1.1 Used Test Equipment

Equip No.	Description	Manufacturer	Model No.	Cal. Date	Due Date
101156	EMI Test Receiver	Rohde&Schwarz	ESCI	07 Jul 2013	07 Jul 2014
101315	Artificial Mains Network	Rohde&Schwarz	ENV216	02 Jul 2013	02 Jul 2014
944 Cable	RF Cable	FUJIKURA	3D-2W	02 Jul 2013	02 Jul 2013

4.1.2 Block Diagram of Test Setup

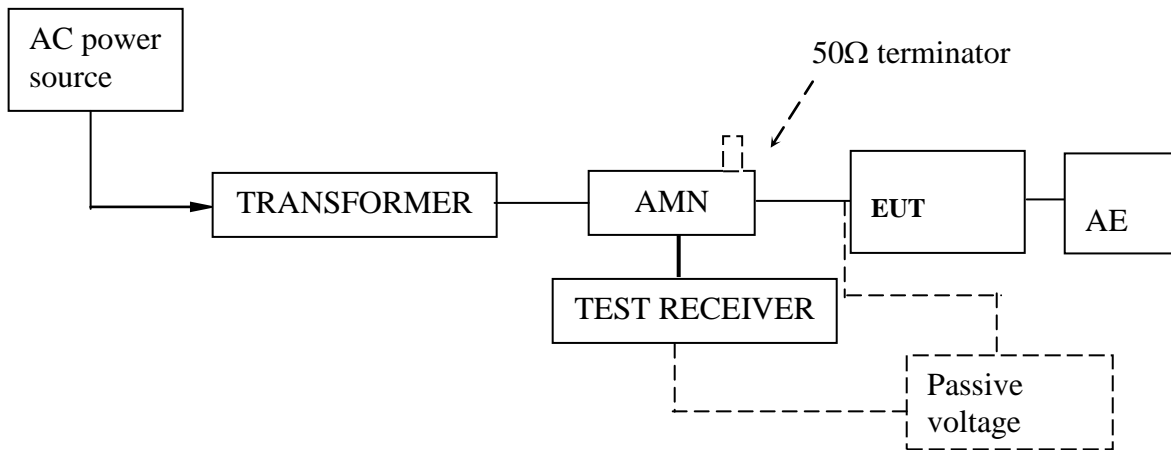

4.1.3 Test Setup and Procedure

Test was performed according to ANSI C63.4: 2009. The EUT was set to achieve the maximum emission level. The mains terminal disturbance voltage was measured with the EUT in a shielded room. The EUT was connected to AC power source through an Artificial Mains Network which provides a 50Ω linear impedance Artificial hand is used if appropriate (for handheld apparatus). The load/control terminal disturbance voltage was measured with passive voltage probe if appropriate.

The vertical conducting plane or wall of a screened room shall be located 40 cm to the rear of the EUT. All other surfaces of tabletop EUTs shall be at least 80 cm from any other grounded conducting surface, including the case or cases of one or more LISNs The table-top EUT was placed on a 0.8m high non-metallic table above earthed ground plane(Ground Reference Plane).And for floor standing EUT, was placed on a 12mm high non-metallic supported on GRP. The Artificial Mains Network is situated at a distance of 0.8m from the EUT.

During the test, mains lead of EUT excess 0.8m was folded back and forth parallel to the lead so as to form a horizontal bundle with a length between 0.3m and 0.4m.

The bandwidth of test receiver was set at 9 kHz. The frequency range from 150 kHz to 30MHz was checked.



4.1.4 Test Data

At main terminal: Pass

Operation Mode: receive mode

L line:

Frequency [MHz]	Quasi-Peak		Average	
	Disturbance level [dB(μV)]	Permitted limit [dB(μV)]	Disturbance level [dB(μV)]	Permitted limit [dB(μV)]
0.160	<45	65.5	<35	55.5
0.240	<42	62.1	<32	52.1
0.550	<36	56.0	<26	46.0
1.000	<36	56.0	<26	46.0
1.400	<36	56.0	<26	46.0
2.000	<36	56.0	<26	46.0
3.500	<36	56.0	<26	46.0
6.000	<40	60.0	<30	50.0
10.000	<40	60.0	<30	50.0
22.000	<40	60.0	<30	50.0
30.000	<40	60.0	<30	50.0



N line:

Frequency [MHz]	Quasi-Peak		Average	
	Disturbance level	Permitted limit	Disturbance level	Permitted limit
	[dB(μV)]	[dB(μV)]	[dB(μV)]	[dB(μV)]
0.160	<45	65.5	<35	55.5
0.240	<42	62.1	<32	52.1
0.550	<36	56.0	<26	46.0
1.000	<36	56.0	<26	46.0
1.400	<36	56.0	<26	46.0
2.000	<36	56.0	<26	46.0
3.500	<36	56.0	<26	46.0
6.000	<40	60.0	<30	50.0
10.000	<40	60.0	<30	50.0
22.000	<40	60.0	<30	50.0
30.000	<40	60.0	<30	50.0

4.1.5 Emission Curve Tested Wire: Live

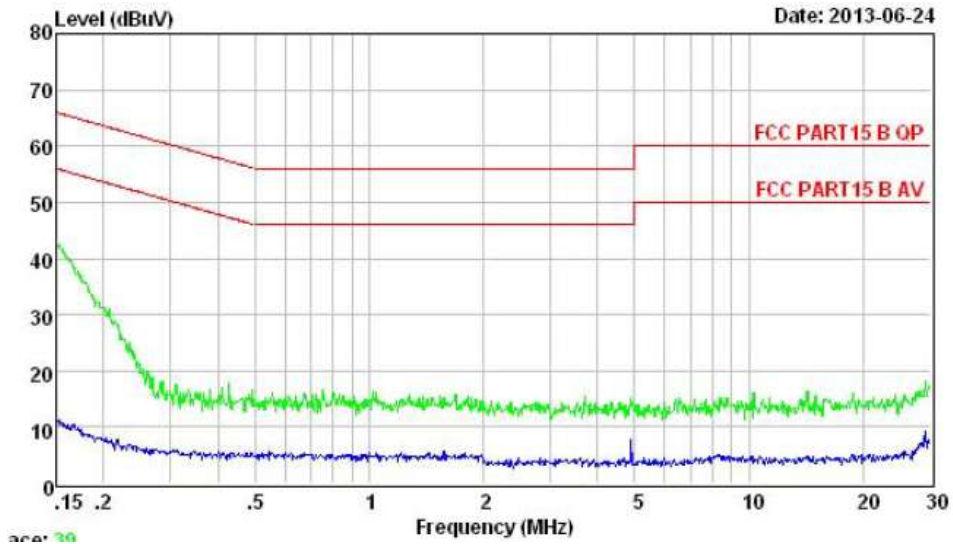

Tested Wire: Neutral

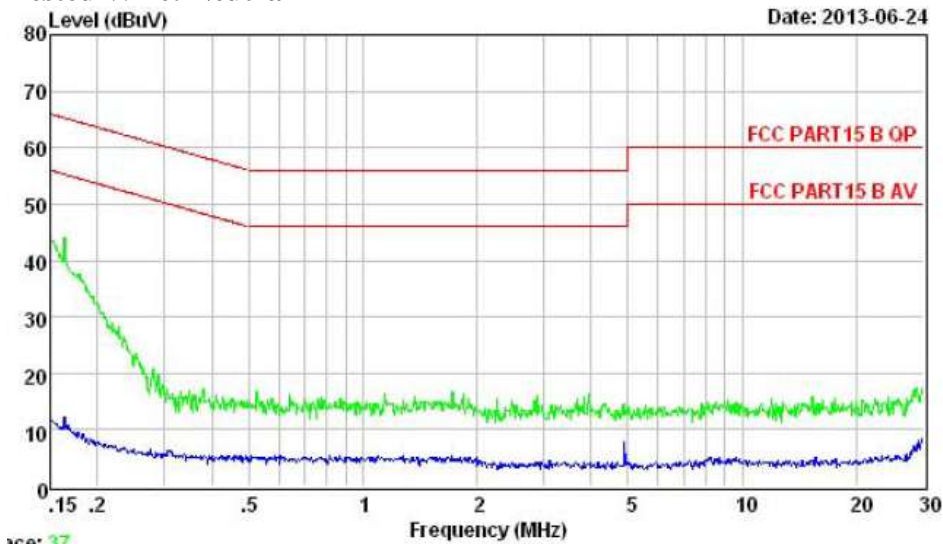

4.1.6 Measurement Uncertainty

Uncertainty: 2.50 dB at a level of confidence of 95%

4.2 Radiated Emission
Test Result: Pass

4.2.1 Used Test Equipment

Equipment No.	Equipment	Manufacturer	Model No.	Cal. Date	Due Date
101156	EMI Test Receiver	Rohde&Schwarz	ESCI	07 Jul 2013	07 Jul 2014
00135452	Bilog Antenna	ETS-LINDGREN	3142D	28 Jun. 2013	28 Jun 2014
3911A04271	Spectrum Analyzer	Agilent	8593E	28 Nov. 2012	28 Nov. 2013
KW01	3m Semi-anechoic Chamber	ETS-LINDGREN	966	07 Jul 2013	07 Jul 2014
187303	Signal Amplifier	SONOMA	310	07 Jul 2013	07 Jul 2014
966 Cable 1#	RF Cable	IMRO	IMRO-400	07 Jul 2013	07 Jul 2014
11003	Horn Antenna	DAZE	ZN30701	11 Jul 2013	11 Jul 2014
11001	Signal Amplifier	DAZE	ZN3380C	07 Jul 2013	07 Jul 2014
966 Cable 1#	RF Cable	IMRO	IMRO-400	07 Jul 2013	07 Jul 2014

4.2.2 Block Diagram of Test Setup

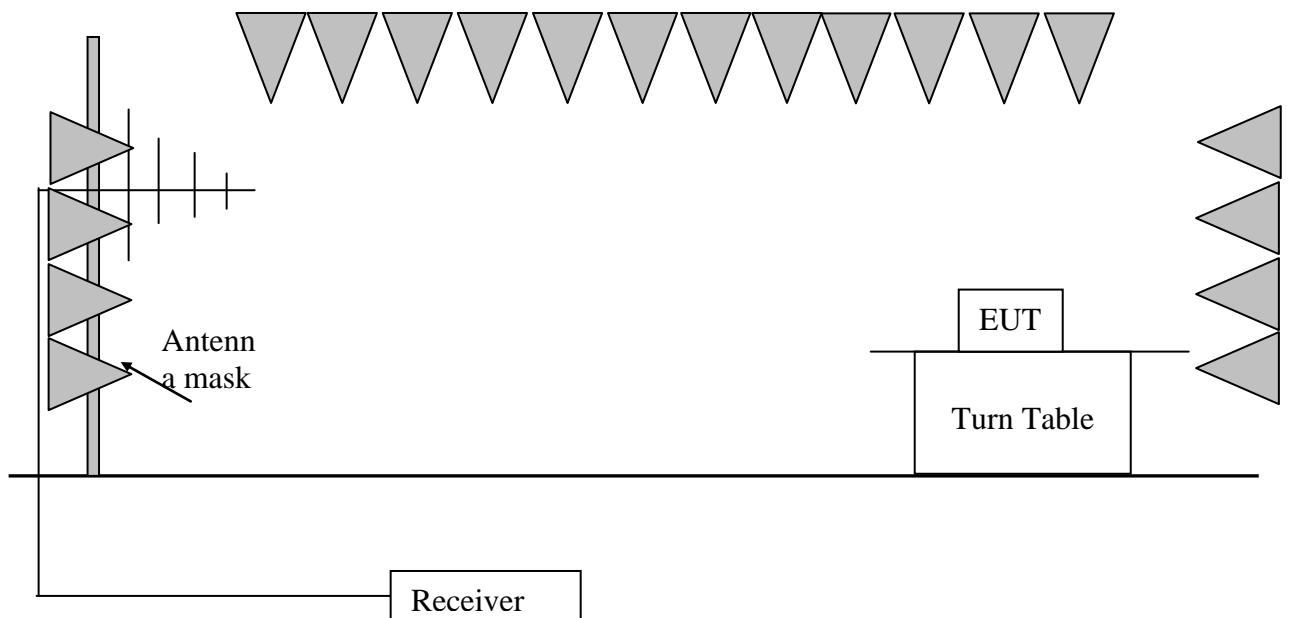

4.2.3 Field Strength Calculation

The field strength is calculated by adding the Antenna Factor and Cable Factor, and subtracting the Amplifier Gain (if any), Average Factor (optional) from the measured reading. The basic equation with a sample calculation is as follows:

$$\begin{aligned} & \text{FS} = \text{RA} + \text{AF} + \text{CF} - \text{AG} + \text{AV} \\ \rightarrow & \text{FS} = \text{RA} + \text{Correct Factor} + \text{AV} \\ & \text{where FS} = \text{Field Strength in dB}\mu\text{V/m} \\ & \text{RA} = \text{Receiver Amplitude (including preamplifier) in dB}\mu\text{V} \\ & \text{CF} = \text{Cable Attenuation Factor in dB} \\ & \text{AF} = \text{Antenna Factor in dB} \\ & \text{AG} = \text{Amplifier Gain in dB} \\ & \text{AV} = \text{Average Factor in -dB} \\ & \text{Correct Factor} = \text{AF} + \text{CF} - \text{AG} \end{aligned}$$

In the following table(s), the reading shown on the data table reflects the preamplifier gain. An example for the calculations in the following table is as follows:

$$\text{FS} = \text{RA} + \text{Correct Factor} + \text{AV}$$

Assume a receiver reading of 52.0 dB μ V is obtained. The antenna factor of 7.4 dB and cable factor of 1.6 dB are added. The amplifier gain of 29 dB and average factor of 5 dB are subtracted, giving a field strength of 27 dB μ V/m. This value in dB μ V/m was converted to its corresponding level in μ V/m.

$$\begin{aligned} \text{RA} &= 52.0 \text{ dB}\mu\text{V/m} \\ \text{AF} &= 7.4 \text{ dB} \\ \text{CF} &= 1.6 \text{ dB} \\ \text{AG} &= 29.0 \text{ dB} \\ \text{AV} &= -5.0 \text{ dB} \\ \text{Correct Factor} &= -20 \\ \text{FS} &= 52.0 - 20 - 5.0 = 27.0 \text{ dB}\mu\text{V/m} \end{aligned}$$

$$\text{Level in } \mu\text{V/m} = \text{Common Antilogarithm} [(27 \text{ dB}\mu\text{V/m})/20] = 22.4 \mu\text{V/m}$$

4.2.4 Test Setup and Procedure

The measurement was applied in a 3 m semi-anechoic chamber. The EUT was placed on a 12mm thick insulating material above the reference ground plane. The turn table rotated 360 degrees to determine the position of the maximum emission level. The EUT was set 3 meters away from the receiving antenna which was mounted on an antenna mask. The antenna moved up and down between from 1meter to 4 meters to find out the maximum emission level.

Broadband antenna was used as receiving antenna. Both horizontal and vertical polarization of the antenna was set on measurement. In order to find the maximum emission, all of the interface cables were manipulated according to ANSI C63.4: 2009 requirement during radiated test. The bandwidth setting on R&S Test Receiver was 120 kHz. The frequency range from 30MHz to 2000MHz was checked

4.2.5 Test Data

1. Quasi-peak detector was used at below 1GHz, peak detector was used at above 1GHz.
2. All measurements were made at 3 meter.
- 3 The emissions found were at least 20 dB below the limit, so they need not reported according FCC part 15.31(o)



4.2.6 Test Curve

Horizontal:

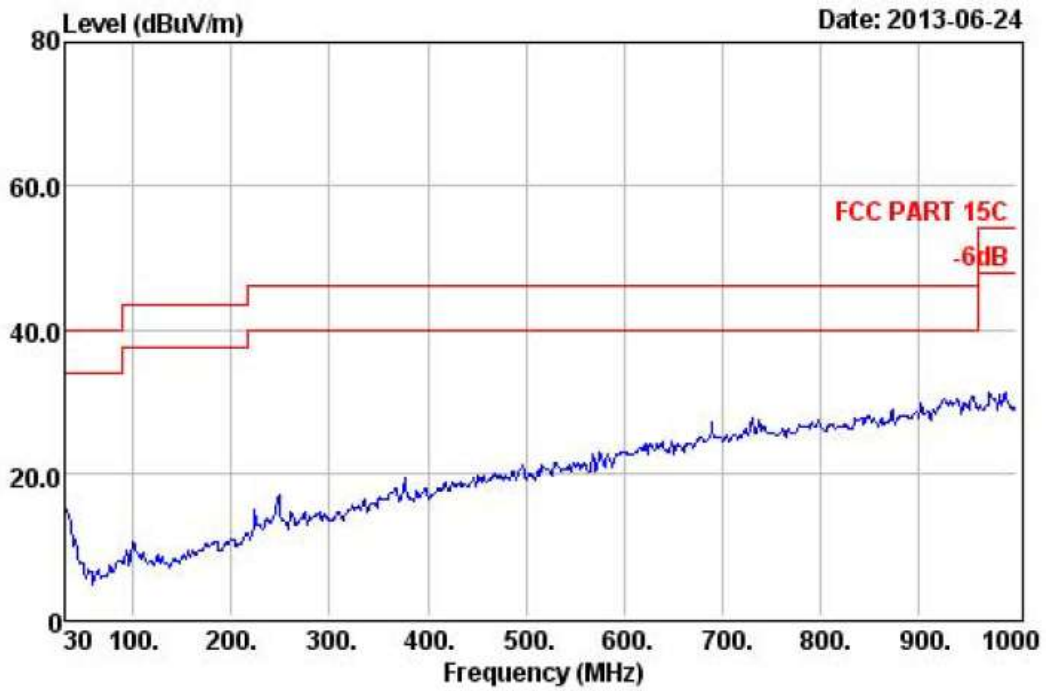

Vertical:

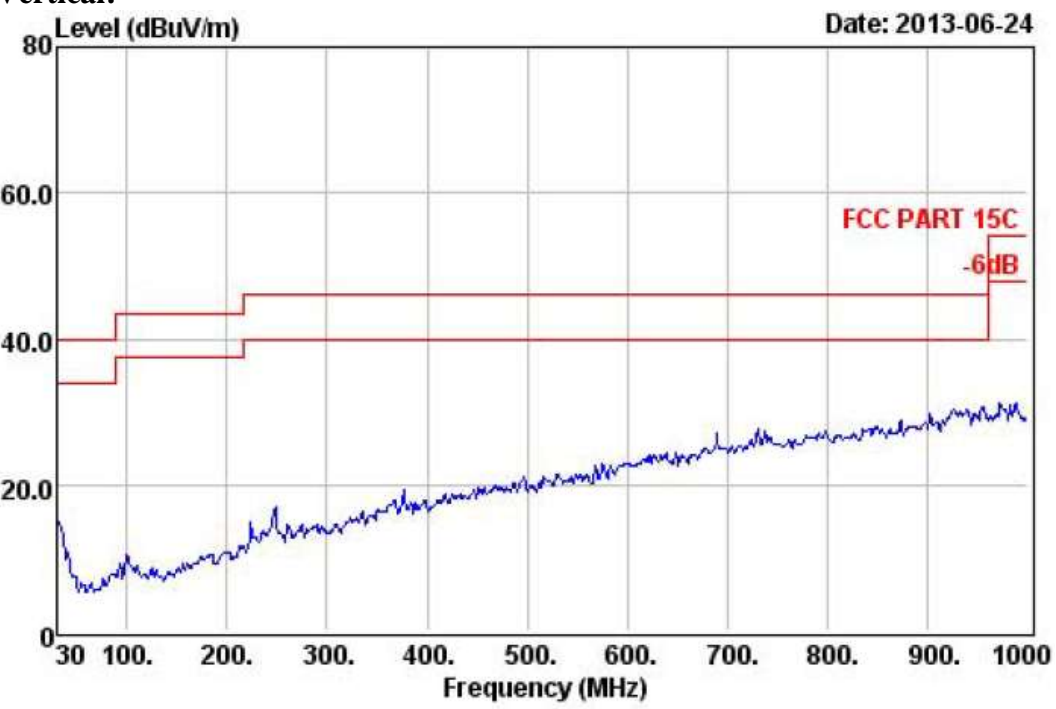

4.2.7 Measurement uncertainty

Uncertainty: 3.2 dB at a level of confidence of 95%