

S

T

S

L

A

B



RADIO TEST REPORT

Report No.: STS2204200W05

Issued for

Trackimo INC.

450 Seventh Avenue, Suite 1408, New York, United States

Product Name:	NickWatch V1
Brand Name:	Trackimo
Model Name:	TRKNICK001
Series Model:	N/A
FCC ID:	2AAI6-TRKNICK001
Test Standard:	FCC Part 22H and 24E

Any reproduction of this document must be done in full. No single part of this document may be reproduced without permission from STS, all test data presented in this report is only applicable to presented test sample.

Shenzhen STS Test Services Co., Ltd.
A 1/F, Building B, Zhuoke Science Park, No.190 Chongqing Road, HepingShequ,
Fuyong Sub-District, Bao'an District, Shenzhen, Guang Dong, China
TEL: +86-755 3688 6288 FAX: +86-755 3688 6277 E-mail: sts@stsapp.com





TEST RESULT CERTIFICATION

Applicant's Name: Trackimo INC.
Address: 450 Seventh Avenue, Suite 1408, New York, United States
Manufacturer's Name: Trackimo INC.
Address: 450 Seventh Avenue, Suite 1408, New York, United States

Product Description

Product Name: NickWatch V1
Brand Name: Trackimo
Model Name: TRKNICK001
Series Model: N/A
Test Standards: FCC Part 22H and 24E
Test Procedure: KDB 971168 D01 v03r01,ANSI C63.26(2015)

This device described above has been tested by STS, the test results show that the equipment under test (EUT) is in compliance with the FCC requirements. And it is applicable only to the tested sample identified in the report.
This report shall not be reproduced except in full, without the written approval of STS, this document may be altered or revised by STS, personal only, and shall be noted in the revision of the document..

Date of Test.....:
Date of receipt of test item.....: 27 Apr. 2022
Date (s) of performance of tests.: 27 Apr. 2022 ~ 10 June 2022
Date of Issue: 10 June 2022
Test Result: Pass

Testing Engineer : [Signature]
(Chris Chen)

Technical Manager : [Signature]
(Sean she)

Authorized Signatory : [Signature]
(Bovey Yang)





Table of Contents	Page
1 INTRODUCTION	6
1.1 TEST FACTORY	6
1.2 MEASUREMENT UNCERTAINTY	6
2 PRODUCT INFORMATION	7
3 TEST CONFIGURATION OF EQUIPMENT UNDER TEST	9
4 MEASUREMENT INSTRUMENTS	10
5 TEST ITEMS	11
5.1 CONDUCTED OUTPUT POWER&TRANSMITTER RADIATED POWER	11
5.2 PEAK TO AVERAGE RATIO	12
5.4 FREQUENCY STABILITY	13
5.5 SPURIOUS EMISSIONS AT ANTENNA TERMINALS	18
5.6 BAND EDGE	19
5.7 FIELD STRENGTH OF SPURIOUS RADIATION MEASUREMENT	20
APPENDIX-PHOTOS OF TEST SETUP	34

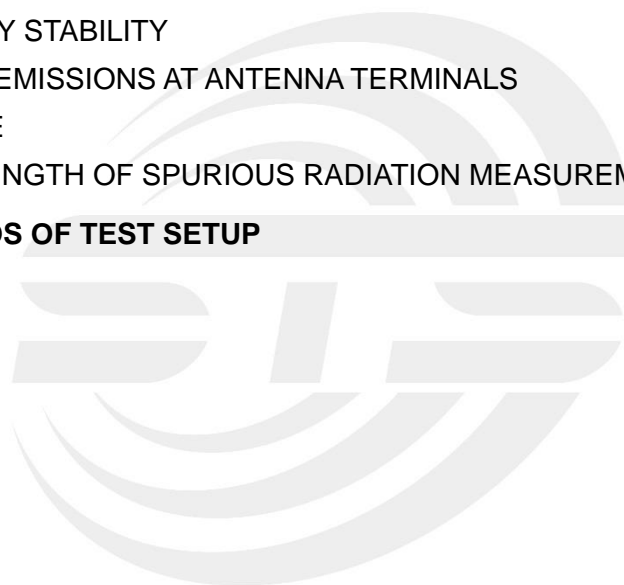



Revision History

Rev.	Issue Date	Report NO.	Effect Page	Contents
00	10 June 2022	STS2204200W05	ALL	Initial Issue





SUMMARY OF TEST RESULTS

Test procedures according to the technical standards:

The radiated emission testing was performed according to the procedures of KDB 971168 D01 v03r01 and ANSI C63.26(2015)

FCC Rules	Test Description	Test Limit	Test Result	Reference
2.1046	Conducted Output Power	Reporting Only	PASS	
22.913d 24.232d	Peak-to-Average Ratio	< 13 dB	PASS	
2.1046 22.913 24.232	Effective Radiated Power/Equivalent Isotropic Radiated Power	< 7 Watts max. ERP(Part 22) < 2 Watts max. EIRP(Part 24)	PASS	
2.1049 22.917 24.238	Occupied Bandwidth	Reporting Only	PASS	
2.1055 22.355 24.235	Frequency Stability	< 2.5 ppm (Part 22) Emission must remain in band (Part 24)	PASS	
2.1051 22.917 24.238	Spurious Emission at Antenna Terminals	< 43+10log ₁₀ (P[Watts])	PASS	
2.1053 22.917 24.238	Field Strength of Spurious Radiation	< 43+10log ₁₀ (P[Watts])	PASS	
2.1051 22.917 24.238	Band Edge	< 43+10log ₁₀ (P[Watts])	PASS	



1 INTRODUCTION

1.1 TEST FACTORY

SHENZHEN STS TEST SERVICES CO., LTD

Add. : A 1/F, Building B, Zhuoke Science Park, No.190 Chongqing Road, HepingShequ, Fuyong Sub-District, Bao'an District, Shenzhen, Guang Dong, China

FCC test Firm Registration Number: 625569

IC test Firm Registration Number: 12108A

A2LA Certificate No.: 4338.01

1.2 MEASUREMENT UNCERTAINTY

The measurement uncertainties shown below were calculated in accordance with the requirements of ANSI C63.4-2014. All measurement uncertainty values are shown with a coverage factor of $k = 2$ to indicate a 95% level of confidence. The measurement data shown herein meets or exceeds the CISPR measurement uncertainty values specified in CISPR 16-4-2 and, thus, can be compared directly to specified limits to determine compliance.

No.	Item	Uncertainty
1	RF output power, conducted	± 0.87 dB
2	Unwanted Emissions, conducted	± 2.895 dB
3	All emissions, radiated 9K-30MHz	± 3.80 dB
4	All emissions, radiated 30M-1GHz	± 4.09 dB
5	All emissions, radiated 1G-6GHz	± 4.92 dB
6	All emissions, radiated >6G	± 5.49 dB
7	Conducted Emission (9KHz-30MHz)	± 2.73 dB



2 PRODUCT INFORMATION

Product Name	NickWatch V1
Trade Name	Trackimo
Model Name	TRKNICK001
Series Model	N/A
Model Difference	N/A
Tx Frequency:	GSM/GPRS/EDGE: 850: 824 MHz ~ 849MHz 1900: 1850 MHz ~ 1910MHz WCDMA: Band V: 824 MHz ~ 849 MHz Band II: 1850 MHz ~ 1910 MHz
Rx Frequency:	GSM/GPRS/EDGE: 850: 869 MHz ~ 894 MHz 1900: 1930 MHz ~ 1990MHz WCDMA: Band V: 869 MHz ~ 894 MHz Band II: 1930 MHz ~ 1990 MHz
Max RF Output Power:	GSM850:31.20dBm, PCS1900:31.05dBm GPRS850(1-Slot):31.07dBm, GPRS1900(1-Slot):31.15dBm GPRS850(2-Slot):30.07dBm, GPRS1900(2-Slot):30.11dBm GPRS850(3-Slot):28.09dBm, GPRS1900(3-Slot):27.98dBm GPRS850(4-Slot):27.29dBm, GPRS1900(4-Slot):27.19dBm EDGE 850(1-Slot):25.70dBm, EDGE 1900(1-Slot):29.80dBm EDGE 850(2-Slot):24.70dBm, EDGE 1900(2-Slot):28.66dBm EDGE 850(3-Slot):22.81dBm, EDGE 1900(3-Slot):26.68dBm EDGE 850(4-Slot):21.34dBm, EDGE 1900(4-Slot):25.83dBm WCDMA Band V:22.55dBm, WCDMA Band II:22.59dBm
Type of Emission:	GSM(850): 248KGXW; PCS(1900): 246KGXW GPRS(850): 252KGXW; GPRS(1900): 248KGXW EDGE(850): 250KG7W; EDGE(1900): 258KG7W WCDMA850: 4M18F9W WCDMA1900: 4M18F9W
Modulation Characteristics:	GMSK for GSM/GPRS; GMSK and 8PSK for EDGE WCDMA: QPSK; HSDPA:QPSK/16QAM; HSUPA:BPSK
SIM Card:	Only support single SIM Card.
Antenna:	PIFA
Antenna gain:	GSM 850/PCS 1900: -4.5dBi, WCDMA 850/1900: -3.4dBi,
Battery parameter:	Rated Voltage:3.85V Charge Limit Voltage:4.4V Capacity: 460mAh
Adapter:	Vertical charging stand: Input: DC 5V 1A Output: DC 5V 500mA Round charging stand: Output: DC 5V 500mA
GPRS/EDGE Class:	Multi-Class12
Extreme Vol. Limits:	DC 3.35V~ DC 4.35V(Normal: DC 3.85V)



Extreme Temp. Tolerance:	-30°C to +50°C
Hardware version number:	UW02 AUO V0.3
Software version number:	0.2
<i>** Note: The High Voltage 4.35V and Low Voltage 3.35V was declared by manufacturer, The EUT couldn't be operate normally with higher or lower voltage, the antenna information refer the manufacturer provide report, applicable only to the tested sample identified in the report.</i>	





3 TEST CONFIGURATION OF EQUIPMENT UNDER TEST

Antenna port conducted and radiated test items were performed according to KDB 971168 D01 and ANSI C63.26 2015 Power Meas. License Digital Systems with maximum output power.

Radiated measurements were performed with rotating EUT in different three orthogonal test planes to find the maximum emission.

Radiated emissions were investigated as following frequency range:

1. 30 MHz to 10th harmonic for GSM850 and WCDMA Band V.
2. 30 MHz to 10th harmonic for GSM1900 and WCDMA Band II.

All modes and data rates and positions were investigated.

Test modes are chosen to be reported as the worst case configuration below:

BAND	TEST MODES	
	RADIATED TCS	CONDUCTED TCS
GSM 850	GSM LINK GPRS/EDGE CLASS 12 LINK	GSM LINK GPRS/EDGE CLASS 12 LINK
GSM 1900	GSM LINK GPRS/EDGE CLASS 12 LINK	GSM LINK GPRS/EDGE CLASS 12 LINK
WCDMA BAND V	RMC 12.2KBPS LINK	RMC 12.2KBPS LINK
WCDMA BAND II	RMC 12.2KBPS LINK	RMC 12.2KBPS LINK



4 MEASUREMENT INSTRUMENTS

Radiation Test equipment

Kind of Equipment	Manufacturer	Type No.	Serial No.	Last calibration	Calibrated until
Test Receiver	R&S	ESCI	101427	2021.09.30	2022.09.29
Signal Analyzer	R&S	FSV 40-N	101823	2021.09.30	2022.09.29
Signal Generator	Agilent	83752A	3610A02740	2021.09.30	2022.09.29
Wireless Communications Test Set	R&S	CMW 500	131428	2022.03.01	2023.02.28
Bilog Antenna	TESEQ	CBL6111D	34678	2020.10.12	2022.10.11
Horn Antenna	SCHWARZBECK	BBHA 9120D	02014	2021.10.11	2023.10.10
Bilog Antenna	TESEQ	CBL6111D	45873	2020.10.12	2022.10.11
Horn Antenna	SCHWARZBECK	BBHA 9120D	9120D-1343	2020.10.12	2022.10.11
SHF-EHF Horn Antenna (18G-40GHz)	A-INFO	LB-180400-KF	J211020657	2020.10.12	2022.10.11
Pre-Amplifier (0.1M-3GHz)	EM	EM330	060665	2021.10.08	2022.10.07
Pre-Amplifier (1G-18GHz)	SKET	LNPA-01018G-45	SK2018080901	2021.09.30	2022.09.29
Pre-Amplifier (18G-40GHz)	SKET	LNPA-1840-50	SK2018101801	2021.09.28	2022.09.27
Turn table	EM	SC100_1	60531	N/A	N/A
Antenna mast	EM	SC100	N/A	N/A	N/A
Temperature & Humidity	HH660	Mieo	N/A	2021.10.09	2022.10.08
Test SW	BALUN	BL410-E/18.905			

RF Connected Test

Kind of Equipment	Manufacturer	Type No.	Serial No.	Last calibration	Calibrated until
Universal Radio communication tester	R&S	CMU200	111058	2021.09.29	2022.09.28
Wireless Communications Test Set	R&S	CMW 500	131428	2022.03.01	2023.02.28
Signal Analyzer	Agilent	N9020A	MY52440124	2022.03.01	2023.02.28
Temperature & Humidity test chamber	Safety test	AG80L	171200018	2022.03.01	2023.02.28
Programmable power supply	Agilent	E3642A	MY40002025	2021.10.08	2022.10.07
Temperature & Humidity	SW-108	SuWei	N/A	2022.03.02	2023.03.01
Test SW	FARAD	LZ-RF /LzRf-3A3			

Equipment with a calibration date of "NCR" shown in this list was not used to make direct calibrated measurements.

5 TEST ITEMS

5.1 CONDUCTED OUTPUT POWER&TRANSMITTER RADIATED POWER

TEST OVERVIEW

CONDUCTED OUTPUT POWER:

A system simulator was used to establish communication with the EUT. Its parameters were set to enforce EUT transmitting at the maximum power. The measured power in the radio frequency on the transmitter output terminals shall be reported.

TRANSMITTER RADIATED POWER (EIRP/ERP)

Determining ERP and/or EIRP from conducted RF output power measurements according to ANSI C63.26 2015 Section 5.2.5.5.

In many cases, RF output power limits are specified in terms of the ERP or the EIRP. Typically, ERP is specified when the operating frequency is less than or equal to 1 GHz and EIRP is specified when the operating frequency is greater than 1 GHz. Both are defined as the product of the power supplied to the antenna and its gain (relative to a dipole antenna in the case of ERP, and relative to an isotropic antenna in the case of EIRP); however, when working in decibels (i.e., logarithmic scale), the ERP and EIRP represent the sum of the transmit antenna gain (in dBd or dBi, respectively) and the conducted RF output power (expressed in dB relative to watts or milliwatts). The relevant equation for determining the maximum ERP or EIRP from the measured RF output power is given in Equation (1) as follows:

$$(1) \text{ ERP or EIRP} = P_{\text{Meas}} + GT$$

$$\text{ERP} = \text{EIRP} - 2.15$$

where

ERP or EIRP effective radiated power or equivalent isotropically radiated power, respectively (expressed in the same units as P_{Meas} , e.g., dBm or dBW)

P_{Meas} measured transmitter output power or PSD, in dBm or dBW

GT gain of the transmitting antenna, in dBd (ERP) or dBi (EIRP)

For devices utilizing multiple antennas, see 6.4 for guidance with respect to determining the effective array transmit antenna gain term to be used in the above equation.

The following equations demonstrate the mathematical relationship between ERP and EIRP:

a) $\text{ERP} = \text{EIRP} - 2.15$, where ERP and EIRP are expressed in consistent units.

b) $\text{EIRP} = \text{ERP} + 2.15$, where ERP and EIRP are expressed in consistent units.

TEST PROCEDURES

1. The transmitter output port was connected to the system simulator.
2. Set eut at maximum power through the system simulator.
3. Select lowest, middle, and highest channels for each band and different modulation.
4. Measure and record the power level from the system simulator.

TEST SETUP

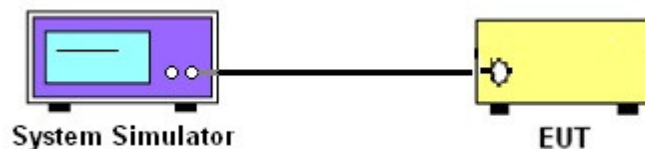

TEST RESULT

Note: The test data please reference to attachment “STS2204200W05_Appendix GSM” and “STS2204200W05_Appendix WCDMA”.

5.2 PEAK TO AVERAGE RATIO

TEST OVERVIEW

According to §24.232(d), power measurements for transmissions by stations authorized under this section may be made either in accordance with a commission-approved average power technique or in compliance with paragraph (e) of this section. In both instances, equipment employed must be authorized in accordance with the provisions of §24.51. In measuring transmissions in this band using an average power technique, the peak-to-average ratio (PAR) of the transmission may not exceed 13 db.

TEST PROCEDURES

1. The testing follows FCC KDB 971168 v03r01 section.
2. The eut was connected to the peak and av system simulator& spectrum analyzer.
3. Select lowest, middle, and highest channels for each band and different modulation.
4. Set the test probe and measure average power of the spectrum analysis,

TEST SETUP

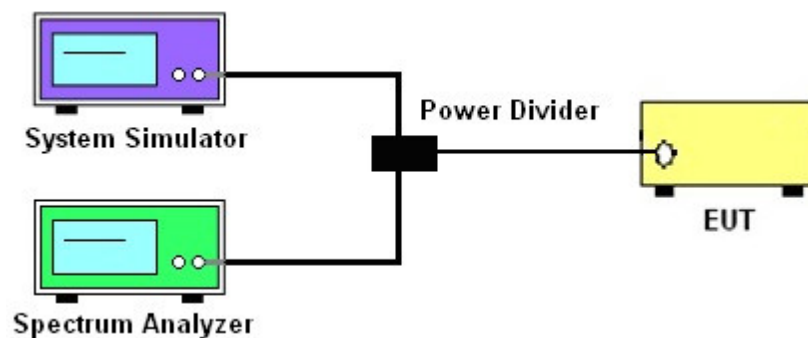

TEST RESULT

Note: The test data please reference to attachment “STS2204200W05_Appendix GSM” and “STS2204200W05_Appendix WCDMA”.

5.4 FREQUENCY STABILITY

TEST OVERVIEW

Frequency stability testing is performed in accordance with the guidelines of ANSI C63.26 2015.

The frequency stability of the transmitter is measured by:

- a.) Temperature: The temperature is varied from -30°C to $+50^{\circ}\text{C}$ in 10°C increments using an environmental chamber.
- b.) Primary Supply Voltage: The primary supply voltage is varied from 85% to 115% of the nominal value for non hand-carried battery and AC powered equipment. For hand-carried, battery-powered equipment, primary supply voltage is reduced to the battery operating end point which shall be specified by the manufacturer.

For Part 22, the frequency stability of the transmitter shall be maintained within $\pm 0.00025\%$ (± 2.5 ppm) of the center frequency. For Part 24 the frequency stability shall be sufficient to ensure that the fundamental emission stays within the authorized frequency block.

TEST PROCEDURE

Temperature Variation

1. The testing follows FCC KDB 971168 D01 section 9.0
2. The EUT was set up in the thermal chamber and connected with the system simulator.
3. With power OFF, the temperature was decreased to -30°C and the EUT was stabilized before testing. Power was applied and the maximum change in frequency was recorded within one minute.
4. With power OFF, the temperature was raised in 10°C steps up to 50°C . The EUT was stabilized at each step for at least half an hour. Power was applied and the maximum frequency change was recorded within one minute.

Voltage Variation

1. The testing follows FCC KDB 971168 D01 Section 9.0.
2. The EUT was placed in a temperature chamber at $25\pm 5^{\circ}\text{C}$ and connected with the system simulator.
3. The power supply voltage to the EUT was varied from 85% to 115% of the nominal value measured at the input to the EUT.
4. The variation in frequency was measured for the worst case.

TEST SETUP

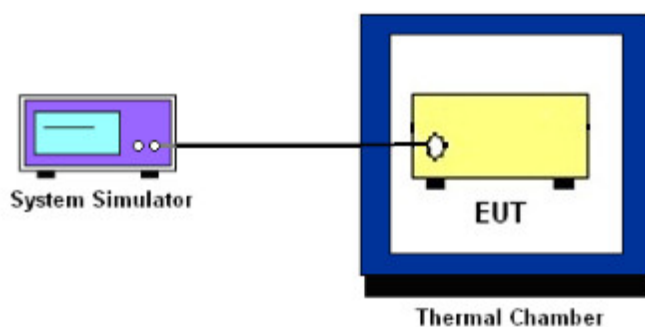



TEST RESULT

GSM 850 /836.6MHz					
Temperature (°C)	Voltage	Freq. Dev.	Freq. Dev.	Limit	Result
	(Volt)	(Hz)	(ppm)		
50	Normal Voltage	22.04	0.026	2.5ppm	PASS
40		32.14	0.038		
30		25.63	0.031		
20		21.57	0.026		
10		34.33	0.041		
0		34.70	0.041		
-10		19.89	0.024		
-20		34.72	0.042		
-30		33.08	0.040		
20		Maximum Voltage	28.62		
20	BEP	27.70	0.033		

GPRS 850 /836.6MHz					
Temperature (°C)	Voltage	Freq. Dev.	Freq. Dev.	Limit	Result
	(Volt)	(Hz)	(ppm)		
50	Normal Voltage	20.61	0.025	2.5ppm	PASS
40		27.72	0.033		
30		14.92	0.018		
20		17.99	0.022		
10		27.09	0.032		
0		34.32	0.041		
-10		14.59	0.017		
-20		19.63	0.023		
-30		28.72	0.034		
20		Maximum Voltage	27.76		
20	BEP	24.05	0.029		

EGPRS 850 /836.6MHz					
Temperature (°C)	Voltage	Freq. Dev.	Freq. Dev.	Limit	Result
	(Volt)	(Hz)	(ppm)		
50	Normal Voltage	34.59	0.041	2.5ppm	PASS
40		17.93	0.021		
30		34.49	0.041		
20		27.24	0.033		
10		11.99	0.014		
0		22.87	0.027		
-10		12.64	0.015		
-20		15.43	0.018		
-30		24.29	0.029		
20		Maximum Voltage	19.39		
20	BEP	32.86	0.039		



GSM 1900 / 1880MHz					
Temperature (°C)	Voltage	Freq. Dev.	Freq. Dev.	Limit	Result
	(Volt)	(Hz)	(ppm)		
50	Normal Voltage	31.43	0.017	Within Authorized Band	PASS
40		18.30	0.010		
30		15.16	0.008		
20		35.44	0.019		
10		15.54	0.008		
0		25.77	0.014		
-10		29.61	0.016		
-20		18.12	0.010		
-30		24.04	0.013		
20		Maximum Voltage	34.06		
20	BEP	34.82	0.019		

GPRS 1900 / 1880MHz					
Temperature (°C)	Voltage	Freq. Dev.	Freq. Dev.	Limit	Result
	(Volt)	(Hz)	(ppm)		
50	Normal Voltage	23.61	0.013	Within Authorized Band	PASS
40		28.82	0.015		
30		26.16	0.014		
20		23.47	0.012		
10		34.57	0.018		
0		30.84	0.016		
-10		19.18	0.010		
-20		15.09	0.008		
-30		21.26	0.011		
20		Maximum Voltage	15.80		
20	BEP	17.26	0.009		

EGPRS 1900 / 1880MHz					
Temperature (°C)	Voltage	Freq. Dev.	Freq. Dev.	Limit	Result
	(Volt)	(Hz)	(ppm)		
50	Normal Voltage	30.78	0.016	Within Authorized Band	PASS
40		30.68	0.016		
30		19.61	0.010		
20		25.13	0.013		
10		32.65	0.017		
0		15.52	0.008		
-10		28.62	0.015		
-20		13.66	0.007		
-30		13.56	0.007		
20		Maximum Voltage	35.22		
20	BEP	12.79	0.007		



UMTS Band 2 /1880MHz					
Temperature (°C)	Voltage	Freq. Dev.	Freq. Dev.	Limit	Result
	(Volt)	(Hz)	(ppm)		
50	Normal Voltage	29.98	0.016	Within Authorized Band	PASS
40		31.27	0.017		
30		18.26	0.010		
20		19.15	0.010		
10		14.22	0.008		
0		31.82	0.017		
-10		17.55	0.009		
-20		20.84	0.011		
-30		14.52	0.008		
20		Maximum Voltage	17.04		
20	BEP	22.30	0.012		

HSDPA Band 2 /1880MHz					
Temperature (°C)	Voltage	Freq. Dev.	Freq. Dev.	Limit	Result
	(Volt)	(Hz)	(ppm)		
50	Normal Voltage	21.32	0.011	Within Authorized Band	PASS
40		33.41	0.018		
30		36.34	0.019		
20		26.10	0.014		
10		31.20	0.017		
0		32.59	0.017		
-10		17.28	0.009		
-20		33.89	0.018		
-30		20.40	0.011		
20		Maximum Voltage	30.80		
20	BEP	16.45	0.009		

HSUPA Band 2 /1880MHz					
Temperature (°C)	Voltage	Freq. Dev.	Freq. Dev.	Limit	Result
	(Volt)	(Hz)	(ppm)		
50	Normal Voltage	26.37	0.014	Within Authorized Band	PASS
40		15.72	0.008		
30		21.96	0.012		
20		25.14	0.013		
10		14.93	0.008		
0		31.39	0.017		
-10		12.51	0.007		
-20		13.20	0.007		
-30		17.39	0.009		
20		Maximum Voltage	12.47		
20	BEP	11.64	0.006		



UMTS Band 5 / 836.6MHz					
Temperature (°C)	Voltage	Freq. Dev.	Freq. Dev.	Limit	Result
	(Volt)	(Hz)	(ppm)		
50	Normal Voltage	25.97	0.031	2.5ppm	PASS
40		19.16	0.023		
30		20.64	0.025		
20		14.25	0.017		
10		17.59	0.021		
0		29.39	0.035		
-10		26.08	0.031		
-20		30.64	0.037		
-30		31.81	0.038		
20		Maximum Voltage	17.57		
20	BEP	15.79	0.019		

HSDPA Band 5 / 836.6MHz					
Temperature (°C)	Voltage	Freq. Dev.	Freq. Dev.	Limit	Result
	(Volt)		(ppm)		
50	Normal Voltage	22.42	0.027	2.5ppm	PASS
40		34.77	0.042		
30		31.30	0.037		
20		19.76	0.024		
10		12.64	0.015		
0		11.62	0.014		
-10		29.81	0.036		
-20		36.24	0.043		
-30		17.95	0.021		
20		Maximum Voltage	29.52		
20	BEP	17.22	0.021		

HSUPA Band 5 / 836.6MHz					
Temperature (°C)	Voltage	Freq. Dev.	Freq. Dev.	Limit	Result
	(Volt)	(Hz)	(ppm)		
50	Normal Voltage	29.21	0.035	2.5ppm	PASS
40		19.62	0.023		
30		35.69	0.043		
20		19.83	0.024		
10		12.02	0.014		
0		28.42	0.034		
-10		30.62	0.037		
-20		31.27	0.037		
-30		18.27	0.022		
20		Maximum Voltage	17.37		
20	BEP	12.26	0.015		

5.5 SPURIOUS EMISSIONS AT ANTENNA TERMINALS

TEST OVERVIEW

The power of any emission outside of the authorized operating frequency ranges must be lower than the transmitter power (P) by a factor of at least $43 + 10 \log (P)$ dB.

It is measured by means of a calibrated spectrum analyzer and scanned from 30 MHz up to a frequency including its 10th harmonic.

TEST PROCEDURE

1. The testing FCC KDB 971168 D01 v03r01 Section 6.0. and ANSI C63.26-2015-Section 5.7.
2. The EUT was connected to the spectrum analyzer and system simulator via a power divider.
3. The RF output of EUT was connected to the spectrum analyzer by an RF cable and attenuator. The path loss was compensated to the results for each measurement.
4. The middle channel for the highest RF power within the transmitting frequency was measured.
5. The conducted spurious emission for the whole frequency range was taken.
6. The RF fundamental frequency should be excluded against the limit line in the operating frequency band.

7. The limit line is derived from $43 + 10\log(P)$ dB below the transmitter power P(Watts)

$$= P(W) - [43 + 10\log(P)] \text{ (dB)}$$

$$= [30 + 10\log(P)] \text{ (dBm)} - [43 + 10\log(P)] \text{ (dB)}$$

$$= -13\text{dBm.}$$

TEST SETUP

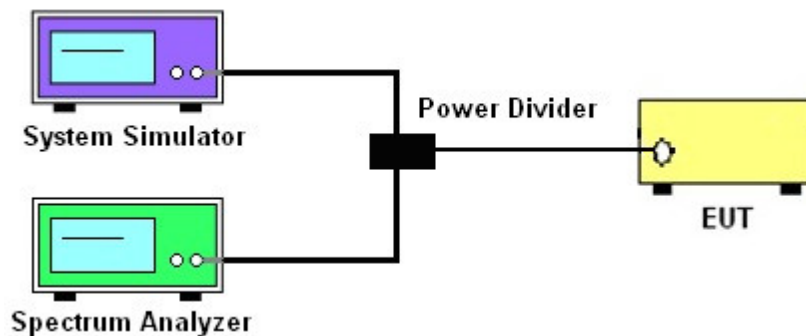

TEST RESULT

Note: The test data please reference to attachment “STS2204200W05_Appendix GSM” and “STS2204200W05_Appendix WCDMA”.

5.6 BAND EDGE

TEST OVERVIEW

All out of band emissions are measured with a spectrum analyzer connected to the antenna terminal of the EUT while the EUT is operating at maximum power, and at the appropriate frequencies. All data rates were investigated to determine the worst case configuration. All modes of operation were investigated and the worst case configuration results are reported in this section.

The minimum permissible attenuation level of any spurious emission is $43 + \log_{10}(P[\text{Watts}])$, where P is the transmitter power in Watts.

TEST PROCEDURE

1. The testing FCC KDB 971168 D01 v03r01 Section 6.0 and ANSI C63.26-2015-Section 5.7
2. Start and stop frequency were set such that the band edge would be placed in the center of the Plot.
3. The EUT was connected to the spectrum analyzer and system simulator via a power divider.
4. The RF output of EUT was connected to the spectrum analyzer by an RF cable and attenuator. The path loss was compensated to the results for each measurement.
5. The band edges of low and high channels for the highest RF powers were measured.
6. The RF fundamental frequency should be excluded against the limit line in the operating frequency band.

7. The limit line is derived from $43 + 10\log(P)$ dB below the transmitter power P(Watts)
 $= P(W) - [43 + 10\log(P)]$ (dB)
 $= [30 + 10\log(P)]$ (dBm) - $[43 + 10\log(P)]$ (dB)
 $= -13\text{dBm}$.

TEST SETUP

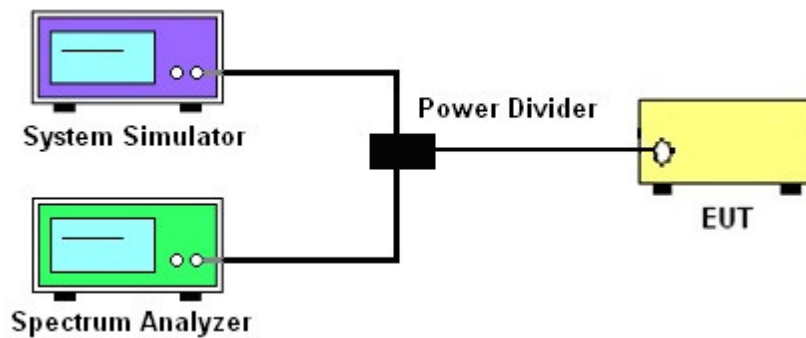

TEST RESULT

Note: The test data please reference to attachment “STS2204200W05_Appendix GSM” and “STS2204200W05_Appendix WCDMA”.



5.7 FIELD STRENGTH OF SPURIOUS RADIATION MEASUREMENT

TEST OVERVIEW

Radiated spurious emissions measurements are performed using the substitution method described in ANSI C63.26-2015 with the EUT transmitting into an integral antenna. Measurements on signals operating below 1GHz are performed using horizontally and vertically polarized tuned dipole antennas. Measurements on signals operating above 1GHz are performed using vertically and horizontally polarized horn antennas. All measurements are performed as peak measurements while the EUT is operating at maximum power and at the appropriate frequencies.

It is measured by means of a calibrated spectrum analyzer and scanned from 30 MHz up to a frequency including its 10th harmonic.

TEST PROCEDURE

1. The testing FCC KDB 971168 D01 Section 5.8 and ANSI C63.26-2015-Section 5.5.
2. RBW = 100kHz for emissions below 1GHz and 1MHz for emissions above 1GHz
3. VBW $\geq 3 \times$ RBW
4. Span = 1.5 times the OBW
5. No. of sweep points $> 2 \times$ span/RBW
6. Detector = Peak
7. Trace mode = max hold
8. The trace was allowed to stabilize
9. Effective Isotropic Spurious Radiation was measured by substitution method according to TIA/EIA-603-D. The EUT was replaced by the substitution antenna at same location, and then a known power from S.G. was applied into the dipole antenna through a Tx cable, and then recorded the maximum Analyzer reading through raised and lowered the test antenna.
 $P_{Mea} = S.G \text{ Level} + \text{Ant-Cable loss}$; $\text{Margin} = P_{Mea} - \text{Limit}$.

TEST SETUP

For radiated test from 30MHz to 1GHz

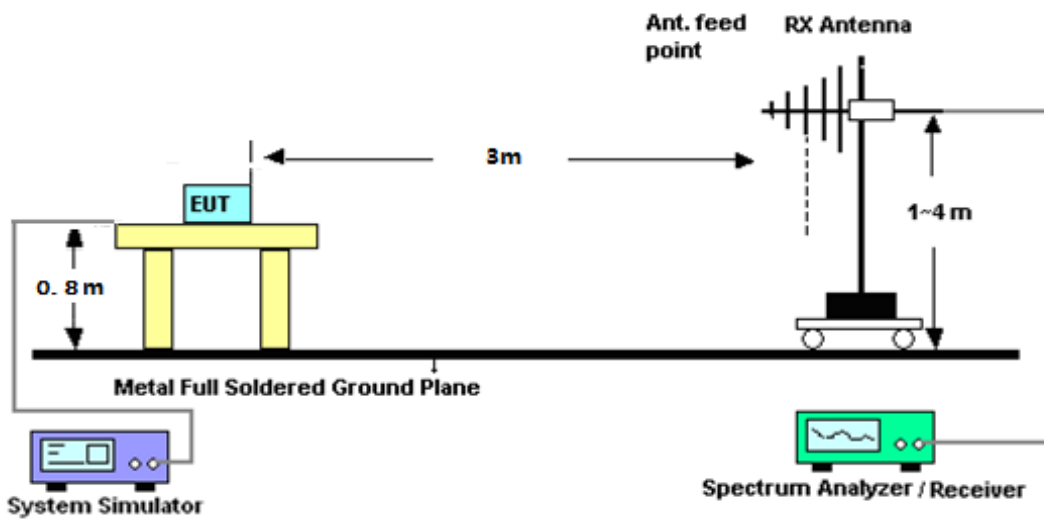

For radiated test from above 1GHz

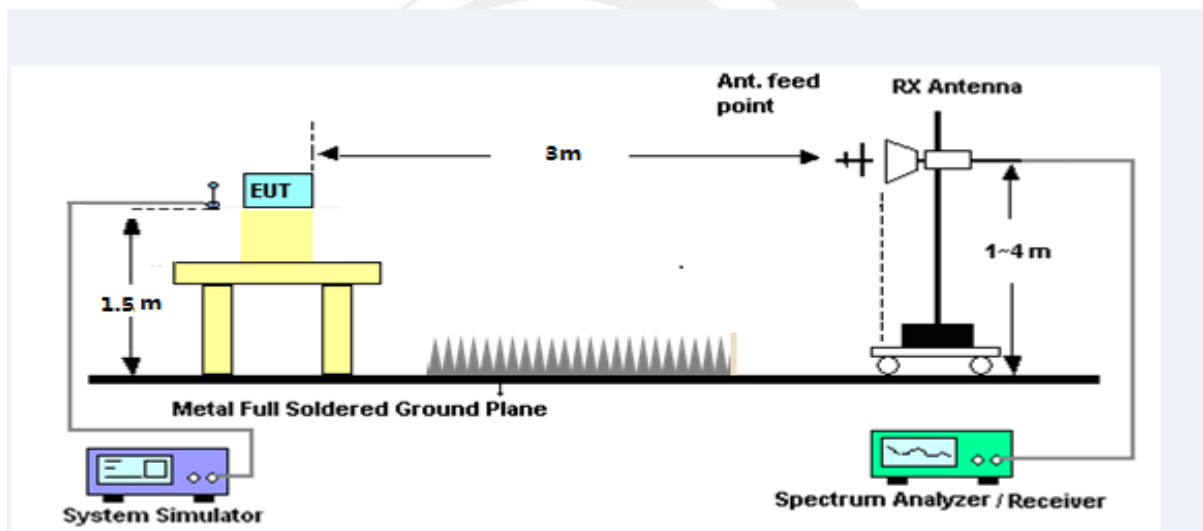

TEST RESULT

Note: (1) Spurious emissions which are attenuated by more than 20dB below the permissible value for frequency below 1000MHz.

(2) Above 3.5GHz amplitude of spurious emissions which are attenuated by more than 20dB below the permissible value

(3) Test is divided into three directions, X/Y/Z. X pattern for the worst.

GSM 850: (30-9000)MHz							
The Worst Test Results Channel 128/824.2 MHz							
Frequency(MHz)	S G.Lev (dBm)	Ant(dBi)	Loss	PMea	Limit	Margin	Polarity
				(dBm)	(dBm)	(dBm)	
1648.03	-41.54	9.40	4.75	-36.89	-13.00	-23.89	H
2472.48	-39.55	10.60	8.39	-37.34	-13.00	-24.34	H
3296.68	-32.01	12.00	11.79	-31.80	-13.00	-18.80	H
1648.14	-43.35	9.40	4.75	-38.70	-13.00	-25.70	V
2472.50	-44.02	10.60	8.39	-41.81	-13.00	-28.81	V
3296.49	-42.70	12.00	11.79	-42.49	-13.00	-29.49	V
The Worst Test Results Channel 190/836.6 MHz							
Frequency(MHz)	S G.Lev (dBm)	Ant(dBi)	Loss	PMea	Limit	Margin	Polarity
				(dBm)	(dBm)	(dBm)	
1673.01	-41.13	9.50	4.76	-36.39	-13.00	-23.39	H
2509.58	-40.29	10.70	8.40	-37.99	-13.00	-24.99	H
3346.02	-31.53	12.20	11.80	-31.13	-13.00	-18.13	H
1672.83	-43.84	9.40	4.75	-39.19	-13.00	-26.19	V
2509.45	-44.53	10.60	8.39	-42.32	-13.00	-29.32	V
3346.23	-43.58	12.20	11.82	-43.20	-13.00	-30.20	V
The Worst Test Results Channel 251/848.8 MHz							
Frequency(MHz)	S G.Lev (dBm)	Ant(dBi)	Loss	PMea	Limit	Margin	Polarity
				(dBm)	(dBm)	(dBm)	
1697.64	-40.75	9.60	4.77	-35.92	-13.00	-22.92	H
2546.56	-39.35	10.80	8.50	-37.05	-13.00	-24.05	H
3395.22	-32.05	12.50	11.90	-31.45	-13.00	-18.45	H
1697.35	-44.38	9.60	4.77	-39.55	-13.00	-26.55	V
2546.15	-44.92	10.80	8.50	-42.62	-13.00	-29.62	V
3395.10	-43.40	12.50	11.90	-42.80	-13.00	-29.80	V



GPRS 850: (30-9000)MHz							
The Worst Test Results Channel 128/824.2 MHz							
Frequency(MHz)	S	Ant(dBi)	Loss	PMea	Limit	Margin	Polarity
	G.Lev (dBm)			(dBm)	(dBm)	(dBm)	
1648.23	-41.18	9.40	4.75	-36.53	-13.00	-23.53	H
2472.63	-39.41	10.60	8.39	-37.20	-13.00	-24.20	H
3296.76	-31.79	12.00	11.79	-31.58	-13.00	-18.58	H
1648.50	-44.06	9.40	4.75	-39.41	-13.00	-26.41	V
2472.54	-43.95	10.60	8.39	-41.74	-13.00	-28.74	V
3296.87	-43.09	12.00	11.79	-42.88	-13.00	-29.88	V
The Worst Test Results Channel 190/836.6 MHz							
Frequency(MHz)	S	Ant(dBi)	Loss	PMea	Limit	Margin	Polarity
	G.Lev (dBm)			(dBm)	(dBm)	(dBm)	
1672.95	-40.96	9.50	4.76	-36.22	-13.00	-23.22	H
2509.74	-39.35	10.70	8.40	-37.05	-13.00	-24.05	H
3346.19	-32.11	12.20	11.80	-31.71	-13.00	-18.71	H
1673.03	-44.34	9.40	4.75	-39.69	-13.00	-26.69	V
2509.80	-45.25	10.60	8.39	-43.04	-13.00	-30.04	V
3346.07	-43.02	12.20	11.82	-42.64	-13.00	-29.64	V
The Worst Test Results Channel 251/848.8 MHz							
Frequency(MHz)	S	Ant(dBi)	Loss	PMea	Limit	Margin	Polarity
	G.Lev (dBm)			(dBm)	(dBm)	(dBm)	
1697.50	-40.21	9.60	4.77	-35.38	-13.00	-22.38	H
2546.21	-39.82	10.80	8.50	-37.52	-13.00	-24.52	H
3395.13	-31.15	12.50	11.90	-30.55	-13.00	-17.55	H
1697.67	-43.96	9.60	4.77	-39.13	-13.00	-26.13	V
2546.27	-44.99	10.80	8.50	-42.69	-13.00	-29.69	V
3395.19	-42.85	12.50	11.90	-42.25	-13.00	-29.25	V



EGPRS 850: (30-9000)MHz							
The Worst Test Results Channel 128/824.2 MHz							
Frequency(MHz)	S G.Lev (dBm)	Ant(dBi)	Loss	PMea	Limit	Margin	Polarity
				(dBm)	(dBm)	(dBm)	
1648.43	-41.04	9.40	4.75	-36.39	-13.00	-23.39	H
2472.25	-40.05	10.60	8.39	-37.84	-13.00	-24.84	H
3296.57	-31.18	12.00	11.79	-30.97	-13.00	-17.97	H
1648.43	-44.59	9.40	4.75	-39.94	-13.00	-26.94	V
2472.60	-45.45	10.60	8.39	-43.24	-13.00	-30.24	V
3296.68	-43.27	12.00	11.79	-43.06	-13.00	-30.06	V
The Worst Test Results Channel 190/836.6 MHz							
Frequency(MHz)	S G.Lev (dBm)	Ant(dBi)	Loss	PMea	Limit	Margin	Polarity
				(dBm)	(dBm)	(dBm)	
1673.20	-40.92	9.50	4.76	-36.18	-13.00	-23.18	H
2509.84	-39.75	10.70	8.40	-37.45	-13.00	-24.45	H
3346.14	-31.38	12.20	11.80	-30.98	-13.00	-17.98	H
1673.04	-44.15	9.40	4.75	-39.50	-13.00	-26.50	V
2509.77	-44.85	10.60	8.39	-42.64	-13.00	-29.64	V
3346.16	-42.69	12.20	11.82	-42.31	-13.00	-29.31	V
The Worst Test Results Channel 251/848.8 MHz							
Frequency(MHz)	S G.Lev (dBm)	Ant(dBi)	Loss	PMea	Limit	Margin	Polarity
				(dBm)	(dBm)	(dBm)	
1697.64	-41.28	9.60	4.77	-36.45	-13.00	-23.45	H
2546.17	-39.98	10.80	8.50	-37.68	-13.00	-24.68	H
3395.16	-31.29	12.50	11.90	-30.69	-13.00	-17.69	H
1697.50	-43.90	9.60	4.77	-39.07	-13.00	-26.07	V
2546.09	-45.29	10.80	8.50	-42.99	-13.00	-29.99	V
3395.18	-43.94	12.50	11.90	-43.34	-13.00	-30.34	V



DCS 1900: (30-20000)MHz							
The Worst Test Results for Channel 512/1850.2MHz							
Frequency(MHz)	S	Ant(dBi)	Loss	PMea	Limit	Margin	Polarity
	G.Lev (dBm)			(dBm)	(dBm)	(dBm)	
3700.48	-34.29	12.60	12.93	-34.62	-13.00	-21.62	H
5550.21	-34.32	13.10	17.11	-38.33	-13.00	-25.33	H
7400.62	-33.39	11.50	22.20	-44.09	-13.00	-31.09	H
3700.45	-34.62	12.60	12.93	-34.95	-13.00	-21.95	V
5550.69	-34.74	13.10	17.11	-38.75	-13.00	-25.75	V
7400.67	-31.74	11.50	22.20	-42.44	-13.00	-29.44	V
The Worst Test Results for Channel 661/1880.0MHz							
Frequency(MHz)	S	Ant(dBi)	Loss	PMea	Limit	Margin	Polarity
	G.Lev (dBm)			(dBm)	(dBm)	(dBm)	
3760.17	-34.13	12.60	12.93	-34.46	-13.00	-21.46	H
5640.14	-34.66	13.10	17.11	-38.67	-13.00	-25.67	H
7520.03	-32.28	11.50	22.20	-42.98	-13.00	-29.98	H
3760.18	-34.75	12.60	12.93	-35.08	-13.00	-22.08	V
5640.09	-34.94	13.10	17.11	-38.95	-13.00	-25.95	V
7520.11	-33.11	11.50	22.20	-43.81	-13.00	-30.81	V
The Worst Test Results for Channel 810/1909.8MHz							
Frequency(MHz)	S	Ant(dBi)	Loss	PMea	Limit	Margin	Polarity
	G.Lev (dBm)			(dBm)	(dBm)	(dBm)	
3819.62	-33.81	12.60	12.93	-34.14	-13.00	-21.14	H
5729.16	-34.62	13.10	17.11	-38.63	-13.00	-25.63	H
7639.19	-32.28	11.50	22.20	-42.98	-13.00	-29.98	H
3819.66	-34.75	12.60	12.93	-35.08	-13.00	-22.08	V
5729.09	-34.80	13.10	17.11	-38.81	-13.00	-25.81	V
7639.15	-31.77	11.50	22.20	-42.47	-13.00	-29.47	V



GPRS1900: (30-20000)MHz							
The Worst Test Results for Channel 512/1850.2MHz							
Frequency(MHz)	S G.Lev (dBm)	Ant(dBi)	Loss	PMea	Limit	Margin	Polarity
				(dBm)	(dBm)	(dBm)	
3700.19	-33.55	12.60	12.93	-33.88	-13.00	-20.88	H
5550.47	-34.85	13.10	17.11	-38.86	-13.00	-25.86	H
7400.55	-33.35	11.50	22.20	-44.05	-13.00	-31.05	H
3700.26	-35.73	12.60	12.93	-36.06	-13.00	-23.06	V
5550.43	-34.69	13.10	17.11	-38.70	-13.00	-25.70	V
7400.74	-33.08	11.50	22.20	-43.78	-13.00	-30.78	V
The Worst Test Results for Channel 661/1880.0MHz							
Frequency(MHz)	S G.Lev (dBm)	Ant(dBi)	Loss	PMea	Limit	Margin	Polarity
				(dBm)	(dBm)	(dBm)	
3759.79	-34.75	12.60	12.93	-35.08	-13.00	-22.08	H
5640.27	-34.17	13.10	17.11	-38.18	-13.00	-25.18	H
7520.05	-33.14	11.50	22.20	-43.84	-13.00	-30.84	H
3759.89	-35.75	12.60	12.93	-36.08	-13.00	-23.08	V
5640.14	-34.10	13.10	17.11	-38.11	-13.00	-25.11	V
7519.97	-32.58	11.50	22.20	-43.28	-13.00	-30.28	V
The Worst Test Results for Channel 810/1909.8MHz							
Frequency(MHz)	S G.Lev (dBm)	Ant(dBi)	Loss	PMea	Limit	Margin	Polarity
				(dBm)	(dBm)	(dBm)	
3819.33	-33.63	12.60	12.93	-33.96	-13.00	-20.96	H
5729.49	-34.18	13.10	17.11	-38.19	-13.00	-25.19	H
7639.21	-33.33	11.50	22.20	-44.03	-13.00	-31.03	H
3819.44	-34.71	12.60	12.93	-35.04	-13.00	-22.04	V
5729.29	-34.18	13.10	17.11	-38.19	-13.00	-25.19	V
7638.95	-32.24	11.50	22.20	-42.94	-13.00	-29.94	V



EGPRS 1900: (30-20000)MHz							
The Worst Test Results for Channel 512/1850.2MHz							
Frequency(MHz)	S G.Lev (dBm)	Ant(dBi)	Loss	PMea	Limit	Margin	Polarity
				(dBm)	(dBm)	(dBm)	
3700.23	-34.70	12.60	12.93	-35.03	-13.00	-22.03	H
5550.20	-34.20	13.10	17.11	-38.21	-13.00	-25.21	H
7400.50	-33.35	11.50	22.20	-44.05	-13.00	-31.05	H
3700.27	-35.91	12.60	12.93	-36.24	-13.00	-23.24	V
5550.60	-35.14	13.10	17.11	-39.15	-13.00	-26.15	V
7400.91	-32.85	11.50	22.20	-43.55	-13.00	-30.55	V
The Worst Test Results for Channel 661/1880.0MHz							
Frequency(MHz)	S G.Lev (dBm)	Ant(dBi)	Loss	PMea	Limit	Margin	Polarity
				(dBm)	(dBm)	(dBm)	
3759.82	-34.53	12.60	12.93	-34.86	-13.00	-21.86	H
5640.11	-35.16	13.10	17.11	-39.17	-13.00	-26.17	H
7519.84	-33.60	11.50	22.20	-44.30	-13.00	-31.30	H
3760.19	-35.04	12.60	12.93	-35.37	-13.00	-22.37	V
5640.00	-34.87	13.10	17.11	-38.88	-13.00	-25.88	V
7520.29	-31.91	11.50	22.20	-42.61	-13.00	-29.61	V
The Worst Test Results for Channel 810/1909.8MHz							
Frequency(MHz)	S G.Lev (dBm)	Ant(dBi)	Loss	PMea	Limit	Margin	Polarity
				(dBm)	(dBm)	(dBm)	
3819.70	-34.91	12.60	12.93	-35.24	-13.00	-22.24	H
5729.12	-34.61	13.10	17.11	-38.62	-13.00	-25.62	H
7639.11	-32.44	11.50	22.20	-43.14	-13.00	-30.14	H
3819.49	-35.20	12.60	12.93	-35.53	-13.00	-22.53	V
5729.22	-34.61	13.10	17.11	-38.62	-13.00	-25.62	V
7639.25	-32.16	11.50	22.20	-42.86	-13.00	-29.86	V



WCDMA Band 2: (30-20000)MHz							
The Worst Test Results for Channel 9262/1852.4MHz							
Frequency(MHz)	S	Ant(dBi)	Loss	PMea	Limit	Margin	Polarity
	G.Lev (dBm)			(dBm)	(dBm)	(dBm)	
3704.13	-34.02	12.60	12.93	-34.35	-13.00	-21.35	H
5557.59	-35.04	13.10	17.11	-39.05	-13.00	-26.05	H
7409.48	-32.79	11.50	22.20	-43.49	-13.00	-30.49	H
3704.09	-35.02	12.60	12.93	-35.35	-13.00	-22.35	V
5557.24	-34.07	13.10	17.11	-38.08	-13.00	-25.08	V
7409.49	-32.62	11.50	22.20	-43.32	-13.00	-30.32	V
The Worst Test Results for Channel 9400/1880MHz							
Frequency(MHz)	S	Ant(dBi)	Loss	PMea	Limit	Margin	Polarity
	G.Lev (dBm)			(dBm)	(dBm)	(dBm)	
3760.03	-34.02	12.60	12.93	-34.35	-13.00	-21.35	H
5639.80	-34.22	13.10	17.11	-38.23	-13.00	-25.23	H
7520.01	-32.18	11.50	22.20	-42.88	-13.00	-29.88	H
3759.88	-34.79	12.60	12.93	-35.12	-13.00	-22.12	V
5640.05	-33.98	13.10	17.11	-37.99	-13.00	-24.99	V
7520.23	-33.21	11.50	22.20	-43.91	-13.00	-30.91	V
The Worst Test Results for Channel 9538/1907.6MHz							
Frequency(MHz)	S	Ant(dBi)	Loss	PMea	Limit	Margin	Polarity
	G.Lev (dBm)			(dBm)	(dBm)	(dBm)	
3815.45	-33.87	12.60	12.93	-34.20	-13.00	-21.20	H
5722.38	-35.10	13.10	17.11	-39.11	-13.00	-26.11	H
7630.02	-32.16	11.50	22.20	-42.86	-13.00	-29.86	H
3815.38	-35.78	12.60	12.93	-36.11	-13.00	-23.11	V
5722.04	-34.75	13.10	17.11	-38.76	-13.00	-25.76	V
7629.90	-31.94	11.50	22.20	-42.64	-13.00	-29.64	V



HSUPA Band 2: (30-20000)MHz							
The Worst Test Results for Channel 9262/1852.4MHz							
Frequency(MHz)	S	Ant(dBi)	Loss	PMea	Limit	Margin	Polarity
	G.Lev (dBm)			(dBm)	(dBm)	(dBm)	
3704.38	-34.07	12.60	12.93	-34.40	-13.00	-21.40	H
5557.35	-34.94	13.10	17.11	-38.95	-13.00	-25.95	H
7409.46	-33.26	11.50	22.20	-43.96	-13.00	-30.96	H
3704.20	-35.55	12.60	12.93	-35.88	-13.00	-22.88	V
5557.26	-35.23	13.10	17.11	-39.24	-13.00	-26.24	V
7409.59	-32.27	11.50	22.20	-42.97	-13.00	-29.97	V
The Worst Test Results for Channel 9400/1880MHz							
Frequency(MHz)	S	Ant(dBi)	Loss	PMea	Limit	Margin	Polarity
	G.Lev (dBm)			(dBm)	(dBm)	(dBm)	
3760.22	-33.88	12.60	12.93	-34.21	-13.00	-21.21	H
5640.00	-34.99	13.10	17.11	-39.00	-13.00	-26.00	H
7520.18	-32.23	11.50	22.20	-42.93	-13.00	-29.93	H
3760.13	-35.10	12.60	12.93	-35.43	-13.00	-22.43	V
5640.16	-33.80	13.10	17.11	-37.81	-13.00	-24.81	V
7520.00	-31.96	11.50	22.20	-42.66	-13.00	-29.66	V
The Worst Test Results for Channel 9538/1907.6MHz							
Frequency(MHz)	S	Ant(dBi)	Loss	PMea	Limit	Margin	Polarity
	G.Lev (dBm)			(dBm)	(dBm)	(dBm)	
3815.53	-33.52	12.60	12.93	-33.85	-13.00	-20.85	H
5722.11	-34.09	13.10	17.11	-38.10	-13.00	-25.10	H
7630.15	-33.62	11.50	22.20	-44.32	-13.00	-31.32	H
3815.36	-35.40	12.60	12.93	-35.73	-13.00	-22.73	V
5722.33	-34.76	13.10	17.11	-38.77	-13.00	-25.77	V
7629.85	-32.69	11.50	22.20	-43.39	-13.00	-30.39	V



HSDPA Band 2: (30-20000)MHz							
The Worst Test Results for Channel 9262/1852.4MHz							
Frequency(MHz)	S G.Lev (dBm)	Ant(dBi)	Loss	PMea	Limit	Margin	Polarity
				(dBm)	(dBm)	(dBm)	
3704.02	-34.15	12.60	12.93	-34.48	-13.00	-21.48	H
5557.40	-34.36	13.10	17.11	-38.37	-13.00	-25.37	H
7409.59	-33.24	11.50	22.20	-43.94	-13.00	-30.94	H
3704.26	-35.66	12.60	12.93	-35.99	-13.00	-22.99	V
5557.50	-34.84	13.10	17.11	-38.85	-13.00	-25.85	V
7409.82	-32.60	11.50	22.20	-43.30	-13.00	-30.30	V
The Worst Test Results for Channel 9400/1880MHz							
Frequency(MHz)	S G.Lev (dBm)	Ant(dBi)	Loss	PMea	Limit	Margin	Polarity
				(dBm)	(dBm)	(dBm)	
3759.89	-34.78	12.60	12.93	-35.11	-13.00	-22.11	H
5640.03	-34.57	13.10	17.11	-38.58	-13.00	-25.58	H
7519.90	-32.94	11.50	22.20	-43.64	-13.00	-30.64	H
3760.19	-34.60	12.60	12.93	-34.93	-13.00	-21.93	V
5639.94	-34.62	13.10	17.11	-38.63	-13.00	-25.63	V
7520.28	-32.61	11.50	22.20	-43.31	-13.00	-30.31	V
The Worst Test Results for Channel 9538/1907.6MHz							
Frequency(MHz)	S G.Lev (dBm)	Ant(dBi)	Loss	PMea	Limit	Margin	Polarity
				(dBm)	(dBm)	(dBm)	
3815.71	-33.65	12.60	12.93	-33.98	-13.00	-20.98	H
5722.46	-35.35	13.10	17.11	-39.36	-13.00	-26.36	H
7630.17	-32.17	11.50	22.20	-42.87	-13.00	-29.87	H
3815.24	-35.77	12.60	12.93	-36.10	-13.00	-23.10	V
5722.26	-33.86	13.10	17.11	-37.87	-13.00	-24.87	V
7630.06	-33.08	11.50	22.20	-43.78	-13.00	-30.78	V



WCDMA Band 5: (30-9000)MHz							
The most testresults channel 4132/826.4MHz							
Frequency(MHz)	S	Ant(dBi)	Loss	PMea	Limit	Margin	Polarity
	G.Lev (dBm)			(dBm)	(dBm)	(dBm)	
1652.27	-40.51	9.40	4.75	-35.86	-13.00	-22.86	H
2479.44	-40.58	10.60	8.39	-38.37	-13.00	-25.37	H
3305.90	-31.12	12.00	11.79	-30.91	-13.00	-17.91	H
1652.02	-43.91	9.40	4.75	-39.26	-13.00	-26.26	V
2479.51	-45.32	10.60	8.39	-43.11	-13.00	-30.11	V
3305.63	-43.21	12.00	11.79	-43.00	-13.00	-30.00	V
The Worst Test Results Channel 4183/836.6MHz							
Frequency(MHz)	S	Ant(dBi)	Loss	PMea	Limit	Margin	Polarity
	G.Lev (dBm)			(dBm)	(dBm)	(dBm)	
1673.10	-40.94	9.40	4.75	-36.29	-13.00	-23.29	H
2509.44	-40.59	10.60	8.39	-38.38	-13.00	-25.38	H
3346.19	-32.31	12.00	11.79	-32.10	-13.00	-19.10	H
1672.83	-43.82	9.40	4.75	-39.17	-13.00	-26.17	V
2509.43	-45.28	10.60	8.39	-43.07	-13.00	-30.07	V
3346.37	-43.06	12.00	11.79	-42.85	-13.00	-29.85	V
The Worst Test Results Channel 4233/846.6MHz							
Frequency(MHz)	S	Ant(dBi)	Loss	PMea	Limit	Margin	Polarity
	G.Lev (dBm)			(dBm)	(dBm)	(dBm)	
1693.59	-41.06	9.40	4.75	-36.41	-13.00	-23.41	H
2539.42	-39.30	10.60	8.39	-37.09	-13.00	-24.09	H
3386.17	-31.14	12.00	11.79	-30.93	-13.00	-17.93	H
1693.24	-43.15	9.40	4.75	-38.50	-13.00	-25.50	V
2539.18	-44.18	10.60	8.39	-41.97	-13.00	-28.97	V
3386.12	-42.90	12.00	11.79	-42.69	-13.00	-29.69	V



HSUPA Band 5: (30-9000)MHz							
The most testresults channel 4132/826.4MHz							
Frequency(MHz)	S	Ant(dBi)	Loss	PMea	Limit	Margin	Polarity
	G.Lev (dBm)			(dBm)	(dBm)	(dBm)	
1652.27	-40.58	9.40	4.75	-35.93	-13.00	-22.93	H
2479.71	-40.43	10.60	8.39	-38.22	-13.00	-25.22	H
3305.59	-32.01	12.00	11.79	-31.80	-13.00	-18.80	H
1652.17	-44.06	9.40	4.75	-39.41	-13.00	-26.41	V
2479.47	-45.01	10.60	8.39	-42.80	-13.00	-29.80	V
3305.92	-42.94	12.00	11.79	-42.73	-13.00	-29.73	V
The Worst Test Results Channel 4183/836.6MHz							
Frequency(MHz)	S	Ant(dBi)	Loss	PMea	Limit	Margin	Polarity
	G.Lev (dBm)			(dBm)	(dBm)	(dBm)	
1672.89	-41.59	9.40	4.75	-36.94	-13.00	-23.94	H
2509.74	-39.69	10.60	8.39	-37.48	-13.00	-24.48	H
3346.18	-32.09	12.00	11.79	-31.88	-13.00	-18.88	H
1673.06	-43.81	9.40	4.75	-39.16	-13.00	-26.16	V
2509.43	-44.91	10.60	8.39	-42.70	-13.00	-29.70	V
3346.24	-42.93	12.00	11.79	-42.72	-13.00	-29.72	V
The Worst Test Results Channel 4233/846.6MHz							
Frequency(MHz)	S	Ant(dBi)	Loss	PMea	Limit	Margin	Polarity
	G.Lev (dBm)			(dBm)	(dBm)	(dBm)	
1693.50	-41.32	9.40	4.75	-36.67	-13.00	-23.67	H
2539.53	-40.32	10.60	8.39	-38.11	-13.00	-25.11	H
3386.11	-31.98	12.00	11.79	-31.77	-13.00	-18.77	H
1693.21	-43.62	9.40	4.75	-38.97	-13.00	-25.97	V
2539.42	-45.24	10.60	8.39	-43.03	-13.00	-30.03	V
3386.20	-42.84	12.00	11.79	-42.63	-13.00	-29.63	V



HSDPA Band 5: (30-9000)MHz							
The most testresults channel 4132/826.4MHz							
Frequency(MHz)	S	Ant(dBi)	Loss	PMea	Limit	Margin	Polarity
	G.Lev (dBm)			(dBm)	(dBm)	(dBm)	
1652.46	-40.48	9.40	4.75	-35.83	-13.00	-22.83	H
2479.27	-39.38	10.60	8.39	-37.17	-13.00	-24.17	H
3305.89	-32.23	12.00	11.79	-32.02	-13.00	-19.02	H
1652.44	-43.54	9.40	4.75	-38.89	-13.00	-25.89	V
2479.57	-44.15	10.60	8.39	-41.94	-13.00	-28.94	V
3305.69	-43.57	12.00	11.79	-43.36	-13.00	-30.36	V
The Worst Test Results Channel 4183/836.6MHz							
Frequency(MHz)	S	Ant(dBi)	Loss	PMea	Limit	Margin	Polarity
	G.Lev (dBm)			(dBm)	(dBm)	(dBm)	
1672.88	-41.12	9.40	4.75	-36.47	-13.00	-23.47	H
2509.49	-39.63	10.60	8.39	-37.42	-13.00	-24.42	H
3346.33	-31.12	12.00	11.79	-30.91	-13.00	-17.91	H
1673.25	-44.54	9.40	4.75	-39.89	-13.00	-26.89	V
2509.89	-45.35	10.60	8.39	-43.14	-13.00	-30.14	V
3345.95	-43.96	12.00	11.79	-43.75	-13.00	-30.75	V
The Worst Test Results Channel 4233/846.6MHz							
Frequency(MHz)	S	Ant(dBi)	Loss	PMea	Limit	Margin	Polarity
	G.Lev (dBm)			(dBm)	(dBm)	(dBm)	
1693.21	-40.76	9.40	4.75	-36.11	-13.00	-23.11	H
2539.20	-39.22	10.60	8.39	-37.01	-13.00	-24.01	H
3385.93	-31.94	12.00	11.79	-31.73	-13.00	-18.73	H
1693.36	-44.41	9.40	4.75	-39.76	-13.00	-26.76	V
2539.55	-44.66	10.60	8.39	-42.45	-13.00	-29.45	V
3386.18	-42.81	12.00	11.79	-42.60	-13.00	-29.60	V



APPENDIX-PHOTOS OF TEST SETUP

Note: See test photos in setup photo document for the actual connections between Product and support equipment.

*****END OF THE REPORT*****

