



**FCC 47 CFR PART 15 SUBPART C 15.247  
TEST REPORT  
FOR  
GPS Sport Watch**

Model : GoWatch X-PRO

Trade Name: GOLiFE

Issued to

GOYOURLIFE INC.

6F., No. 189, Xinhua 3rd Rd., Neihu Dist., Taipei City 114, Taiwan (R.O.C.)

Issued by

WH Technology Corp.



<b>Open Site</b>		<b>No.120, Ln. 5, Hudong St., Xizhi Dist., New Taipei City 221, Taiwan (R.O.C.)</b>
<b>EMC Test Site</b>	<b>Xizhi Office and Lab</b>	<b>4F., No.27-1, Ln. 169, Kangning St., Xizhi Dist., New Taipei City 221, Taiwan (R.O.C.)</b>
<b>Tel.: +886-7729-7707 Fax: +886-2- 8648-1311</b>		

*Note: This test refers exclusively to the test presented test model and sample. This report shall not be reproduced except in full, without the written approval of WH Technology Corp. This document may be altered or revised by WH Technology Corp. Personnel only, and shall be noted in the revision section of the document.*



## Contents

<b>PHOTOS OF EUT 1. General Information .....</b>	<b>3</b>
<b>2. Report of Measurements and Examinations .....</b>	<b>5</b>
2.1 List of Measurements and Examinations .....	5
<b>3. Test Configuration of Equipment under Test .....</b>	<b>6</b>
3.1 Description of the tested samples .....	6
3.2 Carrier Frequency of Channels .....	7
3.3 Test Mode and Test Software .....	8
3.4 TEST Methodology & General Test Procedures .....	9
3.5 Measurement Uncertainty .....	10
3.6 Description of the Support Equipments .....	10
<b>4. Test and measurement equipment .....</b>	<b>12</b>
4.1 calibration .....	12
4.2 equipment .....	12
<b>5. Antenna Requirements .....</b>	<b>14</b>
5.1 Standard Applicable .....	14
5.2 Antenna Construction and Directional Gain .....	14
<b>6. Test of Conducted Emission .....</b>	<b>15</b>
6.1 Test Limit .....	15
6.2 Test Procedures .....	15
6.3 Typical Test Setup .....	16
6.4 Test Result and Data .....	17
<b>7. Test of Radiated Emission .....</b>	<b>19</b>
7.1 Test Limit .....	19
7.2 Test Procedures .....	19
7.3 Typical Test Setup .....	20
7.4 Test Result and Data (9kHz ~ 30MHz) .....	21
7.5 Test Result and Data (30MHz ~ 1GHz, worst emissions found) .....	21
7.6 Test Result and Data (Above 1GHz) .....	23
<b>8. 6dB Bandwidth Measurement Data .....</b>	<b>29</b>
8.1 Test Limit .....	29
8.2 Test Procedures .....	29
8.3 Test Setup Layout .....	29
8.4 Test Result and Data .....	30
<b>9. Maximum Peak and Average Output Power .....</b>	<b>32</b>
9.1 Test Limit .....	32
9.2 Test Procedures .....	32
9.3 Test Setup Layout .....	32
9.4 Test Result and Data .....	33



---

<b>10. Power Spectral Density .....</b>	<b>34</b>
10.1 Test Limit .....	34
10.2 Test Procedures .....	34
10.3 Test Setup Layout .....	34
10.4 Test Result and Data .....	35
<b>11. Band Edges Measurement .....</b>	<b>37</b>
11.1 Test Limit .....	37
11.2 Test Procedure .....	37
11.3 Test Setup Layout .....	37
11.4 Test Result and Data .....	38
11.5 Restrict Band Emission Measurement Data .....	41
<b>12. Restricted Bands of Operation .....</b>	<b>43</b>
12.1 Labeling Requirement .....	43

**APPENDIX 1 PHOTOS OF TEST CONFIGURATION  
PHOTOS OF EUT**



## 1. General Information

**Applicant** : GOYOURLIFE INC.

**Address** : 6F., No. 189, Xinhua 3rd Rd., Neihu Dist., Taipei City 114, Taiwan (R.O.C.)

**Manufacturer** : Dongguan-Chou Chin Watch & Clock Co., Ltd

**Address** : No. 14, NingJiang Rd., Daning Village, Humen Town, Dongguan City, Guangdong Province, China

**EUT** : GPS Sport Watch

**Model Name** : GoWatch X-PRO

**Model Differences** : N/A

Is here with confirmed to comply with the requirements set out in the FCC Rules and Regulations Part 15 Subpart C and the measurement procedures were according to ANSI C63.4-2009. The said equipment in the configuration described in this report shows the maximum emission levels emanating from equipment are within the compliance requirements.

### FCC part 15 subpart C

Receipt Date : 06/08/2015

Final Test Date : 06/18/2015

**Tested By:**

**Reviewed by:**

Jun. 18, 2015

Jun. 18, 2015

**Date**

Alex Chou

**Date**

Ben Lu / Manager  
Designation Number: TW1083



## 2. Report of Measurements and Examinations

### 2.1 List of Measurements and Examinations

FCC Rule	Description of Test	Result
15.203	. Antenna Requirement	Pass
15.207	. Conducted Emission	Pass
15.209 15.247(d)	. Radiated Emission	Pass
15.247(a)(2)	. 6dB Bandwidth	Pass
15.247(b)	. Maximum Peak Output Power	Pass
15.247(d)	. 100kHz Bandwidth of Frequency Band Edges	Pass
15.247(e)	. Power Spectral Density	Pass
1.1307 1.1310 2.1091 2.1093	. RF Exposure Compliance	Pass



### 3. Test Configuration of Equipment under Test

#### 3.1 Description of the tested samples

EUT Name : GPS Sport Watch

Model Number : GoWatch X-PRO

FCCID : 2AA5BGLGWPRO

Receipt Date : 06/08/2015

Input Voltage :: 3.7Vdc From Li-ion Battery or 5Vdc From USB Port

Power From : Inside Outside  
Adaptor Battery AC Power Source DC Power Source  
Support Unit PC or NB

Operate Frequency : Refer to the channel list as described below (2.402 ~2.480 GHz)

Modulation Technique : GFSK

Number of Channels : 40

Channel spacing : N/A  2 MHz

Operating Mode : Simplex  Half Duplex

Antenna Type : Helix Antenna

Channel bandwidth : 2 MHz

Antenna gain : 1 dBi



### 3.2 Carrier Frequency of Channels

BLE

Channel	Frequency(MHz)	Channel	Frequency(MHz)
00	2402	20	2442
01	2404	21	2444
02	2406	22	2446
03	2408	23	2448
04	2410	24	2450
05	2412	25	2452
06	2414	26	2454
07	2416	27	2456
08	2418	28	2458
09	2420	29	2460
10	2422	30	2462
11	2424	31	2464
12	2426	32	2466
13	2428	33	2468
14	2430	34	2470
15	2432	35	2472
16	2434	36	2474
17	2436	37	2476
18	2438	38	2478
19	2440	39	2480



### **3.3 Test Mode and Test Software**

- a. During testing, the interface cables and equipment positions were varied according to ANSI C63.4.
- b. The complete test system included Notebook and EUT for RF test.
- c. Test Software: N/A
- d. New Battery was used for all testing and the worst radiated emission case from X,Y and Z axis evaluation was selected for testing.
- e. The following test modes were performed for test:
  - BLE: CH00: 2402MHz, CH19: 2440MHz, CH39: 2480MHz





### **3.4 TEST Methodology & General Test Procedures**

All testing as described bellowed were performed in accordance with ANSI C63.4:2009 and FCC CFR 47 Part 15 Subpart C.

#### **Conducted Emissions**

The EUT is placed on a wood table, which is at 0.8 m above ground plane acceding to clause 15.207 and requirements of ANSI C63.4:2009. Conducted emissions from the EUT measured in the frequency range between 0.15 MHz and 30MHz are using CISPR Quasi-Peak / Average detectors.

#### **Radiated Emissions**

The EUT is a placed on a turn table, which is 0.8 m above ground plane. The turntable was rotated through 360 degrees to determine the position of maximum emission level. The EUT is placed at 3m away from the receiving antenna, which varied from 1m to 4m to find out the highest emission. Each emission was to be maximized by changing the polarization of receiving antenna both horizontal and vertical.

- 1) Putting the EUT on the platform and turning on the EUT (on/off button on the bottom of the EUT).
- 2) Setting test channel described as "Channel setting and operating condition", and testing channel by channel.
- 3) For the maximum output power measurement, we followed the method of measurement KDB558074 D01.
- 4) For the spurious emission test based on ANSI(2009), at the frequency where below 1GHz used quasi-peak detector mode; where above 1GHz used the peak and average detector mode. IF the peak value may be under average limit, the average mode will not be performed.



### 3.5 Measurement Uncertainty

Measurement Item	Uncertainty
Radiated emission	±4.11dB
Peak Output Power(conducted)	±1.38dB
Peak Output Power(Radiated)	±1.70dB
Power Spectral Density	±1.39dB
Radiated emission(3m)	±4.11dB
Radiated emission(10m)	±3.89dB

### 3.6 Description of the Support Equipments

#### Setup Diagram

See test photographs attached in appendix 1 for the actual connections between EUT and support equipment.

#### Support Equipment

Peripherals Devices:

OUTSIDE SUPPORT EQUIPMENT							
No.	Equipment	Model	Serial No.	FCC ID/ BSMI ID	Trade name	Data Cable	Power Cord
1.	N/A	N/A	N/A	N/A	N/A	N/A	N/A
INSIDE SUPPORT EQUIPMENT							
No.	Equipment	Model	Serial No.	FCC ID/ BSMI ID	Trade name	Data Cable	Power Cord
1.	PCB	X-PRO V2.0 FR4	323-07000 7-003601- 00	N/A	N/A	N/A	N/A
2.	Li-ion Battery	CA422436 3.7VDC, 320mAh	N/A	N/A	Coslight Technology Internationa l Group Co., Ltd.	N/A	N/A

**Note:** All the above equipment /cable were placed in worse case position to maximize emission signals during emission test



**Grounding:** Grounding was in accordance with the manufacturer's requirement and conditions for the intended use.



## **4. Test and measurement equipment**

### **4.1 calibration**

The measuring equipment utilized to perform the tests documented in the report has been calibrated once a year or in accordance with the manufacturer's recommendations, and is traceable to recognized national standards.

### **4.2 equipment**

The following list contains measurement equipment used for testing. The equipment conforms to the requirement of CISPR 16-1, ANSI C63.2 and. Other required standards.

Calibration of all test and measurement, including any accessories that may effect such calibration, is checked frequently to ensure the accuracy. Adjustments are made and correction factors are applied in accordance with the instructions contained in the respective.



### list of test and measurement equipment

Test Site	Instrument	Manufacturer	Model No.	S/N	Next Cal. Date
Conduction	Receiver	R&S	ESHS10	830223/008	Nov. 23, 2015
	Spectrum Analyzer	ADVANTEST	R3261C	87120343	Mar. 18, 2016
	RF Cable	MIYAZAKI & Anritsu	RG58A0 & MP59B	M79094	Apr. 08, 2016
	L.I.S.N	Rolf Heine Hochfrequenztechnik	NNB-2/16z	98062	Jan. 16, 2016
	EMI Test Receiver	R&S	EAHS-10	1093.4495.03	Mar. 21, 2016
	Click Analyzer	Schaffner	DIA1512C	5218	Jun. 15, 2016
	Power Meter	Anritsu	ML2487A	6K00003893	Jul. 31, 2015
	High Accuracy Sensor	Anritsu	MA2444A	001295	Jul. 31, 2015
Radiation	Spectrum Analyzer	Nexl Future	NS-265	N05044006	Aug. 04, 2015
	30MHz~1GHz RF Cable	YEIDA WIRE CABLE	N/A	N/A	Jan. 18, 2016
	1GHz~18GHz RF Cable	EMCI	N/A	N/A	July 30, 2015
	Hron Antenna 1GHZ~18GHZ	COM-POWER	AH-118	10056	Mar. 12, 2016
	Antenna(30M-1G)	SCHWARZBECH	VULB 9161	4078	Jan. 16, 2016
	Pre-Amplifier	Schaffner	CPA-9232	1028	Jan. 20, 2016
	Preamplifier 1GHz~18GHz	EMCI	EMC051845	980108	Oct.08, 2015
	18G~26G RF Cable	YEIDA WIRE CABLE	N/A	N/A	July 30, 2015
	Hron Antenna 18G~26G	COM-Power	AH-826	081000	Mar. 21, 2016
	Preamplifier 18G~26G	MITEQ	30-5A	808329	May 28, 2016

**\*CALIBRATION INTERVAL OF INSTRUMENTS LISTED ABOVE IS ONE YEAR**



## **5. Antenna Requirements**

### **5.1 Standard Applicable**

For intentional device, according to FCC 47 CFR Section 15.203, an intentional radiator shall be designed to ensure that no antenna other than that furnished by the responsible party shall be used with the device.

And according to FCC 47 CFR Section 15.247 (b), if transmitting antennas of directional gain greater than 6dBi are used, the power shall be reduced by the amount in dB that the directional gain of the antenna exceeds 6dBi.

### **5.2 Antenna Construction and Directional Gain**

**BLE:**

Antenna Type: Helix Antenna

Antenna Gain: 1 dBi



## 6. Test of Conducted Emission

### 6.1 Test Limit

Conducted Emissions were measured from 150 kHz to 30 MHz with a bandwidth of 9 KHz on the 120 VAC power and return leads of the EUT according to the methods defined in ANSI C63.4-2009 Section 3.1. The EUT was placed on a nonmetallic stand in a shielded room 0.8 meters above the ground plane as shown in section 2.2. The interface cables and equipment positioning were varied within limits of reasonable applications to determine the position produced maximum conducted emissions.

Frequency (MHz)	Quasi Peak (dB $\mu$ V)	Average (dB $\mu$ V)
0.15 – 0.5	66-56*	56-46*
0.5 – 5.0	56	46
5.0 – 30.0	60	50

\*Decreases with the logarithm of the frequency.

### 6.2 Test Procedures

- a. The EUT was placed 0.4 meter from the conducting wall of the shielding room was kept at least 80 centimeters from any other grounded conducting surface.
- b. Connect EUT to the power mains through a line impedance stabilization network (LISN).
- c. All the support units are connecting to the other LISN.
- d. The LISN provides 50 ohm coupling impedance for the measuring instrument.
- e. The FCC states that a 50 ohm, 50 micro-Henry LISN should be used.
- f. Both sides of AC line were checked for maximum conducted interference.
- g. The frequency range from 150 kHz to 30 MHz was searched.
- h. Set the test-receiver system to Peak Detect Function and Specified Bandwidth with Maximum Hold Mode.



### 6.3 Typical Test Setup

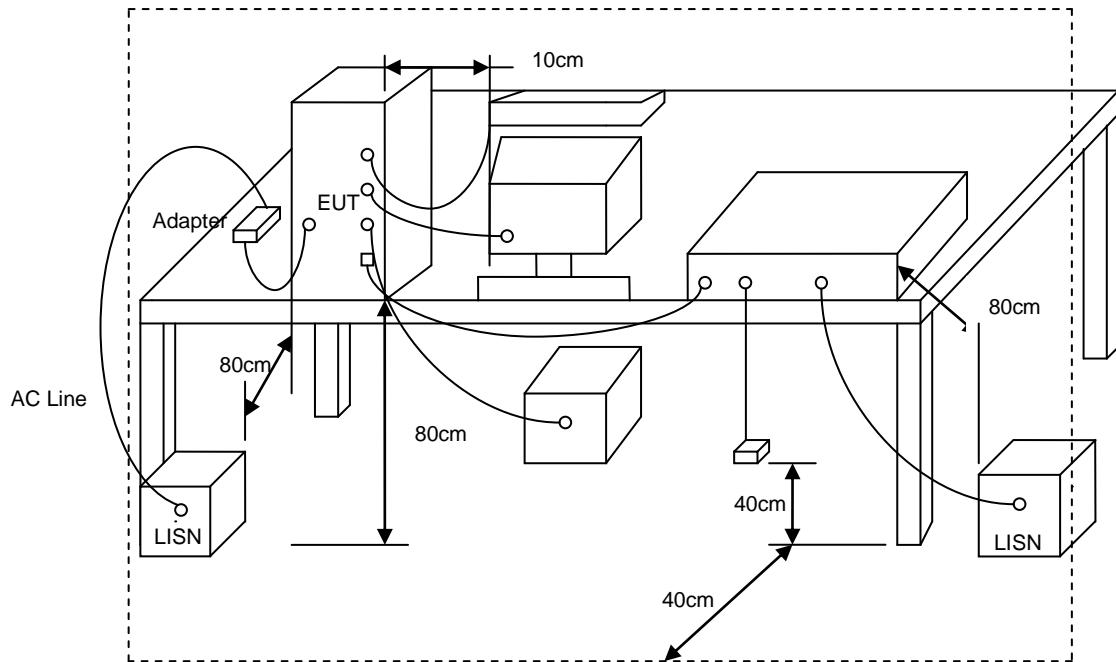





**6.4 Test Result and Data**

Power	: From System	Pol/Phase	: LINE
Test Mode 1	: GFSK, CH0	Temperature	: 25 °C
Test Date	: Jun. 17, 2015	Humidity	: 60 %
Memo	: X axis		

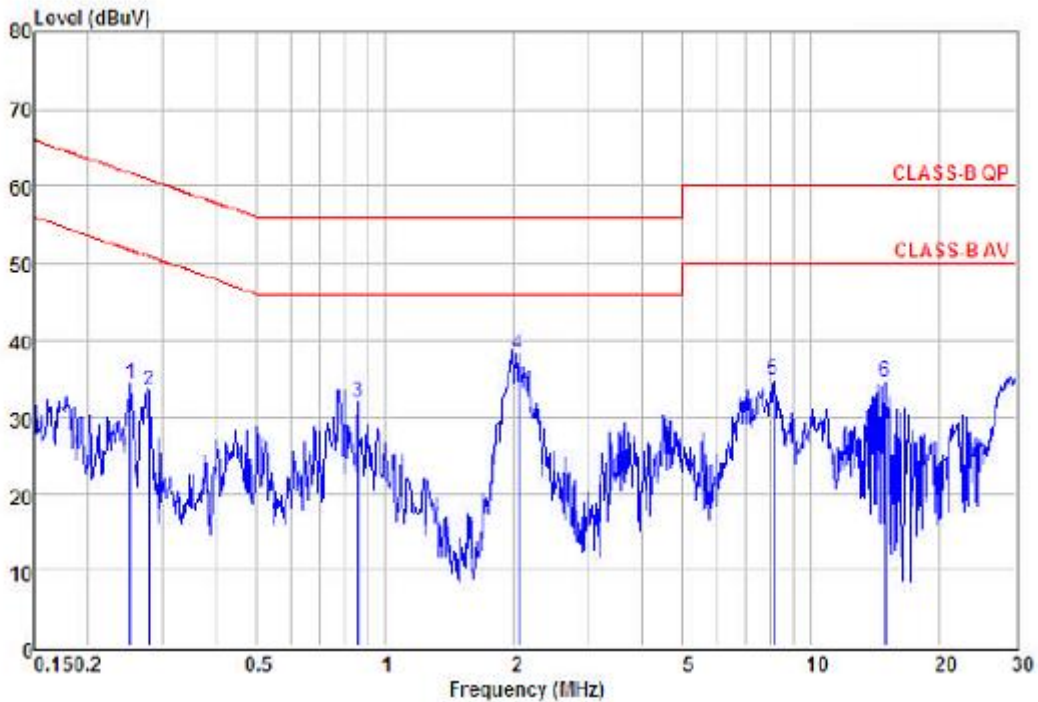

Site : Conduction  
 Condition : CLASS-B QP CON-LISN(103) LINE  
 EUT :  
 Power : From System  
 Mode : GFSK CH0  
 Temperature : 22  
 Humidity : 55  
 Memo : BLE

Remarks: : Factor=Insertion loss+Cable loss

	Freq	Read Level	Level Factor	Over Limit	Limit Line	Remark
	MHz	dBuV	dBuV	dB	dB	dBuV
1	0.25	33.91	34.25	0.34	-27.44	61.69 Peak
2	0.28	33.08	33.42	0.34	-27.43	60.85 Peak
3	0.86	31.53	31.91	0.38	-24.09	56.00 Peak
4	2.04	37.81	38.23	0.42	-17.77	56.00 Peak
5	8.11	34.20	34.77	0.57	-25.23	60.00 Peak
6	14.83	33.83	34.50	0.67	-25.50	60.00 Peak



Power	: From System	Pol/Phase	: NEUTRAL
Test Mode 1	: GFSK, CH0	Temperature	: 25 °C
Test Date	: Jun. 17, 2015	Humidity	: 60 %
Memo	: X axis		

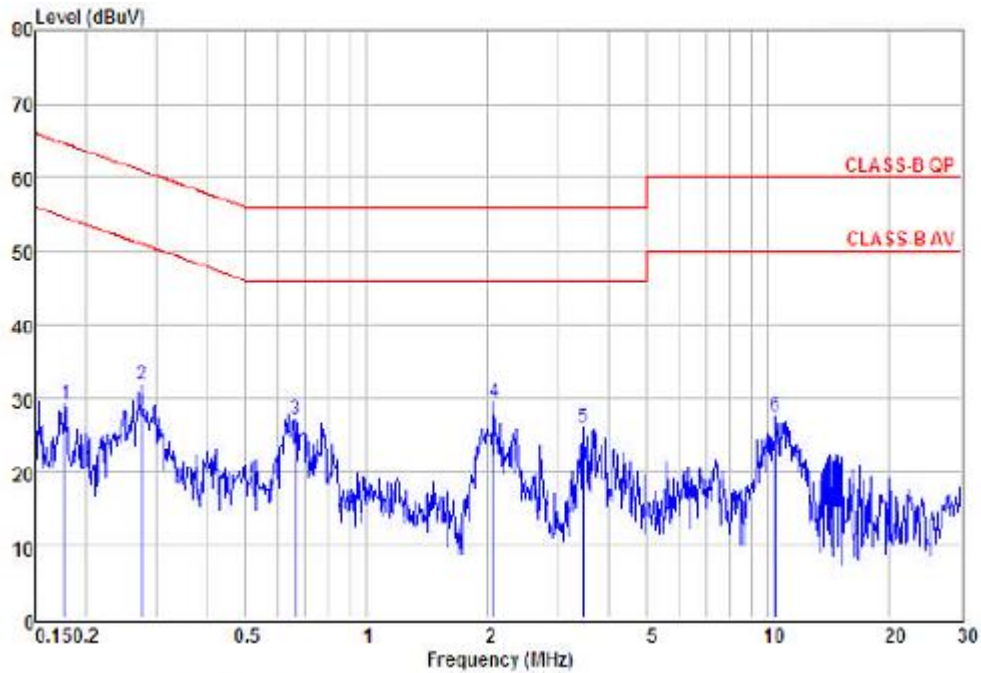

Site : Conduction  
 Condition : CLASS-B QP CON-LISN(103) NEUTRAL  
 EUT :  
 Power : From System  
 Mode : GFSK CH0  
 Temperature : 22  
 Humidity : 55  
 Memo : BLE

Remarks: : Factor=Insertion loss+Cable loss

	Freq	Read Level	Level Factor	Over Limit	Limit Line	Remark
	MHz	dBuV	dBuV	dB	dB	dBuV
1	0.18	28.72	29.10	0.38	-35.49	64.59 Peak
2	0.28	31.40	31.78	0.38	-29.16	60.94 Peak
3	0.66	26.62	27.02	0.40	-28.98	56.00 Peak
4	2.07	29.01	29.47	0.46	-26.53	56.00 Peak
5	3.45	25.41	25.91	0.50	-30.09	56.00 Peak
6	10.34	26.72	27.36	0.64	-32.64	60.00 Peak



## 7. Test of Radiated Emission

### 7.1 Test Limit

In any 100kHz bandwidth outside the frequency band in which the spread spectrum or digitally modulated intentional radiator is operating, the radio frequency power that is produced by the intentional radiator shall be at least 20dB below that in the 100kHz bandwidth within the band that contains the highest level of the desired power, based on either an RF conducted or a radiated measurement. If the transmitter measurement is based on the maximum conducted output power, the attenuation required under this paragraph shall be 30dB instead of 20dB. In addition, radiated emissions which fall in section 15.205(a) the restricted bands must also comply with the radiated emission limit specified in section 15.209(a).

Frequency (MHz)	Field Strength (microvolt/meter)	Measurement Distance (meters)
0.009 ~ 0.490	2400/F(kHz)	300
0.490 ~ 1.705	24000/F(kHz)	30
1.705 ~ 30.0	30	30
30 ~ 88	100	3
88 ~ 216	150	3
216 ~ 960	200	3
Above 960	500	3

### 7.2 Test Procedures

- a. The EUT was placed on a rotatable table top 0.8 meter above ground.
- b. The EUT was set 3 meters from the interference receiving antenna which was mounted on the top of a variable height antenna tower.
- c. The table was rotated 360 degrees to determine the position of the highest radiation.
- d. The antenna is a broadband antenna and its height is varied between one meter and four meters above ground to find the maximum value of the field strength both horizontal polarization and vertical polarization of the antenna are set to make the measurement.
- e. For each suspected emission the EUT was arranged to its worst case and then tune the antenna tower (from 1 M to 4 M) and turn table (from 0 degree to 360 degrees) to find the maximum reading.
- f. Set the test-receiver system to Peak or CISPR quasi-peak Detect Function and specified bandwidth with Maximum Hold Mode.
- g. If the emission level of the EUT in peak mode was 3 dB lower than the limit specified, then testing will be stopped and peak values of EUT will be reported, otherwise, the emissions which do not have 3 dB margin will be repeated one by one using the quasi-peak method and reported.
- h. For testing above 1GHz, the emission level of the EUT in peak mode was 20dB lower than average limit (that means the emission level in peak mode also complies with the limit in



average mode), then testing will be stopped and peak values of EUT will be reported, otherwise, the emissions will be measured in average mode again and reported.

- i. "Cone of radiation" has been considered to be 3dB bandwidth of the measurement antenna.

### 7.3 Typical Test Setup

For radiated emissions below 30MHz

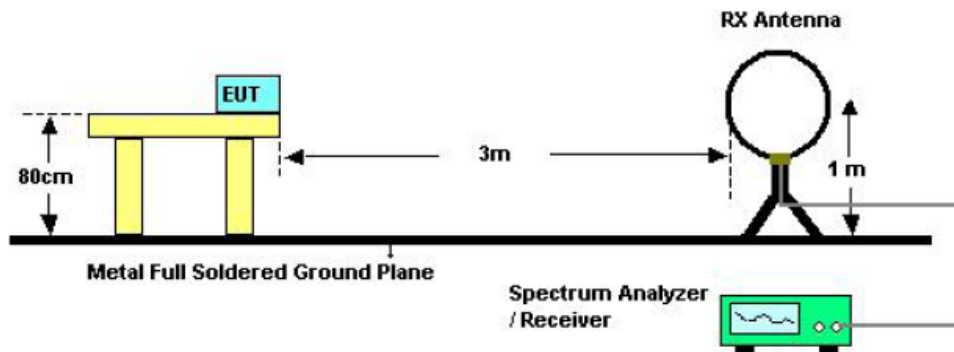

For radiated emissions above 30MHz

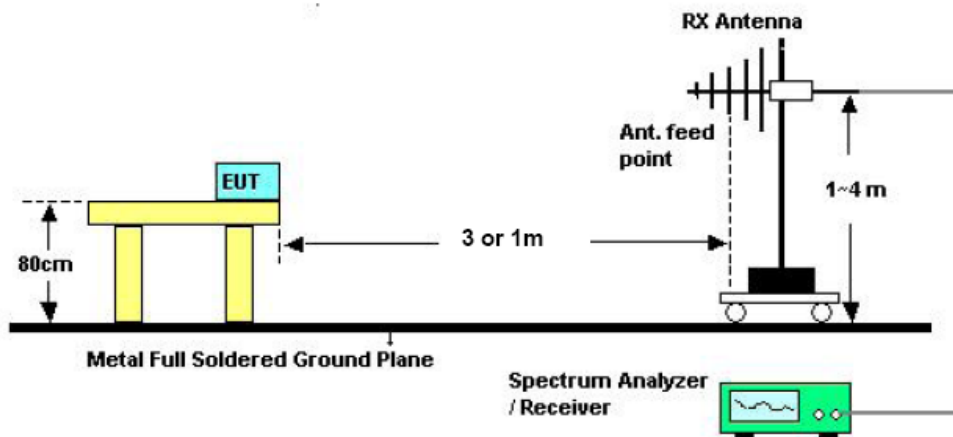

Above 10 GHz shall be extrapolated to the specified distance using an extrapolation factor of 20 dB/decade from 3m to 1m.

Distance extrapolation factor =  $20 \log (\text{specific distance [3m]} / \text{test distance [1m]})$  (dB);

Limit line = specific limits (dBuV) + distance extrapolation factor [9.54 dB].



**7.4 Test Result and Data (9kHz ~ 30MHz)**

The 9kHz - 30MHz spurious emission is under limit 20dB more.

**7.5 Test Result and Data (30MHz ~ 1GHz, worst emissions found)**

Power	: DC 3.7V	Pol/Phase	: VERTICAL
Test Mode 1	: GFSK, CH0	Temperature	: 28 °C
Memo	: X axis	Humidity	: 65 %

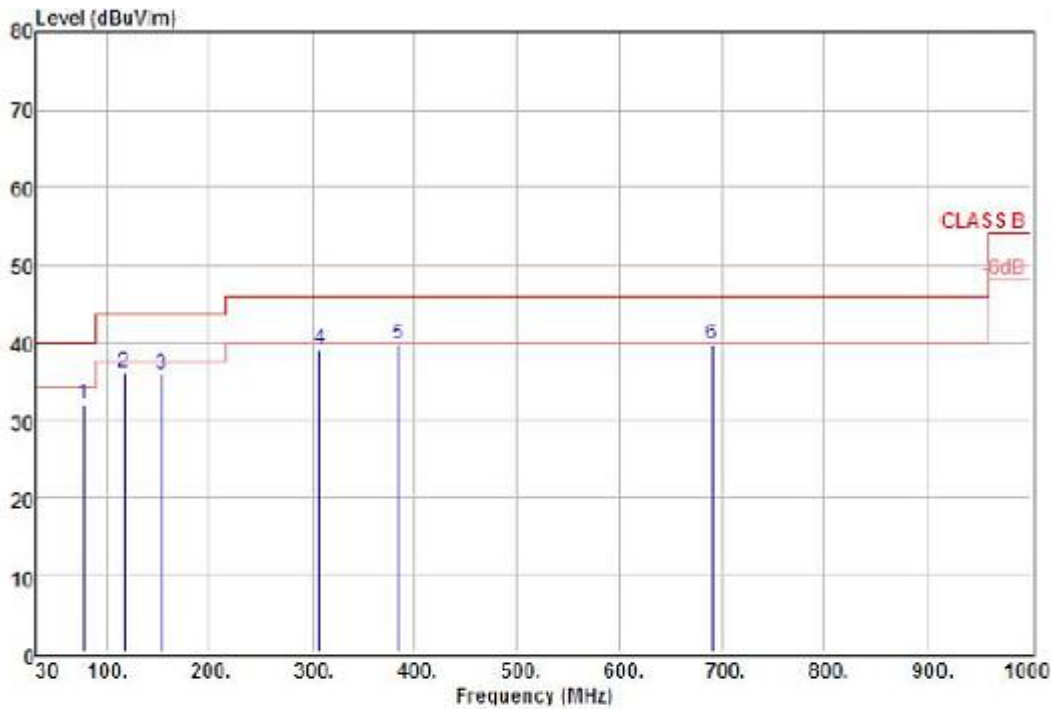

```

Site          : open site
Condition     : CLASS B 3m VULB9160(30-10)-104 VERTICAL
EUT          :
Power        : DC 3.7V
Node         : Transmit
Temperature   : 23
Humidity     : 65
Memo         : GFSK CH0
  
```

```

Remarks:
1.Result=Read Value+Factor
2.Factor=Antenna Factor+Cable loss-
Amplifier Factor
  
```

	Freq	Level	Read	Over	Limit	
	MHz	dBuV/m	Level	Factor	Limit	Line Remark
			dBuV	dB/m	dB	dBuV/m
1	76.77	31.94	51.09	-19.15	-8.06	40.00 QP
2	115.49	36.00	52.94	-16.94	-7.50	43.50 QP
3	153.48	35.76	50.30	-14.54	-7.74	43.50 QP
4	306.79	38.94	52.52	-13.58	-7.06	46.00 QP
5	384.55	39.59	51.25	-11.66	-6.41	46.00 QP
6	690.62	39.63	42.01	-2.38	-6.37	46.00 QP



Power	: DC 3.7V	Pol/Phase	: HORIZONTAL
Test Mode 1	: GFSK, CH0	Temperature	: 28 °C
Memo	: X axis	Humidity	: 65 %

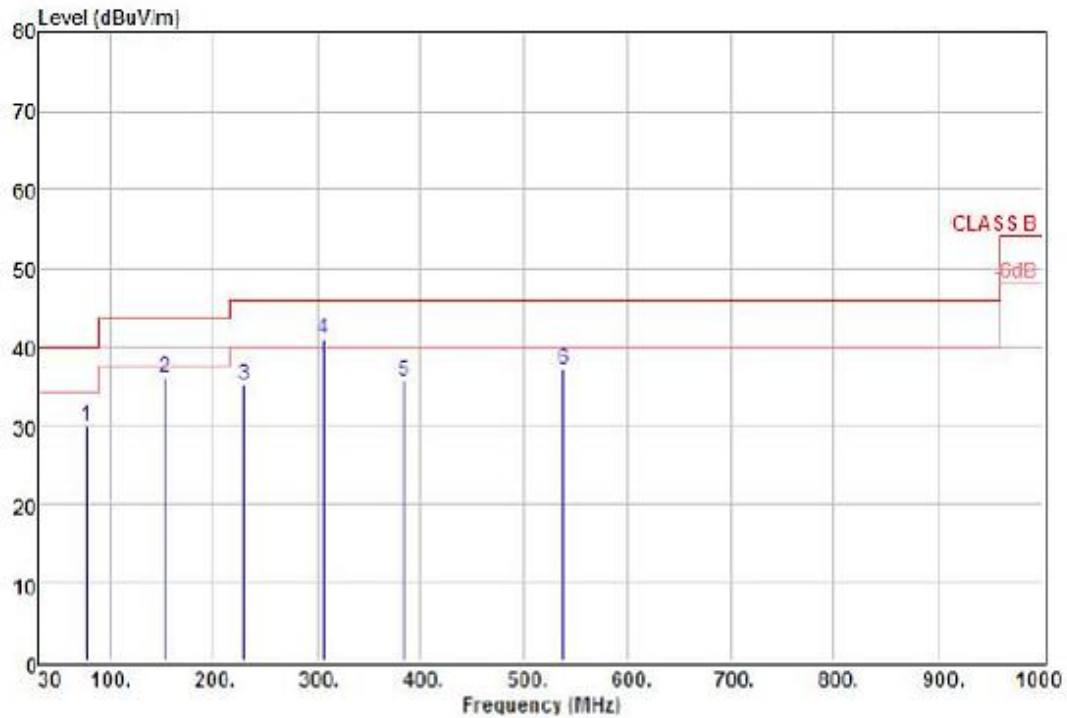

```

Site          : open site
Condition     : CLASS B 3m VULB9160(30-10)-104 HORIZONTAL
EUT          :
Power        : DC 3.7V
Mode         : Transmit
Temperature  : 23
Humidity     : 65
Memo         : GFSK CH0
  
```

```

Remarks:
: 1.Result=Read Value+Factor
: 2.Factor=Antenna Factor+Cable loss-
: Amplifier Factor
  
```

	Freq	Level	Read	Over	Limit	Limit	Remark
	MHz	dBuV/m	Level	Factor	Limit	Line	
			dBuV	dB/m	dB	dBuV/m	
1	77.10	29.87	49.07	-19.20	-10.13	40.00	QP
2	152.88	35.94	50.51	-14.57	-7.56	43.50	QP
3	229.32	35.28	51.38	-16.10	-10.72	46.00	QP
4 !	306.14	41.03	54.63	-13.60	-4.97	46.00	QP
5	383.79	35.61	47.29	-11.68	-10.39	46.00	QP
6	537.81	37.10	45.30	-8.20	-8.90	46.00	QP



**7.6 Test Result and Data (Above 1GHz)**

Power	: DC 3.7V	Pol/Phase	: VERTICAL
Test Mode 1	: GFSK, CH0	Temperature	: 28 °C
Memo	: X axis	Humidity	: 65 %

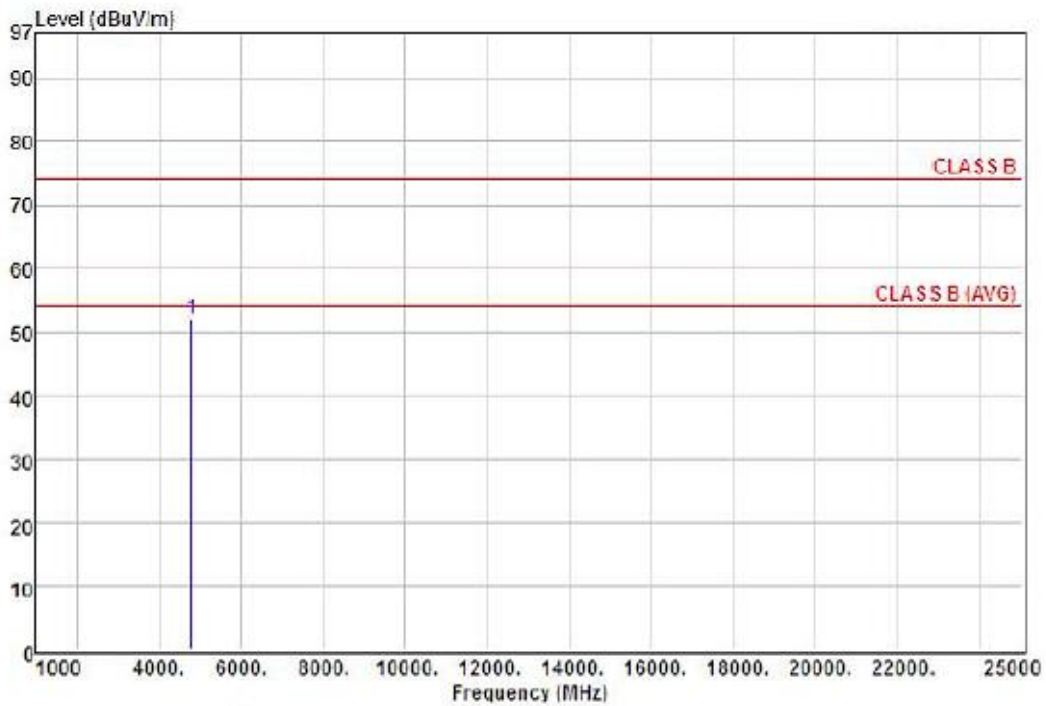

```

Site          : Radiation
Condition    : CLASS B 3m AH-118(1-180)104 VERTICAL
EUT          :
Power        : DC 3.7V
Mode         : Transmit
Temperature  : 23
Humidity     : 65
Memo         : GFSK CH0
  
```

```

Remarks:    : 1. Result=Read Value+Factor
              : 2. Factor=Antenna Factor+Cable loss-
              : Amplifier Factor
  
```

	Freq	Level	Read	Over	Limit	
	MHz	dBuV/m	Level	Limit	Line	Remark
			Factor			
			dB/m	dB	dBuV/m	
1	4804.00	52.05	59.55	-7.50	-21.95	74.00 Peak



Power	: DC 3.7V	Pol/Phase	: HORIZONTAL
Test Mode 1	: GFSK, CH0	Temperature	: 28 °C
Memo	: X axis	Humidity	: 65 %

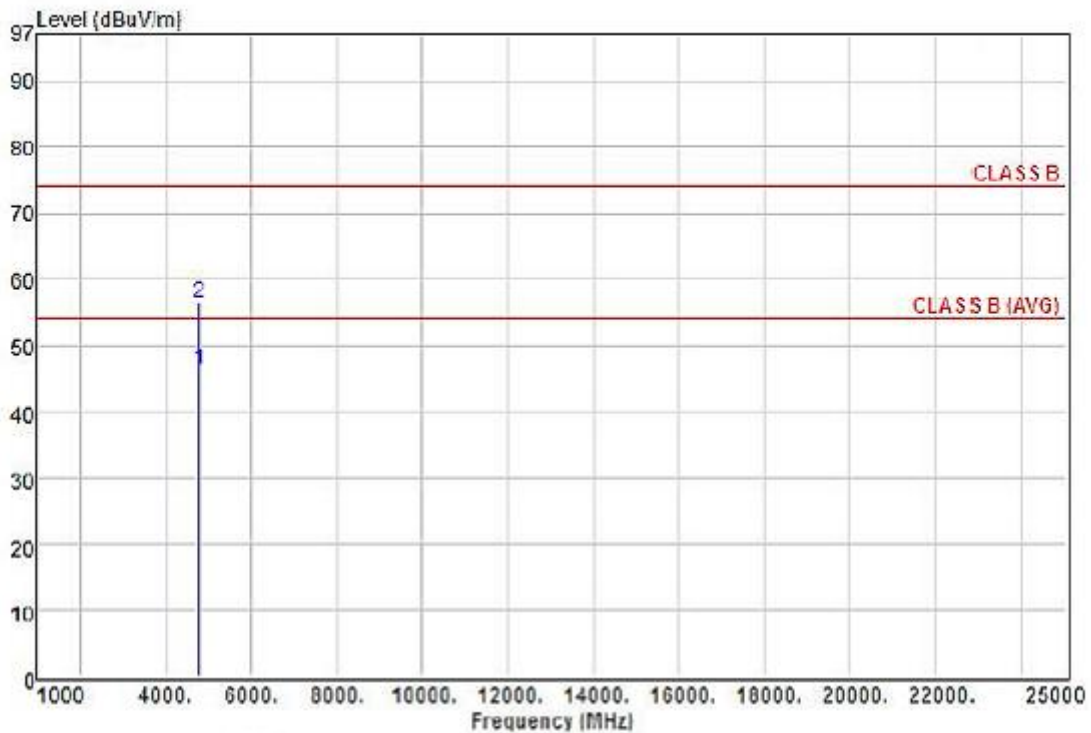

```

Site           : Radiation
Condition      : CLASS B 3m AH-118(1-180)104 HDRIZONTAL
EUT           : 14090402
Power         : DC 3.7V
Mode          : Transmit
Temperature   : 23
Humidity      : 65
Memo          : GFSK CH0
  
```

```

Remarks:
: 1. Result=Read Value+Factor
: 2. Factor=Antenna Factor+Cable loss-
: Amplifier Factor
  
```

	Freq	Level	Read Level	Over Factor	Limit	Limit Line	Remark
	MHz	dBuV/m	dBuV	dB/m	dB	dBuV/m	
1	4804.00	46.25	53.75	-7.50	-7.75	54.00	Average
2	4804.00	56.32	63.82	-7.50	-17.68	74.00	Peak





Power	: DC 3.7V	Pol/Phase	: VERTICAL
Test Mode 1	: GFSK, CH19	Temperature	: 28 °C
Memo	: X axis	Humidity	: 65 %

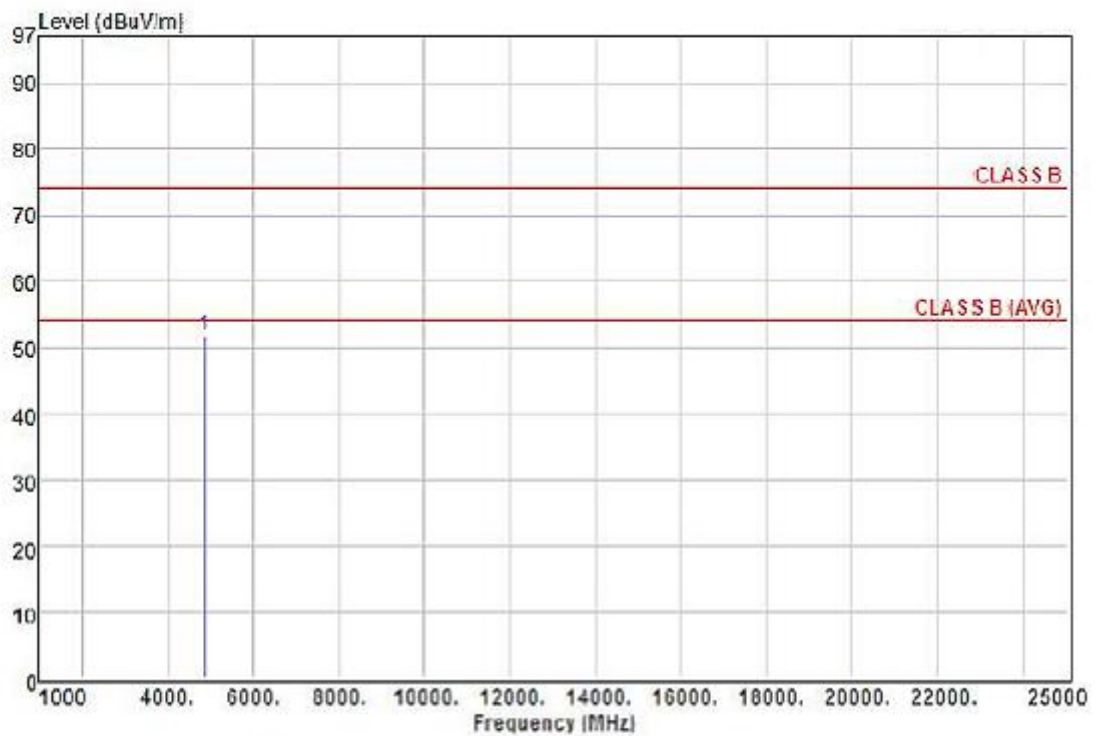

```

Site           : Radiation
Condition      : CLASS B 3m AH-118(1-180)104 VERTICAL
EUT           :
Power          : DC 3.7V
Mode          : Transmit
Temperature    : 23
Humidity       : 65
Memo          : GFSK CH19
  
```

```

Remarks:      : 1. Result=Read Value+Factor
                : 2. Factor=Antenna Factor+Cable loss-
                : Amplifier Factor
  
```

	Freq	Level	Read	Over	Limit		
	MHz	dBuV/m	Level	Factor	Limit	Line	
			dBuV	dB/m	dB	dBuV/m	
1	4880.00	51.83	58.97	-7.14	-22.17	74.00	Peak



Power	: DC 3.7V	Pol/Phase	: HORIZONTAL
Test Mode 1	: GFSK, CH19	Temperature	: 28 °C
Memo	: X axis	Humidity	: 65 %

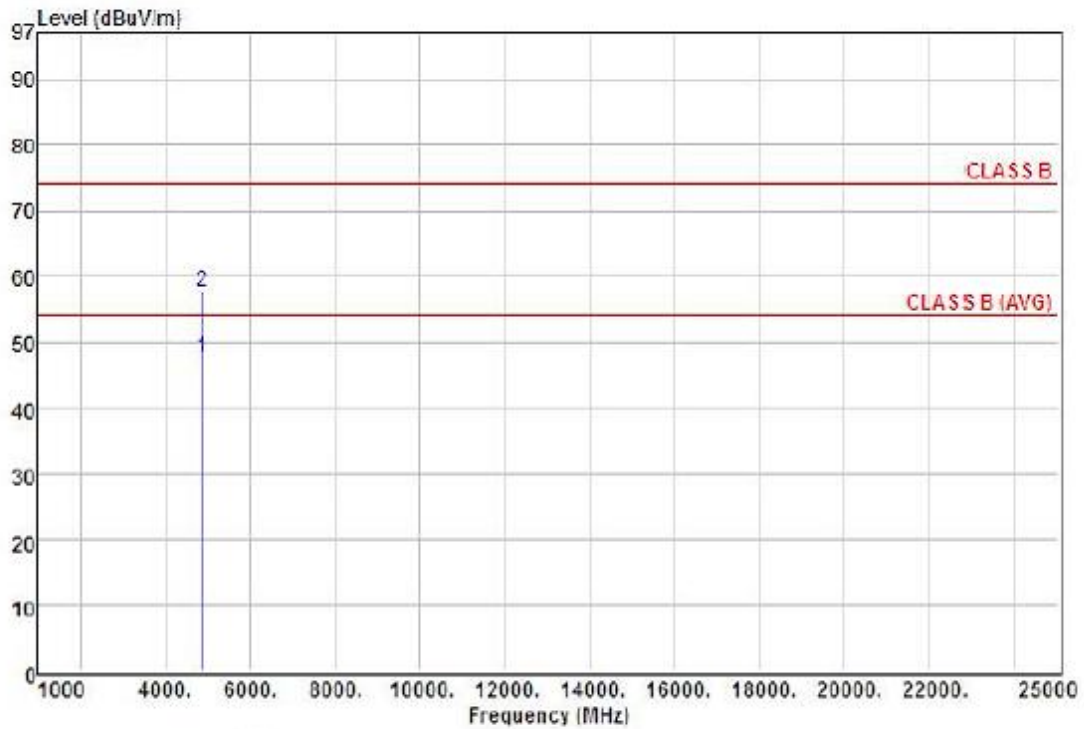

```

Site      : Radiation
Condition : CLASS B 3m AH-118(1-180)104 HORIZONTAL
EUT      :
Power    : DC 3.7V
Mode     : Transmit
Temperature : 23
Humidity : 65
Memo     : GFSK CH19
  
```

```

Remarks:
: 1. Result=Read Value+Factor
: 2. Factor=Antenna Factor+Cable loss-
: Amplifier Factor
  
```

	Freq	Level	Read Level	Factor	Over Limit	Limit Line	Remark
	MHz	dBuV/m	dBuV	dB/m	dB	dBuV/m	
1	4879.90	47.50	54.64	-7.14	-6.50	54.00	Average
2	4879.90	57.68	64.82	-7.14	-16.32	74.00	Peak



Power	: DC 3.7V	Pol/Phase	: VERTICAL
Test Mode 1	: GFSK, CH39	Temperature	: 28 °C
Memo	: X axis	Humidity	: 65 %

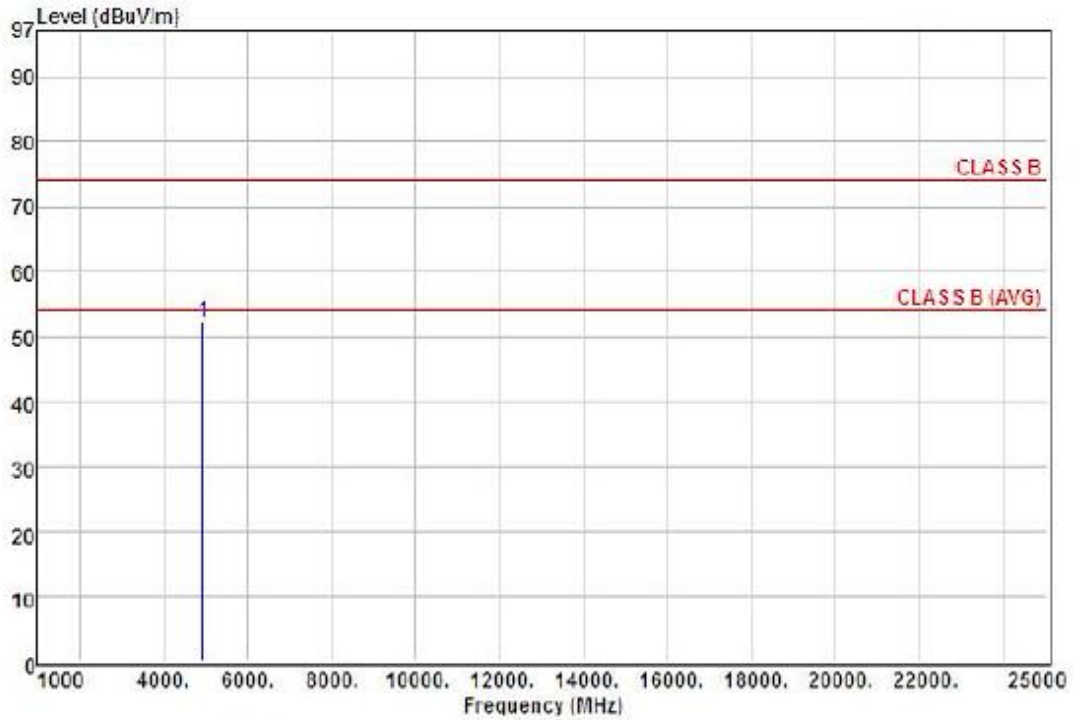

```

Site      : Radiation
Condition : CLASS B 3m AH-118(1-130)104 VERTICAL
EUT      :
Power     : DC 3.7V
Mode      : Transmit
Temperature : 23
Humidity  : 65
Memo      : GFSK CH39
  
```

```

Remarks:
: 1. Result=Read Value+Factor
: 2. Factor=Antenna Factor+Cable loss-
: Amplifier Factor
  
```

	Freq	Level	Read Level	Factor	Over Limit	Limit Line	Remark
	MHz	dBuV/m	dBuV	dB/m	dB	dBuV/m	
1	4960.10	52.23	58.97	-6.74	-21.77	74.00	Peak



Power	: DC 3.7V	Pol/Phase	: HORIZONTAL
Test Mode 1	: GFSK, CH39	Temperature	: 28 °C
Memo	: X axis	Humidity	: 65 %

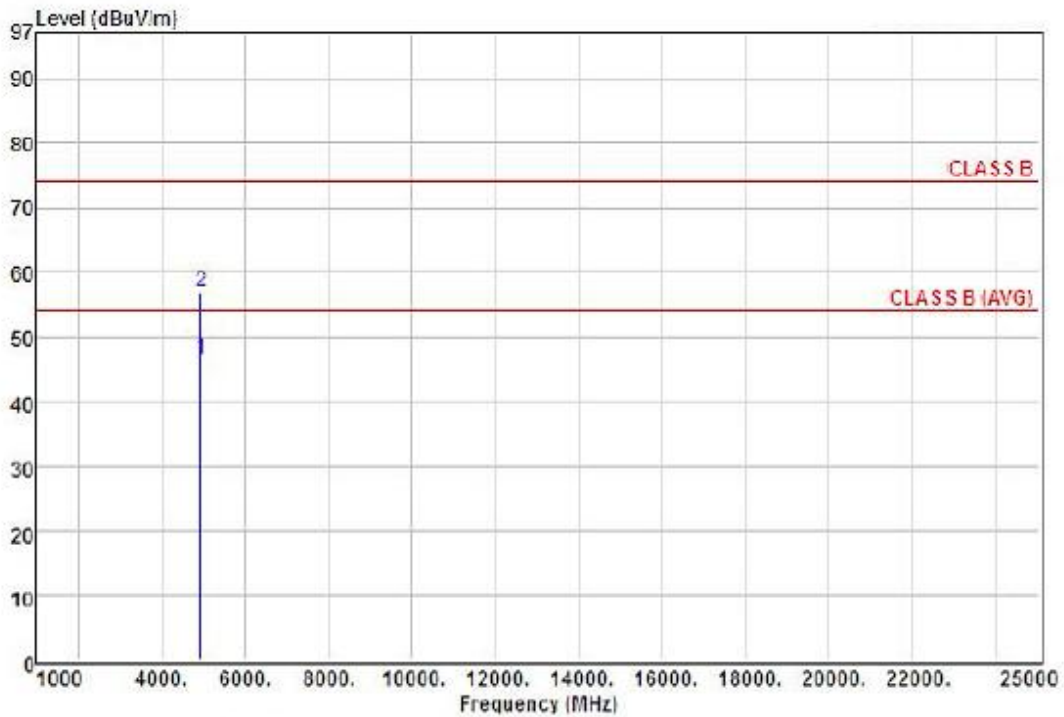

```

Site      : Radiation
Condition : CLASS B 3m AH-118(1-180)104 HORIZONTAL
EUT       :
Power     : DC 3.7V
Mode      : Transmit
Temperature : 23
Humidity  : 65
Memo      : GFSK CH39
  
```

```

Remarks: : 1. Result=Read Value+Factor
           : 2. Factor=Antenna Factor+Cable loss-
           : Amplifier Factor
  
```

	Freq	Level	Read Level	Over Factor	Limit	Limit Line	Remark
	MHz	dBuV/m	dBuV	dB/m	dB	dBuV/m	
1	4960.10	46.58	53.32	-6.74	-7.42	54.00	Average
2	4960.10	56.90	63.64	-6.74	-17.10	74.00	Peak



## 8. 6dB Bandwidth Measurement Data

### 8.1 Test Limit

The minimum of 6dB Bandwidth Measurement is 0.5 MHz.

### 8.2 Test Procedures

- a. The transmitter output was connected to the spectrum analyzer.
- b. Set RBW of spectrum analyzer to 1~5% of the emission bandwidth and  $VBW \geq 3x RBW$ .
- c. The 6 dB bandwidth is defined as the total spectrum the power of which is higher than peak power minus 6 dB.
- d. The 6dB Bandwidth was measured and recorded.

### 8.3 Test Setup Layout

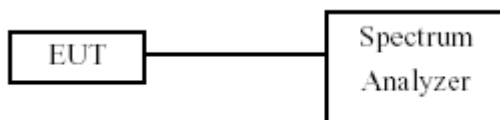



### 8.4 Test Result and Data

Test Date: Jun. 12, 2015

Temperature: 25°C

Atmospheric pressure: 1025 hPa

Humidity: 60%

Modulation Standard	Channel	Frequency (MHz)	6dB Bandwidth (MHz)
GFSK (1Mbps)	0	2402	0.65
	19	2440	0.64
	39	2480	0.64

Modulation Standard: GFSK (1Mbps)  
Channel: 0

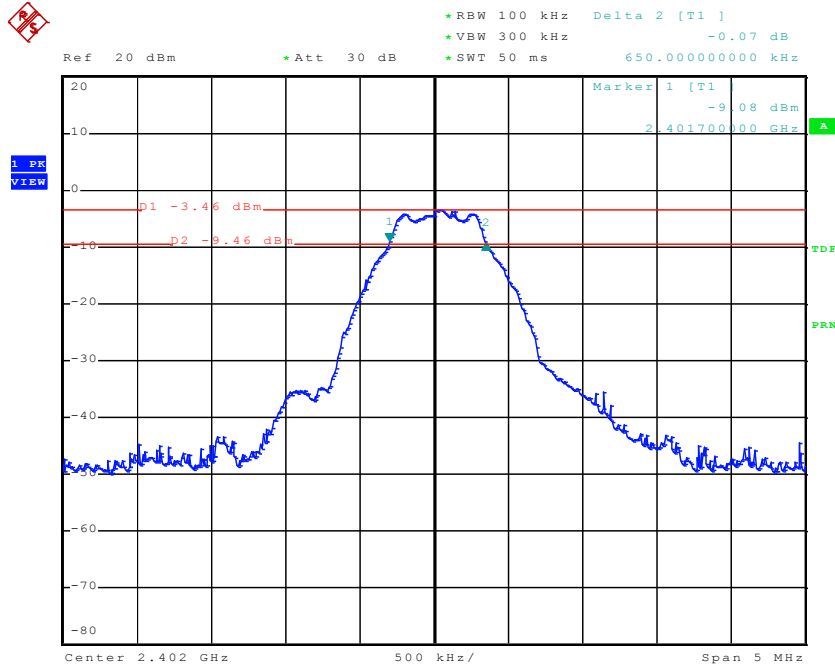



Modulation Standard: GFSK (1Mbps)  
Channel: 19

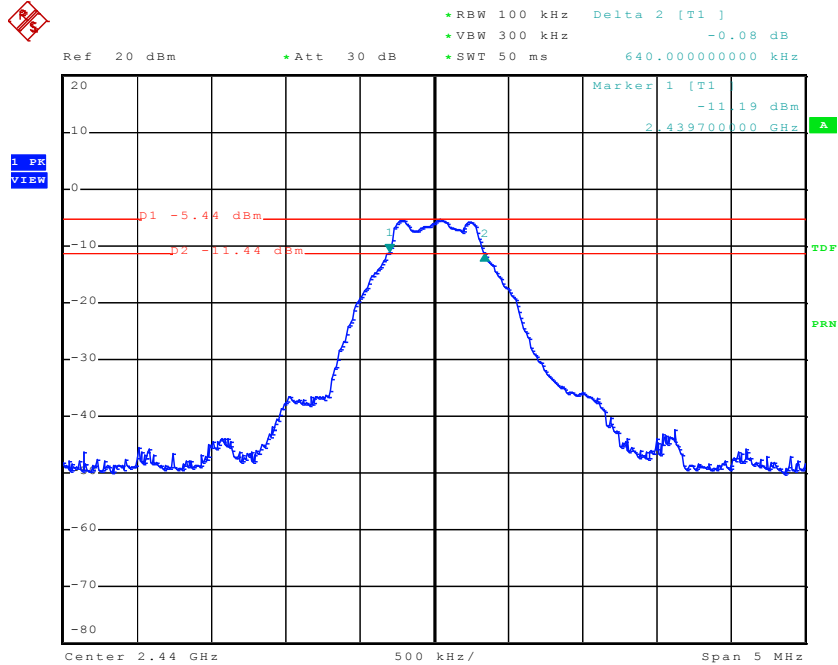

Modulation Standard: GFSK (1Mbps)  
Channel: 39

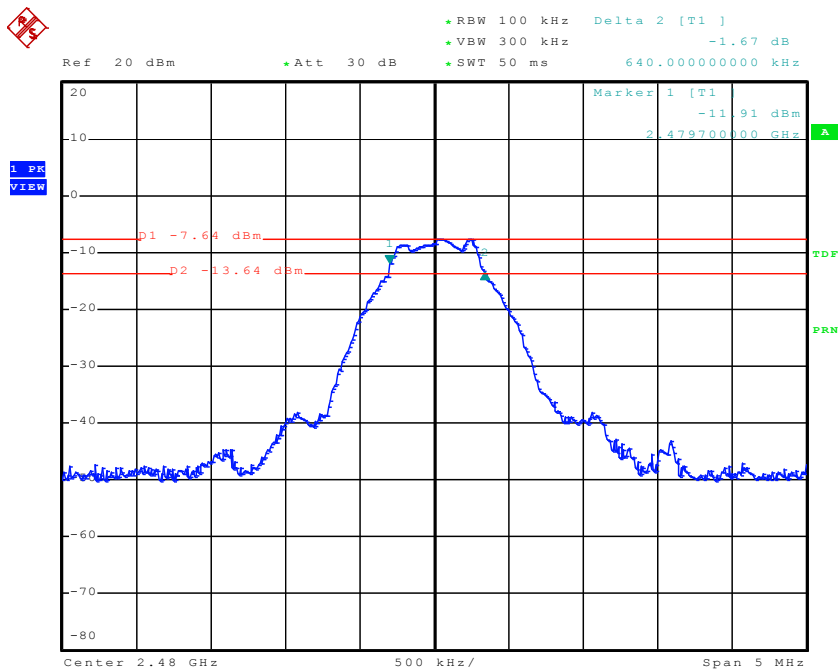



## **9. Maximum Peak and Average Output Power**

### **9.1 Test Limit**

The Maximum Peak Output Power Measurement is 30dBm.

### **9.2 Test Procedures**

- a. Peak power is measured using the wideband power meter.
- b. Power is integrated over a bandwidth greater than or equal to the 99% bandwidth.
- c. The Peak and Average Output Power was measured and recorded.

### **9.3 Test Setup Layout**

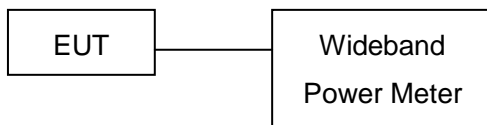





### 9.4 Test Result and Data

Test Date: Jun. 12, 2015

Temperature: 25°C

Atmospheric pressure: 1025 hPa

Humidity: 60%

Modulation Standard	Channel	Frequency (MHz)	Peak Power Output (dBm)	Peak Power Output (mW)
GFSK (1Mbps)	0	2402	-1.37	0.7
	19	2440	-3.42	0.5
	39	2480	-5.61	0.3

Modulation Standard	Channel	Frequency (MHz)	Average Power Output (dBm)	Average Power Output (mW)
GFSK (1Mbps)	0	2402	-1.73	0.7
	19	2440	-3.72	0.4
	39	2480	-5.98	0.3



## 10. Power Spectral Density

### 10.1 Test Limit

The Maximum of Power Spectral Density Measurement is 8dBm

### 10.2 Test Procedures

- a. The transmitter output was connected to spectrum analyzer.
- b. The spectrum analyzer's resolution bandwidth were set at 3KHz RBW and 30KHz VBW as that of the fundamental frequency. Set the sweep time=auto couple.
- c. The power spectral density was measured and recorded.

### 10.3 Test Setup Layout

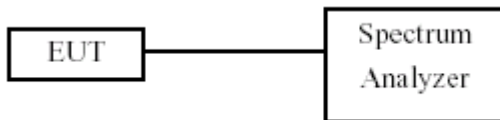



### 10.4 Test Result and Data

Test Date: Jun. 12, 2015

Temperature: 25°C

Atmospheric pressure: 1025 hPa

Humidity: 60%

Modulation Standard	Channel	Frequency (MHz)	Measured Power Density (dBm)
GFSK (1Mbps)	0	2402	-14.98
	19	2440	-17.55
	39	2480	-17.73

Modulation Standard: GFSK (1Mbps)

Channel: 0

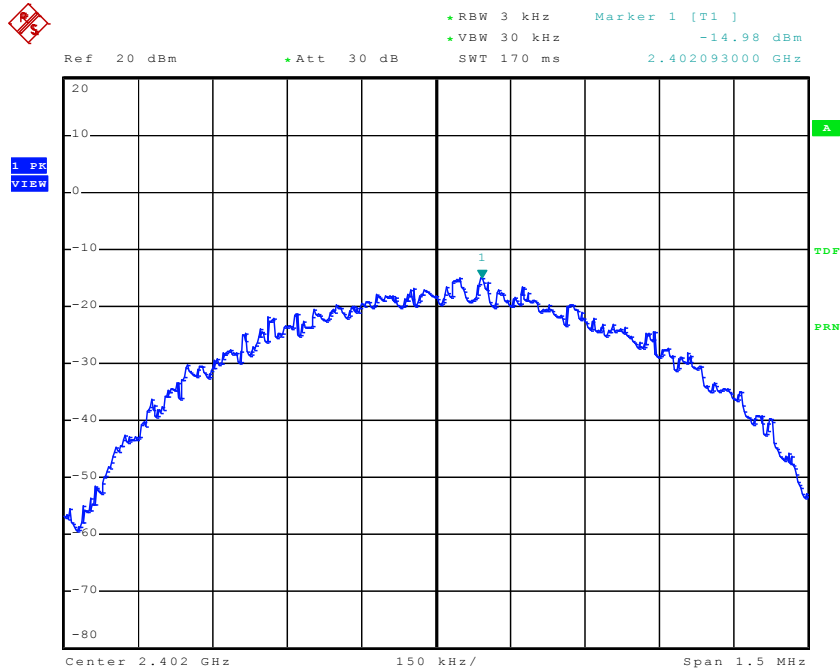



Modulation Standard: GFSK (1Mbps)  
Channel: 19

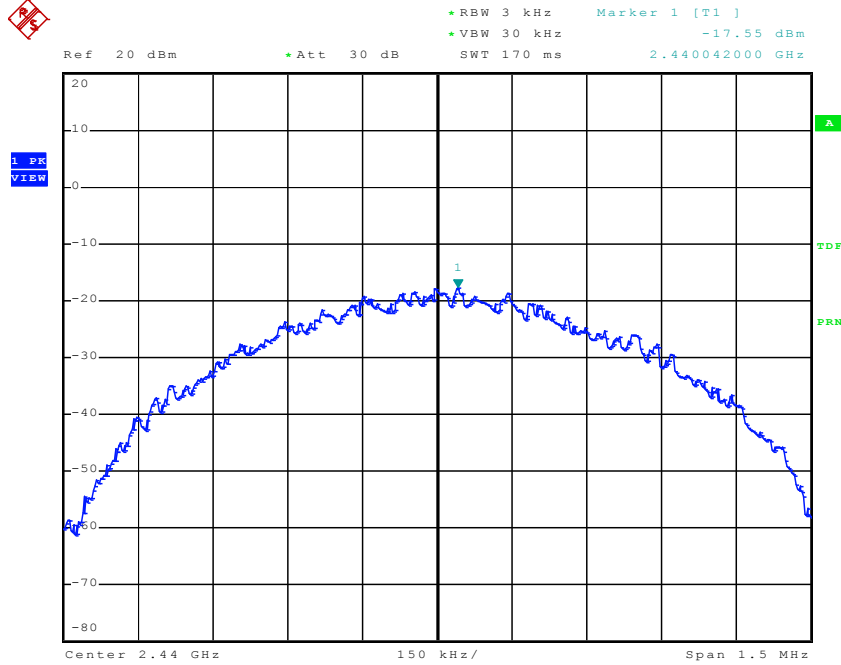

Modulation Standard: GFSK (1Mbps)  
Channel: 39

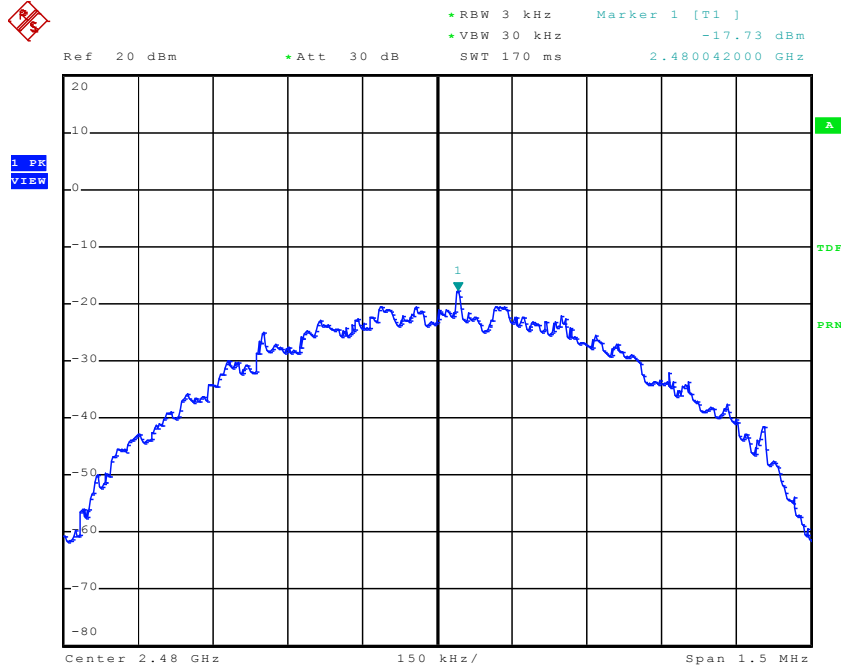



## 11. Band Edges Measurement

### 11.1 Test Limit

Below  $-20\text{dB}$  of the highest emission level of operating band (In 100 kHz Resolution Bandwidth)

### 11.2 Test Procedure

- a. The transmitter output was connected to the spectrum analyzer via a low lose cable.
- b. Set RBW of spectrum analyzer to 100 KHz and VBW of spectrum analyzer to 300 KHz with convenient frequency span including 100 KHz bandwidth from band edge.
- c. Peak conducted output power measured within any 100 kHz outside the authorized frequency band shall be attenuated by at least 20dB relative to the maximum measured in-band peak PSD level.
- d. The band edges was measured and recorded.

### 11.3 Test Setup Layout

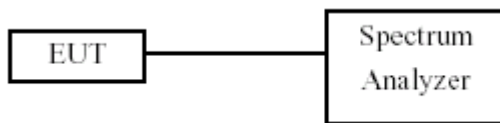



### 11.4 Test Result and Data

Test Date: Jun. 12, 2015

Temperature: 25°C

Atmospheric pressure: 1025 hPa

Humidity: 60%

Modulation Standard	Channel	Frequency (MHz)	maximum value in frequency (MHz)	maximum value (dBm)
GFSK (1Mbps)	0	2402	2394.00	-41.72
	39	2480	2484.30	-43.52



Modulation Standard: GFSK (1Mbps)  
Channel: 0

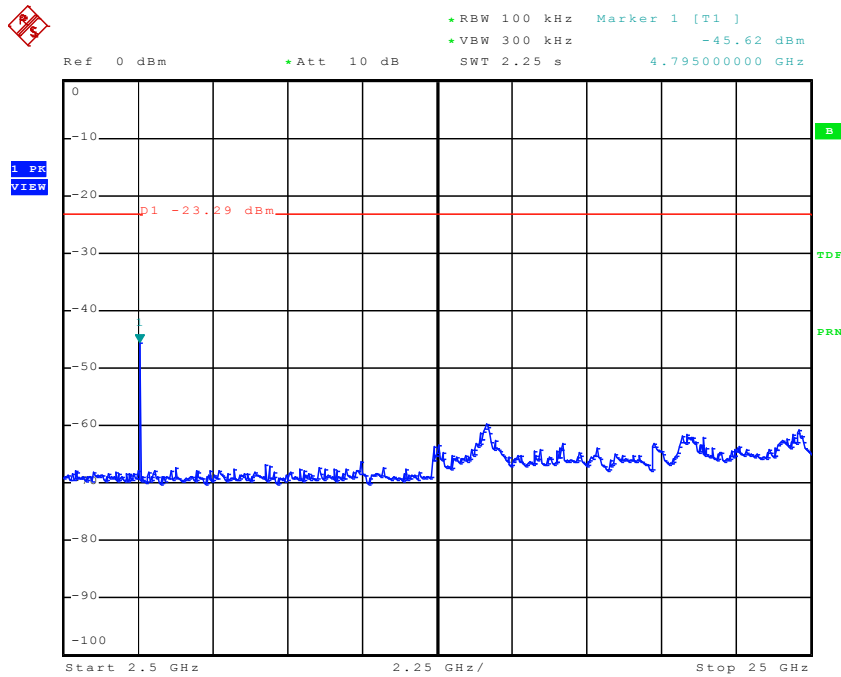
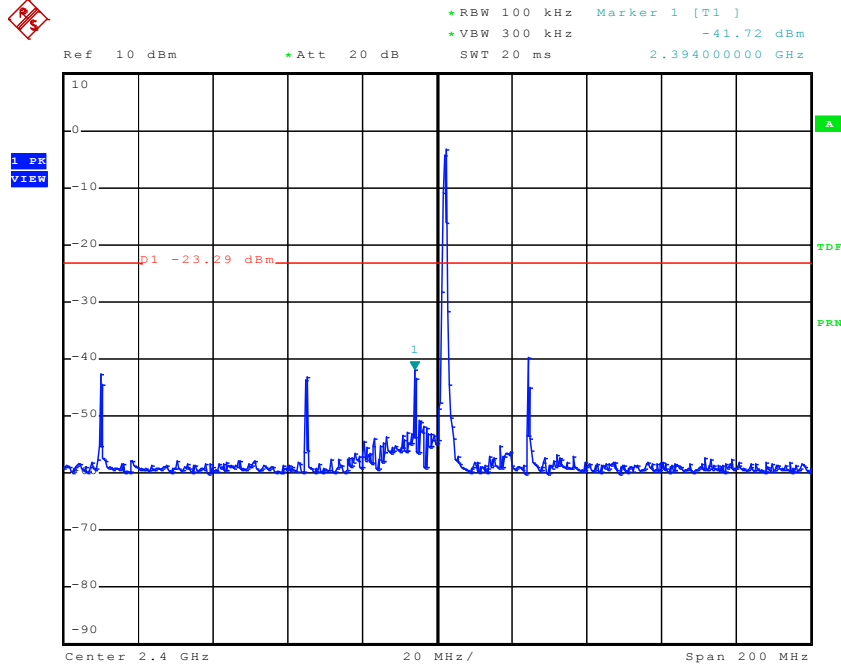



Modulation Standard: GFSK (1Mbps)  
Channel: 39

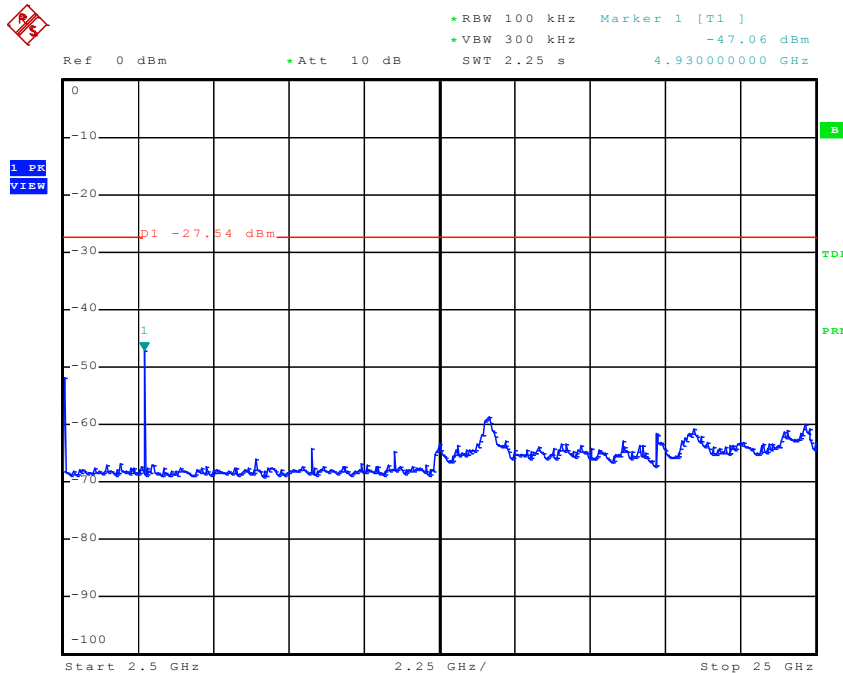
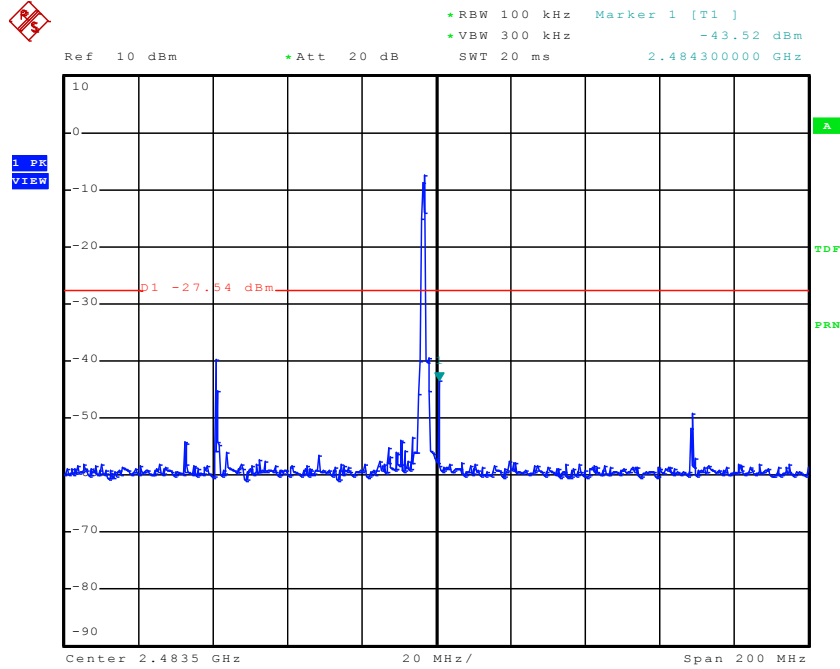





### 11.5 Restrict Band Emission Measurement Data

Power	: DC 3.7V	Pol/Phase	: VERTICAL
Test Mode 1	: GFSK	Temperature	: 25 °C
Test Date	: Jun. 12, 2015	Humidity	: 60 %
Memo	: X axis		

Channel 0						Fundamental Frequency: 2402 MHz				
Frequency (MHz)	Ant-Pol H/V	Meter Reading (dBuV)	Corrected Factor (dB)	Result (dBuV/m)	Remark	Limit (dBuV/m)		Margin (dB)	Table Deg.	Ant High (m)
						Peak	Ave			
2389.47	H	68.42	-15.26	53.16	Peak	74	54	-20.84	161	1.00
---	H	---	---	---	Ave	74	54	---	---	---
2376.43	V	62.30	-15.29	47.01	Peak	74	54	-26.99	192	1.00
---	V	---	---	---	Ave	74	54	---	---	---
Channel 39						Fundamental Frequency: 2480 MHz				
Frequency (MHz)	Ant-Pol H/V	Meter Reading (dBuV)	Corrected Factor (dB)	Result (dBuV/m)	Remark	Limit (dBuV/m)		Margin (dB)	Table Deg.	Ant High (m)
						Peak	Ave			
2483.54	H	67.89	-14.98	42.91	Peak	74	54	-21.09	164	1.00
---	H	---	---	---	Ave	74	54	---	---	---
2483.81	V	57.35	-14.98	42.37	Peak	74	54	-21.63	190	1.00
---	V	---	---	---	Ave	74	54	---	---	---

Note:

1. Emission level = Reading level + Correction factor
2. Correction factor : Antenna factor, Cable loss, Pre-Amp, etc.
3. All emissions as described above were determining by rotating the EUT through three orthogonal axes to maximizing the emissions if the EUT belongs to hand-held or body-worn devices.
4. Measurements above 1000 MHz, Peak detector setting:  
1 MHz RBW with 1 MHz VBW (Peak Detector).
5. Measurements above 1000 MHz, Average detector setting:  
1 MHz RBW with 1 MHz VBW (RMS Detector).
6. Peak detector measurement data will represent the worst case results.



7. Where limits are specified for both average and peak detector functions, if the peak measured value complies with the average limit, it is unnecessary to perform an average measurement.



## 12. Restricted Bands of Operation

Only spurious emissions are permitted in any of the frequency bands listed below:

MHz	MHz	MHz	GHz
0.09000 – 0.11000	16.42000 – 16.42300	399.9 – 410.0	4.500 – 5.150
0.49500 – 0.505**	16.69475 – 16.69525	608.0 – 614.0	5.350 – 5.460
2.17350 – 2.19050	16.80425 – 16.80475	960.0 – 1240.0	7.250 – 7.750
4.12500 – 4.12800	25.50000 – 25.67000	1300.0 – 1427.0	8.025 – 8.500
4.17725 – 4.17775	37.50000 – 38.25000	1435.0 – 1626.5	9.000 – 9.200
4.20725 – 4.20775	73.00000 – 74.60000	1645.5 – 1646.5	9.300 – 9.500
6.21500 – 6.21800	74.80000 – 75.20000	1660.0 – 1710.0	10.600 – 12.700
6.26775 – 6.26825	108.00000 – 121.94000	1718.8 – 1722.2	13.250 – 13.400
6.31175 – 6.31225	123.00000 – 138.00000	2200.0 – 2300.0	14.470 – 14.500
8.29100 – 8.29400	149.90000 – 150.05000	2310.0 – 2390.0	15.350 – 16.200
8.36200 – 8.36600	156.52475 – 156.52525	2483.5 – 2500.0	17.700 – 21.400
8.37625 – 8.38675	156.70000 – 156.90000	2655.0 – 2900.0	22.010 – 23.120
8.41425 – 8.41475	162.01250 – 167.17000	3260.0 – 3267.0	23.600 – 24.000
12.29000 – 12.29300	167.72000 – 173.20000	3332.0 – 3339.0	31.200 – 31.800
12.51975 – 12.52025	240.00000 – 285.00000	3345.8 – 3358.0	36.430 – 36.500
12.57675 – 12.57725	322.00000 – 335.40000	3600.0 – 4400.0	Above 38.6
13.36000 – 13.41000			

\*\* : Until February 1, 1999, this restricted band shall be 0.490-0.510 MHz

### 12.1 Labeling Requirement

The device shall bear the following statement in a conspicuous location on the device:

This device complies with part 15 of the FCC Rules. Operation is subject to the following two conditions: (1) This device may not cause harmful interference, and (2) this device must accept any interference received, including interference that may cause undesired operation.