

TEST REPORT

Report No.: 24090042HKG-001

HANK ELECTRONICS VIETNAM LTD

Application For Certification
(Original Grant)

FCC ID: 2A9G4HKWP21071-15L

Snapstand Qi2 Wireless Charger

Prepared and Checked by:

Approved by:

Leung Chun Ning, Peter
Assistant Engineer
Date: October 29, 2024

Wong Cheuk Ho, Herbert
Assistant Manager
Date: October 29, 2024

Intertek's standard Terms and Conditions can be obtained at our website <http://www.intertek.com/terms/>.

The test report only allows to be revised within the retention period unless further standard or the requirement was noticed.

This report is for the exclusive use of Intertek's Client and is provided pursuant to the agreement between Intertek and its Client. Intertek's responsibility and liability are limited to the terms and conditions of the agreement. Intertek assumes no liability to any party, other than to the Client in accordance with the agreement, for any loss, expense or damage occasioned by the use of this report. Only the Client is authorized to permit copying or distribution of this report and then only in its entirety. Any use of the Intertek name or one of its marks for the sale or advertisement of the tested material, product or service must first be approved in writing by Intertek. The observations and test results in this report are relevant only to the sample tested. This report by itself does not imply that the material, product, or service is or has ever been under an Intertek certification program.

© 2017 Intertek

TEST REPORT

GENERAL INFORMATION

Grantee:	HANK ELECTRONICS VIETNAM LTD
Grantee Address:	No. 7, 11 Street VSIP Tu Son, 16353 Bac Ninh Province, Vietnam.
Manufacturer:	Hank (Electronics) Co., Ltd.
Manufacturer Address:	No. 118, Shaxin Road, Tangxia Town, Dongguan City, Guangdong Province, China.
Brand Name:	Native Union
Model:	HKWP21071-15L
Type of EUT:	Wireless Power Transfer Device - Transmitter
Description of EUT:	Snapstand Qi2 Wireless Charger
Serial Number:	37023824
FCC ID:	2A9G4HKWP21071-15L
Date of Sample Submitted:	September 02, 2024
Date of Test:	September 02, 2024 to September 12, 2024
Report No.:	24090042HKG-001
Report Date:	October 29, 2024
Environmental Conditions:	Temperature: +10 to 40°C Humidity: 10 to 90%
Conclusion:	Test was conducted by client submitted sample. The submitted sample as received complied with the 47 CFR Part 15 Certification.

TEST REPORT

SUMMARY OF TEST RESULT

Test Specification	Reference	Results
Transmitter Power Line Conducted Emissions	15.207	Complied
Radiated Emission	15.249, 15.209	Complied
Radiated Emission on the Bandedge		
Radiated Emission in Restricted Bands	15.205	Complied

The equipment under test is found to be complying with the following standards:
FCC Part 15, October 1, 2022 Edition

- Note:
1. The EUT uses a permanently attached antenna which, in accordance to section 15.203, is considered sufficient to comply with the pervisions of this section.
 2. Pursuant to FCC part 15 Section 15.215(c), the 20 dB bandwidth of the emission was contained within the frequency band designated (mentioned as above) which the EUT operated. The effects, if any, from frequency sweeping, frequency hopping, other modulation techniques and frequency stability over excepted variations in temperature and supply voltage were considered.

TEST REPORT

TABLE OF CONTENTS

1.0 GENERAL DESCRIPTION..... 5

1.1 Product Description5

1.2 Related Submittal(s) Grants.....5

1.3 Test Methodology5

1.4 Test Facility.....5

2.0 SYSTEM TEST CONFIGURATION..... 6

2.1 Justification6

2.2 EUT Exercising Software.....6

2.3 Special Accessories.....6

2.4 Measurement Uncertainty.....6

2.5 Support Equipment List and Description7

3.0 EMISSION RESULTS 8

3.1 Field Strength Calculation8

3.2 Radiated Emission Configuration Photograph.....9

3.3 Radiated Emission Data9

3.4 Conducted Emission Configuration Photograph9

3.5 Conducted Emission Data9

4.0 EQUIPMENT PHOTOGRAPHS..... 18

5.0 PRODUCT LABELLING 18

6.0 TECHNICAL SPECIFICATIONS 18

7.0 INSTRUCTION MANUAL 18

8.0 MISCELLANEOUS INFORMATION 19

8.1 Measured Bandwidth.....19

8.2 Emissions Test Procedures.....19

8.3 Occupied Bandwidth.....22

9.0 CONFIDENTIALITY REQUEST..... 24

10.0 EQUIPMENT LIST 24

TEST REPORT

1.0 GENERAL DESCRIPTION

1.1 Product Description

The Equipment Under Test (EUT), is a wireless charger that is designed to work on table. The EUT is powered by 120VAC, the charge pad is operated at frequency range of 127kHz to 360kHz. The maximum wireless power transmission for the charge pad is 15W.

Antenna Type: Internal, Integral

For electronic filing, the brief circuit description is saved with filename: descri.pdf.

1.2 Related Submittal(s) Grants

This is a single application for certification of a transmitter.

The receiver for this transmitter is exempted from the Part 15 technical rules per 15.101(b).

1.3 Test Methodology

Both AC mains line-conducted and radiated emission measurements were performed according to the procedures in ANSI C63.10 (2013). All radiated measurements were performed in an 3m Chamber. Preliminary scans were performed in the 3m Chamber only to determine worst case modes. All radiated tests were performed at an antenna to EUT distance of 3 meters, unless stated otherwise in the “**Justification Section**” of this Application.

1.4 Test Facility

The 3m Chamber and conducted measurement facility used to collect the radiated data is located at Workshop No. 3, G/F., World-Wide Industrial Centre, 43-47 Shan Mei Street, Fo Tan, Sha Tin, N.T., Hong Kong SAR, China. This test facility and site measurement data have been placed on file with the FCC.

TEST REPORT

2.0 SYSTEM TEST CONFIGURATION

2.1 Justification

The system was configured for testing in a typical fashion (as a customer would normally use it), and in the confines as outlined in ANSI C63.10 (2013).

The device was powered by 120VAC.

For maximizing emissions below 30 MHz, the EUT was rotated through 360°, the centre of the loop antenna was placed 1 meter above the ground, and the antenna polarization was changed. For maximizing emission at and above 30 MHz, the EUT was rotated through 360°, the antenna height was varied from 1 meter to 4 meters above the ground plane, and the antenna polarization was changed. This step by step procedure for maximizing emissions led to the data report in Exhibit 3.0.

The rear of unit shall be flushed with the rear of the table.

The equipment under test (EUT) was configured for testing in a typical fashion (as a customer would normally use it). The EUT was mounted to a plastic stand if necessary and placed on the wooden turntable, which enabled the engineer to maximize emissions through its placement in the three orthogonal axes.

There are different testing conditions for this EUT, standby mode, charging with the smartphone charge pad only, charging with the smartwatch charge pad only and charging with full load. Only the worst-case data is shown in this report.

2.2 EUT Exercising Software

There was no special software to exercise the device. Once the unit is powered up, it transmits the RF Signal continuously.

2.3 Special Accessories

There are no special accessories necessary for compliance of this product.

2.4 Measurement Uncertainty

Decision Rule for compliance: For FCC/IC standard, the measured value must be within the limits of applicable standard without accounting for the measurement uncertainty. For EN/IEC/HKTA/HKTC standard, conformity rules will be used as per standard directly excepted EN/IEC 61000-3-2, EN/IEC 61000-3-3, HKTA1004, HKCA1008, HKTA1019, HKTA1020, HKTA1041 and HKTA1044.

Uncertainty and Compliance - Unless the standard specifically states that measured values are to be extended by the measurement uncertainty in determining compliance, all compliance determinations are based on the actual measured value.

TEST REPORT

2.5 Support Equipment List and Description

Description	Remark
An AC adaptor (Model: RH-PD35W; Input: 100-240VAC 50/60Hz 0.8A(MAX); Output: 5.0V 3.0A, 9.0V 3.0A, 12.0V 2.8A, 15.0V 2.33A, 20.0V 1.75A)	Provided by Intertek
iPhone	Provided by Intertek
15W Loading	Provided by Intertek

TEST REPORT

3.0 EMISSION RESULTS

Data is included of the worst case configuration (the configuration which resulted in the highest emission levels). A sample calculation, configuration photographs and data tables of the emissions are included.

3.1 Field Strength Calculation

The field strength is calculated by adding the Antenna Factor and Cable Factor, and subtracting the Amplifier Gain (if any), Average Factor (optional) from the measured reading.

The basic equation with a sample calculation is as follows:

$$FS = RA + AF + CF - AG - AV$$

where

- FS = Field Strength in dB μ V/m
- RA = Receiver Amplitude (including preamplifier) in dB μ V
- AF = Antenna Factor in dB
- CF = Cable Attenuation Factor in dB
- AG = Amplifier Gain in dB
- AV = Average Factor in dB

In the following table(s), the reading shown on the data table reflects the preamplifier gain.

An example for the calculations in the following table is as follows:

$$FS = RR + LF$$

where

- FS = Field Strength in dB μ V/m
- RR = RA - AG - AV in dB μ V
- LF = CF + AF in dB

Assume a receiver reading of 52.0 dB μ V is obtained. The antenna factor of 7.4 dB and cable factor of 1.6 dB are added. The amplifier gain of 29.0 dB and average factor of 5.0 dB are subtracted, giving a field strength of 27.0 dB μ V/m. This value in dB μ V/m was converted to its corresponding level in μ V/m.

RA = 52.0 dB μ V/m	
AF = 7.4 dB	RR = 18.0 dB μ V
CF = 1.6 dB	LF = 9.0 dB
AG = 29.0 dB	
AV = 5.0 dB	
FS = RR + LF	
FS = 18 + 9 = 27 dB μ V/m	

Level in μ V/m = Common Antilogarithm [(27 dB μ V/m)/20] = 22.4 μ V/m

TEST REPORT

3.2 Radiated Emission Configuration Photograph

The worst case in radiated emission was found at 250.917500 MHz

For electronic filing, the worst case radiated emission configuration photographs are saved with filename: setup photos.pdf.

3.3 Radiated Emission Data

The data on the following page lists the significant emission frequencies, the limit and the margin of compliance. Numbers with a minus sign are below the limit.

Judgment: Passed by 14.6 dB

3.4 Conducted Emission Configuration Photograph

The worst case in line-conducted emission was found at 2.175 MHz

For electronic filing, the worst case line-conducted configuration photographs are saved with filename: setup photos.pdf.

3.5 Conducted Emission Data

The plot(s) and data in the following pages list the significant emission frequencies, the limit and the margin of compliance.

Judgment: Pass by 4.8 dB

TEST REPORT

CONDUCTED EMISSION

Model: HKWP21071-15L
Date of Test: September 13, 2024
Worst-Case Operating Mode: Standby Mode

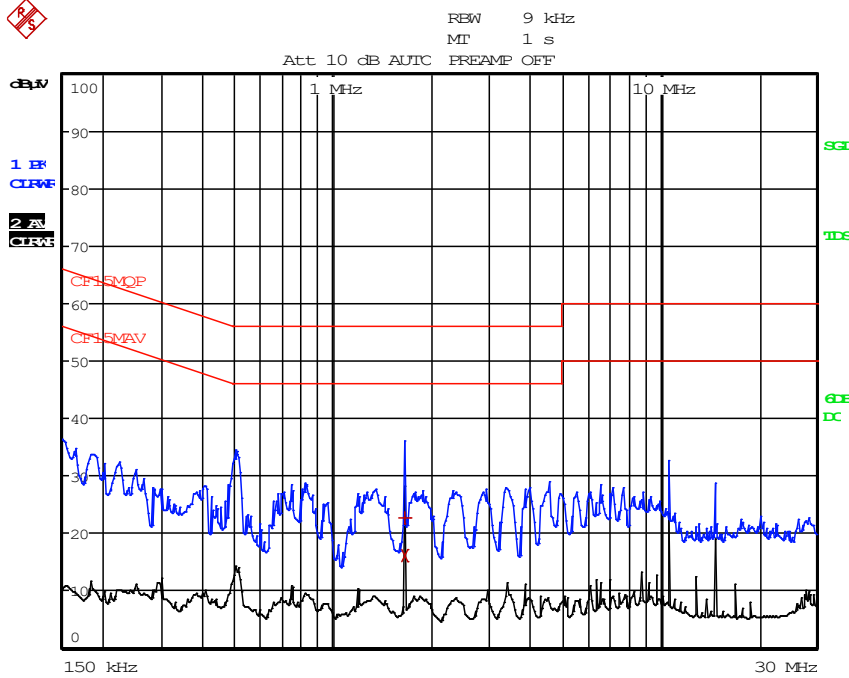

Note: Measurement Uncertainty is ± 4.2 dB at a level of confidence of 95%.

TEST REPORT

CONDUCTED EMISSION (CONT'D)

Model: HKWP21071-15L
Date of Test: September 13, 2024
Worst-Case Operating Mode: Standby Mode

EDIT PEAK LIST (Final Measurement Results)			
TRACE	FREQUENCY	LEVEL dBµV	DELTA LIMIT dB
Trace1:	CF15MQP		
Trace2:	CF15MAV		
Trace3:	---		
1	Quasi Peak 1.662 MHz	22.70 N	-33.29
2	CISPR Average 1.662 MHz	16.01 L1	-29.98

Note: Measurement Uncertainty is ±4.2dB at a level of confidence of 95%.

TEST REPORT

CONDUCTED EMISSION

Model: HKWP21071-15L
Date of Test: September 13, 2024
Worst-Case Operating Mode: Charging with Full Load

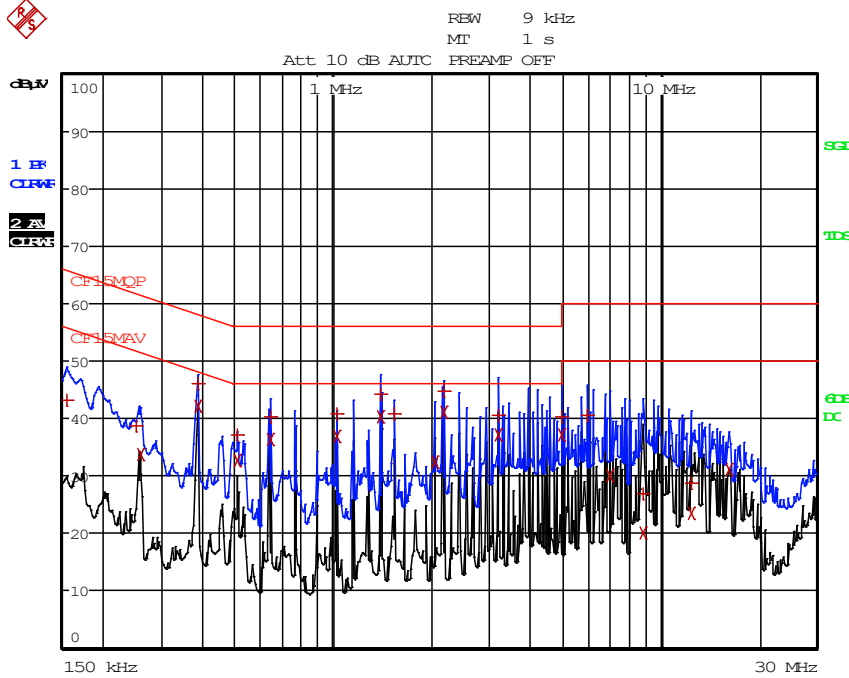

Note: Measurement Uncertainty is ± 4.2 dB at a level of confidence of 95%.

TEST REPORT

CONDUCTED EMISSION (CONT'D)

Model: HKWP21071-15L
Date of Test: September 13, 2024
Worst-Case Operating Mode: Charging with Full Load

EDIT PEAK LIST (Final Measurement Results)				
Trace1:	CF15MQP			
Trace2:	CF15MAV			
Trace3:	---			
TRACE	FREQUENCY	LEVEL dBµV		DELTA LIMIT dB
1 Quasi Peak	154.5 kHz	43.16	N	-22.59
1 Quasi Peak	253.5 kHz	38.77	L1	-22.86
2 CISPR Average	258 kHz	33.66	N	-17.83
1 Quasi Peak	384 kHz	46.08	L1	-12.10
2 CISPR Average	384 kHz	42.17	L1	-6.02
1 Quasi Peak	510 kHz	37.22	L1	-18.77
2 CISPR Average	510 kHz	32.73	N	-13.26
1 Quasi Peak	640.5 kHz	40.34	L1	-15.65
2 CISPR Average	640.5 kHz	36.22	L1	-9.77
1 Quasi Peak	1.023 MHz	40.93	L1	-15.06
2 CISPR Average	1.023 MHz	36.85	N	-9.14
1 Quasi Peak	1.4055 MHz	44.26	L1	-11.73
2 CISPR Average	1.4055 MHz	40.38	N	-5.61
1 Quasi Peak	1.536 MHz	40.77	L1	-15.22
2 CISPR Average	2.0445 MHz	32.39	N	-13.60
1 Quasi Peak	2.175 MHz	44.80	L1	-11.19
2 CISPR Average	2.175 MHz	41.19	N	-4.80
1 Quasi Peak	3.1965 MHz	40.55	L1	-15.44
2 CISPR Average	3.1965 MHz	37.07	N	-8.92
1 Quasi Peak	4.9875 MHz	40.20	L1	-15.79

EDIT PEAK LIST (Final Measurement Results)				
Trace1:	CF15MQP			
Trace2:	CF15MAV			
Trace3:	---			
TRACE	FREQUENCY	LEVEL dBµV		DELTA LIMIT dB
2 CISPR Average	4.9875 MHz	37.25	N	-8.74
1 Quasi Peak	6.009 MHz	40.46	L1	-19.53
2 CISPR Average	7.0305 MHz	29.92	N	-20.07
1 Quasi Peak	8.8215 MHz	26.94	N	-33.05
2 CISPR Average	8.8215 MHz	20.12	N	-29.87
1 Quasi Peak	12.399 MHz	28.71	N	-31.28
2 CISPR Average	12.399 MHz	23.48	N	-26.51
2 CISPR Average	16.233 MHz	31.22	N	-18.77

Note: Measurement Uncertainty is ± 4.2 dB at a level of confidence of 95%.

TEST REPORT

RADIATED EMISSIONS

Model: HKWP21071-15L
Date of Test: September 12, 2024
Worst-Case Operating Mode: Standby Mode

Table 1
Pursuant to FCC Part 15 Section 15.209 Requirement

Frequency (MHz)	Read Level (dBµV)	MaxPeak (dBµV/m)	Quasi-Peak (dBµV/m)	Limit (dBµV/m)	Margin (dB)	Height (cm)	Pol	Azimuth (deg)	Corr. (dB/m)
0.127831	61.48	---	72.88	105.47	-32.59	100.0	O	108.0	11.4
0.232088	44.07	55.47	---	100.29	-44.82	100.0	O	16.0	11.4
0.377606	40.17	51.57	---	96.06	-44.49	100.0	O	92.0	11.4
0.519394	32.47	43.87	---	73.29	-29.43	100.0	O	256.0	11.4
0.892519	30.91	42.41	---	68.59	-26.18	100.0	O	316.0	11.5
1.661156	23.87	35.47	---	63.20	-27.73	100.0	O	23.0	11.6

- NOTES:
1. Peak and Quasi-Peak Detector Data unless otherwise stated.
 2. All measurements were made at 3 meters.
 3. Negative value in the margin column shows emission below limit.
 4. Loop antenna is used for the emissions below 30MHz.
 5. Emissions within the restricted band meets the requirement of FCC Part 15 Section 15.205.
 6. Measurement Uncertainty is ±5.3dB at a level of confidence of 95%.
 7. Corr. (dB/m) = Antenna Factor (dB) + Cable Loss (dB)
 Max Peak (dBµV/m) or Quasi-Peak (dBµV/m) = Corr. (dB/m) + Read Level (dBµV)
 Margin (dB) = Max Peak (dBµV/m) – Limit (dBµV/m) or Quasi-Peak (dBµV/m) – Limit (dBµV/m)

TEST REPORT

RADIATED EMISSIONS

Model: HKWP21071-15L
Date of Test: September 12, 2024
Worst-Case Operating Mode: Charging with Full Load

Table 2
Pursuant to FCC Part 15 Section 15.209 Requirement

Frequency (MHz)	Read Level (dBµV)	MaxPeak (dBµV/m)	Quasi-Peak (dBµV/m)	Limit (dBµV/m)	Margin (dB)	Height (cm)	Pol	Azimuth (deg)	Corr. (dB/m)
0.127831	68.87	---	80.27	105.47	-25.21	100.0	O	80.0	11.4
0.381338	47.76	59.16	---	95.98	-36.82	100.0	O	75.0	11.4
0.497006	36.03	47.43	---	73.68	-26.25	100.0	O	259.0	11.4
0.638794	37.00	48.40	---	71.49	-23.09	100.0	O	82.0	11.4
0.892519	32.63	44.13	---	68.59	-24.47	100.0	O	62.0	11.5
1.149975	29.22	40.72	---	66.39	-25.67	100.0	O	75.0	11.5

- NOTES:
1. Peak Detector Data unless otherwise stated.
 2. All measurements were made at 3 meters.
 3. Negative value in the margin column shows emission below limit.
 4. Loop antenna is used for the emissions below 30MHz.
 5. Emissions within the restricted band meets the requirement of FCC Part 15 Section 15.205.
 6. Measurement Uncertainty is ±5.3dB at a level of confidence of 95%.
 7. Corr. (dB/m) = Antenna Factor (dB) + Cable Loss (dB)
Max Peak (dBµV/m) or Quasi-Peak (dBµV/m) = Corr. (dB/m) + Read Level (dBµV)
Margin (dB) = Max Peak (dBµV/m) – Limit (dBµV/m) or Quasi-Peak (dBµV/m) – Limit (dBµV/m)

TEST REPORT

RADIATED EMISSIONS

Model: HKWP21071-15L
Date of Test: September 12, 2024
Worst-Case Operating Mode: Standby Mode

Table 3
Pursuant to FCC Part 15 Section 15.209 Requirement

Frequency (MHz)	Read Level (dBμV)	MaxPeak (dBμV/m)	Limit (dBμV/m)	Margin (dB)	Height (cm)	Pol	Azimuth (deg)	Corr. (dB/m)
144.581250	12.27	22.37	43.50	-21.13	100.0	V	321.0	10.1
250.190000	11.46	25.76	46.00	-20.24	100.0	H	237.0	14.3
272.015000	9.37	23.97	46.00	-22.03	100.0	H	0.0	14.6
475.108750	3.88	24.38	46.00	-21.62	200.0	H	75.0	20.5
666.198750	3.82	28.62	46.00	-17.38	100.0	V	181.0	24.8
949.438750	2.73	30.53	46.00	-15.47	100.0	H	28.0	27.8

- NOTES:
1. Peak Detector Data unless otherwise stated.
 2. All measurements were made at 3 meters.
 3. Negative value in the margin column shows emission below limit.
 4. Loop antenna is used for the emissions below 30MHz.
 5. Emissions within the restricted band meets the requirement of FCC Part 15 Section 15.205.
 6. Measurement Uncertainty is ±5.3dB at a level of confidence of 95%.
 7. $Corr. (dB/m) = Antenna\ Factor (dB) + Cable\ Loss (dB)$
 $Max\ Peak (dB\mu V/m) \text{ or } Quasi-Peak (dB\mu V/m) = Corr. (dB/m) + Read\ Level (dB\mu V)$
 $Margin (dB) = Max\ Peak (dB\mu V/m) - Limit (dB\mu V/m) \text{ or } Quasi-Peak (dB\mu V/m) - Limit (dB\mu V/m)$

TEST REPORT

RADIATED EMISSIONS

Model: HKWP21071-15L
Date of Test: September 12, 2024
Worst-Case Operating Mode: Charging with Full Load

Table 4
Pursuant to FCC Part 15 Section 15.209 Requirement

Frequency (MHz)	Read Level (dBµV)	MaxPeak (dBµV/m)	Limit (dBµV/m)	Margin (dB)	Height (cm)	Pol	Azimuth (deg)	Corr. (dB/m)
56.190000	12.71	20.31	40.00	-19.69	200.0	V	178.0	7.6
79.833750	13.60	21.40	40.00	-18.60	100.0	V	317.0	7.8
192.111250	15.57	26.87	43.50	-16.63	100.0	V	104.0	11.3
250.917500	17.10	31.40	46.00	-14.60	100.0	H	242.0	14.3
288.020000	14.66	29.46	46.00	-16.54	100.0	H	28.0	14.8
362.710000	10.47	28.67	46.00	-17.33	100.0	H	258.0	18.2

- NOTES:
1. Peak Detector Data unless otherwise stated.
 2. All measurements were made at 3 meters.
 3. Negative value in the margin column shows emission below limit.
 4. Loop antenna is used for the emissions below 30MHz.
 5. Emissions within the restricted band meets the requirement of FCC Part 15 Section 15.205.
 6. Measurement Uncertainty is ±5.3dB at a level of confidence of 95%.
 7. Corr. (dB/m) = Antenna Factor (dB) + Cable Loss (dB)
 Max Peak (dBµV/m) or Quasi-Peak (dBµV/m) = Corr. (dB/m) + Read Level (dBµV)
 Margin (dB) = Max Peak (dBµV/m) – Limit (dBµV/m) or Quasi-Peak (dBµV/m) – Limit (dBµV/m)

TEST REPORT

4.0 EQUIPMENT PHOTOGRAPHS

For electronic filing, the photographs are saved with filename: external photos.pdf and internal photos.pdf.

5.0 PRODUCT LABELLING

For electronics filing, the FCC ID label artwork and the label location are saved with filename: label.pdf.

6.0 TECHNICAL SPECIFICATIONS

For electronic filing, the block diagram and schematic of the tested EUT are saved with filename: block.pdf and circuit.pdf respectively.

7.0 INSTRUCTION MANUAL

For electronic filing, a preliminary copy of the Instruction Manual is saved with filename: manual.pdf.

This manual will be provided to the end-user with each unit sold/leased in the United States.

TEST REPORT

8.0 MISCELLANEOUS INFORMATION

The miscellaneous information includes details of the test procedure and measured bandwidth.

8.1 Measured Bandwidth

Pursuant to FCC Part 15 Section 15.215(c), the 20dB bandwidth of the emission was contained within the frequency band designed (mentioned as above) which the EUT operated. The effects, if any, from frequency sweeping, frequency hopping, other modulation techniques and frequency stability over expected variations in temperature and supply voltage were considered.

8.2 Emissions Test Procedures

The following is a description of the test procedure used by Intertek Testing Services Hong Kong Ltd. in the measurements of transmitter operating under the Part 15, Subpart C rules.

The transmitting equipment under test (EUT) is placed on a wooden turntable which is four feet in diameter and approximately 0.8m in height above the ground plane for emission measurement at or below 1GHz and 1.5m in height above the ground plane for emission measurement above 1GHz. During the radiated emissions test, the turntable is rotated and any cables leaving the EUT are manipulated to find the configuration resulting in maximum emissions. The EUT is adjusted through all three orthogonal axis to obtain maximum emission levels. The antenna height and polarization are also varied during the testing to search for maximum signal levels. The height of the antenna is varied from one to four meters.

Detector function for radiated emissions is in peak mode. Average readings, when required, are taken by measuring the duty cycle of the equipment under test and subtracting the corresponding amount in dB from the measured peak readings. A detailed description for the calculation of the average factor can be found in Exhibit 8.3.

The frequency range scanned is from the lowest radio frequency signal generated in the device which is greater than 9 kHz to the tenth harmonic of the highest fundamental frequency or 40 GHz, whichever is lower. For line conducted emissions, the range scanned is 150 kHz to 30 MHz.

The EUT is warmed up for 15 minutes prior to the test.

AC power to the unit is varied from 85% to 115% nominal and variation in the fundamental emission field strength is recorded. If battery powered, a new, fully charged battery is used.

Conducted measurements were made as described in ANSI C63.10 (2013).

The IF bandwidth used for measurement of radiated signal strength was 100 kHz or greater when frequency is below 1000 MHz. Where pulsed transmissions of short enough pulse duration warrant, a greater bandwidth is selected according to the recommendations of Hewlett Packard Application Note 150-2. A discussion of whether pulse desensitivity is applicable to this unit is included in this report (See Exhibit 8.1). Above 1000 MHz, a resolution bandwidth of 1 MHz is used.

Transmitter measurements are normally conducted at a measurement distance of three meters. However, to assure low enough noise floor in the forbidden bands and above 1 GHz, signals are acquired at a distance of one meter or less. All measurements are extrapolated to three meters using inverse scaling, unless otherwise reported. Measurements taken at a closer distance are so marked.

TEST REPORT

8.2.1 Radiated Emission Test Setup

The figure below shows the test setup, which is utilized to make these measurements.

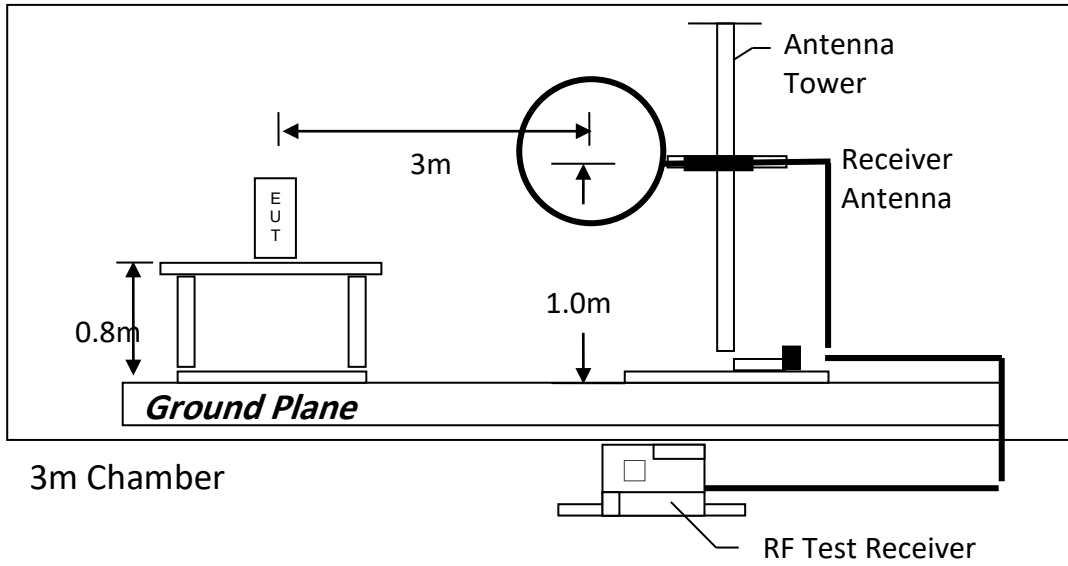

Test setup of radiated emissions up to 30MHz

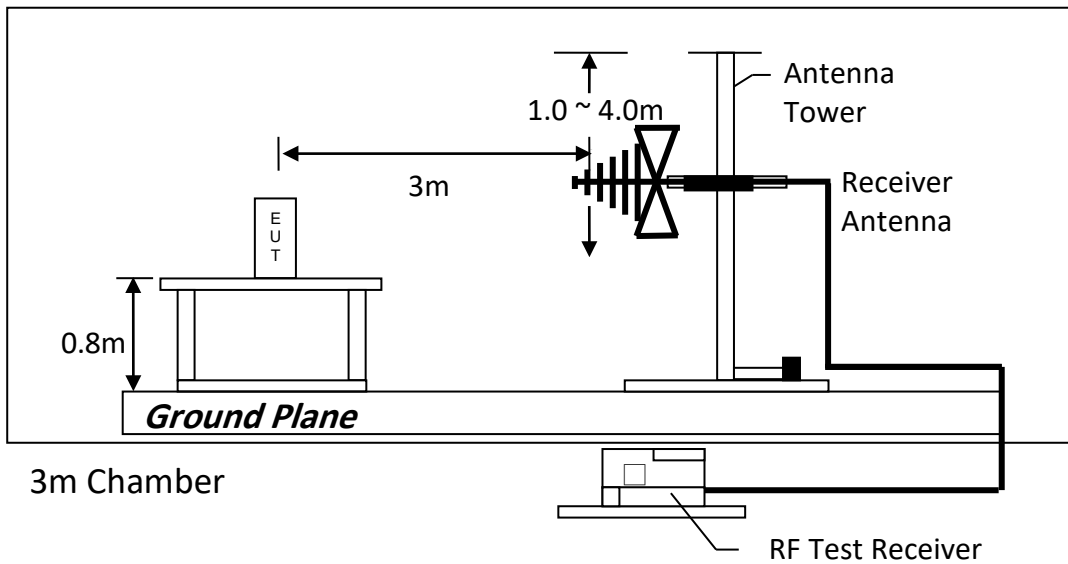

Test setup of radiated emissions above 1GHz

TEST REPORT

8.2.2 Conducted Emission Test Procedures

For tabletop equipment, the EUT along with its peripherals were placed on a 1.0m(W)×1.5m(L) and 0.8m in height wooden table. For floor-standing equipment, the EUT and all cables were insulated, if required, from the ground plane by up to 12 mm of insulating material. The EUT was adjusted to maintain a 0.4 meter space from a vertical reference plane. The EUT was connected to power mains through a line impedance stabilization network (LISN), which provided 50 ohm coupling impedance for measuring instrument and the chassis ground was bounded to the horizontal ground plane of shielded room. The excess power cable between the EUT and the LISN was bundled.

All connecting cables of EUT and peripherals were moved to find the maximum emission.

8.2.3 Conducted Emission Test Setup

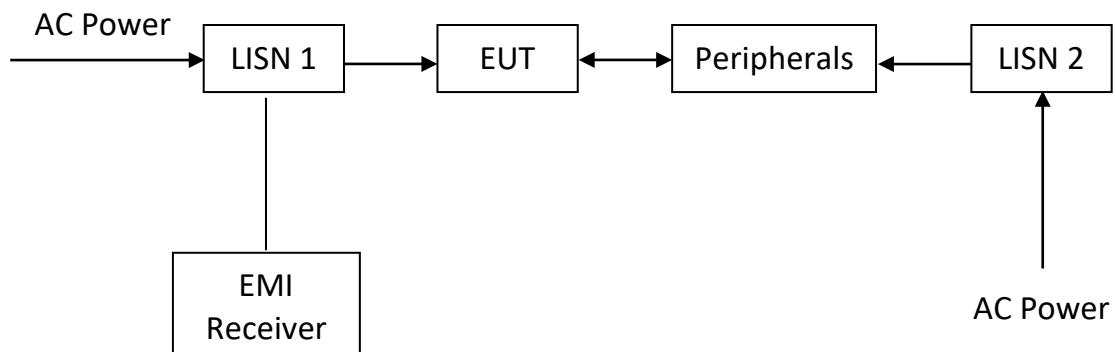

TEST REPORT

Occupied Bandwidth Results: Charging with Full Load

Frequency (kHz)	Occupied Bandwidth (Hz)
357	12200

The worst case is shown as below

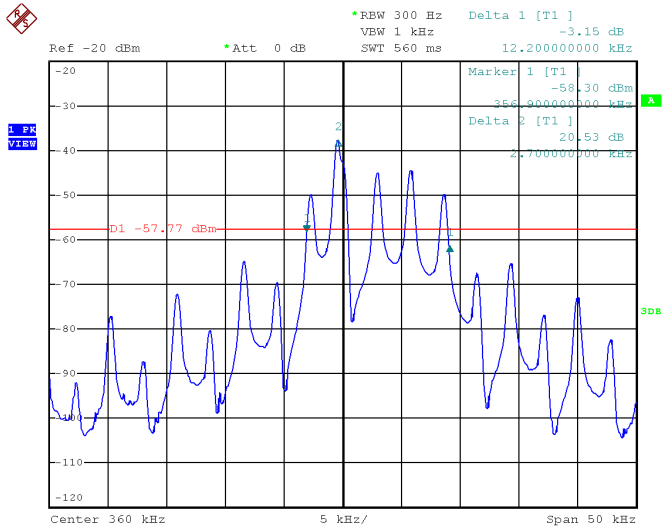

TEST REPORT

9.0 CONFIDENTIALITY REQUEST

For electronic filing, a preliminary copy of the confidentiality request is saved with filename: request.pdf.

10.0 EQUIPMENT LIST

1) Radiated Emissions Test

Equipment	EMI Test Receiver (9kHz to 26.5GHz)	Biconical Antenna (30MHz to 300MHz)	Log Periodic Antenna
Registration No.	EW-3156	EW-3242	EW-3243
Manufacturer	ROHDESCHWARZ	EMCO	EMCO
Model No.	ESR26	3110C	3148B
Calibration Date	January 31, 2024	July 30, 2024	July 30, 2024
Calibration Due Date	January 31, 2025	July 30, 2026	January 30, 2026

Equipment	Double Ridged Guide Antenna (1GHz - 18GHz)	Active Loop Antenna (H-field) (9kHz to 30MHz)	RF Pre-amplifier (9kHz to 6000MHz)
Registration No.	EW-0194	EW-3326	EW-3006b
Manufacturer	EMCO	EMCO	SCHWARZBECK
Model No.	3115	6502	BBV9718
Calibration Date	May 10, 2023	January 05, 2024	October 20, 2023
Calibration Due Date	November 10, 2024	July 05, 2025	October 20, 2024

Equipment	14m Double Shield RF Cable (9kHz - 6GHz)	RF Cable 14m (1GHz to 26.5GHz)	12 metre RF Cable (1-40)GHz
Registration No.	EW-2376	EW-2781	EW-2774
Manufacturer	RADIALL	GREATBILLION	GREATBILLION
Model No.	n m/br56/bnc m 14m	SMA m/SHF5MPU /SMA m ra14m,26G	SMA m-m ra 12m 40G outdoor
Calibration Date	September 19, 2023	January 16, 2024	January 16, 2024
Calibration Due Date	September 19, 2024	January 16, 2025	January 16, 2025

Equipment	Pyramidal Horn Antenna
Registration No.	EW-0905
Manufacturer	EMCO
Model No.	3160-09
Calibration Date	December 15, 2023
Calibration Due Date	June 15, 2025

TEST REPORT

2) Conducted Emissions Test

Equipment	RF Cable 240cm (RG142) (9kHz to 30MHz)	Artificial Mains Network	EMI Test Receiver (9kHz to 3GHz)
Registration No.	EW-2454	EW-3360	EW-3095
Manufacturer	RADIALL	ROHDESCHWARZ	ROHDESCHWARZ
Model No.	Bnc m st / 142 / bnc mra 240cm	ENV-216	ESCI
Calibration Date	June 20, 2024	April 07, 2024	January 18, 2024
Calibration Due Date	June 20, 2025	April 07, 2025	January 18, 2025

3) OBW Measurement

Equipment	EMI Test Receiver (9kHz to 3GHz)
Registration No.	EW-3095
Manufacturer	ROHDESCHWARZ
Model No.	ESCI
Calibration Date	January 18, 2024
Calibration Due Date	January 18, 2025

4) Control Software for Radiated Emission

Software Information	
Software Name	EMC32
Manufacturer	ROHDESCHWARZ
Software version	10.50.40

END OF TEST REPORT