

VLP-500 series

Label Printing Scale

SERVICE OPERATION MANUAL

Designed for weighing and label printing in supermarkets, groceries, and other retail stores, the VLP-500 series Touch Screen Label Printing Scale, delivers crisp, easy to read labels for all users.

Graphics are colorful & using convenient with the responsive 10.1-inch Touch Display.

SHANGHAI DIGITAL BALANCE ELECTRONIC CO., LTD.

Ver1.0 2025.2

Catalogue

1. GENERAL	1
1.1 Precautions	1
1.2 Introductions	3
1.3 Specifications	3
1.4 Name and Functions	4
1.5 Symbols	8
1.6 Key Functions	9
1.7 Installation of the Label Roll	12
1.8 Power ON/OFF	17
1.9 Touch Screen Calibration	18
1.10 Internal Code	20
1.11 Program Update	21
1.12 Initialize Date	22
1.13 Customize the Assignment Key	23
1.14 PLU Editor	24
1.15 Language	24
1.16 Set Date and Time	24
2. PROGRAMMING	25
2.1 PLU Programming	25
2.1.1 MODIFY THE LIST OF COMMODITY	26
2.2 PLU Date Table	30
2.2.1 Shop Name	31
2.2.2 Department	32
2.2.3 Main Group	32
2.2.4 Place of Origin	32
2.3 Discount	33
2.4 Global Discount Programming	33
2.5 Speedkey Setting	34
2.6 County Programming	36
2.7 Global Setting	37
2.8 Printing Programming	42
2.9 Scale Configuration	44
2.10 Network Configuration	44
2.11 Using the Icon	44
2.12 About	45
3. SALES OPERATION	46
3.1 Basic Operation	46
3.2 Zero	47
3.3 Tare	48
3.4 Calling Up a PLU	49
3.5 Override	50
3.5.1 By-Weight PLU	50

3.5.2 By Non-Weight PLU	52
3.5.3 By Count PLU	53
3.6 Discount	54
3.7 Prepack Key	55
3.8 X Key	55
3.9 How to Change Sell By Date/Time	56
3.10 How to Change Origin	56
3.11 How to Change PLU Type	57
3.12 How to set Network	57
3.13 PLU Search	60
3.14 How to Backup Data	61
3.15 How to Restore Data	63
4. APPENDIX	65
4.1 Label Format	65

1. GENERAL

1.1 Precautions



Please follow the instructions below to operate the product to ensure product and personal safety.

Before installation, it is important to check whether the power supply indicated by the brand name matches to ensure the normal operation of the machine.

Keep your fingers dry when inserting or removing the power plug to avoid electric shock.

Sharing sockets with other highpower devices can cause large fluctuations. Make sure that one scale uses a matching power outlet.

Metal objects or liquids can cause fire or rust in the scale. Keep an appropriate distance from the scale to avoid damage.

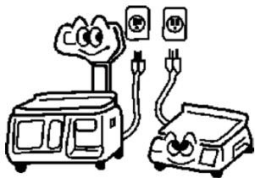

Do not insert metal or flammable object sat the interface to avoid damage to the machine or fire.

Do not scratch or modify the power cord, bend excessively or place heavy objects on top to avoid fire or short circuit.

If the scale falls, please turn off the switch and power plug immediately, suspend use, and contact the service personnel in time to avoid fire or electric shock.

When the scale emits smoke or strange smell, please stop using it immediately, turn off the switch and power supply, and contact the service personnel in time.



Immediately turn off the switch and plug when metal fragments or liquids enter the interior, suspend use and contact service personnel to avoid fire or electric shock.

To avoid disconnection of the power cord or peeling of the cord when unplugging the power cord, do not pull on the cord.

Make sure that the scale and extension cable are properly grounded, as this can cause external metal parts to be electrostatically charged to prevent fire or electric shock.

Do not remove, repair or modify the scale body, highvoltage, high-heat parts or internal edgestoen sure personal safety.

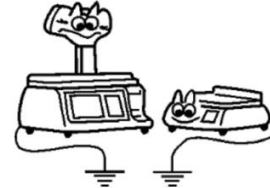
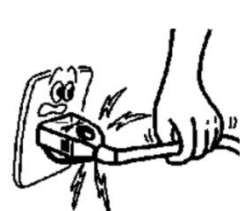

PRECAUTIONS

Please follow the prompts to extend the life.

Please avoid placing the product in the following locations:

- 1.If the temperature is too high or too low, direct sunlight, wet place;
- 2.At the shared power supply, excessive vibration, dust, and moisture.
- 3.Do not press the button too hard, please touch the button.
- 4.Do not suddenly bump into the machine to avoid damaging the load cell.
- 5.Do not press the center of gravity on the weighing platform to avoid damage to the load cell.
- 6.To clean the weighing pan and keyboard, use a dry cloth and wipe with a detergent. Do not use thinner or other volatile solvents.
- 7.In order to ensure the normal use of the scale, before starting the operation every day, adjust the level and lock the foot nut, and place a known weight of the item on the weighing platform to check the weighing of the scale.
- 8.Do not place the instrument on an unstable or inclined surface to avoid dropping.

9.Use standard thermal paper to store thermal paper under direct sunlight, high

temperatures, dust, or moisture.

10.When the mechanical equipment is moved to a higher temperature in a place with a lower temperature (such as a refrigerating room), because the temperature difference is large, the power supply cannot be turned on immediately to prevent the condensation of the water vapor and cause damage to the machine.

11.Keep one socket and one machine, avoiding high voltage or equipment that may cause power interference.

12.Thermal print head failure is not covered by the warranty. Please use and maintain the equipment properly according to the instructions or service personnel's recommendations.

13.Do not use the long-distance line of the power plug of the scale. Be sure to keep it in the AC socket. Keep the hand dry when pulling the plug. Excessive bending and pulling will damage the power cord and cause fire or electric shock.

1.2 Introductions

Touch Screen Label Printing Scale designed for weighing and label printing in supermarkets, groceries, and other retail stores, the VLP-500 series Touch Screen Label Printing Scale, delivers crisp, easy to read labels for all users.

Graphics are colorful & using convenient with the responsive 10.1-inch Touch Display.

1.3 Specifications

Models	VLP-500P	VLP-500B	VLP-500R	VLP-500RP
Display Font	10/12/15inch	10/12/15inch	10/12/15inch	10/12/15inch
Customer Rear	7/10inch	7/10inch	7/10inch	7/10inch
Resolution	7'(1024x600) / 10'(1280x800) / 12'(1024x768) / 15'(1366x768)			
Display Type	TFT WVGA, touch screen			
Capacity	6lb; 15lb; 30lb; 60lb; 15/30lb; 30/60lb			
Memory	2 GB DDR3 SDRAM 8GHz			
Interface	1 Ethernet 10/100 Base T, 2 USB 2.0, 1 RJ11, 1 wireless LAN IEEE 802.11 a / b / g / n			
Printing Speed(mm/sec)	100			
Label Size(mm)	Label paper printing max width 56mm, length 350mm; Receipt paper printing max width 56mm, length ≤90mm			
Operation Temperature(°F/°C)	0 ° C ~ 40 ° C (32 ° F ~ 104 ° F)			
Power	AC 94V-242V, 50/60Hz			
Platter Size(in/mm)(WxD)	14.2x11.8 / 360x300(304 stainless steel)			
Dimensions(in/mm)(WxDxH)	14.9x16.6x19.5 / 378x422x497			
Product Weight(lbs/kg)	25.5 / 11.5			
Ship Weight(lbs/kg)	28.5 / 12.9			
Warranty	One year			

1.4 Name and Functions

Overall View

VLP-500P

VLP-500B

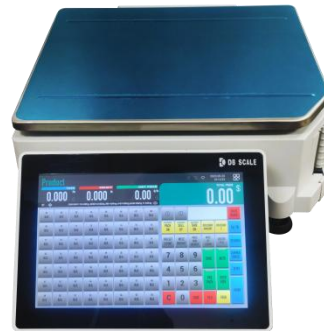

VLP-500R

VLP-500RP

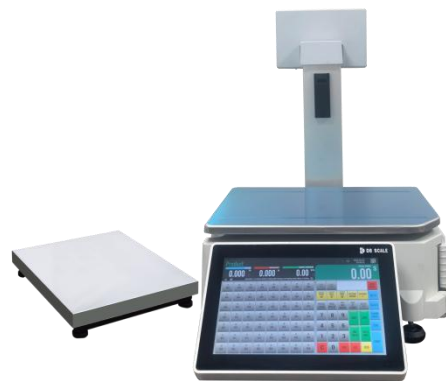

Display(KEY)

Front display for the operator(KEY 1)

Product Name

KEY 1

2021.06.19 10:55

TARE lb WEIGHT lb UNIT PRICE \$/lb TOTAL PRICE

0.000 0.000 0.00 \$ 0.00

DISABLE PRINTING TARE ZERO

STABLE *0* NET CAPA: MAX= 60 / 30 lb , MIN= 0.2 lb e=d= 0.02 / 0.01 lb, T= -29.99 lb

01 PLU Name	02 PLU Name	03 PLU Name	04 PLU Name	05 PLU Name	06 PLU Name	07 PLU Name	08 PLU Name	MENU	PLU Editor	TOOL	SCALE INFO.	TARE		
09 PLU Name	10 PLU Name	11 PLU Name	12 PLU Name	13 PLU Name	14 PLU Name	15 PLU Name	16 PLU Name	PAGE UP ↑	PAGE DOWN ↓	SEARCH	PRE PACK	FEED		
17 PLU Name	18 PLU Name	19 PLU Name	20 PLU Name	21 PLU Name	22 PLU Name	23 PLU Name	24 PLU Name	7	8	9	SAVE	OVER RIDE		
25 PLU Name	26 PLU Name	27 PLU Name	28 PLU Name	29 PLU Name	30 PLU Name	31 PLU Name	32 PLU Name	4	5	6	AUTO	X		
33 PLU Name	34 PLU Name	35 PLU Name	36 PLU Name	37 PLU Name	38 PLU Name	39 PLU Name	40 PLU Name	1	2	3	PRINT			
41 PLU Name	42 PLU Name	43 PLU Name	44 PLU Name	45 PLU Name	46 PLU Name	47 PLU Name	48 PLU Name	C	0	PLU	PRINT			
49 PLU Name	50 PLU Name	51 PLU Name	52 PLU Name	53 PLU Name	54 PLU Name	55 PLU Name	56 PLU Name						PRINT	

Front display for the operator(KEY 2)

Product Name

KEY 2

2021.06.19 10:55

TARE lb WEIGHT lb UNIT PRICE \$/lb TOTAL PRICE

0.000 0.000 0.00 \$ 0.00

DISABLE PRINTING TARE ZERO

STABLE *0* NET CAPA: MAX= 60 / 30 lb , MIN= 0.2 lb e=d= 0.02 / 0.01 lb, T= -29.99 lb

01 Shaanxi FUJI APPLE	02 PLU Name	03 PLU Name	04 PLU Name	05 PLU Name	MENU	PLU Editor	TOOL	SCALE INFO.	TARE	
06 PLU Name	07 PLU Name	08 PLU Name	09 PLU Name	10 PLU Name	PAGE UP ↑	PAGE DOWN ↓	SEARCH	PRE PACK	FEED	
11 PLU Name	12 PLU Name	13 PLU Name	14 PLU Name	15 PLU Name	7	8	9	SAVE	OVER RIDE	
16 PLU Name	17 PLU Name	18 PLU Name	19 PLU Name	20 PLU Name	4	5	6	AUTO	X	
					1	2	3	PRINT		
					C	0	PLU	PRINT		

Front display for the operator(KEY 3)

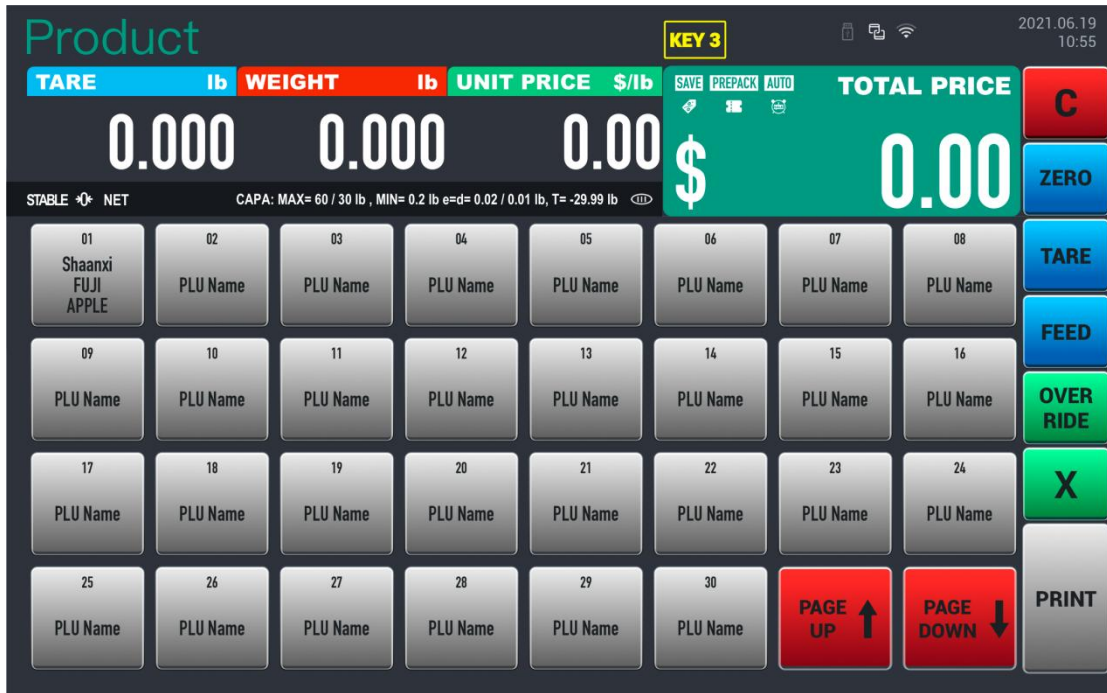

Front display for the operator(KEY 4)

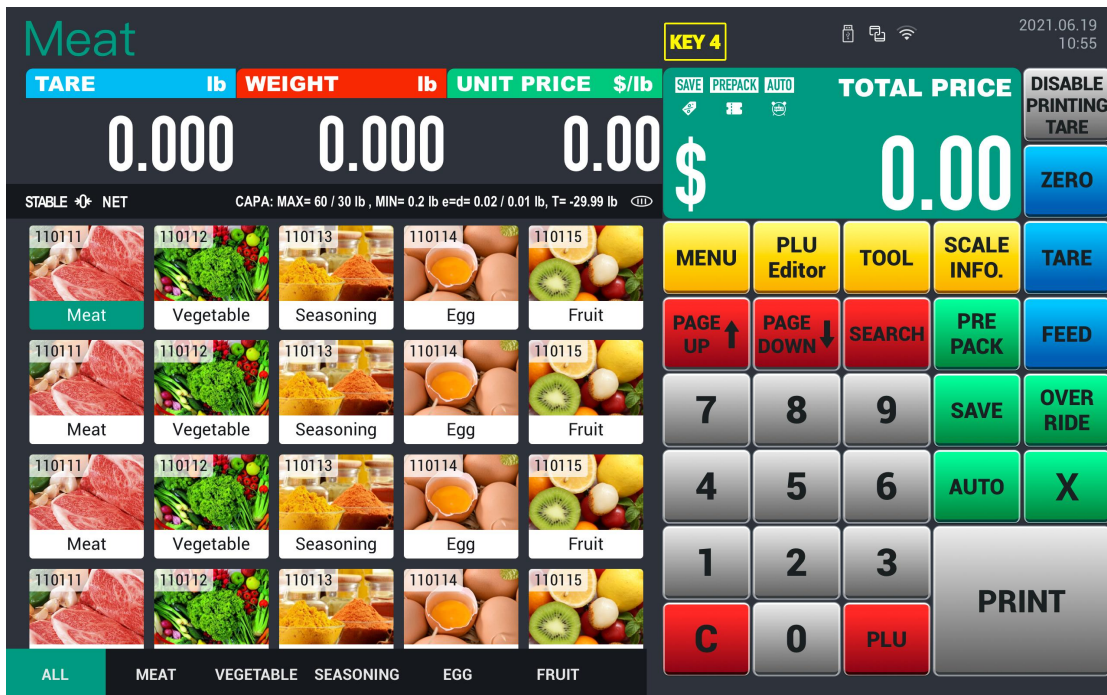

Front display for the operator(KEY 5)

Product KEY 5 2021.06.19
10:55

TARE	lb	WEIGHT	lb	UNIT PRICE	\$/lb	TOTAL PRICE
0.000		0.000		0.00	\$	0.00

STABLE \pm NET CAPA: MAX= 60 / 30 lb , MIN= 0.2 lb e=d= 0.02 / 0.01 lb, T= -29.99 lb

110111 Meat	110112 Vegetable	110113 Seasoning	110114 Egg	110115 Fruit	110111 Meat	110112 Vegetable	110113 Seasoning	C ZERO TARE FEED OVER RIDE X PRINT
110111 Meat	110112 Vegetable	110113 Seasoning	110114 Egg	110115 Fruit	110111 Meat	110112 Vegetable	110113 Seasoning	
110111 Meat	110112 Vegetable	110113 Seasoning	110114 Egg	110115 Fruit	110111 Meat	PAGE UP \uparrow PAGE DOWN \downarrow		

ALL MEAT VEGETABLE SEASONING EGG FRUIT PASTRY

Back display for customers

Peach 2023.09.06 10:55

TARE	lb	WEIGHT	lb	UNIT PRICE	\$/lb	TOTAL PRICE
0.000		1.000		8.00	\$	8.00

ST \pm NET CAPA: MAX1=60 x 0.02 lb, MAX2=30 x 0.01 lb, MIN=0.2 lb e1=d1=0.02 lb, e2=d2=0.01 lb, T=-59.98 lb

Name:

Item Code: _____

Packing Date: 2023-9-6

Sales Date: 2023-9-6







Ingredient List: _____

www.VisionTechShop.com

VISION **TECH**
SHOP





 **DB SCALE**

1.5 Symbols

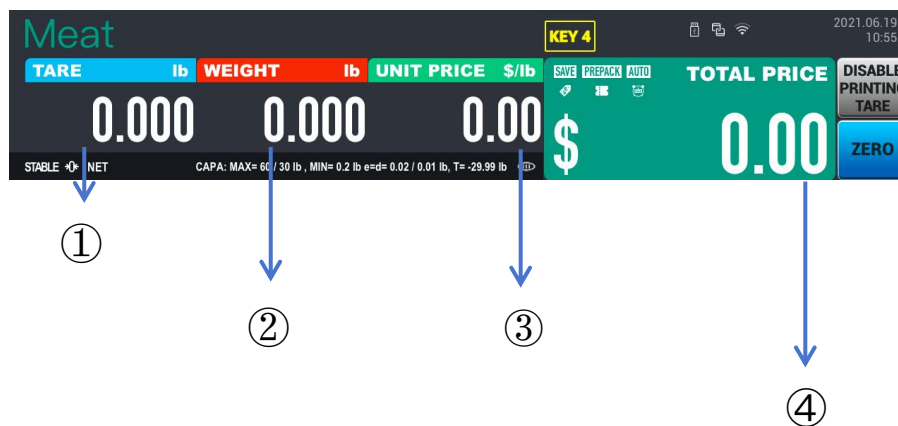
SYMBOLS	DESCRIPTION
TYPE	
	Zero indicator
	Stability indicator
	Net indicator
	USB indication
	Wired network indication
	Wi-Fi





















Numeric display field





No.	Image	Name	Description
1		Tare column	
2		Weighing column	
3		Unit price column	
4		Total price column	







1.6 Key Functions





Function key

KEY	DESCRIPTION
	Shortcut keys mode
	Basic mode
	Extended mode
	Picture mode
	Multigraph model
	Search key
	Shortcut key Page turning key
	MENU key. This key toggles from program menu to sale mode.
	PLU Editor key
	Tool key
	Scale info. key
	Custom key
	Re-Zero key. Use to remove small variations in the scale's zero.
	Tare key. Use to manually enter and remove tare weights.
	Feed key. Use this key to feed labels or paper through printer
	Pre-Pack key. Used to enter Pre-Packaging mode in which the scale Auto-prints for every transaction and prevents the auto clearing of data.
	Save key. Save mode prevents the auto clearing of any called-up data like tare weight, PLU pricing, etc.
	Override key. For temporary price change entry.
	AUTO key. Auto-print mode
	Multi-Label key. Use this key to print multiple sales of the same transaction.

	Clear key. Used to clear erroneous entries and error conditions.
	PLU key
	Print key. Used to manually print transactions and also serves as an ENTER key in programming mode. There are 2 of them and they both act the same.

Tool key

KEY	DESCRIPTION
	Global packed on sell by
	Print packed on date
	Print sell by date
	Disable printing tare
	Enable \$100
	Global label format off
	Discount amount
	Discount %

	Miscellaneous Weighed PLU key.
	Miscellaneous Non-weighed PLU key.
	Miscellaneous By-Count PLU key.
	Select label format
	Reprint

1.7 Installation of the Label Roll

- Receipt Paper Specifications

Length(x) range: $25\text{mm} \leq x \leq 200\text{mm}$

Width(y) range: $25\text{mm} \leq y \leq 58\text{mm}$

Diameter(R) range: $R \leq 80\text{mm}$

Default paper width: 56mm

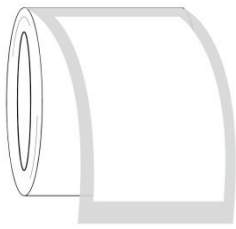

- Label Paper Specifications

Length(x) range: $25\text{mm} \leq x \leq 200\text{mm}$

Width(y) range: $25\text{mm} \leq y \leq 58\text{mm}$

Diameter(R) range: $R \leq 100\text{mm}$

Default paper width: 60mm

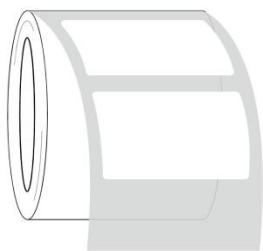

• To install the label roll at ANY time you must follow the directions in the section:

STEP	DESCRIPTION
------	-------------

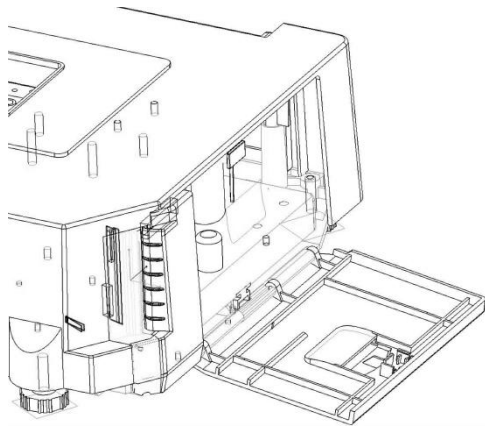

Open the roll tray door on the left side of the electronic scale;

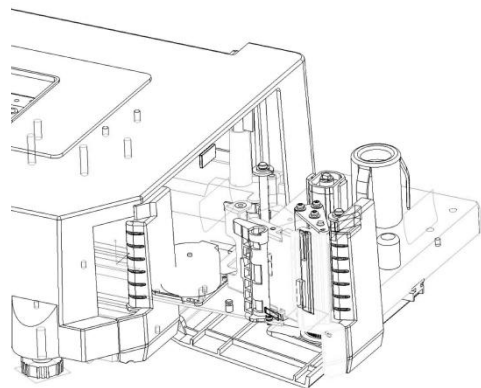

Fingers hold the two grooves and pull out the roll paper box;

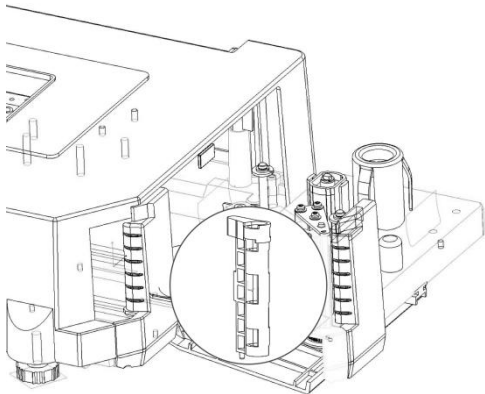

Hold the buckle and rotate it;

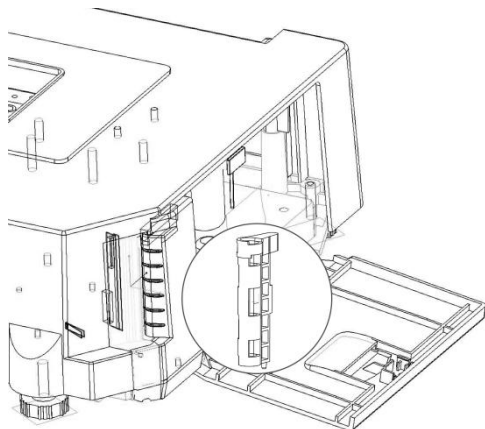

Rotate counterclockwise about 45 degrees;

Clamp the white column at the beginning of the roll paper, and the roll paper portion is unfolded around the opening;

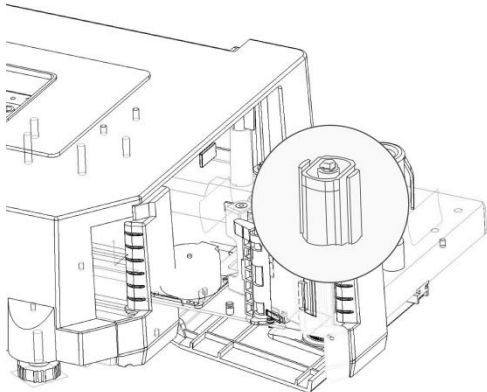



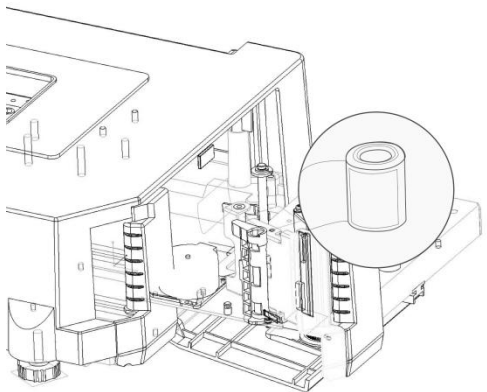

The label paper or receipt paper is placed on the right side of the cylinder, and the paper box is pushed into the machine to close the side door.

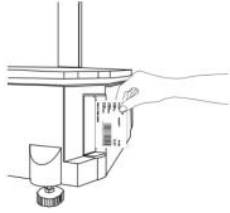

After the volume tray is installed, the hardware part is installed.

• Hints

HINTS	DESCRIPTION
<p data-bbox="427 297 847 327">⚠ Please remove the label ❌</p> 	<p data-bbox="1098 416 1316 445">Please remove the label</p>
<p data-bbox="427 598 847 627">⚠ Please close the printer head ❌</p> 	<p data-bbox="1074 719 1340 748">Please close the printer head</p>
<p data-bbox="427 898 847 927">⚠ Lack of paper ❌</p> 	<p data-bbox="1142 1021 1272 1050">Lack of paper</p>
<p data-bbox="427 1198 847 1227">⚠ Please press Feed key ❌</p>  <p data-bbox="679 1451 699 1473">A</p>	<p data-bbox="1102 1323 1311 1352">Please press Feed key</p>

1.8 Power ON/OFF

P-TYPE

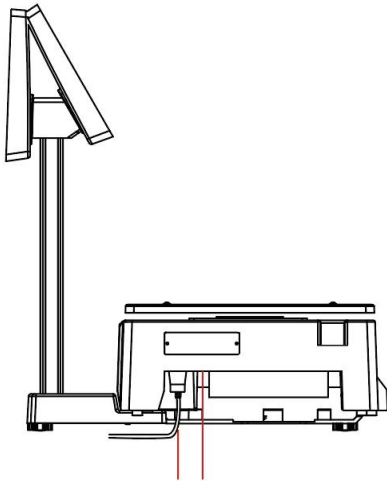

Power supply Switch button

After inserting the power plug, press the switch button to turn on;
Swipe up and down the screen to find the "DB Scale" app icon, and click to enter.

1.9 Touch Screen Calibration

Menu→Settings→Calibration

Step 1

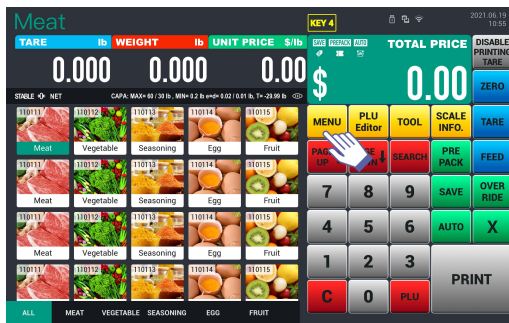

Step 2



Step 3

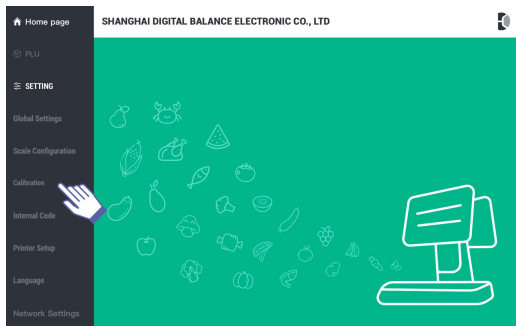

Step 4

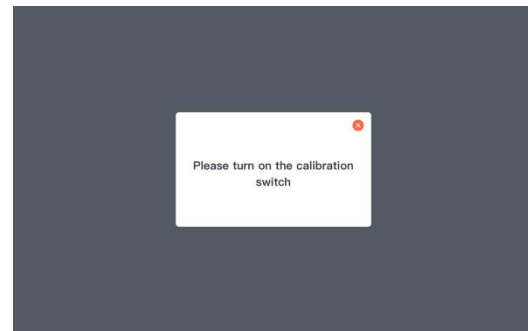

Step 5

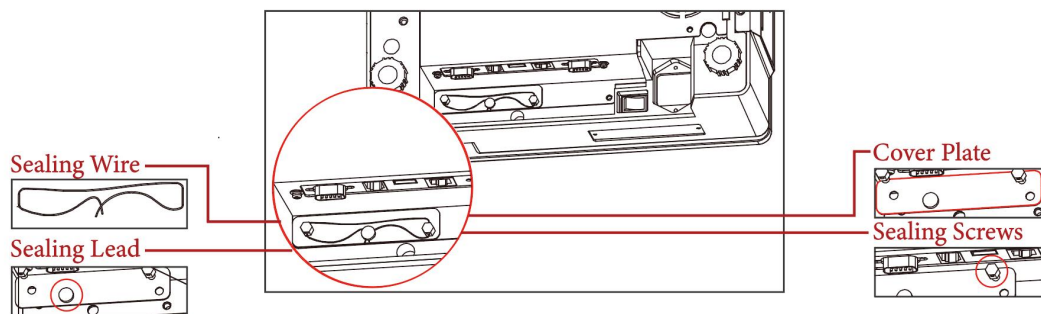

Open the bottom seal, and click the bottom calibration switch with a slender object.

Step 6



Please input calibration weight during calibration.

When the calibration is full, go directly to the next step. The calibration value should not be less than 10% of the maximum weighing.

Step 7

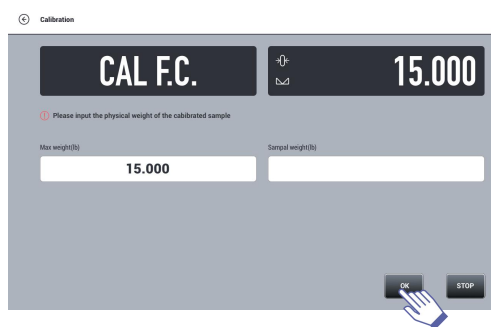

Step 8



Step 9

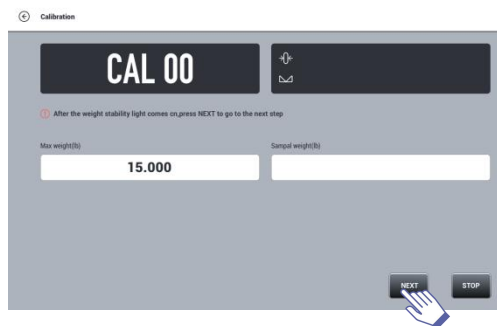

Step 10



Place the object with set weight on the weighing platform, and press the NEXT button to perform full volume calibration after the weight stability light is on.

Step 11

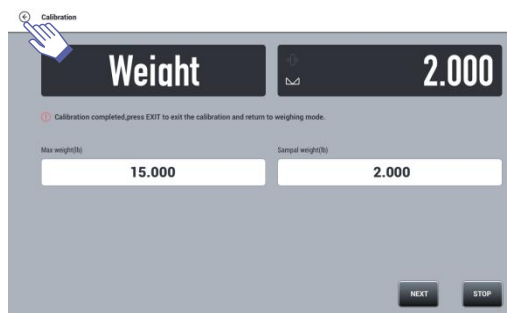

After calibration, shut down and restart.

1.10 Internal Code

Menu→Settings→Internal Code

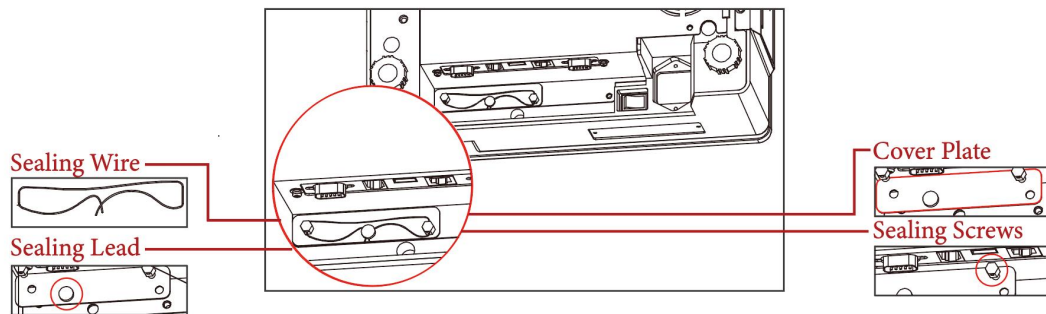

Open the bottom seal, and click the bottom calibration switch with a slender object.

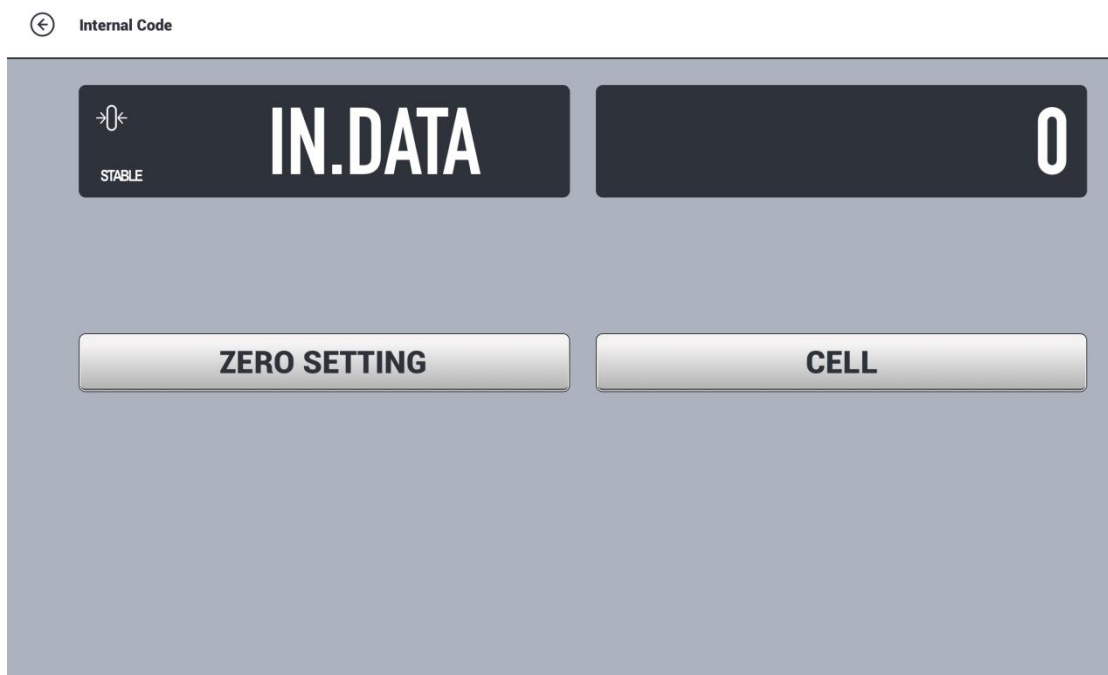

1.11 Program Update

- By USB Memory

Menu→PLU→PLU List→Import

1. Fill in the imported goods through the special form:

MainGroup	PLU/NO	Property	ItemCode	Name	BU/NO	F1/2	Price	Max price	VIP price	Cost price	Measuring unit	Label PHT	Label PHT2	BCD. PHT	BCD. PHT2	TAKNO	State	Tax No	Time	QTY	Shelf life day	Sale date	Sale time	Pack date	Pack time	Ingr	
1	2	0	2	Chinese cabbage	2.png	35	12.36	0	0	0	6	5	0	0	2				0	11	10	2	0	0	2	24	curd with up to 35%solution of water_sodium_phosphate_sodium pythorbo
1	4	1	4	Lettuce	4.png	35	5.96	0	0	0	6	5	0	0	2				0	0	1	1	0	0	0	0	
1	5	2	5	Cabbage	5.png	35	4.36	0	0	0	6	5	0	0	2				0	0	0	0	0	0	0	0	
1	6	0	6	Bulk Chef Little Anko Bay Meat Leaf KG	6.png	29	35.6	0	0	0	6	5	0	0	2				0	0	0	0	0	0	0	0	
1	7	1	7	Cabbage	7.png	29	3.36	0	0	0	6	51	0	0	2				0	0	0	0	0	0	0	0	
1	8	2	8	Celery	8.png	29	4.36	0	0	0	6	51	0	0	2				0	0	0	0	0	0	0	0	
1	10	0	10	Browned sprouts	10.png	29	1.98	0	0	0	6	5	0	0	2				0	0	0	0	0	0	0	0	
1	11	0	11	Quality broccoli	11.png	29	9.16	0	0	0	6	51	0	0	2				0	0	0	0	0	0	0	0	
1	12	0	12	Old Pumpkin	12.png	29	1.96	0	0	0	6	51	0	0	2				0	0	0	0	0	0	0	0	
1	13	0	13	Quality cucumber	13.png	29	3.10	0	0	0	6	51	0	0	2				0	0	0	0	0	0	0	0	
1	14	0	14	Dried Pepper in bulk	14.png	29	47.8	0	0	0	6	51	0	0	2				0	0	0	0	0	0	0	0	
1	15	0	15	Local cucumber KG	15.png	29	4.56	0	0	0	6	51	0	0	2				0	0	0	0	0	0	0	0	
1	16	0	16	Local leaflet	16.png	29	3.36	0	0	0	6	51	0	0	2				0	0	0	0	0	0	0	0	
1	17	0	17	Quality tomatoes	17.png	29	3.96	0	0	0	6	51	0	0	2				0	0	0	0	0	0	0	0	
1	18	0	18	Jiangxi (green bean)	18.png	29	5.96	0	0	0	6	51	0	0	2				0	0	0	0	0	0	0	0	
1	20	0	20	White cowpea	20.png	29	4.96	0	0	0	6	51	0	0	2				0	0	0	0	0	0	0	0	
1	22	0	22	Quality carrots	22.png	29	2.16	0	0	0	6	51	0	0	2				0	0	0	0	0	0	0	0	
1	23	0	23	Yam	23.png	29	5.96	0	0	0	6	51	0	0	2				0	0	0	0	0	0	0	0	
1	24	0	24	Quality onion	24.png	29	3.36	0	0	0	6	51	0	0	2				0	0	0	0	0	0	0	0	
1	25	0	25	Garlic	25.png	29	9.76	0	0	0	6	51	0	0	2				0	0	0	0	0	0	0	0	
1	26	0	26	High quality rose sprouts	26.png	29	2.36	0	0	0	6	51	0	0	2				0	0	0	0	0	0	0	0	
1	28	0	28	High quality fungus	28.png	29	2.76	0	0	0	6	51	0	0	2				0	0	0	0	0	0	0	0	
1	30	0	30	Shiitake mushrooms	30.png	29	17.96	0	0	0	6	51	0	0	2				0	0	0	0	0	0	0	0	
1	32	0	32	Wu Men Jiang Dong KG	32.png	29	15.6	0	0	0	6	51	0	0	2				0	0	0	0	0	0	0	0	
1	35	0	35	Help in bulk	35.png	29	17.56	0	0	0	6	51	0	0	2				0	0	0	0	0	0	0	0	
1	38	0	38	Lions Vegetable	38.png	29	7.96	0	0	0	6	51	0	0	2				0	0	0	0	0	0	0	0	
1	39	0	39	Li Zaohe Ma Yu KG	39.png	29	5.16	0	0	0	6	51	0	0	2				0	0	0	0	0	0	0	0	
1	40	0	40	Li Jia Zhai Zhong pieces KG	40.png	29	13.16	0	0	0	6	51	0	0	2				0	0	0	0	0	0	0	0	
1	42	0	42	Earth Pot	42.png	29	13.96	0	0	0	6	51	0	0	2				0	0	0	0	0	0	0	0	
1	46	0	46	Shanghai Crystal Fuj 75	46.png	29	7.96	0	0	0	6	51	0	0	2				0	0	0	0	0	0	0	0	
1	47	0	47	High quality Shuang Crystal Fuj 80	47.png	29	13.16	0	0	0	6	51	0	0	2				0	0	0	0	0	0	0	0	
1	48	0	48	Gala 65-70	48.png	29	4	0	0	0	6	51	0	0	2				0	0	0	0	0	0	0	0	
1	49	0	49	High quality flower cattle apple	49.png	29	7.96	0	0	0	6	51	0	0	2				0	0	0	0	0	0	0	0	
1	51	0	51	Shanghai Crystal Fuj 75	51.png	29	9.36	0	0	0	6	51	0	0	2				0	0	0	0	0	0	0	0	
1	52	0	52	Shanghai Crystal Fuj 80	52.png	29	9.96	0	0	0	6	51	0	0	2				0	0	0	0	0	0	0	0	
1	53	0	53	Apple Apple	53.png	29	3.76	0	0	0	6	51	0	0	2				0	0	0	0	0	0	0	0	
1	55	0	55	Crystal Pear	55.png	29	9.96	0	0	0	6	51	0	0	2				0	0	0	0	0	0	0	0	
1	56	0	56	High quality crown pears	56.png	29	7.96	0	0	0	6	51	0	0	2				0	0	0	0	0	0	0	0	
1	57	0	57	Noria Pear	57.png	29	7.96	0	0	0	6	51	0	0	2				0	0	0	0	0	0	0	0	
1	58	0	58	Redness	58.png	29	5.96	0	0	0	6	51	0	0	2				0	0	0	0	0	0	0	0	
1	59	0	59	Red is not soft peach	59.png	29	4.56	0	0	0	6	51	0	0	2				0	0	0	0	0	0	0	0	
1	60	0	60	Winter Jujube in Dal County, Shaanxi Province	60	29	0	0	0	0	6	0	0	0	2				0	0	0	0	0	0	0	0	
1	61	0	61	Black Stone	61.png	29	5.16	0	0	0	6	51	0	0	2				0	0	0	0	0	0	0	0	
1	62	0	62	The Emperor	62.png	29	4	0	0	0	6	51	0	0	2				0	0	0	0	0	0	0	0	
1	63	0	63	Haifeng County Tangerine	63.png	29	6	0	0	0	6	51	0	0	2				0	0	0	0	0	0	0	0	
1	64	0	64	Good quality oranges	64.png	29	2	0	0	0	6	51	0	0	2				0	0	0	0	0	0	0	0	
1	65	0	65	High quality super orange	65.png	29	6	0	0	0	6	51	0	0	2				0	0	0	0	0	0	0	0	
1	66	0	66	High Tangerine in Yunnan	66.png	29	5.96	0	0	0	6	51	0	0	2				0	0	0	0	0	0	0	0	
1	68	0	68	Shou Prefecture Orange	68.png	29	15.16	0	0	0	6	51	0	0	2				0	0	0	0	0	0	0	0	
1	69	0	69	Honey grapefruit with a red heart	69.png	29	5.16	0	0	0	6	51	0	0	2				0	0	0	0	0	0	0	0	
1	70	0	70	Guanni honey pomelo	70.png	29	3.56	0	0	0	6	51	0	0	2				0	0	0	0	0	0	0	0	

Picture folder:

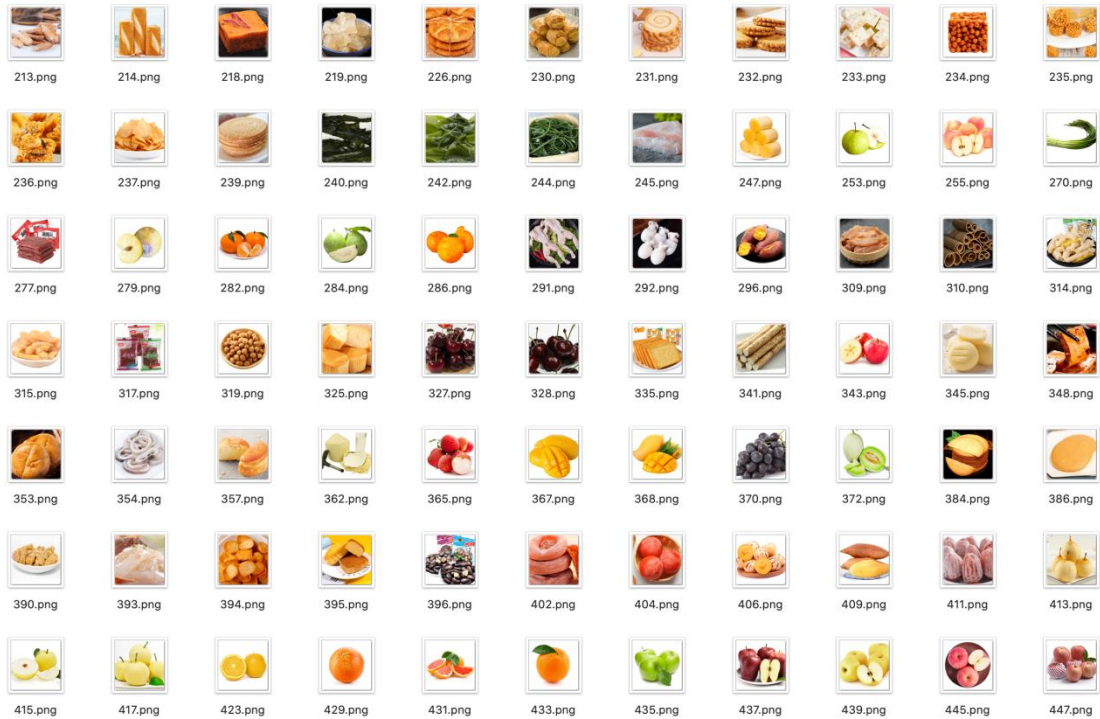

Department form:

DPTNO	NAME			
1	SHUIGUOBUMEN			
2	SHUCAIBUMEN			

Category table:

DEPTID	PLUNO			
1	2			
2	4			

2. Copy the compressed folder to a USB drive.
3. Plug in the USB. If the USB symbol on the main interface is , the identification is successful.
4. Click Menu to enter the background and select PLU List under the PLU option. Click Import to select the appropriate content to upload.

1.12 Initialize Date

Menu→Settings→Reset System→Select All

Global settings, shop name and text, department and main group, product, label format, place of origin, gategory, promotion data and logos can be optionally reset.

Click the  in the upper right corner to clear the content. Click OK to delete the content.

1.13 Customize the Assignment Key

The custom button is displayed in the upper right corner of the main window. Hold down the custom button and click to modify the button.

- Print packed on date opens to print date packaging.
- Print sell by date Change all packing dates after opening.
- After Disable printing tare is enabled, the label disables printing tare.
- After Enable \$100 is enabled, the amount over \$100 cannot be printed.
- Discount amount enter the amount to be exempted by the store.
- Discount % enter the percentage of the offer.
- Misc weight/misc non-weight/misc by count can be printed without calling up a PLU.
- Select label format is enabled to select different label formats.
- Speedkey allowcation becomes a shortcut key when enabled. Enter the speedkey allowcation operation directly.
- After Reprint opens, select PLU to print the previous transaction information.

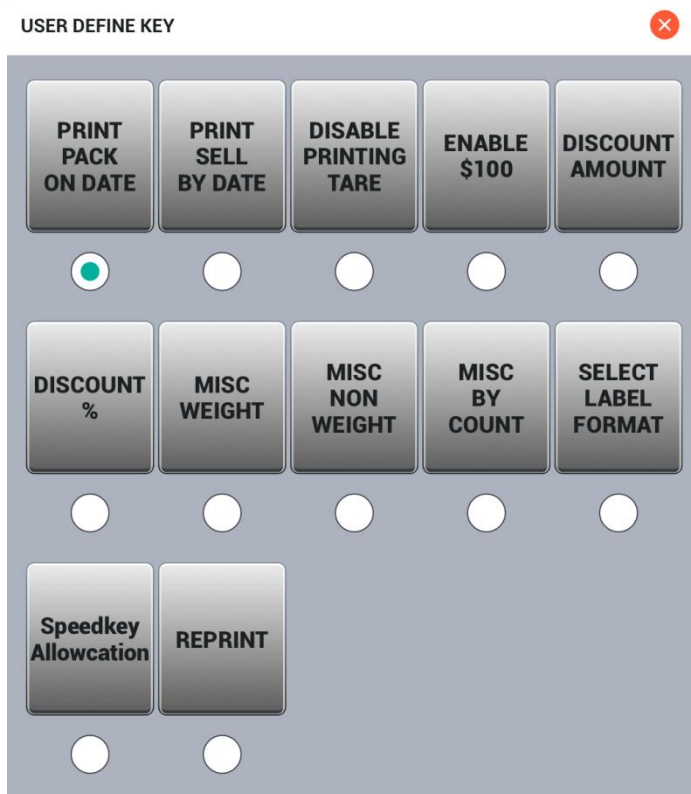

1.14 PLU Editor

Call up a PLU and click PLU Editor to quickly enter the product editing Basic information.

1.15 Language

Menu→Settings→Language

1.16 Set Date and Time

Menu→Settings→Set Date and Time

No.	Name	Project name	Description
1	Set Date and Time	Automatic date & time	
2		Automatic time zone	
3		Set date	
4		Set time	
5		Select time zone	
6		Use 24-hour format	

2. PROGRAMMING

2.1 PLU Programming

Project code+Menu	
PROJECT CODE	SUB MENU
1001	PLU List
1002	Shop Name
1003	Department Group
1004	Icon
1005	Promotion
1006	Speedkey Allowcation
1007	Place of Origin
2001	Global Settings
2002	Sale Configuration
2003	Calibration
2004	Internal Code
2005	Printer Setup
2006	Language
2007	Network Settings
2008	Reset System
2009	Set Date and Time
2010	Screen test

2.1.1 MODIFY THE LIST OF COMMODITY

2.1.1.1 Create By-Weight PLU

Menu→PLU→PLU List→ADD→PLU Type→By Weight

← Basic Ingredients / Special Information Extension

Department PLU Item Code PLU Type **By Weight**

Name 1 

Name 2 

Unit price Quantity Tare Sell by Date

Packed on Date





2.1.1.2 Create By NON-Weight PLU

Menu→PLU→PLU List→ADD→PLU Type→By non-Weight

← Basic Ingredients / Special Information Extension

Department PLU Item Code PLU Type **By Non Weight**

Name 1 

Name 2 

Unit price Quantity Tare Sell by Date

Packed on Date





2.1.1.3 Create By Count PLU

Menu→PLU→PLU List→ADD→PLU Type→By count

← Basic Ingredients / Special Information Extension

Department PLU Item Code PLU Type **By Count**

Name 1 

Name 2 

Unit price Quantity Tare Sell by Date

Packed on Date



2.1.1.4 PLU Settings

PLU can be used to edit, delete, copy, import, add, search, reset.



>

Department	PLU No.	Item Code	PLU Type	Name 1	Name 2	Unit Price
------------	---------	-----------	----------	--------	--------	------------

No.	Image	Name	Description
1		PLU Search	Quickly look up items by numbers or initials.
2		Reset	Reset the query content.
3		Commodity editor	Edit the selected item.
4		Product deletion	Deletes the selected item.
5		Copy PLU	Copy the selected item.
6		Import PLU	Import product information.
7		Create a new PLU	Create a new item.

No.	Name	Project name	Basic Information	Description
1	 Create a new PLU ADD	Basic	PLU NO.	0-999999
			Item Code	0-999999
			Department	0
			PLU Type	By weight By non-weight By count
			Item Name1	Enter the name of the item.
			Item Name 2	Enter the name of the item.
			Unit Price	Enter the unit price.
			Quantity	Quantity
			Tare	Commercial tare
			Sell by Date	0-365
		Packed on Date	0-365	
		Extension	Group no	Set master group
			Enable% Tare	Yes/No
			%Tare	0-99
			%Tare Limit	0-99
Print Sell by Date	Yes/No			
Print Packed on Date	Yes/No			

			Print Packed on Time	Yes/No
			Print Sell by Time	Yes/No
			Packed on Time	0-24
			Sell by Time	0-24
			Barcode 1 st two digit number	00
			Barcode Format	0:2D5I5PS 16:F1S 1:1D6I5PS 17:F1S 2:2D10IS 18:F1IS 3:2D5I5P5WS 19:F1S 4:2D5I5W5PS 20:F1S 5:1D6I5P5WS 21:2D4IXCD5P 6:1D6I5W5PS S 7:2D4I6PS 22:1D5IXCD5P 8:1D4I7PS S 9:1D5I6PS 23:2D5IXCD4P 10:2D4I5W6PS S 11:2D4I6P5WS 24:1D6IXCD4P 12:1D5I5W6PS S 13:1D5I6P5WS 25:1D5IXCD4P 14:NaN S 15:F1S 26:1D5IN4PS 27:1D5I5PS
			Label Format	1-45
			2nd Label Format	1-45
			Enable 2nd Label Format	Yes/No
			Barcode Type	0:X in the barcode is the weight 1:X in the barcode is the quantity 2:The X in the barcode is the total amount of the transaction
			Country of Origin	1-999999
		Ingredient List	Ingredients	
			Special Information	
	Edit a PLU			
	Delete a PLU			
	Copy a PLU			

2.2 PLU Date Table

Table

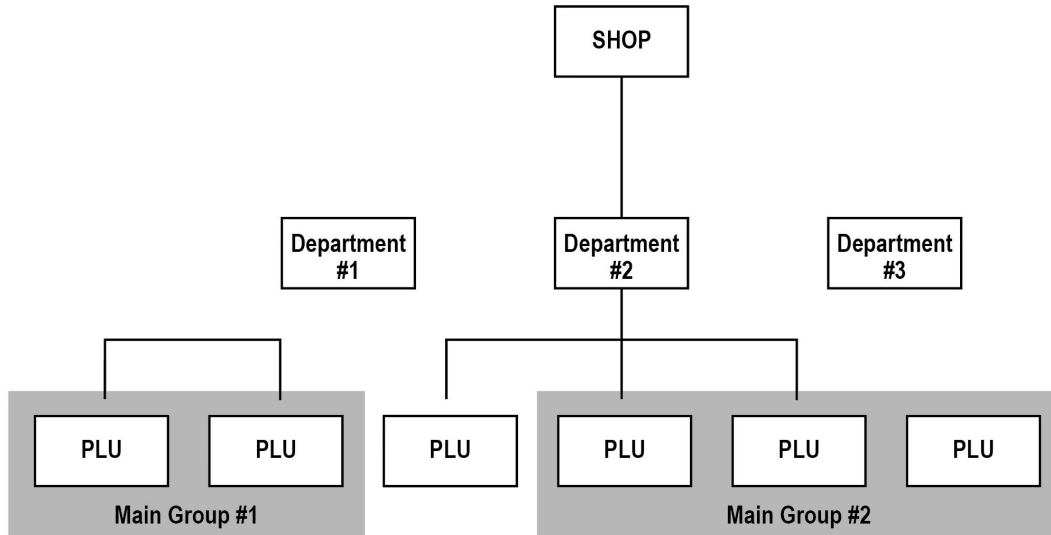

In the VLP-500 series, PLUs can be grouped into different groups, and different departments can include different PLUs.

Note: Product, picture, department and category information can be downloaded through DB-manager.

2.2.1 Shop Name

Shop Name can be set separately for the PLU.

Menu→PLU→Shop Name

No.	Name	Project name	Description
1	Shop Name	Shop Name	Edit department content
			Delete department content

Edit a shop name

No.	Name	Project name	Basic Information	Description
1	Edit a shop name	Number		
2		Content		
3		Font Size	G1-G7	

Delete a shop name

No.	Name	Project name	Basic Information	Description
1	Delete a shop name	Are you sure to delete this ShopName?	Yes/No	

2.2.2 Department

Department can be set separately for the PLU.

Menu→PLU→Department Group→Department

No.	Name	Project name	Description
1	Department Group	Department	Add department content
			Edit department content
			Delete department content

2.2.3 Main Group

Main Group can be set separately for the PLU.

Menu→PLU→Department Group→Main Group

No.	Name	Project name	Description
1	Department Group	Main group	Add main group content
			Edit main group content
			Delete main group content

2.2.4 Place of Origin

Place of Origin can be set separately for the PLU.

Menu→PLU→Place of Origin

No.	Name	Project name	Description
1	Place of Origin	Add a origin	code
			content

2.3 Discount

No.	Name	Project name	Basic Information	Description
1	Promotion	Discount amount(\$)	PLU No.	
			Promotion Price	
			Begin Date	
			End Date	
			Begin Time	
			End Time	
2		Discount(%)	PLU No.	
			Promotion Price	
			Begin Date	
			End Date	
			Begin Time	
			End Time	

2.4 Global Discount Programming

Menu→PLU→PLU List→Promotion

No.	Name	Project name	Basic Information	Description
1	Discount amount(\$)	PLUNO		
2		Promotion price		
3		Begin date		
4		End date		
5		Begin time		
6		End time		

No.	Name	Project name	Basic Information	Description
1	Discount(%)	PLUNO		
2		Discount(%)		
3		Begin date		
4		End date		
5		Begin time		
6		End time		

2.5 Speedkey Setting

Menu→PLU→Speedkey Allowcation

No.	Name	Project name	Description
1	Speedkey allowcation	Auto	Automatically allocate PLU list contents
2		DEL	Delete a PLU shortcut key
3		SAVE	Save the modified shortcut key
4		Layer 1 / Layer 2 / Layer 3	The first layer 1-56 shortcut key, the second layer 57-112 shortcut key, the third layer 113-168 shortcut key
5		Deallocate	The content of the shortcut keys is returned to the list for modification
6		Allocate	The created PLU is placed in the left shortcut key
7		Search	Search a PLU
8		Reset	The content of the Plu list was reset
9		More	View and edit more PLU content

← SPEEDKEY

PLU List NO SCROLLING PLU NAME.

PLU No	PLU Name	Layer 1	Layer 2	Layer 3
101101	Chile imported apples <input type="button" value="MORE"/>	1 Apple	2 Apple	3 PLU Name
101101	Chile imported apples <input type="button" value="MORE"/>	4 PLU Name	5 PLU Name	6 PLU Name
101101	Chile imported apples <input type="button" value="MORE"/>	7 PLU Name	8 PLU Name	9 PLU Name
101101	Chile imported apples <input type="button" value="MORE"/>	10 PLU Name	11 PLU Name	12 PLU Name
101101	Chile imported apples <input type="button" value="MORE"/>	13 PLU Name	14 PLU Name	15 PLU Name
101101	Chile imported apples <input type="button" value="MORE"/>	16 PLU Name	17 PLU Name	18 PLU Name
101101	Chile imported apples <input type="button" value="MORE"/>	19 PLU Name	20 PLU Name	21 PLU Name
101101	Chile imported apples <input type="button" value="MORE"/>	22 PLU Name	23 PLU Name	24 PLU Name
101101	Chile imported apples <input type="button" value="MORE"/>	25 PLU Name	26 PLU Name	27 PLU Name
101101	Chile imported apples <input type="button" value="MORE"/>	28 PLU Name	29 PLU Name	30 PLU Name
101101	Chile imported apples <input type="button" value="MORE"/>	31 PLU Name	32 PLU Name	33 PLU Name
101101	Chile imported apples <input type="button" value="MORE"/>	34 PLU Name	35 PLU Name	36 PLU Name
101101	Chile imported apples <input type="button" value="MORE"/>	37 PLU Name	38 PLU Name	39 PLU Name
101101	Chile imported apples <input type="button" value="MORE"/>	40 PLU Name	41 PLU Name	42 PLU Name
101101	Chile imported apples <input type="button" value="MORE"/>	43 PLU Name	44 PLU Name	45 PLU Name
101101	Chile imported apples <input type="button" value="MORE"/>	46 PLU Name	47 PLU Name	48 PLU Name
101101	Chile imported apples <input type="button" value="MORE"/>	49 PLU Name	50 PLU Name	51 PLU Name
101101	Chile imported apples <input type="button" value="MORE"/>	52 PLU Name	53 PLU Name	54 PLU Name
101101	Chile imported apples <input type="button" value="MORE"/>	55 PLU Name	56 PLU Name	56 PLU Name

← 1/21 →

Press and hold the shortcut key to change the color.

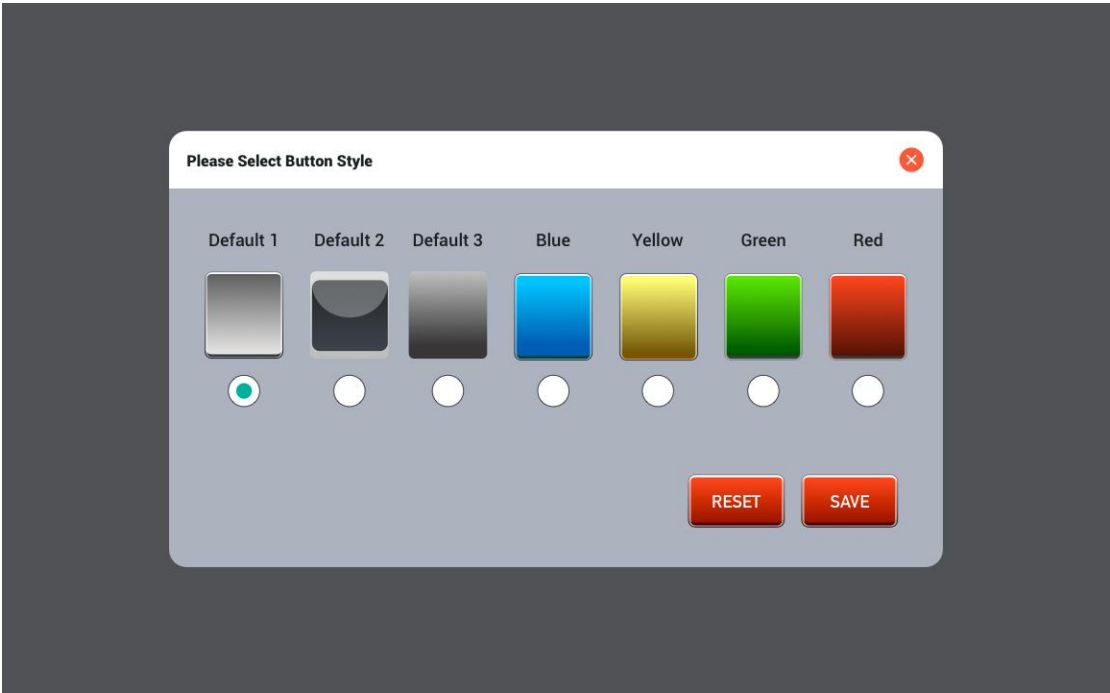

No walking PLU name Check the front to turn on the running light.

2.6 County Programming

Menu→PLU→PLU List→Add→Extension

Enter the password: 0.

PASSWORD



Input field for password:

7	8	9	
4	5	6	ENTER
1	2	3	
C	0	00	

Navigation: Basic **Ingredients / Special Information** **Extension**

Group no.	<input type="text"/>	Enable%Tare <input checked="" type="checkbox"/>	%Tare <input type="text"/>	%Tare Limit <input type="text"/>			
Print Sell by Date	<input checked="" type="checkbox"/>	Print Packed on Date	<input checked="" type="checkbox"/>	Print Packed on Time	<input checked="" type="checkbox"/>	Print Sell by Time	<input type="checkbox"/> OFF
Packed on Time	<input type="text"/>	Sell by Time	<input type="text"/>	Barcode 1st two digits number	<input type="text"/>	Barcode Format	<input type="text"/>
Lable Format	<input type="text"/>	Enable 2nd Label Format	<input type="checkbox"/> OFF	2nd Label Format	<input type="text"/>	Barcode Type	<input type="text"/>
Country of origin	<input type="text" value="95001"/>						

WARNING:

1. When you switch off %Tare, any value in %Tare and Tare Limit will not be treated.
2. 2nd Label format is not normal function. it is used for only printing TWO different labels for a PLU.

2.7 Global Setting

No.	Name	Number	Basic Information	Description	Default	
1	Global Settings	1	To use SPEC2-SPEC4 to override the PLU properties	0:On 1:Off	On	
2		2	Default fist two digit numbers of barcode for By weight plu (1-99)	1-99	2	
3		3	Default fist two digit numbers of barcode for By Non- weight plu (1-99)	1-99	2	
4		4	Default fist two digit numbers of barcode for By Count plu (1-99)	1-99	2	
5		5	Barcode format for weighing plu	0:2D5I5PS 1:1D6I5PS 2:2D10IS 3:2D5I5P5WS 4:2D5I5W5PS 5:1D6I5P5WS 6:1D6I5W5PS 7:2D4I6PS 8:1D4I7PS 9:1D5I6PS 10:2D4I5W6PS 11:2D4I6P5WS 12:1D5I5W6PS 13:1D5I6P5WS 14:NaN 15:F1S	16:F1S 17:F1S 18:F1S 19:F1S 20:F1S 21:2D4IXCD5PS 22:1D5IXCD5PS 23:2D5IXCD4PS 24:1D6IXCD4PS 25:1D5IXCD4PS 26:1D5IN4PS 27:1D5I5PS	23
6		6	Barcode format for non-weighing plu	0:2D5I5PS 1:1D6I5PS 2:2D10IS 3:2D5I5P5WS 4:2D5I5W5PS 5:1D6I5P5WS	16:F1S 17:F1S 18:F1S 19:F1S 20:F1S 21:2D4IXCD5PS	23

				6:1D6I5W5PS 7:2D4I6PS 8:1D4I7PS 9:1D5I6PS 10:2D4I5W6PS 11:2D4I6P5WS 12:1D5I5W6PS 13:1D5I6P5WS 14:NaN 15:F1S	22:1D5IXCD5PS 23:2D5IXCD4PS 24:1D6IXCD4PS 25:1D5IXCD4PS 26:1D5IN4PS 27:1D5I5PS	
7	7	Barcode format for bycount plu	0:2D5I5PS 1:1D6I5PS 2:2D10IS 3:2D5I5P5WS 4:2D5I5W5PS 5:1D6I5P5WS 6:1D6I5W5PS 7:2D4I6PS 8:1D4I7PS 9:1D5I6PS 10:2D4I5W6PS 11:2D4I6P5WS 12:1D5I5W6PS 13:1D5I6P5WS 14:NaN 15:F1S	16:F1S 17:F1S 18:F1S 19:F1S 20:F1S 21:2D4IXCD5PS 22:1D5IXCD5PS 23:2D5IXCD4PS 24:1D6IXCD4PS 25:1D5IXCD4PS 26:1D5IN4PS 27:1D5I5PS	23	
8	8	Enable Global barcode format, refer to SPEC5 SPEC6,SPEC7I	0:On 1:Off			
9	9	Enable Global barcode format, refer to SPEC14 SPEC15	0:On 1:Off			
10	11	Default label format for MISC byWT 0-99		0-99	5	
11	12	Default label format for MISC NONWT 0-99	0-99		5	
12	13	Default label format for MISC BYCOUNT 0-99	0-99		5	
13	14	Default label format	0-99		5	

			0-99		
14		15	Default label format for No2 label 0-99	0-99	0
15		17	Default PLU Name font	0:BY PLU 1:G1 5:G5 2:G2 6:G6 3:G3 7:G7 4:G4	Following Commodity Attributes
16		18	Default ingredient font	0:BY PLU 1:G1 5:G5 2:G2 6:G6 3:G3 7:G7 4:G4	Following Commodity Attributes
17		19	Default special information font	0:BY PLU 1:G1 5:G5 2:G2 6:G6 3:G3 7:G7 4:G4	Following Commodity Attributes
18		20	PLUNO formatted length	0-6	6
19		22	Default font for MISC PLU Name	1:G1 5:G5 2:G2 6:G6 3:G3 7:G7	G4
20		24	Delay for cash box open	0:Hardware Decided 1:40ms 6:240ms 2:80ms 7:280ms 3:120ms 8:320ms 4:160ms 9:360ms 5:200ms	Hardware Decided
21		25	Print PCS for weighing PLU	0:On 1:Off	On
22		26	Print weight for non-weighing PLU	0:On 1:Off	Off
23		27	Enable print without PLU	0:On 1:Off	On
24		28	Support manual print without weight change	0:On 1:Off	On
25		33	Allow the check for missing paper or not	0:On 1:Off	On
26		40	Maximum discount	1~100	1

			amount		
27	41	Maximum discount rate			50
28	43	Allow all items to be promoted	0:On 1:Off		On
29	44	Allow cash discounts on all items	0:On 1:Off		On
30	45	Allow percentage discounts on all items	0:On 1:Off		On
31	46	Do not print labels when the barcode is invalid	0:On 1:Off		On
32	49	Default shop name id	1 ~ 32		1
33	53	Print after removing label	0:On 1:Off		On
34	54	Record transactions or not when printing labels	0:On 1:Off		Off
35	66	Allow automatic printing when select PLU	0:On 1:Off		Off
36	140	Barcode encoding formats	0:EAN8/13 1:EAN128 6:120F5 2:CODE128 7:UPC13 3:UPCA 8:CODE39 4:UPCE 9:CODE93 5:EAN13A5 10:CODABAR		0
37	180	Print weight unit information	0:On 1:Off		Off
38	185	Print Money Symbol	0:On 1:Off		On
39	186	Print Money Unit	0:On 1:Off		Off
40	187	Print Package on Date	0:On 1:Off		On
41	188	Print Sale by Date	0:On 1:Off		On
42	189	Enable Global Print DATE, please refer to SPEC187, SPEC188	0:On 1:Off		
43	220	use EAN barcode counter-check or not	0:On 1:Off		Off
44	503	No process tail number of	0:On 1:Off		On

		Non-weight PLU		
45	505	Carry the total price from 1/10 cent to cent	0:Rounding Up 1:Rounding Tail 2:Add Tail	Rounding Up
46	506	Carry the total price from \$0.01to\$0.1	0:No processing 1:Rounding Up 2:Rounding Tail 3:Add Tail	No processing
47	512	Minimum weight value to print		5
48	533	Protection Password t (0 for no password)	0:no password	0
49	535	Allow to change default label formats	0:On 1:Off	Off
50	536	Open cashbox when print label	0:On 1:Off	Off
51	607	Number of plus displayed per page	1-30	
52	621	Use the system buzzer	0:On 1:Off	On
53	631	Enable SYSTEM Log	0:On 1:Off	
54	635	Number of items displayed per page in Search View	1-18	
55	636	Enable Password Protection	0:On 1:Off	
56	637	Enable Password Protection for Override	0:On 1:Off	
57	638	Enable Password Protection for TOOL	0:On 1:Off	
58	639	Enable Password Protection for MENU	0:On 1:Off	
59	640	Enable Password Protection for PLU Editor	0:On 1:Off	
60	641	Side screen size	100 10inches side screen 101 7inches side screen	
61	643	Enable Password Protection for PLU Editor Extension	0:On 1:Off	

2.8 Printing Programming

Menu→Settings→Printer Setup

The printer can set the printing concentration, starting position, reverse printing, continuous printing, etc.

No.	Name	Project name	Description
1	Printer Setup	Position sensor value	0
2		Remove sensor value	60
3		Print head starts at(mm)	8.0
4		Support reverse printing	On/Off
5		Set print head density	1-6
6		Support continuous printing	On/Off

Step 1

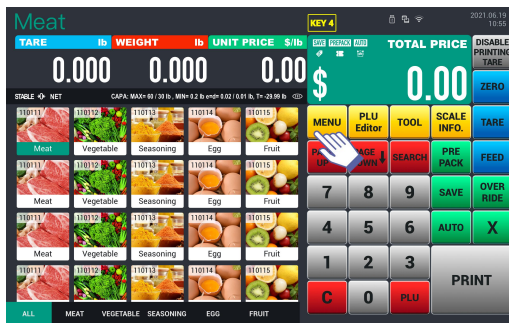

Step 2



Step 3



Step 4

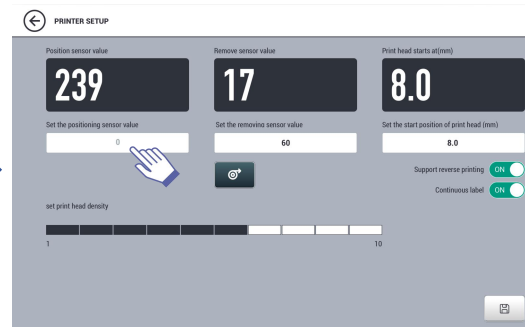

Step 5

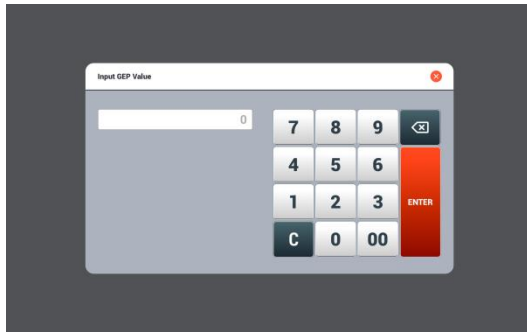

Step 6

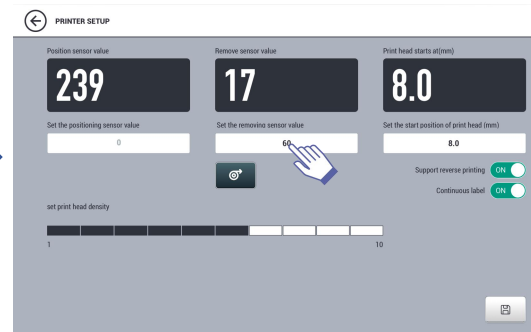

Step 7

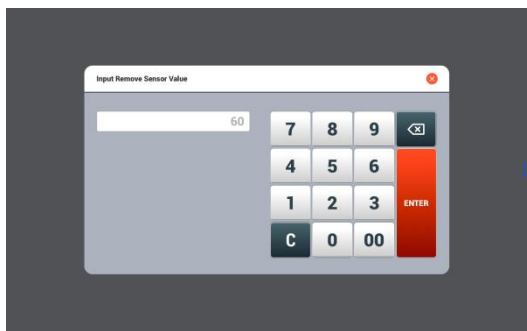

Step 8

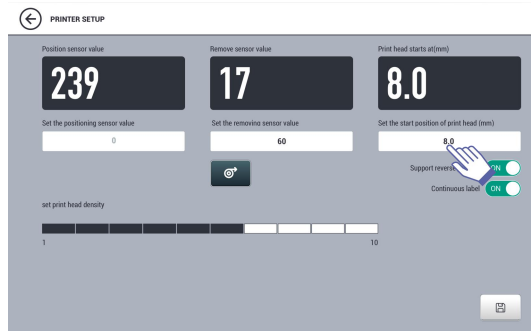

Step 9

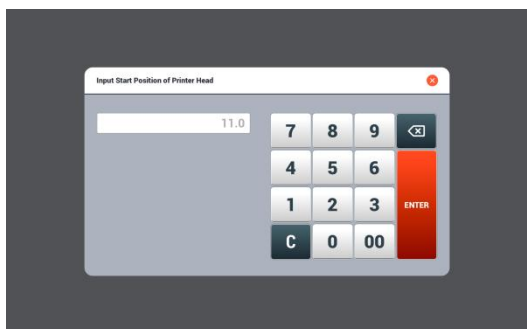

Step 10



Press Save after setting.

2.9 Scale Configuration

Click on "SCALE INFO." to view basic information.

For example:

TYPE	VALUE
PLU	1
Scale	1
Department	N/A
IP	0.0.0.0
SSID	Unknown ssid
DATE TIME	Date and time of the day

2.10 Network Configuration

Menu→Settings→Network Settings

No.	Name	Project name	Description
1	Network Settings	Wi-Fi	On/Off
2		Mobile network	
3		Date usage	
4		Hotspot & tethering	
5		VPN	
6		Mobile plan	
7		Ethernet	Wired network
8		Airplane mode	On/Off

2.11 Using the Icon

Menu→PLU→Icon

No.	Name	Project name	Description
1	Icon	No.	Number
2		Preview	Preview icon
3		Delete Icon	Yes/No

2.12 About

Menu→About

🏠 Home page	SHANGHAI DIGITAL BALANCE ELECTRONIC CO., LTD			
Calibration	CPU	rk3288		
	RAM	2.00G	Internal Storage	8G
Internal Code	Screen Size	10.1 Inches	Screen Resolution	1280•800
Printer Setup	Android Version	8.1.0		
	Kernel Version	4.4.132		
Language	Application Version	US_3.0.0.43.14		
Network Settings	Extension Board Version(A/D)	Ur-5.01		
Reset System	Printer Version Number	TMP558Ur5800		
Set Date and Time	Commodity File	0	Tax Rate File	3
	Promotion Record	0	Label Format File	45
Screen Test	Shop Name File	0	User-defined Format File	45
📄 About	File of Place of Origin	0	Picture File	45

3. SALES OPERATION

3.1 Basic Operation

Step 1

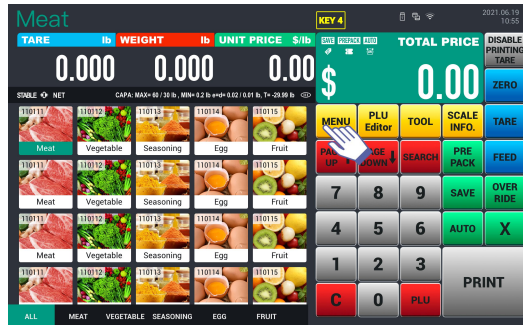

Step 2

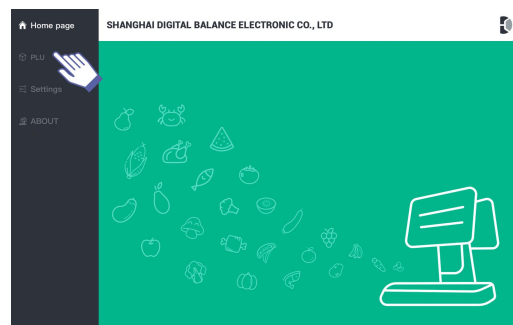

Step 3



Step 4

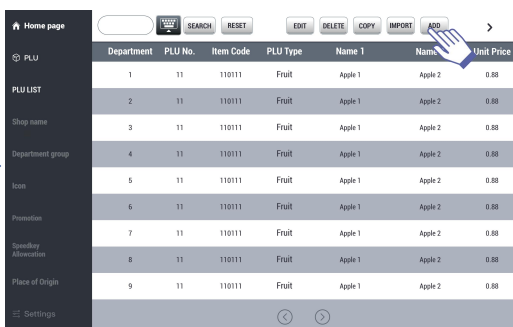

Step 5

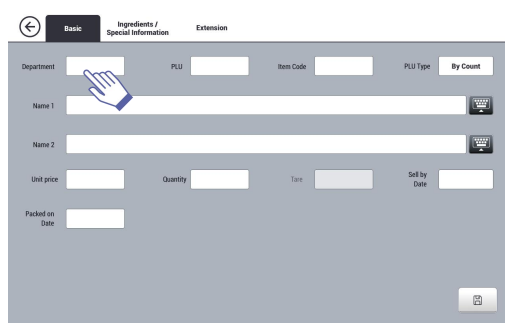

Step 6

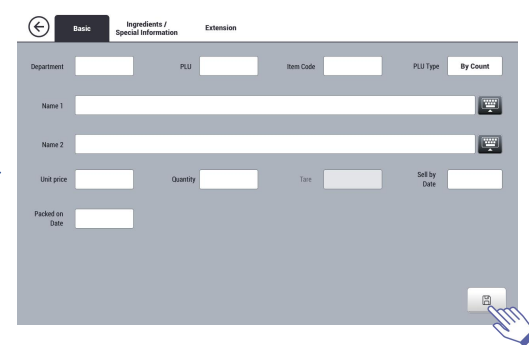

Click the blank box to enter the value.

Step 7

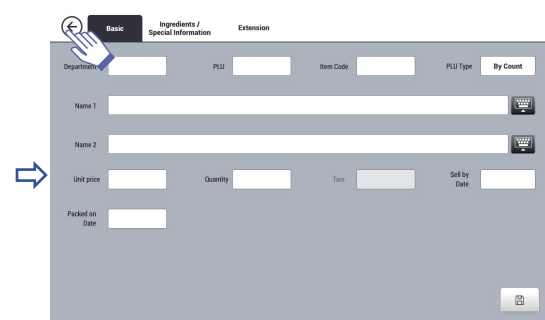

Please press the save button after typing.

3.2 Zero

*The initial zero point range of zero before the scale is turned on is 10%FS

*During the use of the scale body, the zero setting range is 4% FS

Click the zero button to zero.

Key 4 Mode

The screenshot displays a POS scale interface in 'Key 4 Mode'. The top status bar shows the date and time as 2021.06.19 10:55. The main display area is divided into sections for TARE, WEIGHT, UNIT PRICE, and TOTAL PRICE, all showing 0.00. A 'ZERO' button is highlighted with a hand cursor. The interface includes a grid of product categories (Meat, Vegetable, Seasoning, Egg, Fruit) and a numeric keypad with function buttons like MENU, PLU Editor, TOOL, SCALE INFO., TARE, FEED, SAVE, OVER RIDE, AUTO, X, PRINT, and C.

3.3 Tare

*Peeling range is less than 50% FS

Step 1 Place a container and remove the skin.

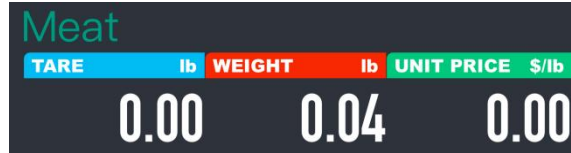

Step 2 Click Tare to start peeling.



Step 3 After removing tare weight.



Step 4 Click Tare again to cancel the peel.

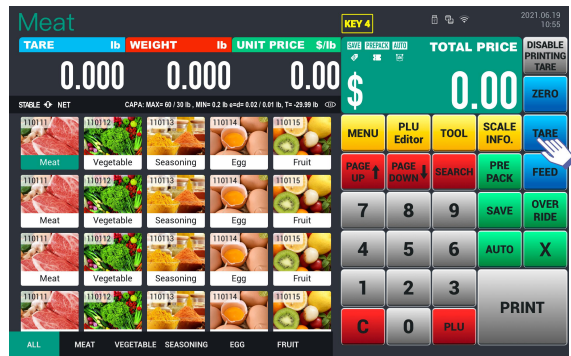

Preset TARE

Menu→PLU→PLU List→Choose a PLU→Edit→Basic→By Weight→Tare

3.4 Calling Up a PLU

Here are 6 ways to call up a PLU in different KEY modes.

Method 1: Enter the value and click PLU to call up.

Method 2

Key 1 Mode

Click the shortcut key  on the left, the preset product information appears.

Method 3

Key 2 Mode

Click the shortcut key  on the left, the preset product information appears.

Method 4

Key 3

Click the shortcut key  on the left, the preset product information appears.

Method 5

Key 4

Click the shortcut key  on the left, the preset product information appears.

Method 6

Key 5

Click the shortcut key  on the left, the preset product information appears.

3.5 Override

Override is used to change prices. There are different options for weight, no weight, piece items. PLU type depends on the selection of the "Basic" attribute when adding an item.

3.5.1 By-Weight PLU

Call up a weight PLU and click Override to change pricing and other Settings.

Project Name	Description
Name	
PLU No.	
Total Purchased QTY	Weighing items cannot be changed.
Unit Pieces	Weighing items cannot be changed.
Unit Price(\$)	
SAVE Unit Price	
SAVE U.P.& PRINT	
TARE	
ZERO	
C	
PRINT without Saving Unit Price	

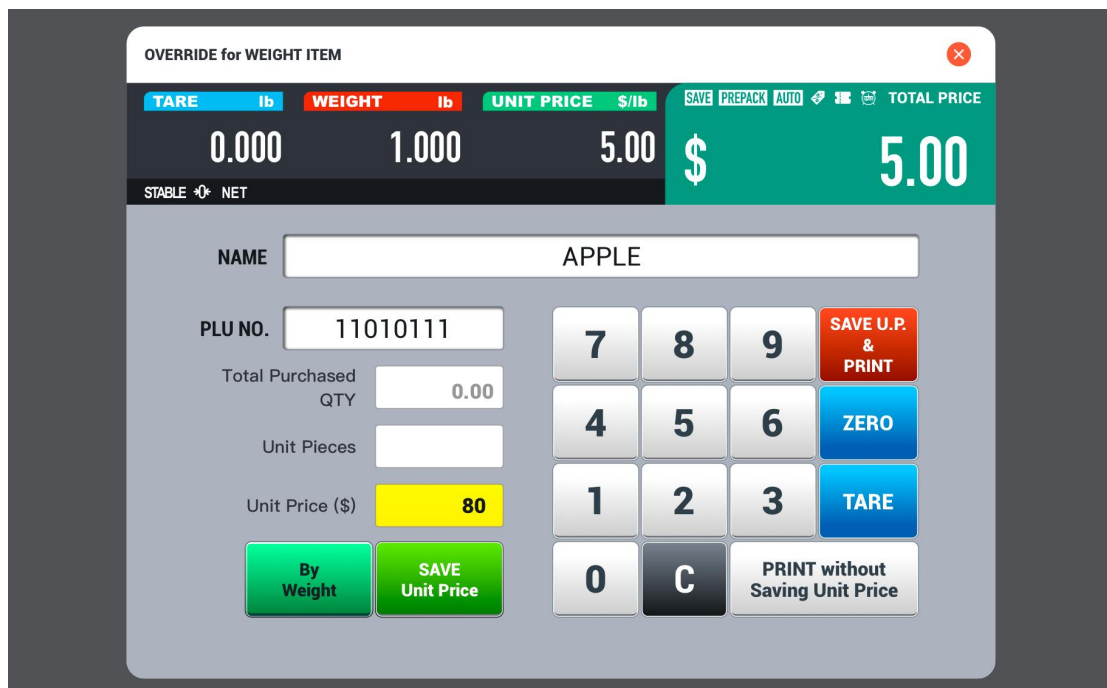

Press By Weight to switch to By Count.

OVERRIDE for By COUNT ITEM ✕

TARE	lb	WEIGHT	lb	UNIT PRICE	\$/lb	SAVE	PREPACK	AUTO	TOTAL PRICE
PCS		1-1		5.00		\$			5.00
STABLE NET									

NAME

PLU NO.

Total Purchased QTY

Unit Pieces

Unit Price (\$)

By Count

SAVE Unit Price

7	8	9	SAVE U.P. & PRINT
4	5	6	ZERO
1	2	3	TARE
0	C	PRINT without Saving Unit Price	

3.5.2 By Non-Weight PLU

Call up a non-weight PLU and click Override to change pricing and other Settings.

Project Name	Description
Name	
PLU No.	
Total Purchased QTY	
Unit Pieces	
Unit Price(\$)	The unit price of goods without weight cannot be changed.
SAVE Unit Price	
Print with weight	After checking, you can put the weight and print it on the label paper.
SAVE U.P.& PRINT	
TARE	
ZERO	
C	
PRINT without Saving Unit Price	

OVERWRITE for NON-WEIGHT ITEM
✕

TARE lb
WEIGHT lb
UNIT PRICE \$/lb

SAVE PREPACK AUTO 🔊 📄 TOTAL PRICE

PCS
1
5.00
\$
5.00

STABLE ⊖ NET

NAME

PLU NO.

Total Purchased QTY

Unit Pieces

Unit Price (\$) 80

SAVE Unit Price

7
8
9
SAVE U.P. & PRINT

4
5
6
ZERO

1
2
3
TARE

0
C
PRINT without Saving Unit Price

3.5.3 By Count PLU

Call up a count PLU and click Override to change pricing and other Settings.

Project Name	Description
Name	
PLU No.	
Total Purchased QTY	Total number of copies.
Unit Pieces	Break it into pieces.
Unit Price(\$)	
SAVE Unit Price	
Print with weight	After checking, you can put the weight and print it on the label paper.
SAVE U.P.& PRINT	
TARE	
ZERO	
C	
PRINT without Saving Unit Price	

OVERWRITE for By COUNT ITEM
✕

TARE

lb

WEIGHT

lb

UNIT PRICE

\$/lb

SAVE

PREPACK

AUTO

🔍 🗨️ 📄

TOTAL PRICE

PCS

1-1

5.00

\$

5.00

STABLE
NET

NAME

PLU NO.

Total Purchased QTY

Unit Pieces

Unit Price (\$) 80

SAVE Unit Price

7	8	9	SAVE U.P. & PRINT
4	5	6	ZERO
1	2	3	TARE
0	C	PRINT without Saving Unit Price	