



Test report No. : 4790358903-US-R1-V0
Page : 1 of 154
Issued date : 2022/6/7
FCC ID : 2A4GY-LB-TABLET01

RADIO TEST REPORT

Product : LITEBOXER TABLET
Model Name : LB-TABLET01
FCC ID : 2A4GY-LB-TABLET01
Test Regulation : FCC 47 CFR Part 15 Subpart E (Section 15.407)
Received Date : 2022/4/13
Test Date : 2022/4/14 ~ 2022/4/22
Issued Date : 2022/6/7

Applicant : Liteboxer Technologies, Inc
52R Roland St, Boston, MA 02129, USA

Issued By : Underwriters Laboratories Taiwan Co., Ltd.
Building B and Building E, No. 372-7, Sec. 4, Zhongxing Rd.,
Zhudong Township, Hsinchu County, Taiwan



The results reported herein have been performed in accordance with the laboratory's terms of accreditation. This report shall not be reproduced except in full without the written approval of the Laboratory. The results in this report are responsible of the test sample(s) provided by the client only and are not to be used to indicate applicability to other similar products.

Underwriters Laboratories Taiwan Co., Ltd.

Building B and Building E, No. 372-7, Sec. 4, Zhongxing Rd., Zhudong Township, Hsinchu County, Taiwan
Telephone :+886-2-7737-3000
Facsimile (FAX) :+886-3-583-7948

Doc No: 17-EM-F0878 / 6.0



Table of Contents

1. Attestation of Test Results	4
2. Summary of Test Results	5
3. Test Methodology and Reference Procedures.....	6
4. Facilities and Accreditation	6
5. Measurement Uncertainty	7
6. Equipment under Test	8
6.1. Description of EUT	8
6.2. Channel List	10
6.3. Test Condition.....	12
6.4. Description of Available Antennas	12
6.5. Test Mode Applicability and Tested Channel Detail.....	13
6.6. Duty cycle	15
7. Test Equipment.....	16
8. Description of Test Setup.....	18
9. Test Results.....	20
9.1. 6dB Bandwidth	20
9.2. 26dB Bandwidth	27
9.3. Occupied Bandwidth.....	43
9.4. Conducted output power	61
9.5. Power Spectral Density.....	67
9.6. Frequency Stability	85
9.7. Radiated Spurious Emission	87
9.8. AC Power Line Conducted Emission	151

Underwriters Laboratories Taiwan Co., Ltd.

Building B and Building E, No. 372-7, Sec. 4, Zhongxing Rd., Zhudong Township, Hsinchu County, Taiwan

Telephone :+886-2-7737-3000

Facsimile (FAX) :+886-3-583-7948

Doc No: 17-EM-F0878 / 6.0



1. Attestation of Test Results

APPLICANT: Liteboxer Technologies, Inc
 52R Roland St, Boston, MA 02129, USA

MANUFACTURER: InnoComm Mobile Technology Corporation
 3F, No. 6, Hsin Ann Rd., Hsinchu Science Park, Hsinchu 300092,
 Taiwan

EUT DESCRIPTION: LITEBOXER TABLET

BRAND: LITEBOXER

MODEL: LB-TABLET01

SAMPLE STAGE: Design Verification Test sample

DATE of TESTED: 2022/4/14 ~ 2022/4/22

APPLICABLE STANDARDS	
STANDARD	Test Results
FCC 47 CFR PART 15 Subpart E (Section 15.407)	PASS

Underwriters Laboratories Taiwan Co., Ltd. tested the above equipment in accordance with the requirements set forth in the above standards. All indications of Pass/Fail in this report are opinions expressed by Underwriters Laboratories Taiwan Co., Ltd. based on interpretations and/or observations of test results. The test results show that the equipment tested is capable of demonstrating compliance with the requirements as documented in this report.

Note: The results documented in this report apply only to the tested sample, under the conditions and modes of operation as described herein. This document may not be altered or revised in any way unless done so by Underwriters Laboratories Taiwan Co., Ltd. and all revisions are duly noted in the revisions section. Any alteration of this document not carried out by Underwriters Laboratories Taiwan Co., Ltd. will constitute fraud and shall nullify the document. This report must not be used by the client to claim product certification, approval, or endorsement by NVLAP, NIST, any agency of the Federal Government, or any agency of any government.

Prepared By:

Sally Lu Date : 2022/6/7
 Project Handler

Approved and Authorized By:

Eric Lee Date : 2022/6/7
 Senior Laboratory Engineer

Underwriters Laboratories Taiwan Co., Ltd.

Building B and Building E, No. 372-7, Sec. 4, Zhongxing Rd., Zhudong Township, Hsinchu County, Taiwan
 Telephone :+886-2-7737-3000
 Facsimile (FAX) :+886-3-583-7948



2. Summary of Test Results

Summary of Test Results		
FCC Clause	Test Items	Result
15.407(e)	6dB Bandwidth	PASS
15.403(i)	26dB Bandwidth	PASS
2.1049	Occupied Bandwidth	See Note1
15.407(a)(1/2/3)	Conducted Output Power	PASS
15.407(a)(1/2/3)	Power Spectral Density	PASS
15.407(g)	Frequency Stability	PASS
15.407(b) (1/2/3/4(i/ii)/9)	Radiated Emissions and Band Edge Measurement	PASS
15.407(b)(9)	AC Power Conducted Emission	PASS
15.203	Antenna Requirement	PASS
15.407(h)	Dynamic Frequency Selection	See Note2

Note:

1. The Occupied Bandwidth was reference only.
2. The “Dynamic Frequency Selection measurement” was recorded in Report No.: 4790358903-US-R2-V0

Underwriters Laboratories Taiwan Co., Ltd.

Building B and Building E, No. 372-7, Sec. 4, Zhongxing Rd., Zhudong Township, Hsinchu County, Taiwan

Telephone :+886-2-7737-3000

Facsimile (FAX) :+886-3-583-7948

Doc No: 17-EM-F0878 / 6.0



3. Test Methodology and Reference Procedures

The tests documented in this report were performed in accordance with 47 CFR FCC Part 2, KDB 789033 D02 General UNII Test Procedure New Rules v02r01, KDB414788 D01 Radiated Test Site v01r01, ANSI C63.10-2013 and KDB 662911 D01 Multiple Transmitter Output v02r01.

4. Facilities and Accreditation

Test Location	Underwriters Laboratories Taiwan Co., Ltd.
Address	Building B and Building E, No. 372-7, Sec. 4, Zhongxing Rd., Zhudong Township, Hsinchu County, Taiwan
Accreditation Certificate	Underwriters Laboratories Taiwan Co., Ltd. is accredited by TAF, Laboratory Code 3398.

Underwriters Laboratories Taiwan Co., Ltd.

Building B and Building E, No. 372-7, Sec. 4, Zhongxing Rd., Zhudong Township, Hsinchu County, Taiwan

Telephone :+886-2-7737-3000

Facsimile (FAX) :+886-3-583-7948



5. Measurement Uncertainty

For statement of conformity, accuracy method (Section 8.2.4 and 8.2.5 of ISO Guide 98-4) was applied as decision rule for measurement in this test report.

The following uncertainties have been calculated to provide a confidence level of 95 % using a coverage factor $k=2$.

Measurement	Frequency	Uncertainty
Conducted disturbance at mains terminals ports	150kHz ~ 30MHz	± 2.9 dB
RF Conducted	9 kHz - 40GHz	± 2.4 dB
Radiated disturbance below 30MHz	9 kHz - 30 MHz	± 1.9 dB
Radiated disturbance below 1 GHz	30MHz ~ 1GHz	± 5.8 dB
Radiated disturbance above 1 GHz	1GHz ~ 40GHz	± 4.8 dB

Underwriters Laboratories Taiwan Co., Ltd.

Building B and Building E, No. 372-7, Sec. 4, Zhongxing Rd., Zhudong Township, Hsinchu County, Taiwan

Telephone :+886-2-7737-3000

Facsimile (FAX) :+886-3-583-7948

Doc No: 17-EM-F0878 / 6.0



6. Equipment under Test

6.1. Description of EUT

Product	LITEBOXER TABLET	
Brand Name	LITEBOXER	
Model Name	LB-TABLET01	
Operating Frequency	5180 ~ 5240 MHz, 5260 ~ 5320 MHz, 5500 ~ 5700 MHz, 5745 ~ 5825 MHz	
Modulation	256QAM, 64QAM, 16QAM, QPSK, BPSK	
Transfer Rate	802.11a: up to 54 Mbps 802.11n: up to MCS15 802.11ac: up to MCS9	
Number of Channel	5180 ~ 5240 MHz	4 for 802.11a, 802.11n (HT20), 802.11ac (VHT20)
		2 for 802.11n (HT40), 802.11ac (VHT40)
		1 for 802.11ac (VHT80)
	5260 ~ 5320 MHz	4 for 802.11a, 802.11n (HT20), 802.11ac (VHT20)
		2 for 802.11n (HT40), 802.11ac (VHT40)
		1 for 802.11ac (VHT80)
	5500 ~ 5700 MHz	11 for 802.11a, 802.11n (HT20), 802.11ac (VHT20)
		5 for 802.11n (HT40), 802.11ac (VHT40)
		2 for 802.11ac (VHT80)
	5745 ~ 5825 MHz	5 for 802.11a, 802.11n (HT20), 802.11ac (VHT20)
		2 for 802.11n (HT40), 802.11ac (VHT40)
		1 for 802.11ac (VHT80)
Maximum Output Power	5180 ~ 5240 MHz: 19.37 dBm 5260 ~ 5320 MHz: 19.44 dBm 5500 ~ 5700 MHz: 19.33 dBm 5745 ~ 5825 MHz: 19.45 dBm	
Normal Voltage	120Vac/ 60Hz	
S/N	VLB10B2329100044	
Sample ID	Conducted Test: 4848505 Radiated Test: 4848508	
Software Version	Android version 11	

Underwriters Laboratories Taiwan Co., Ltd.

Building B and Building E, No. 372-7, Sec. 4, Zhongxing Rd., Zhudong Township, Hsinchu County, Taiwan
Telephone :+886-2-7737-3000
Facsimile (FAX) :+886-3-583-7948



Note:

1. The EUT incorporates a MIMO function. Physically, the EUT provides two completed transmitters and two receivers.

Modulation Mode	Tx,Rx Function
802.11a	2TX,2RX
802.11n (HT20)	2TX,2RX
802.11n (HT40)	2TX,2RX
802.11ac (VHT20)	2TX,2RX
802.11ac (VHT40)	2TX,2RX
802.11ac (VHT80)	2TX,2RX

* The modulation and bandwidth are similar for 802.11n mode for HT20 / HT40 and 802.11ac mode for VHT20 / VHT40, therefore investigated worst case to representative mode in test report.

2. The EUT contains following accessory devices:

Product	Brand	Model	Description
AC Adapter	EDACPOWER ELEC	EA10731J-120	Input: 100-240Vac, 2A, 50-60Hz Output: 12V, 5A, 60W Length: 1.7m, with one core
Power cord	Xinbaihui	XBH-M31	1.6m

3. The above EUT information is declared by manufacturer and for more detailed features description, please refer the manufacturer's or user's manual.

Underwriters Laboratories Taiwan Co., Ltd.

Building B and Building E, No. 372-7, Sec. 4, Zhongxing Rd., Zhudong Township, Hsinchu County, Taiwan

Telephone :+886-2-7737-3000

Facsimile (FAX) :+886-3-583-7948

Doc No: 17-EM-F0878 / 6.0



6.2. Channel List

FOR 5180 ~ 5240MHz

4 channels are provided for 802.11a, 802.11n (HT20), 802.11ac (VHT20):

Channel	Frequency	Channel	Frequency
36	5180 MHz	44	5220 MHz
40	5200 MHz	48	5240 MHz

2 channels are provided for 802.11n (HT40), 802.11ac (VHT40):

Channel	Frequency	Channel	Frequency
38	5190 MHz	46	5230 MHz

1 channel is provided for 802.11ac (VHT80):

Channel	Frequency
42	5210MHz

FOR 5260 ~ 5320MHz

4 channels are provided for 802.11a, 802.11n (HT20), 802.11ac (VHT20):

Channel	Frequency	Channel	Frequency
52	5260 MHz	60	5300 MHz
56	5280 MHz	64	5320 MHz

2 channels are provided for 802.11n (HT40), 802.11ac (VHT40):

Channel	Frequency	Channel	Frequency
54	5270 MHz	62	5310 MHz

1 channel is provided for 802.11ac (VHT80):

Channel	Frequency
58	5290MHz

Underwriters Laboratories Taiwan Co., Ltd.

Building B and Building E, No. 372-7, Sec. 4, Zhongxing Rd., Zhudong Township, Hsinchu County, Taiwan

Telephone :+886-2-7737-3000

Facsimile (FAX) :+886-3-583-7948

Doc No: 17-EM-F0878 / 6.0



FOR 5500 ~ 5700MHz

11 channels are provided for 802.11a, 802.11n (HT20), 802.11ac (VHT20):

Channel	Frequency	Channel	Frequency
100	5500 MHz	124	5620 MHz
104	5520 MHz	128	5640 MHz
108	5540 MHz	132	5660 MHz
112	5560 MHz	136	5680 MHz
116	5580 MHz	140	5700 MHz
120	5600 MHz	-	-

5 channels are provided for 802.11n (HT40), 802.11ac (VHT40):

Channel	Frequency	Channel	Frequency
102	5510 MHz	126	5630 MHz
110	5550 MHz	134	5670 MHz
118	5590 MHz	-	-

2 channels are provided for 802.11ac (VHT80):

Channel	Frequency	Channel	Frequency
106	5530MHz	122	5610 MHz

FOR 5745 ~ 5825MHz:

5 channels are provided for 802.11a, 802.11n (HT20), 802.11ac (VHT20):

Channel	Frequency	Channel	Frequency
149	5745MHz	161	5805MHz
153	5765MHz	165	5825MHz
157	5785MHz	-	-

2 channels are provided for 802.11n (HT40), 802.11ac (VHT40):

Channel	Frequency	Channel	Frequency
151	5755MHz	159	5795MHz

1 channel is provided for 802.11ac (VHT80):

Channel	Frequency
155	5775MHz

Underwriters Laboratories Taiwan Co., Ltd.

Building B and Building E, No. 372-7, Sec. 4, Zhongxing Rd., Zhudong Township, Hsinchu County, Taiwan

Telephone :+886-2-7737-3000

Facsimile (FAX) :+886-3-583-7948

Doc No: 17-EM-F0878 / 6.0



6.3. Test Condition

Test Item	Test Site No.	Environmental Condition	Input Power	Test Date	Tested by
Antenna Port Conducted Measurement	SR4	22~26°C/ 62~68%RH	120Vac/ 60Hz	2022/04/14~ 2022/04/22	Mike Cai
Radiated Spurious Emission	966-2	22~26°C/ 62~68%RH	120Vac/ 60Hz	2022/04/14~ 2022/04/22	Mike Cai
AC power Line Conducted Emission	SR1	22~26°C/ 62~68%RH	120Vac/ 60Hz	2022/04/22~ 2022/04/22	Mike Cai

FCC Test Firm Registration Number: 498077

6.4. Description of Available Antennas

Ant. No.	Transmitter Circuit	Brand Name	Model Name	Ant. Type	Maximum Gain (dBi)
1	Chain (0)+(1)	InnoComm Mobile	N/A	PCB	2.4GHz: 3.3 5GHz: 3.53
2	Chain (0)+(1)	InnoComm Mobile	N/A	PCB	2.4GHz: 3.91 5GHz: 3.83

Note: The above antenna information was provided from customer and for more detailed features description, please refer the manufacturer's specification or user's manual.

Underwriters Laboratories Taiwan Co., Ltd.

Building B and Building E, No. 372-7, Sec. 4, Zhongxing Rd., Zhudong Township, Hsinchu County, Taiwan

Telephone :+886-2-7737-3000

Facsimile (FAX) :+886-3-583-7948

Doc No: 17-EM-F0878 / 6.0



6.5. Test Mode Applicability and Tested Channel Detail

- The fundamental of the Antenna was investigated in three orthogonal axes X-Y/Y-Z/X-Z, it was determined that X-Z plane was worst-case. Therefore, all final radiated testing was performed with the Antenna in X-Z plane.
- For Antenna Port Conducted Measurement, this item includes all test value of each mode, but only includes spectrum plot of worst value of each mode.
- For below 30MHz testing, investigation was done on three antenna orientations (parallel, perpendicular, and ground-parallel), parallel and perpendicular are the worst orientations, therefore testing was performed on these two orientations only.
- For below 1 GHz radiated emission and AC power line conducted emission have performed all modes of operation were investigated and the worst-case emissions are reported.
- Pre-Scan has been conducted to determine the worst-case mode from all possible combinations between available modulations, data rates and antenna ports (if EUT with antenna diversity architecture).

Test Item	Mode	Modulation Technology	Modulation Type	Available Channel	Test Channel	Data Rate
Radiated Emissions (Above 1GHz)	802.11a	5180-5240	OFDM	36 to 48	36, 44, 48	6Mbps
	802.11ac20		OFDM	36 to 48	36, 44, 48	MCS0
	802.11ac40			38 to 46	38, 46	MCS0
	802.11ac80			42	42	MCS0
	802.11a	5260-5320	OFDM	52 to 64	52, 60, 64	6Mbps
	802.11ac20		OFDM	52 to 64	52, 60, 64	MCS0
	802.11ac40			54 to 62	54, 62	MCS0
	802.11ac80			58	58	MCS0
	802.11a	5500-5700	OFDM	100 to 140	100, 116, 140	6Mbps
	802.11ac20		OFDM	100 to 140	100, 116, 140	MCS0
	802.11ac40			102 to 134	102, 110, 134	MCS0
	802.11ac80			106, 122	106, 122	MCS0
	802.11a	5745-5825	OFDM	149 to 165	149, 157, 165	6Mbps
	802.11ac20		OFDM	149 to 165	149, 157, 165	MCS0
	802.11ac40			151 to 159	151, 159	MCS0
	802.11ac80			155	155	MCS0
Radiated Emissions (Below 1GHz)	802.11a	5745-5825	OFDM	149 to 165	165	6Mbps
AC Power Line Conducted Emission	802.11a	5745-5825	OFDM	149 to 165	165	6Mbps

Underwriters Laboratories Taiwan Co., Ltd.

Building B and Building E, No. 372-7, Sec. 4, Zhongxing Rd., Zhudong Township, Hsinchu County, Taiwan

Telephone :+886-2-7737-3000

Facsimile (FAX) :+886-3-583-7948

Doc No: 17-EM-F0878 / 6.0



Test Item	Mode	Modulation Technology	Modulation Type	Available Channel	Test Channel	Data Rate
Antenna Port Conducted Measurement	802.11a	5180-5240	OFDM	36 to 48	36, 44, 48	6Mbps
	802.11ac20		OFDM	36 to 48	36, 44, 48	MCS0
	802.11ac40			38 to 46	38, 46	MCS0
	802.11ac80			42	42	MCS0
	802.11a	5260-5320	OFDM	52 to 64	52, 60, 64	6Mbps
	802.11ac20		OFDM	52 to 64	52, 60, 64	MCS0
	802.11ac40			54 to 62	54, 62	MCS0
	802.11ac80			58	58	MCS0
	802.11a	5500-5700	OFDM	100 to 140	100, 116, 140	6Mbps
	802.11ac20		OFDM	100 to 140	100, 116, 140	MCS0
	802.11ac40			102 to 134	102, 110, 134	MCS0
	802.11ac80			106, 122	106, 122	MCS0
	802.11a	5745-5825	OFDM	149 to 165	149, 157, 165	6Mbps
	802.11ac20		OFDM	149 to 165	149, 157, 165	MCS0
	802.11ac40			151 to 159	151, 159	MCS0
	802.11ac80			155	155	MCS0

Underwriters Laboratories Taiwan Co., Ltd.

Building B and Building E, No. 372-7, Sec. 4, Zhongxing Rd., Zhudong Township, Hsinchu County, Taiwan

Telephone :+886-2-7737-3000

Facsimile (FAX) :+886-3-583-7948

Doc No: 17-EM-F0878 / 6.0



6.6. Duty cycle

Mode	On Time (ms)	On+Off Time (ms)	Duty Cycle	Duty Factor (dB)	VBW Set (above 1GHz)
802.11a	1.380	1.448	0.95	0.21	1kHz
802.11ac(VHT20)	1.300	1.365	0.95	0.21	1kHz
802.11ac(VHT40)	0.651	0.706	0.92	0.35	2kHz
802.11ac(VHT80)	0.324	0.377	0.86	0.66	5.1kHz

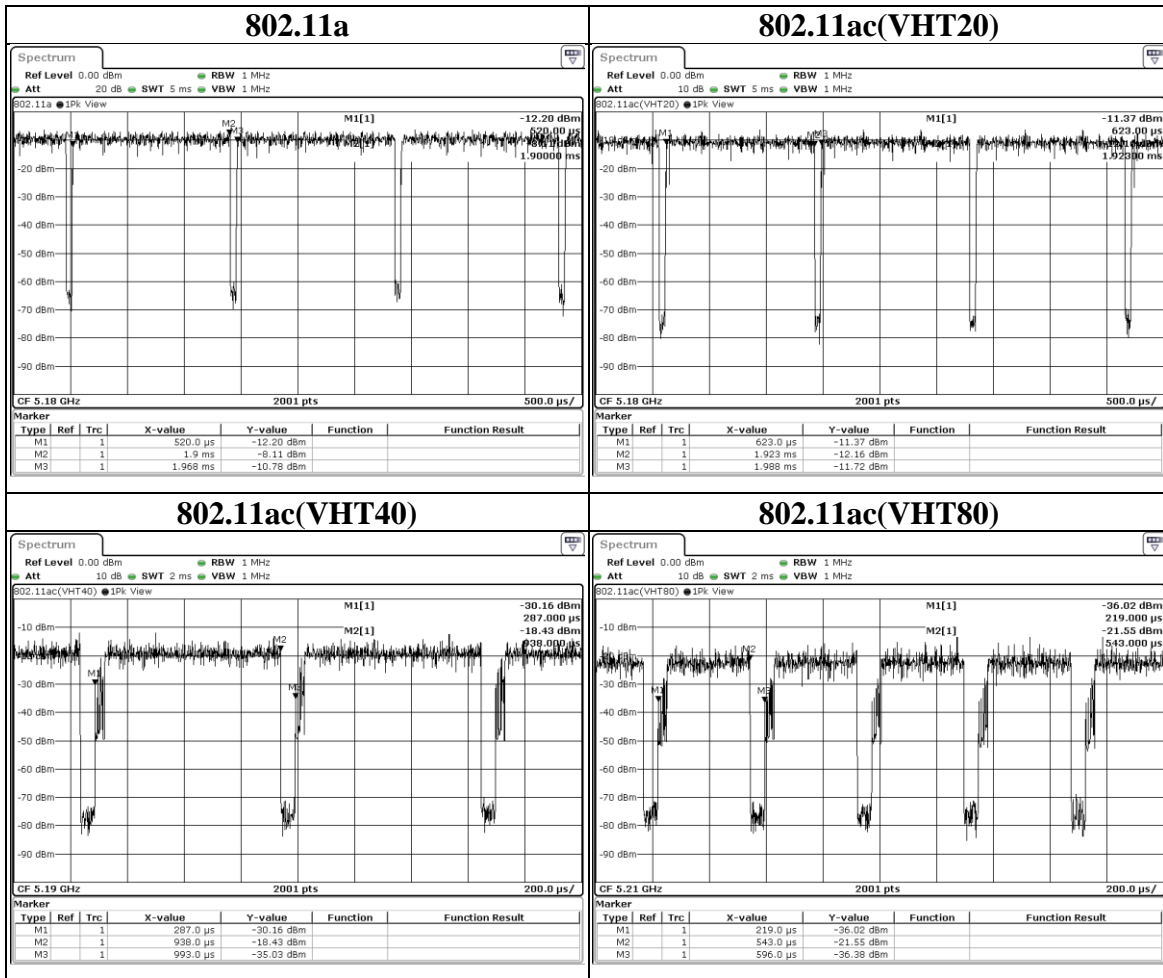

Underwriters Laboratories Taiwan Co., Ltd.

Building B and Building E, No. 372-7, Sec. 4, Zhongxing Rd., Zhudong Township, Hsinchu County, Taiwan

Telephone : +886-2-7737-3000

Facsimile (FAX) : +886-3-583-7948

Doc No: 17-EM-F0878 / 6.0



7. Test Equipment

Test Equipment List					
Equipment	Manufacturer	Model No.	Serial No.	Cal. Date	Expired date
Radiated Spurious Emission					
Spectrum Analyzer	Keysight	N9010A	MY56070827	2021/11/9	2022/11/8
EMI Test Receiver	Rohde & Schwarz	ESR7	101754	2021/12/10	2022/12/9
Loop Antenna	ETS lindgren	6502	00213440	2021/12/23	2022/12/22
Trilog-Broadband Antenna with 5dB Attenuator	Schwarzbeck & EMCI	VULB 9168 & N-6-05	774 & AT-N0538	2022/2/8	2023/2/7
Horn Antenna (1-18 GHz)	Schwarzbeck	BBHA 9120 D	01690	2021/12/13	2022/12/12
Horn Antenna (18-40 GHz)	Schwarzbeck	BBHA 9170	781	2021/12/17	2022/12/16
Preamplifier (30-1000 MHz)	EMCI	EMC330E	980405	2021/6/8	2022/6/7
Preamplifier (1-18 GHz)	EMCI	EMC051835BE	980406	2022/2/16	2023/2/15
Preamplifier (18-40GHz)	EMCI	EMC184040SEE	980426	2021/5/19	2022/5/18
Cables	Hanyitek	K1K50-UP0264-K1K50-2500	170214-4 & 170425-2	2021/12/3	2022/12/2
Cables	Hanyitek	K1K50-UP0264-K1K50-2500	170214-1 & 170214-2	2021/12/3	2022/12/2

Underwriters Laboratories Taiwan Co., Ltd.

Building B and Building E, No. 372-7, Sec. 4, Zhongxing Rd., Zhudong Township, Hsinchu County, Taiwan

Telephone :+886-2-7737-3000

Facsimile (FAX) :+886-3-583-7948

Doc No: 17-EM-F0878 / 6.0



Test report No. : 4790358903-US-R1-V0
Page : 17 of 154
Issued date : 2022/6/7
FCC ID : 2A4GY-LB-TABLET01

Test Equipment List					
Equipment	Manufacturer	Model No.	Serial No.	Cal. Date	Expired date
Antenna Port Conducted Measurement					
Spectrum Analyzer	Keysight	N9010A	MY56070834	2021/10/29	2022/10/28
Pulse Power Sensor	Anritsu	MA2411B	1531202	2021/12/22	2022/12/21
Power Meter	Anritsu	ML2495A	1645002	2021/12/22	2022/12/21
Temperature & Humidity Test Chamber	GIANT FORCE	GTH-150-40-CP-AR	MAA1701-010	2022/3/11	2023/3/10
AC power Line Conducted Emission					
EMI Test Receiver	Rohde & Schwarz	ESR7	101753	2021/11/15	2022/11/14
Two-Line V-Network	Rohde & Schwarz	ENV216	102136	2021/8/30	2022/8/29
Impuls-Begrenzer Pulse Limiter	Rohde & Schwarz	ESH3-Z2	102219-Qt	2021/8/26	2022/8/25
Cables	TITAN	CFD200	T0732ACFD20 020A300-1	2022/3/16	2023/3/15

UL Software		
Description	Name	Version
Radiated measurement	e3	6.191211 (V6)
Conducted measurement	RF Conducted Test Tools	ver 2.4.0.620b
AC power Line Conducted Emission	EZ_EMCC	UL-3A1.2

Underwriters Laboratories Taiwan Co., Ltd.

Building B and Building E, No. 372-7, Sec. 4, Zhongxing Rd., Zhudong Township, Hsinchu County, Taiwan

Telephone :+886-2-7737-3000

Facsimile (FAX) :+886-3-583-7948

Doc No: 17-EM-F0878 / 6.0



8. Description of Test Setup

Support Equipment

ID	Equipment	Brand Name	Model Name	S/N	Remark
A	Laptop	Lenovo	T460	PC0FWU5Y	Provide by lab
B	Adapter	EDACPOWER ELEC	EA10731J-120	NA	Provide by client

I/O Cables

ID	Equipment	Brand Name	Model Name	Length (m)	Remark
1	Micro USB Cable	fujiei	Z08145	1	Provide by lab
2	DC Cable	EDACPOWER ELEC	EA10731J-120	1.7	Provide by client with one core
3	AC Cable	Xinbaihui	XBH-M31	1.6	Provide by client

Underwriters Laboratories Taiwan Co., Ltd.

Building B and Building E, No. 372-7, Sec. 4, Zhongxing Rd., Zhudong Township, Hsinchu County, Taiwan

Telephone :+886-2-7737-3000

Facsimile (FAX) :+886-3-583-7948

Doc No: 17-EM-F0878 / 6.0



Test Setup

Controlled using a bespoke application (cmd(command)) on a test Notebook. The application was used to enable a continuous transmission mode and to select the test channels, data rates, modulation schemes and power setting as required.

Setup Diagram for Test

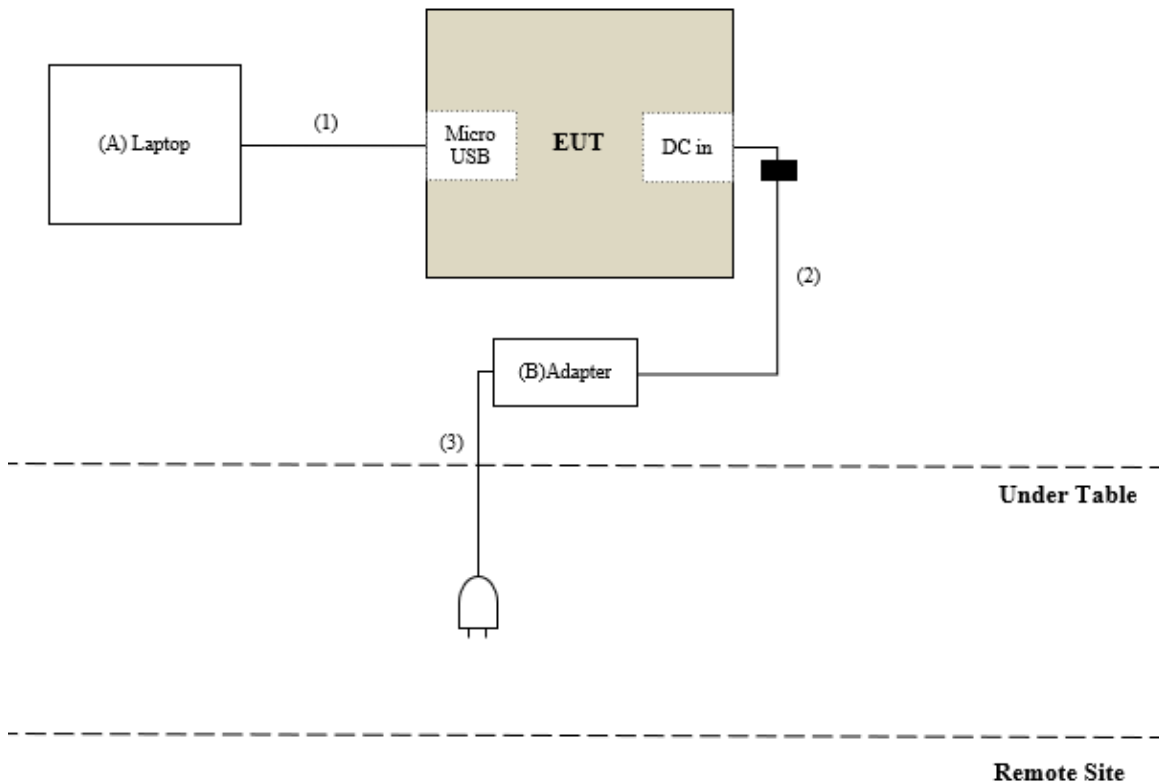

Underwriters Laboratories Taiwan Co., Ltd.

Building B and Building E, No. 372-7, Sec. 4, Zhongxing Rd., Zhudong Township, Hsinchu County, Taiwan

Telephone :+886-2-7737-3000

Facsimile (FAX) :+886-3-583-7948

Doc No: 17-EM-F0878 / 6.0



9. Test Results

9.1. 6dB Bandwidth

Requirements

The minimum 6 dB bandwidth shall be at least 500 kHz.

Test procedure

- Set resolution bandwidth (RBW) = 100kHz
- Set the video bandwidth (VBW) $\geq 3 \times$ RBW, Detector = Peak.
- Trace mode = max hold.
- Sweep = auto couple.
- Measure the maximum width of the emission that is constrained by the frequencies associated with the two amplitude points (upper and lower) that are attenuated by 6 dB relative to the maximum level measured in the fundamental emission

Test Setup

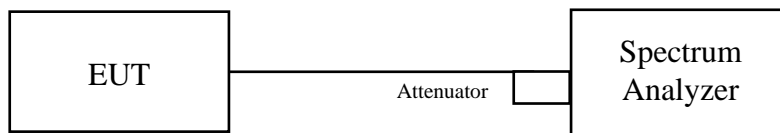

The loss between RF output port of the EUT and the input port of the Spectrum Analyzer has been taken into consideration.

Underwriters Laboratories Taiwan Co., Ltd.

Building B and Building E, No. 372-7, Sec. 4, Zhongxing Rd., Zhudong Township, Hsinchu County, Taiwan

Telephone :+886-2-7737-3000

Facsimile (FAX) :+886-3-583-7948

Doc No: 17-EM-F0878 / 6.0



Test Data

Mode	CH	Freq (MHz)	6dB BW (MHz)		Limit (MHz)	Result
			Chain 0	Chain 1		
802.11a	149	5745	13.811	15.127	0.5	Pass
	157	5785	13.877	14.694	0.5	Pass
	165	5825	14.122	14.463	0.5	Pass

Underwriters Laboratories Taiwan Co., Ltd.

Building B and Building E, No. 372-7, Sec. 4, Zhongxing Rd., Zhudong Township, Hsinchu County, Taiwan

Telephone :+886-2-7737-3000

Facsimile (FAX) :+886-3-583-7948

Doc No: 17-EM-F0878 / 6.0

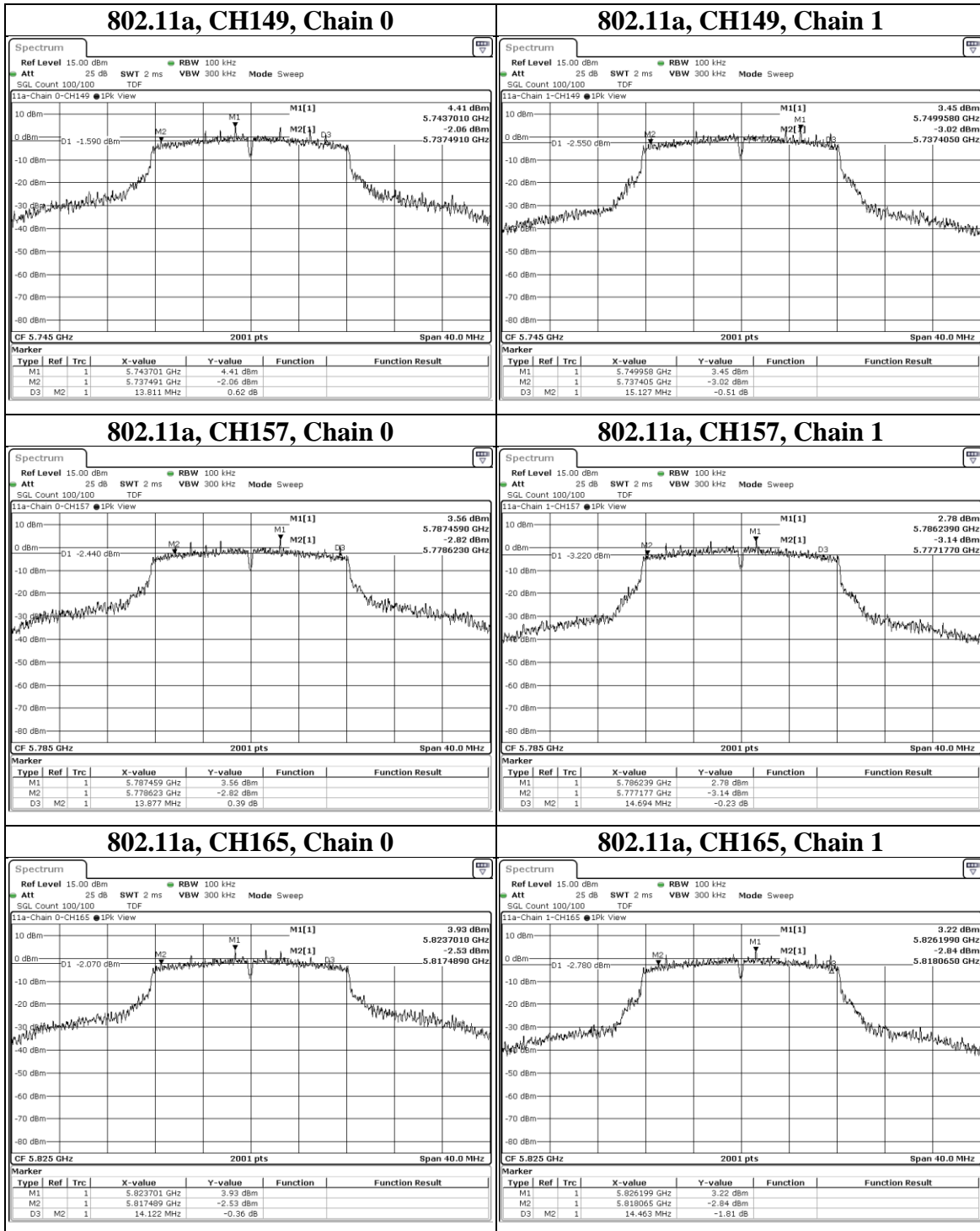



Test report No. : 4790358903-US-R1-V0
Page : 23 of 154
Issued date : 2022/6/7
FCC ID : 2A4GY-LB-TABLET01

Mode	CH	Freq (MHz)	6dB BW (MHz)		Limit (MHz)	Result
			Chain 0	Chain 1		
802.11ac(VHT20)	149	5745	15.918	14.467	0.5	Pass
	157	5785	15.106	15.04	0.5	Pass
	165	5825	15.115	13.201	0.5	Pass

Underwriters Laboratories Taiwan Co., Ltd.

Building B and Building E, No. 372-7, Sec. 4, Zhongxing Rd., Zhudong Township, Hsinchu County, Taiwan

Telephone :+886-2-7737-3000

Facsimile (FAX) :+886-3-583-7948

Doc No: 17-EM-F0878 / 6.0

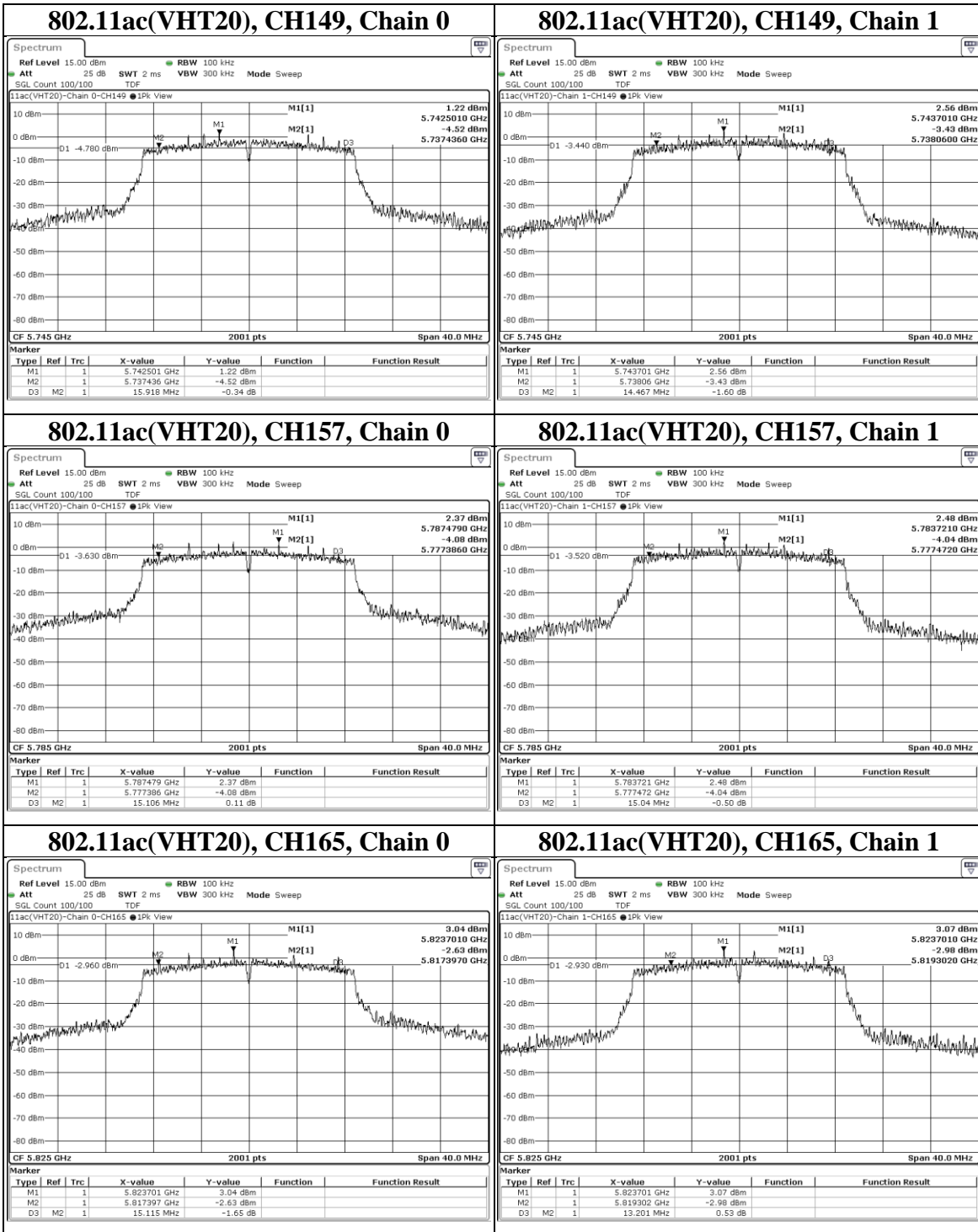

Underwriters Laboratories Taiwan Co., Ltd.

Building B and Building E, No. 372-7, Sec. 4, Zhongxing Rd., Zhudong Township, Hsinchu County, Taiwan

Telephone : +886-2-7737-3000

Facsimile (FAX) : +886-3-583-7948



Mode	CH	Freq (MHz)	6dB BW (MHz)		Limit (MHz)	Result
			Chain 0	Chain 1		
802.11ac(VHT40)	151	5755	32.548	35.052	0.5	Pass
	159	5795	33.915	35.124	0.5	Pass

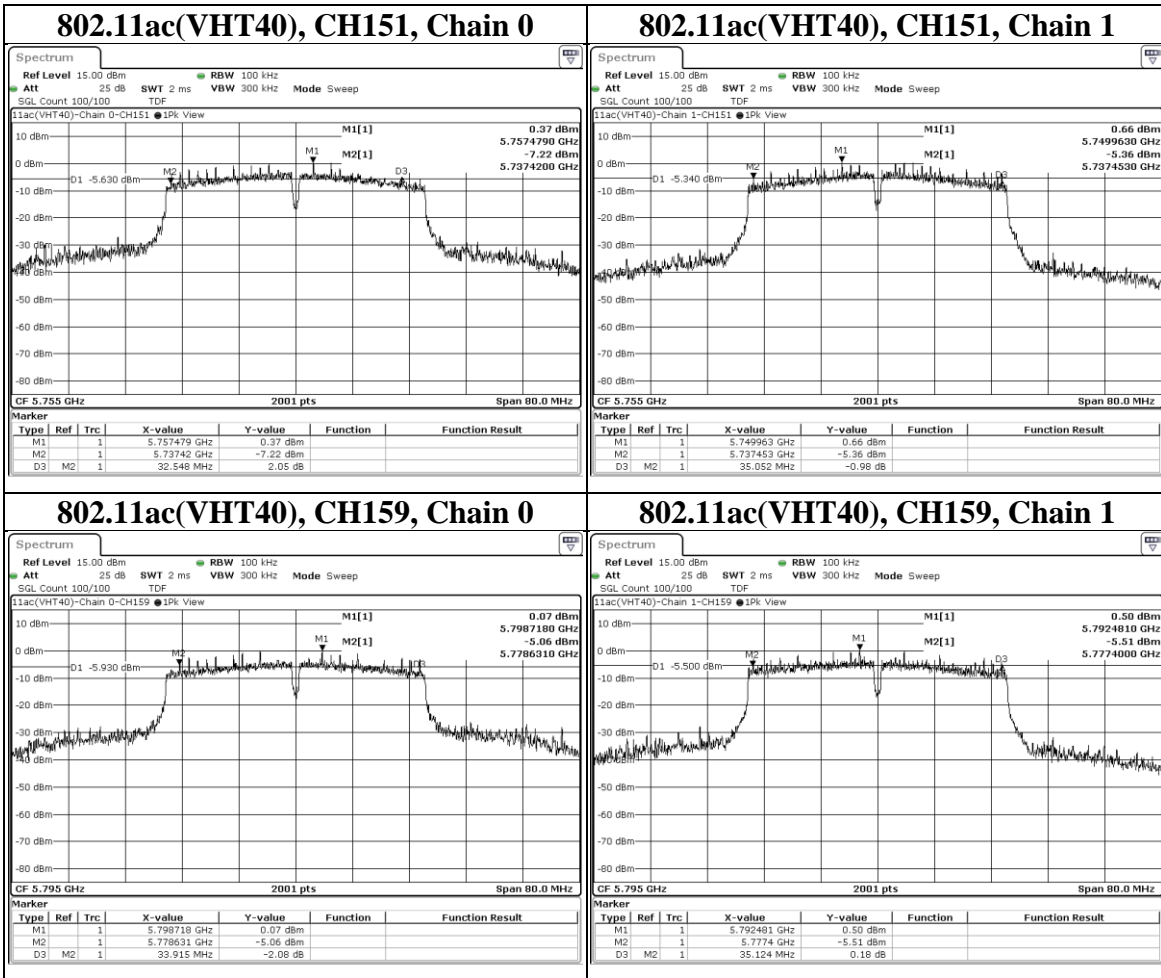

Underwriters Laboratories Taiwan Co., Ltd.

Building B and Building E, No. 372-7, Sec. 4, Zhongxing Rd., Zhudong Township, Hsinchu County, Taiwan

Telephone : +886-2-7737-3000

Facsimile (FAX) : +886-3-583-7948



Mode	CH	Freq (MHz)	6dB BW (MHz)		Limit (MHz)	Result
			Chain 0	Chain 1		
802.11ac(VHT80)	155	5775	75.185	73.888	0.5	Pass

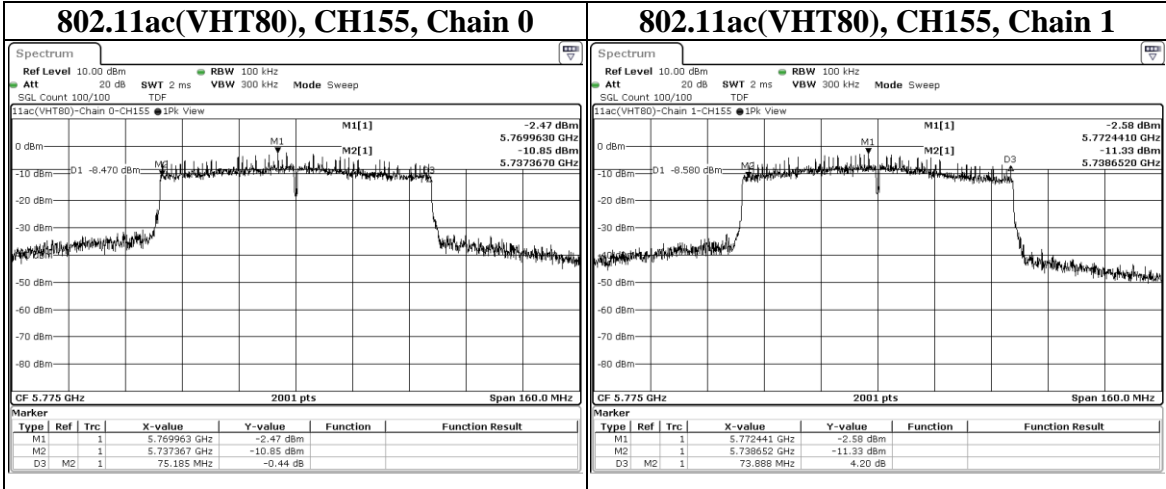

Underwriters Laboratories Taiwan Co., Ltd.

Building B and Building E, No. 372-7, Sec. 4, Zhongxing Rd., Zhudong Township, Hsinchu County, Taiwan

Telephone :+886-2-7737-3000

Facsimile (FAX) :+886-3-583-7948



9.2. 26dB Bandwidth

Test procedure

- Set RBW = approximately 1% of the emission bandwidth.
- Set the VBW > RBW.
- Detector = Peak.
- Trace mode = max hold.
- Measure the maximum width of the emission that is 26 dB down from the peak of the emission. Compare this with the RBW setting of the analyzer. Readjust RBW and repeat measurement as needed until the RBW/EBW ratio is approximately 1%.

Test Setup

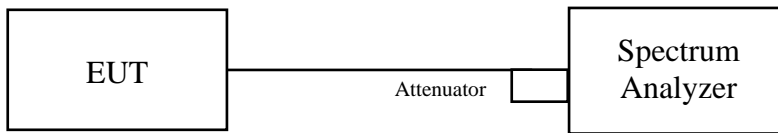

The loss between RF output port of the EUT and the input port of the Spectrum Analyzer has been taken into consideration.

Underwriters Laboratories Taiwan Co., Ltd.

Building B and Building E, No. 372-7, Sec. 4, Zhongxing Rd., Zhudong Township, Hsinchu County, Taiwan

Telephone :+886-2-7737-3000

Facsimile (FAX) :+886-3-583-7948

Doc No: 17-EM-F0878 / 6.0



Test Data

Mode	CH	Freq (MHz)	26dB BW (MHz)		Limit (MHz)	Result
			Chain 0	Chain 1		
802.11a	36	5180	19.708	19.807	N/A	Pass
	44	5220	20.115	19.524	N/A	Pass
	48	5240	20.137	19.439	N/A	Pass
	52	5260	20.231	19.695	N/A	Pass
	60	5300	19.901	19.922	N/A	Pass
	64	5320	19.757	19.852	N/A	Pass
	100	5500	19.731	19.827	N/A	Pass
	116	5580	19.901	19.903	N/A	Pass
	140	5700	20.148	19.992	N/A	Pass

Underwriters Laboratories Taiwan Co., Ltd.

Building B and Building E, No. 372-7, Sec. 4, Zhongxing Rd., Zhudong Township, Hsinchu County, Taiwan

Telephone :+886-2-7737-3000

Facsimile (FAX) :+886-3-583-7948

Doc No: 17-EM-F0878 / 6.0

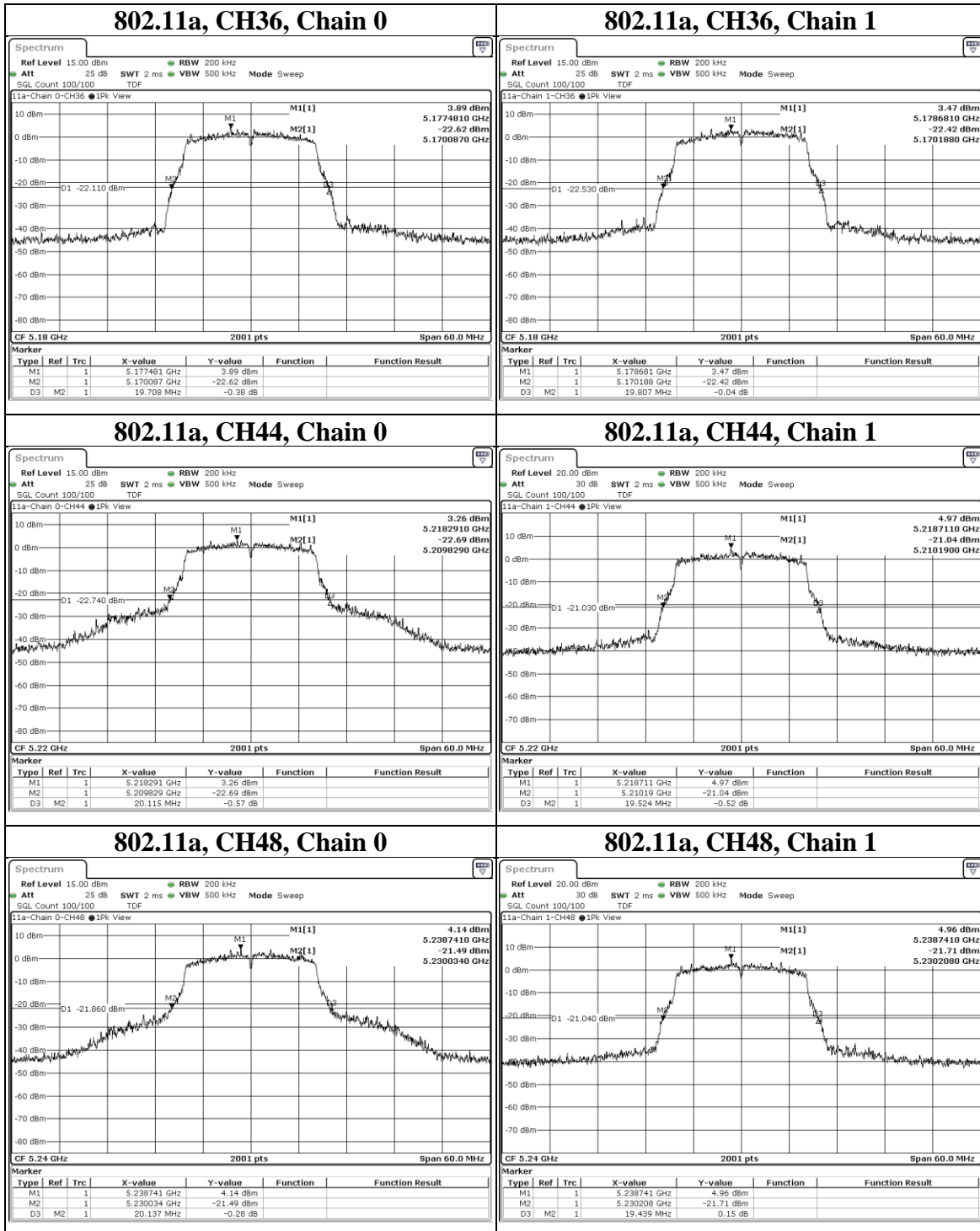

Underwriters Laboratories Taiwan Co., Ltd.

Building B and Building E, No. 372-7, Sec. 4, Zhongxing Rd., Zhudong Township, Hsinchu County, Taiwan

Telephone : +886-2-7737-3000

Facsimile (FAX) : +886-3-583-7948

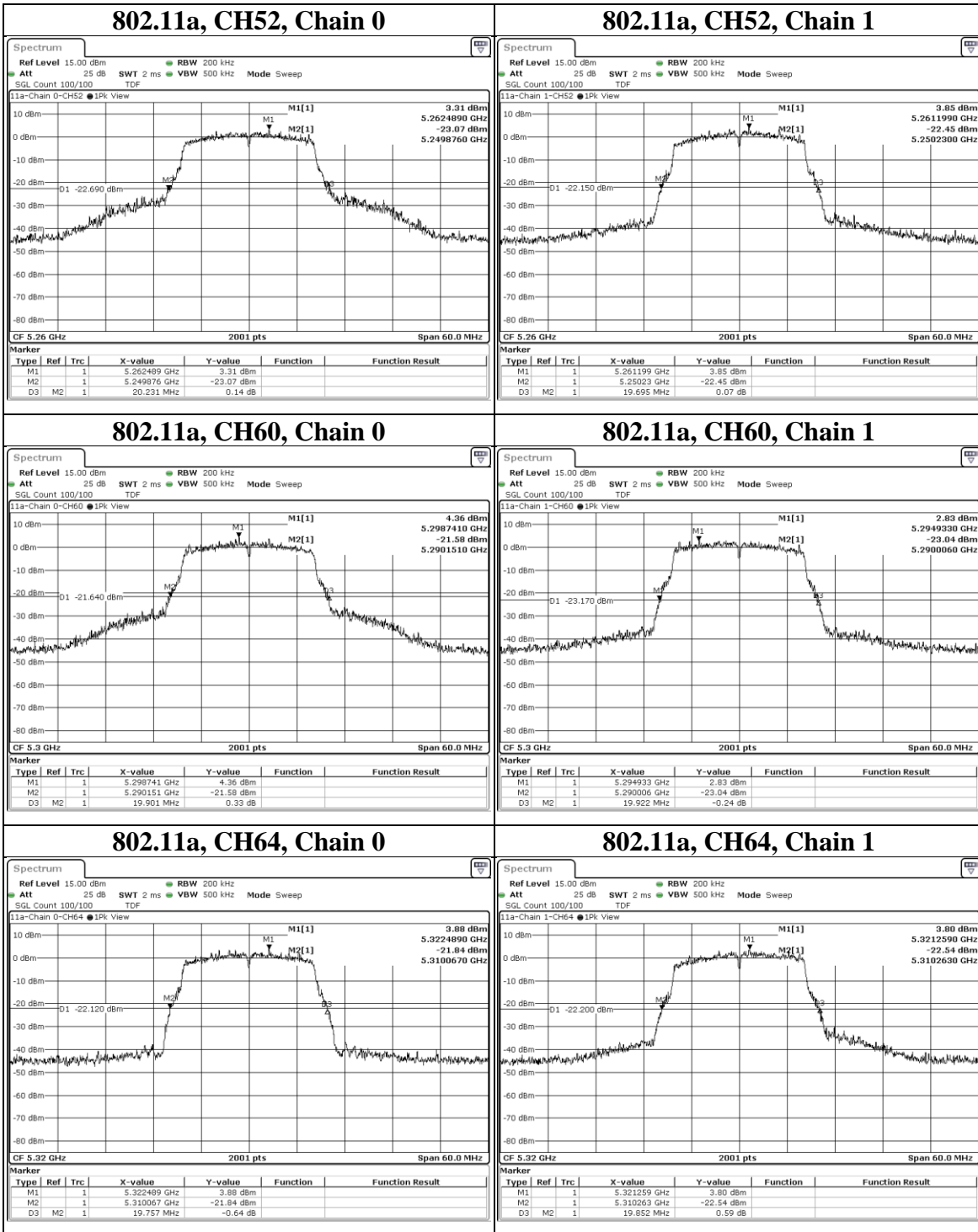

Underwriters Laboratories Taiwan Co., Ltd.

Building B and Building E, No. 372-7, Sec. 4, Zhongxing Rd., Zhudong Township, Hsinchu County, Taiwan

Telephone : +886-2-7737-3000

Facsimile (FAX) : +886-3-583-7948

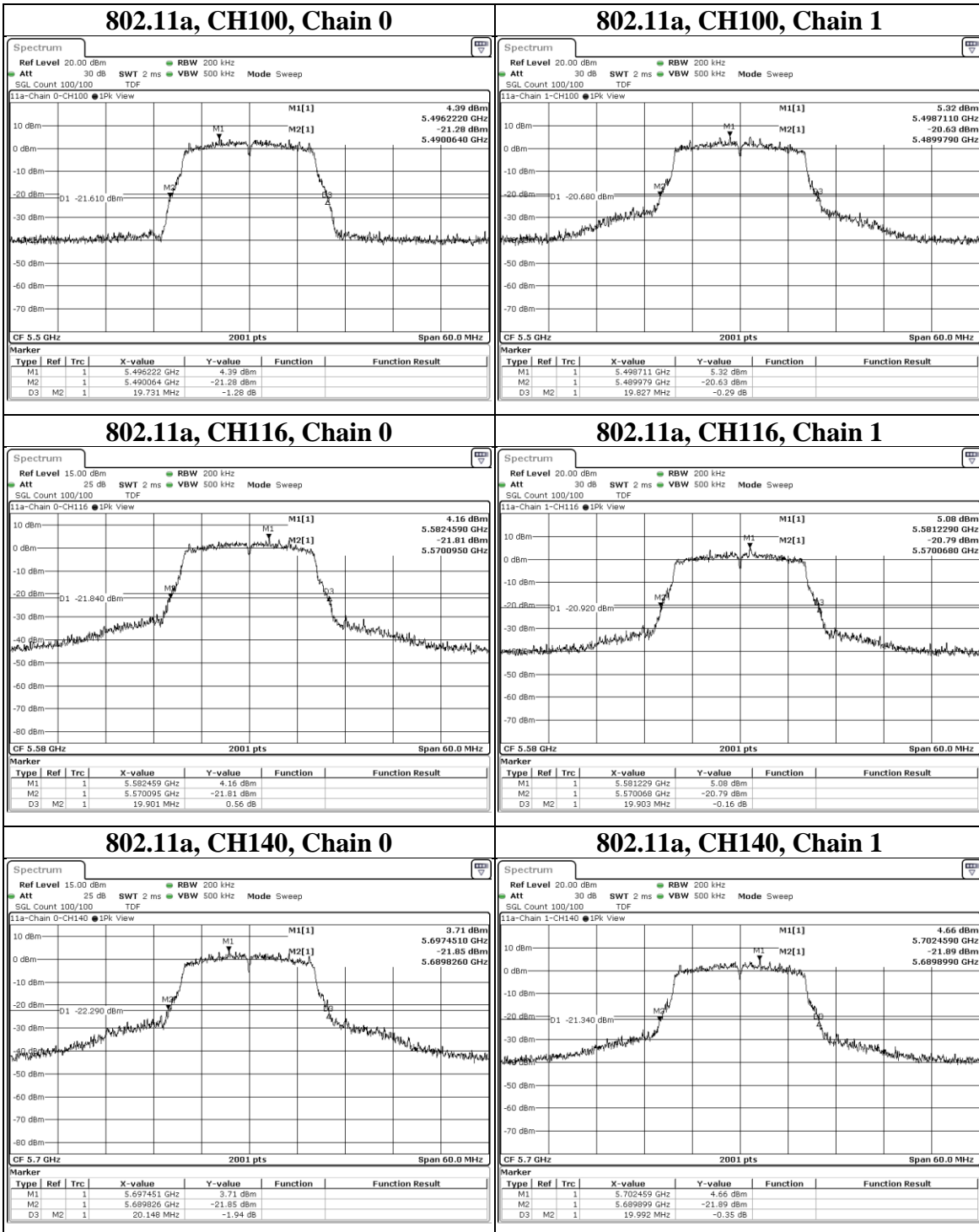



Test report No. : 4790358903-US-R1-V0
Page : 32 of 154
Issued date : 2022/6/7
FCC ID : 2A4GY-LB-TABLET01

Mode	CH	Freq (MHz)	26dB BW (MHz)		Limit (MHz)	Result
			Chain 0	Chain 1		
802.11ac(VHT20)	36	5180	19.952	19.792	N/A	Pass
	44	5220	20.056	19.739	N/A	Pass
	48	5240	20.085	19.871	N/A	Pass
	52	5260	20.311	19.874	N/A	Pass
	60	5300	19.985	19.753	N/A	Pass
	64	5320	19.907	19.574	N/A	Pass
	100	5500	19.93	19.778	N/A	Pass
	116	5580	20.017	19.938	N/A	Pass
	140	5700	19.983	19.941	N/A	Pass

Underwriters Laboratories Taiwan Co., Ltd.

Building B and Building E, No. 372-7, Sec. 4, Zhongxing Rd., Zhudong Township, Hsinchu County, Taiwan

Telephone :+886-2-7737-3000

Facsimile (FAX) :+886-3-583-7948

Doc No: 17-EM-F0878 / 6.0

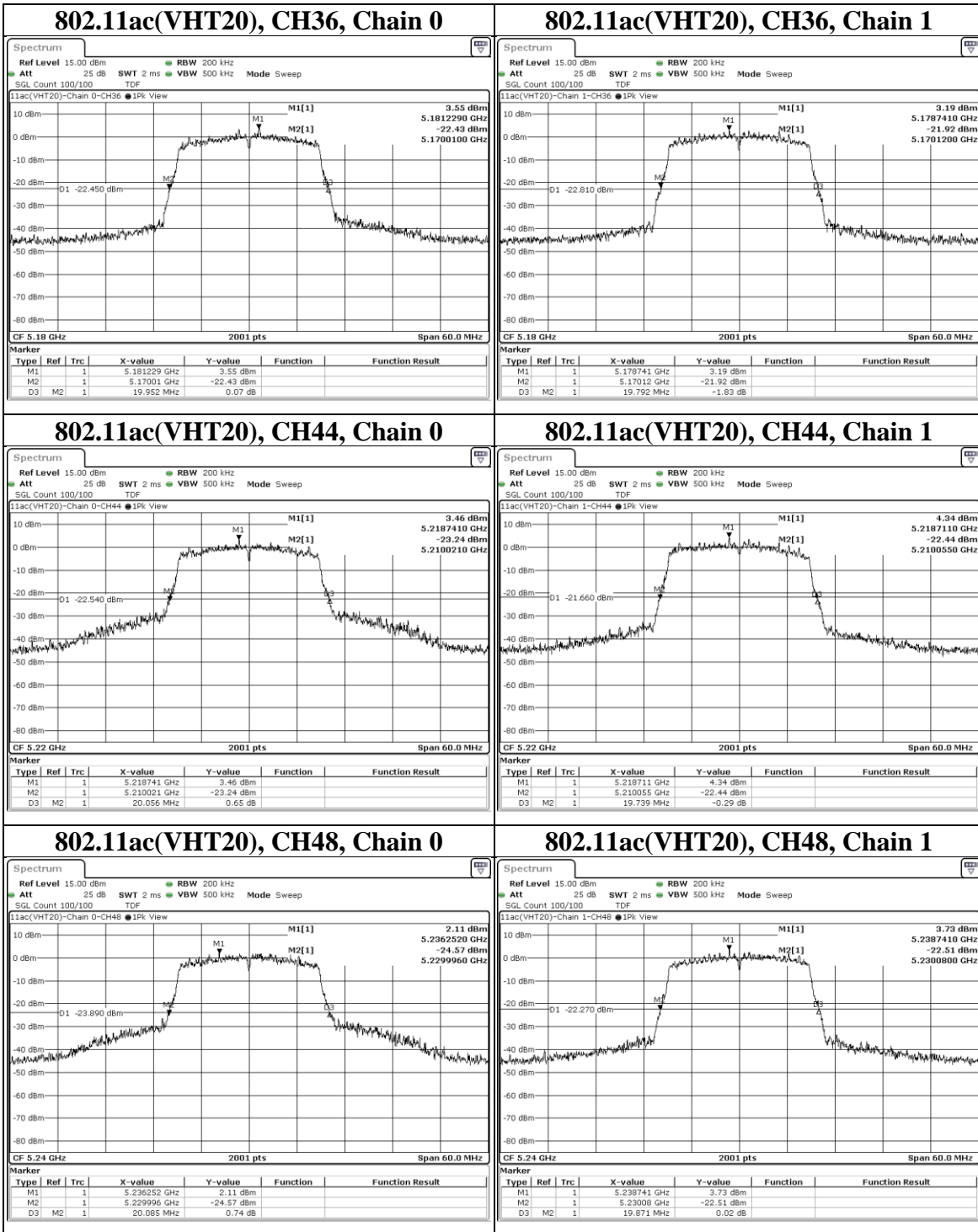

Underwriters Laboratories Taiwan Co., Ltd.

Building B and Building E, No. 372-7, Sec. 4, Zhongxing Rd., Zhudong Township, Hsinchu County, Taiwan

Telephone : +886-2-7737-3000

Facsimile (FAX) : +886-3-583-7948

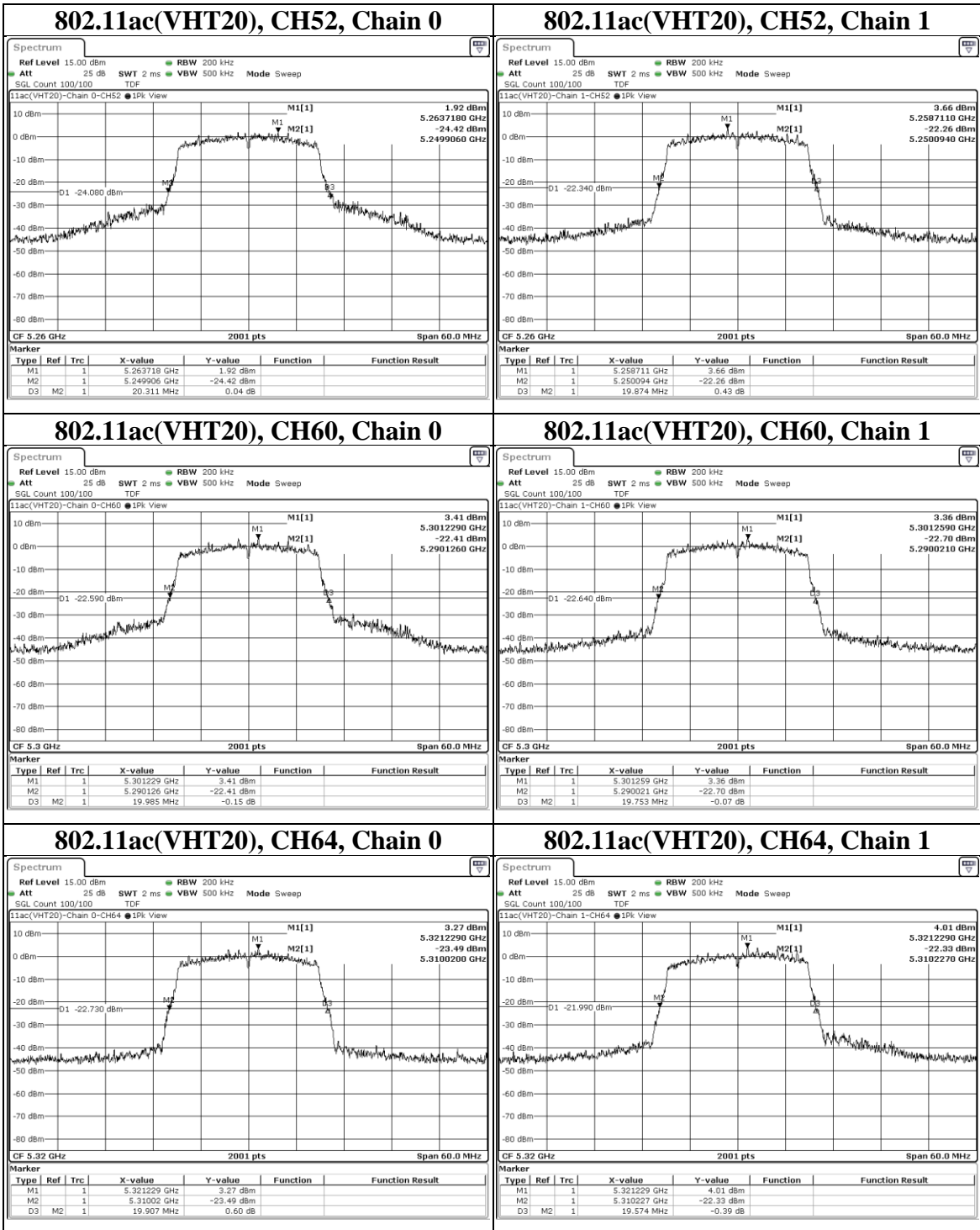

Underwriters Laboratories Taiwan Co., Ltd.

Building B and Building E, No. 372-7, Sec. 4, Zhongxing Rd., Zhudong Township, Hsinchu County, Taiwan

Telephone : +886-2-7737-3000

Facsimile (FAX) : +886-3-583-7948

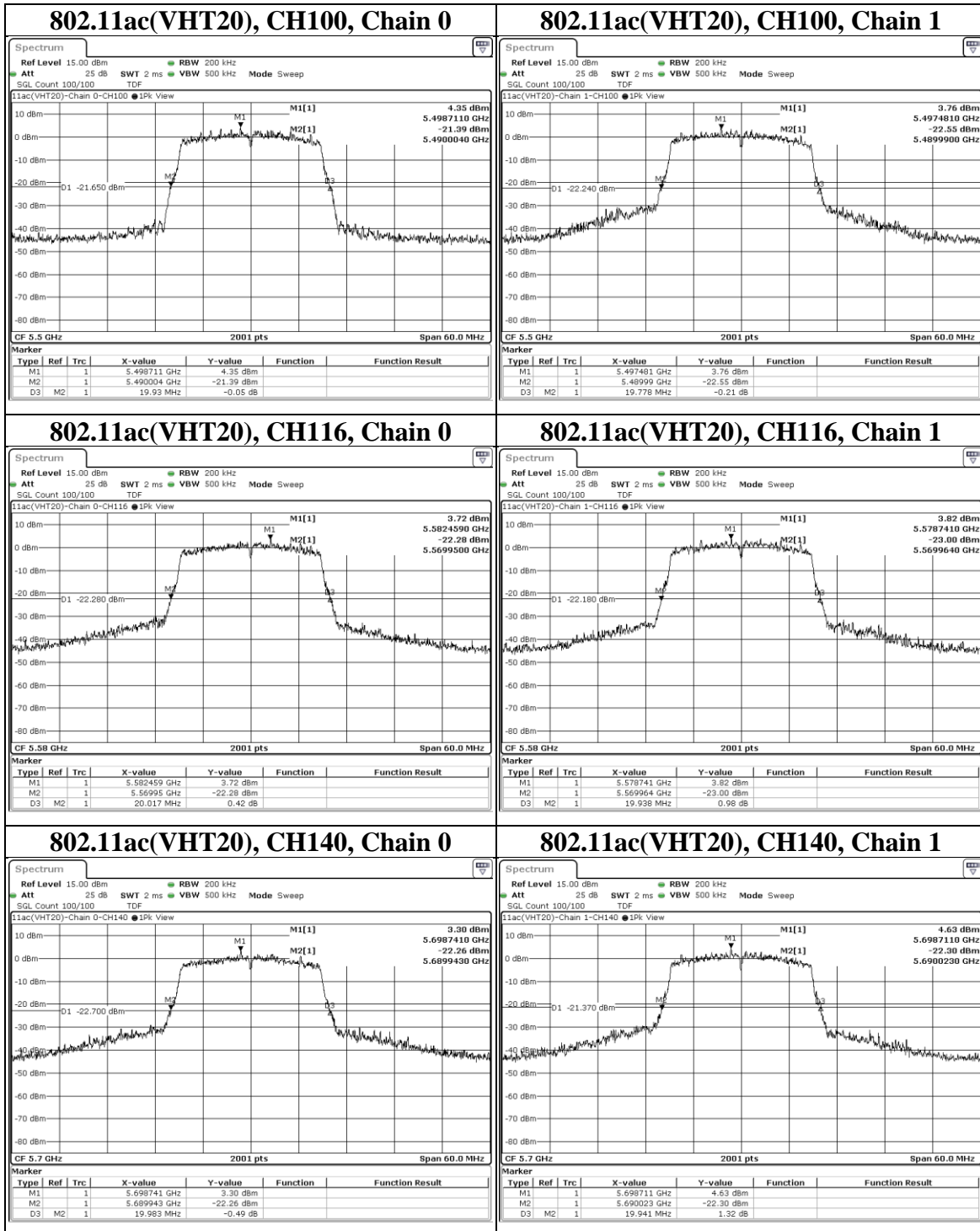

Underwriters Laboratories Taiwan Co., Ltd.

Building B and Building E, No. 372-7, Sec. 4, Zhongxing Rd., Zhudong Township, Hsinchu County, Taiwan

Telephone : +886-2-7737-3000

Facsimile (FAX) : +886-3-583-7948



Test report No. : 4790358903-US-R1-V0
Page : 36 of 154
Issued date : 2022/6/7
FCC ID : 2A4GY-LB-TABLET01

Mode	CH	Freq (MHz)	26dB BW (MHz)		Limit (MHz)	Result
			Chain 0	Chain 1		
802.11ac(VHT40)	38	5190	40.071	39.989	N/A	Pass
	46	5230	42.654	40.118	N/A	Pass
	54	5270	40.684	39.848	N/A	Pass
	62	5310	40.407	40.384	N/A	Pass
	102	5510	40.708	40.212	N/A	Pass
	110	5550	40.683	39.607	N/A	Pass
	134	5670	40.447	39.773	N/A	Pass

Underwriters Laboratories Taiwan Co., Ltd.

Building B and Building E, No. 372-7, Sec. 4, Zhongxing Rd., Zhudong Township, Hsinchu County, Taiwan

Telephone :+886-2-7737-3000

Facsimile (FAX) :+886-3-583-7948

Doc No: 17-EM-F0878 / 6.0

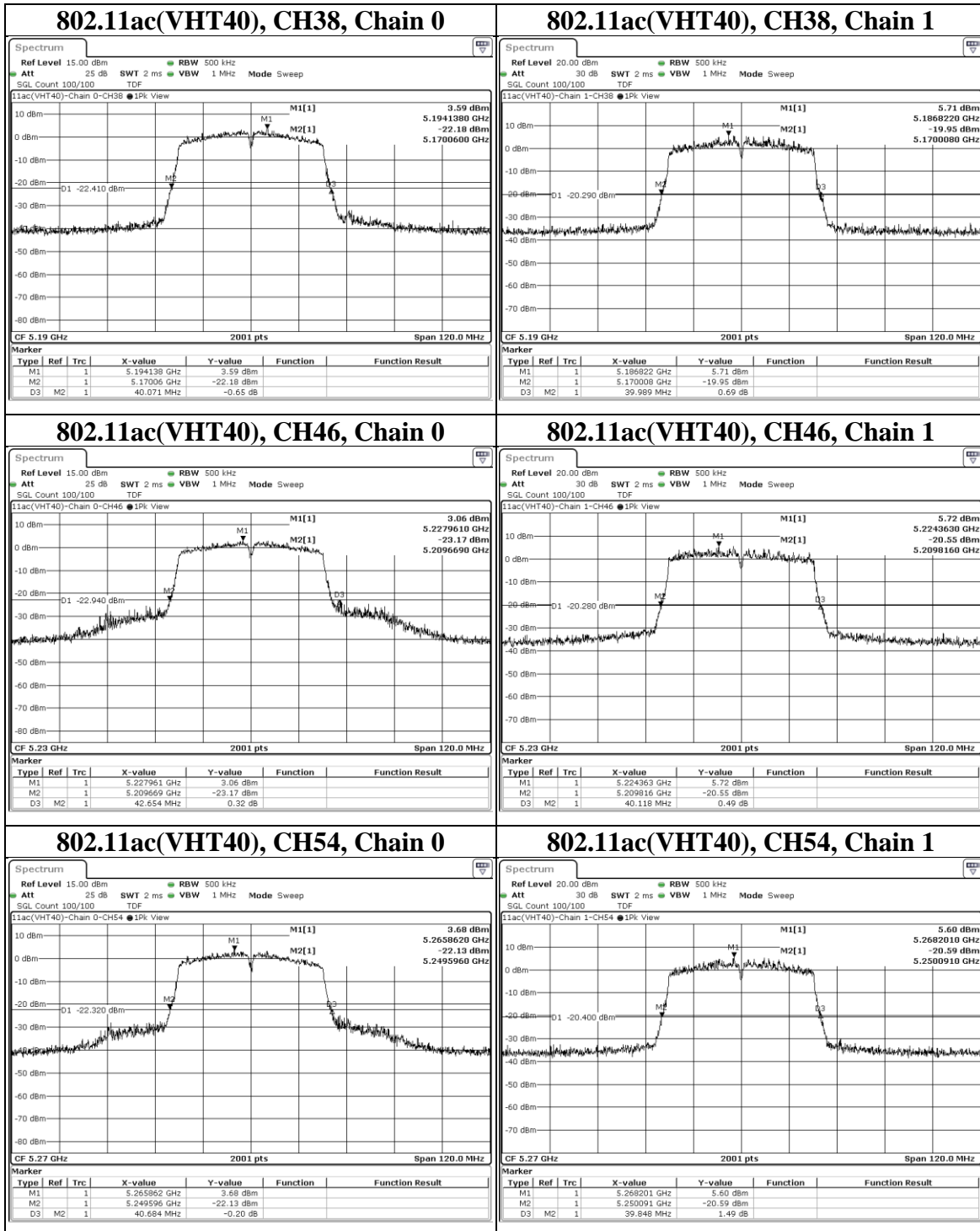

Underwriters Laboratories Taiwan Co., Ltd.

Building B and Building E, No. 372-7, Sec. 4, Zhongxing Rd., Zhudong Township, Hsinchu County, Taiwan

Telephone : +886-2-7737-3000

Facsimile (FAX) : +886-3-583-7948

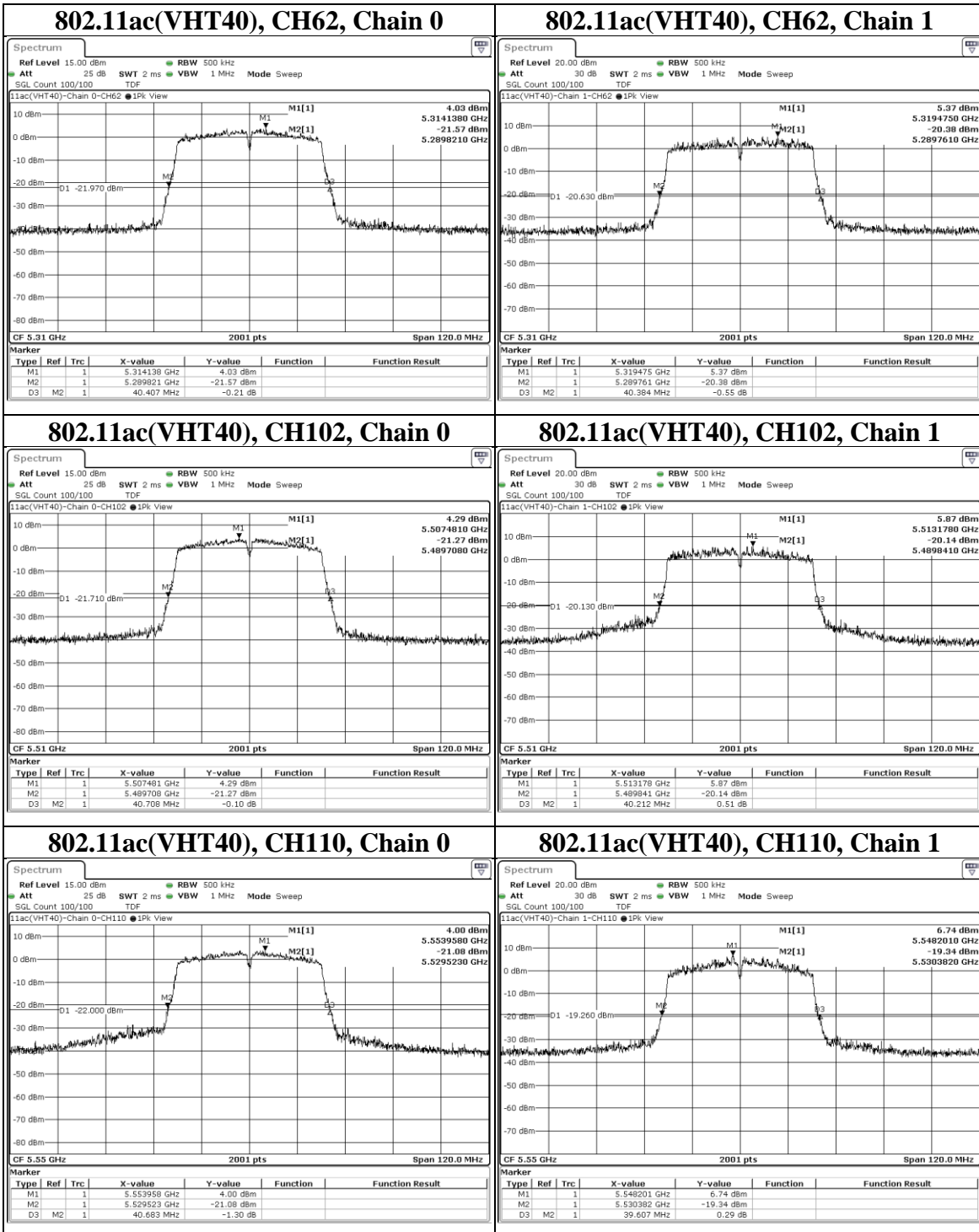

Underwriters Laboratories Taiwan Co., Ltd.

Building B and Building E, No. 372-7, Sec. 4, Zhongxing Rd., Zhudong Township, Hsinchu County, Taiwan

Telephone : +886-2-7737-3000

Facsimile (FAX) : +886-3-583-7948

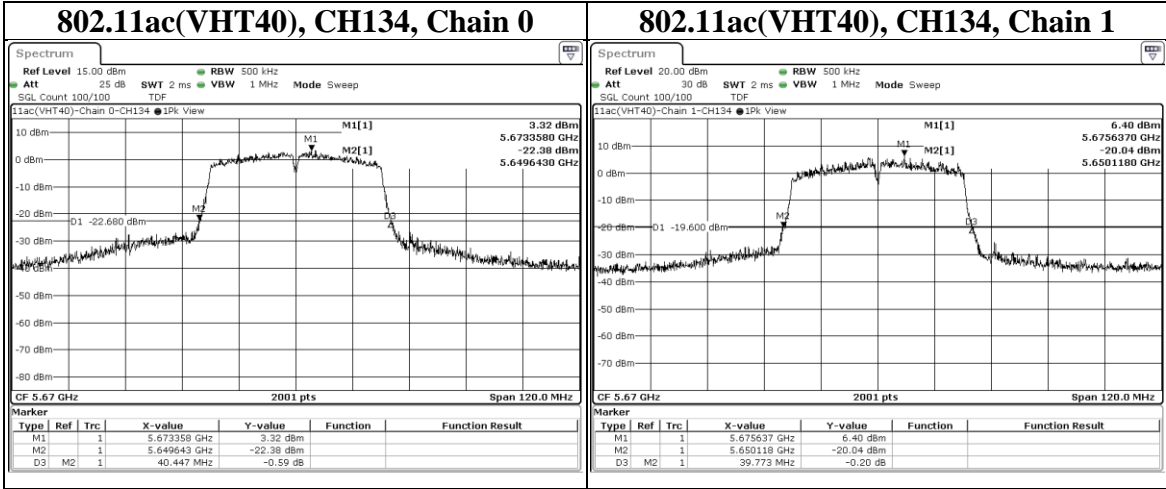

Underwriters Laboratories Taiwan Co., Ltd.

Building B and Building E, No. 372-7, Sec. 4, Zhongxing Rd., Zhudong Township, Hsinchu County, Taiwan

Telephone : +886-2-7737-3000

Facsimile (FAX) : +886-3-583-7948



Test report No. : 4790358903-US-R1-V0
Page : 40 of 154
Issued date : 2022/6/7
FCC ID : 2A4GY-LB-TABLET01

Mode	CH	Freq (MHz)	26dB BW (MHz)		Limit (MHz)	Result
			Chain 0	Chain 1		
802.11ac(VHT80)	42	5210	81.211	79.599	N/A	Pass
	58	5290	81.433	80.199	N/A	Pass
	106	5530	81.567	79.772	N/A	Pass
	122	5610	81.201	79.378	N/A	Pass

Underwriters Laboratories Taiwan Co., Ltd.

Building B and Building E, No. 372-7, Sec. 4, Zhongxing Rd., Zhudong Township, Hsinchu County, Taiwan

Telephone :+886-2-7737-3000

Facsimile (FAX) :+886-3-583-7948

Doc No: 17-EM-F0878 / 6.0

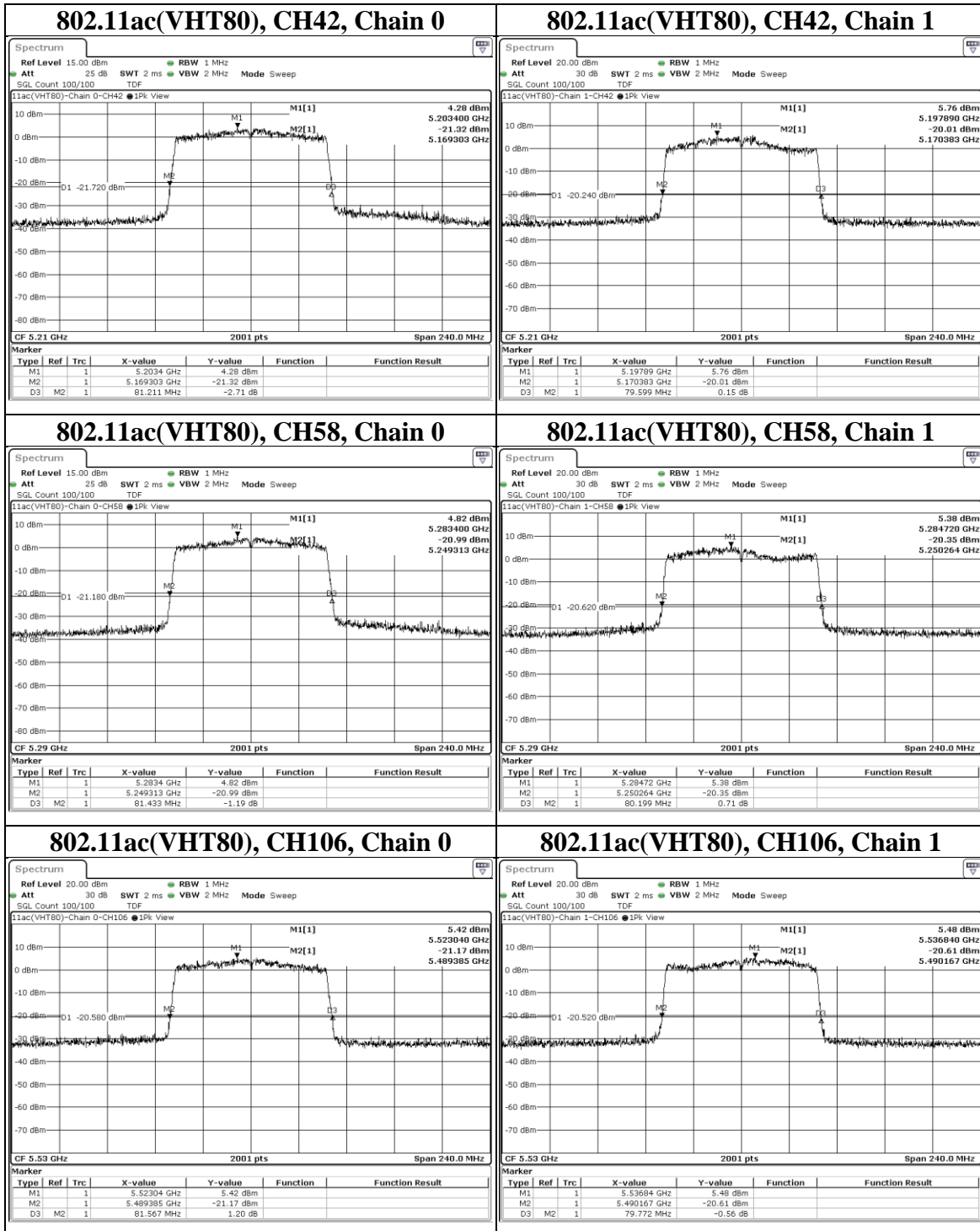

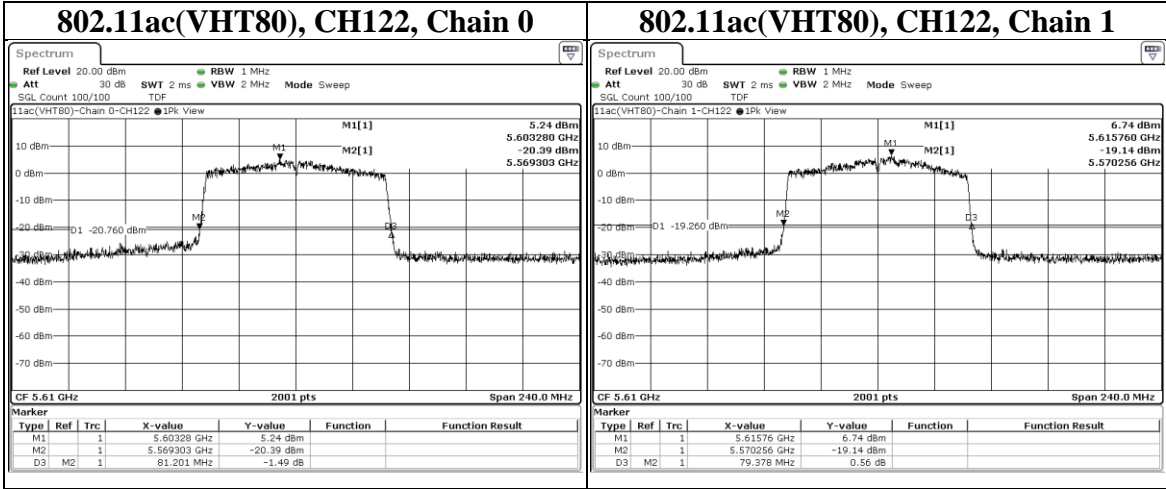

Underwriters Laboratories Taiwan Co., Ltd.

Building B and Building E, No. 372-7, Sec. 4, Zhongxing Rd., Zhudong Township, Hsinchu County, Taiwan

Telephone :+886-2-7737-3000

Facsimile (FAX) :+886-3-583-7948



9.3. Occupied Bandwidth

Test procedure

- a. Set center frequency to the nominal EUT channel center frequency.
- b. Set span = 1.5 times to 5.0 times the OBW.
- c. Set RBW = 1% to 5% of the OBW
- d. Set VBW $\geq 3 \times$ RBW
- e. Video averaging is not permitted. Where practical, a sample detection and single sweep mode shall be used. Otherwise, peak detection and max hold mode (until the trace stabilizes) shall be used.
- f. Use the 99% power bandwidth function of the instrument (if available).
- g. If the instrument does not have a 99% power bandwidth function, the trace data points are recovered and directly summed in power units. The recovered amplitude data points, beginning at the lowest frequency, are placed in a running sum until 0.5% of the total is reached; that frequency is recorded as the lower frequency. The process is repeated until 99.5% of the total is reached; that frequency is recorded as the upper frequency. The 99% occupied bandwidth is the difference between these two frequencies.

Test Setup

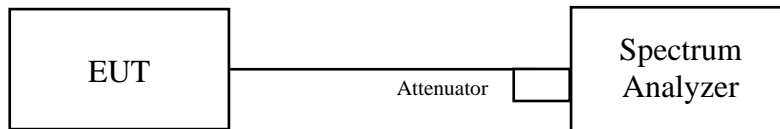

The loss between RF output port of the EUT and the input port of the Spectrum Analyzer has been taken into consideration.



Test Data

Mode	CH	Freq (MHz)	OBW (MHz)		Limit (MHz)	Result
			Chain 0	Chain 1		
802.11a	36	5180	16.963	16.726	N/A	Pass
	44	5220	17.16	16.722	N/A	Pass
	48	5240	17.192	16.774	N/A	Pass
	52	5260	17.15	16.705	N/A	Pass
	60	5300	17.062	16.81	N/A	Pass
	64	5320	17.001	16.709	N/A	Pass
	100	5500	16.964	16.842	N/A	Pass
	116	5580	16.99	16.78	N/A	Pass
	140	5700	17.086	16.748	N/A	Pass
	149	5745	17.273	16.727	N/A	Pass
	157	5785	17.513	16.811	N/A	Pass
	165	5825	17.634	16.755	N/A	Pass

Underwriters Laboratories Taiwan Co., Ltd.

Building B and Building E, No. 372-7, Sec. 4, Zhongxing Rd., Zhudong Township, Hsinchu County, Taiwan

Telephone :+886-2-7737-3000

Facsimile (FAX) :+886-3-583-7948

Doc No: 17-EM-F0878 / 6.0

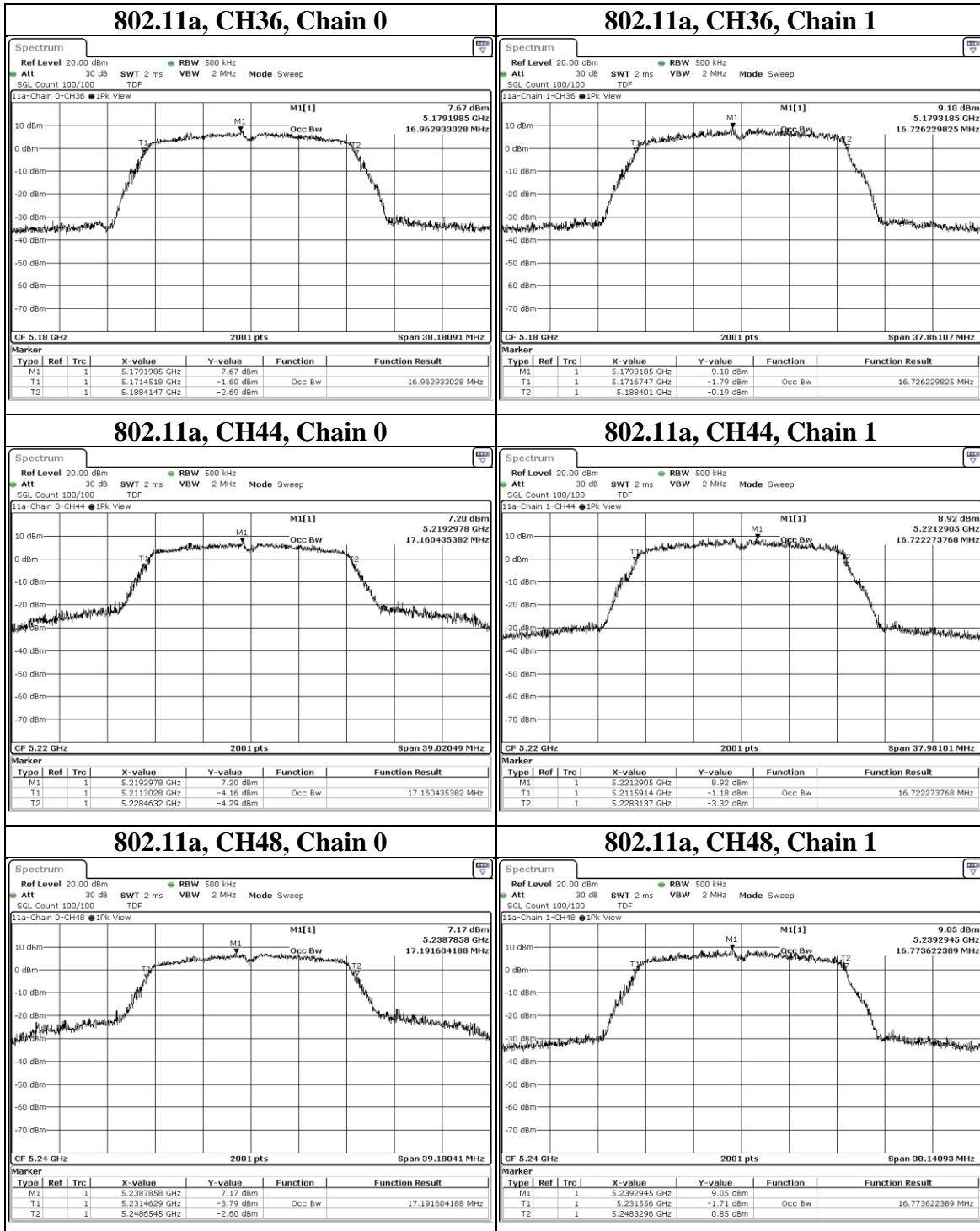

Underwriters Laboratories Taiwan Co., Ltd.

Building B and Building E, No. 372-7, Sec. 4, Zhongxing Rd., Zhudong Township, Hsinchu County, Taiwan

Telephone : +886-2-7737-3000

Facsimile (FAX) : +886-3-583-7948

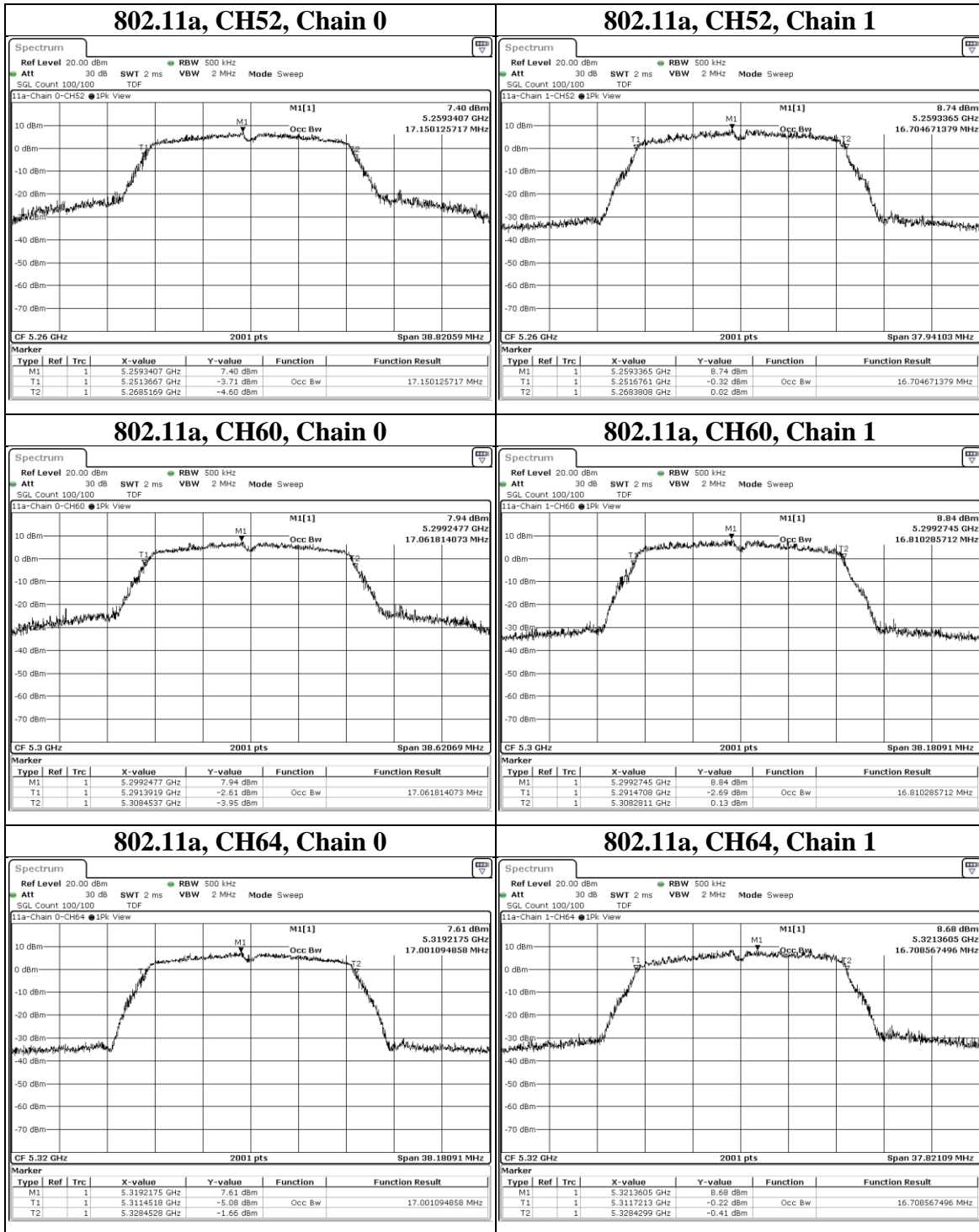

Underwriters Laboratories Taiwan Co., Ltd.

Building B and Building E, No. 372-7, Sec. 4, Zhongxing Rd., Zhudong Township, Hsinchu County, Taiwan

Telephone : +886-2-7737-3000

Facsimile (FAX) : +886-3-583-7948

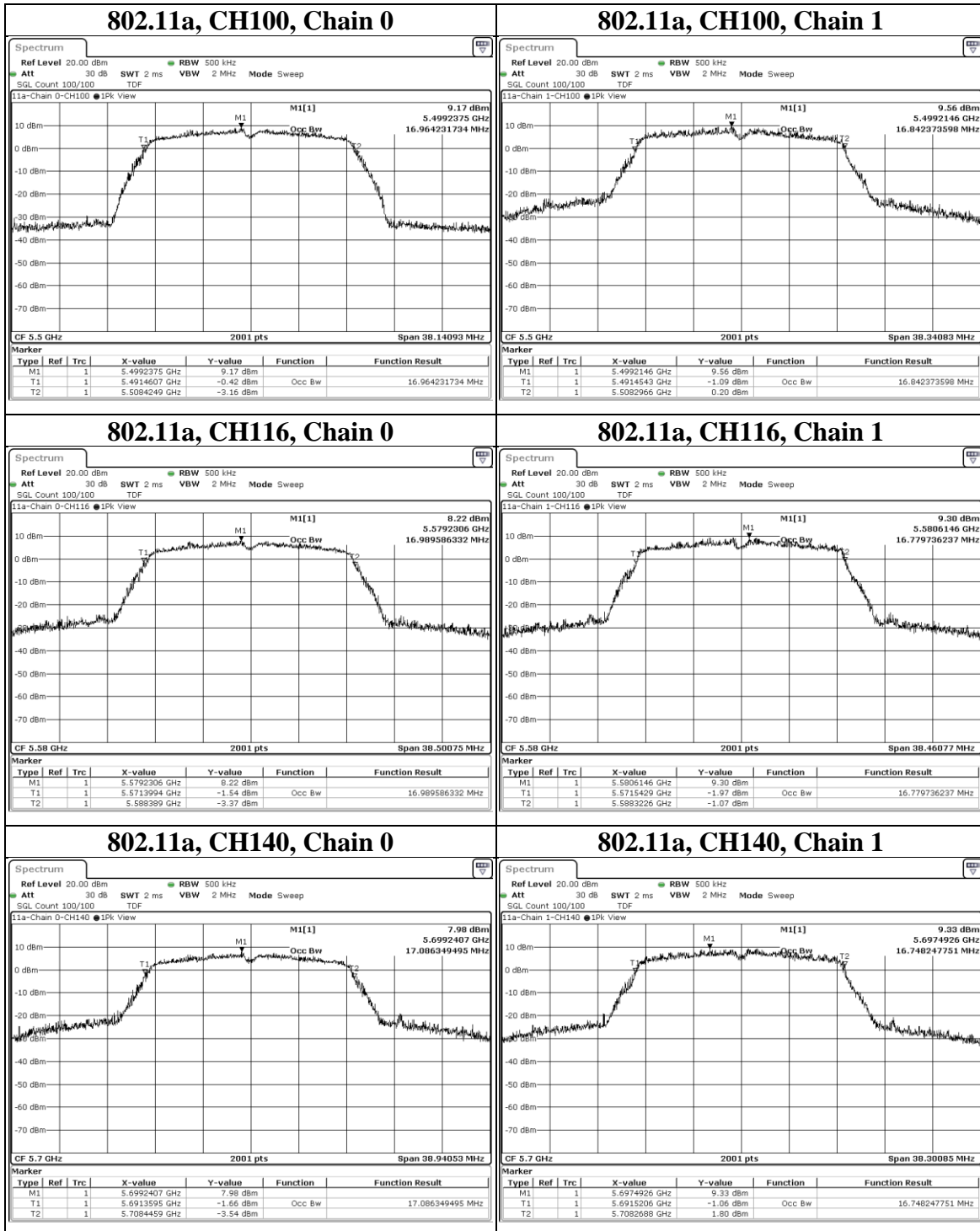

Underwriters Laboratories Taiwan Co., Ltd.

Building B and Building E, No. 372-7, Sec. 4, Zhongxing Rd., Zhudong Township, Hsinchu County, Taiwan

Telephone : +886-2-7737-3000

Facsimile (FAX) : +886-3-583-7948

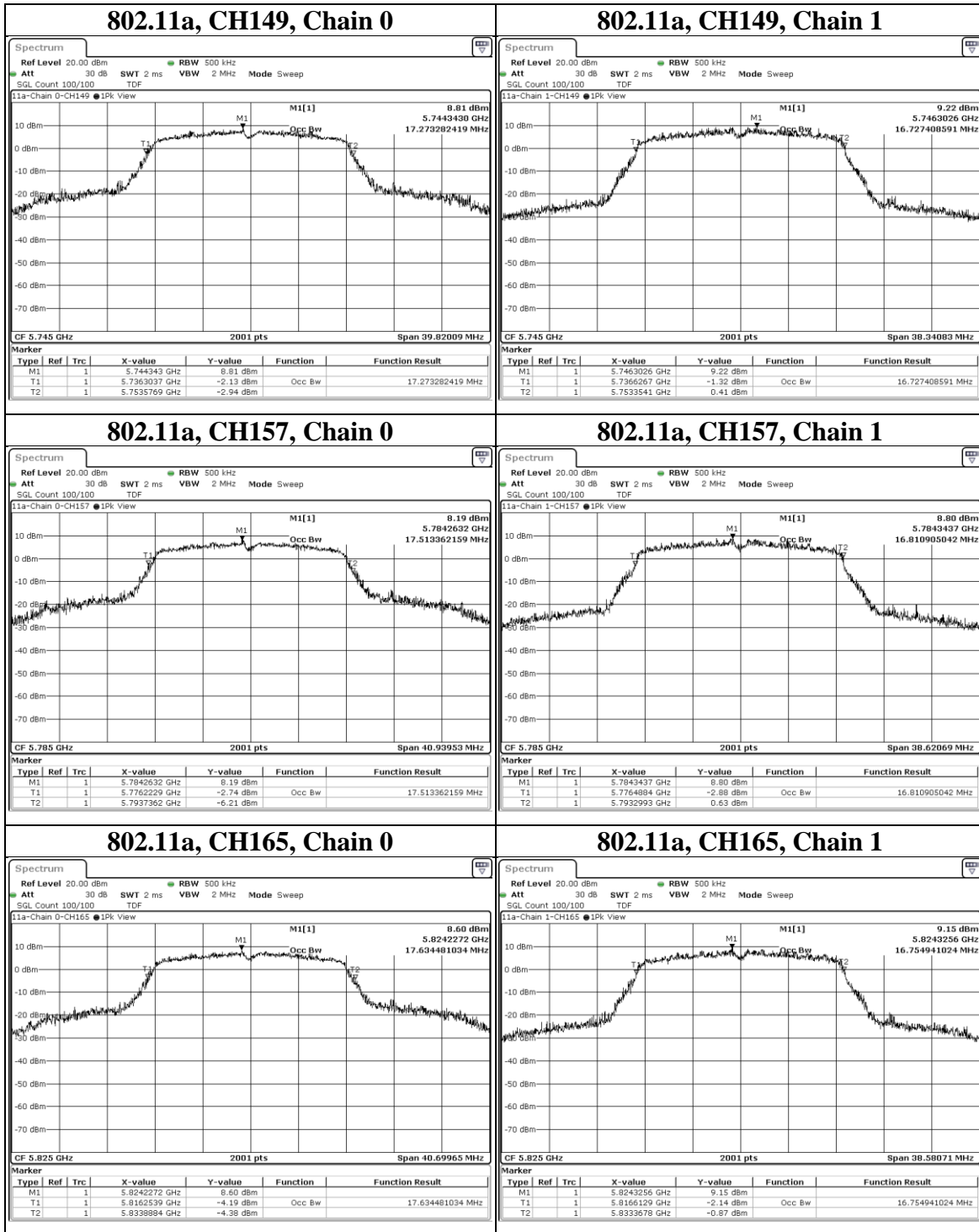



Mode	CH	Freq (MHz)	OBW (MHz)		Limit (MHz)	Result
			Chain 0	Chain 1		
802.11ac(VHT20)	36	5180	17.89	17.656	N/A	Pass
	44	5220	18	17.705	N/A	Pass
	48	5240	18.021	17.715	N/A	Pass
	52	5260	17.916	17.709	N/A	Pass
	60	5300	17.972	17.689	N/A	Pass
	64	5320	17.854	17.654	N/A	Pass
	100	5500	17.828	17.718	N/A	Pass
	116	5580	17.978	17.718	N/A	Pass
	140	5700	17.969	17.675	N/A	Pass
	149	5745	18.054	17.662	N/A	Pass
	157	5785	18.26	17.766	N/A	Pass
	165	5825	18.281	17.728	N/A	Pass

Underwriters Laboratories Taiwan Co., Ltd.

Building B and Building E, No. 372-7, Sec. 4, Zhongxing Rd., Zhudong Township, Hsinchu County, Taiwan

Telephone :+886-2-7737-3000

Facsimile (FAX) :+886-3-583-7948

Doc No: 17-EM-F0878 / 6.0

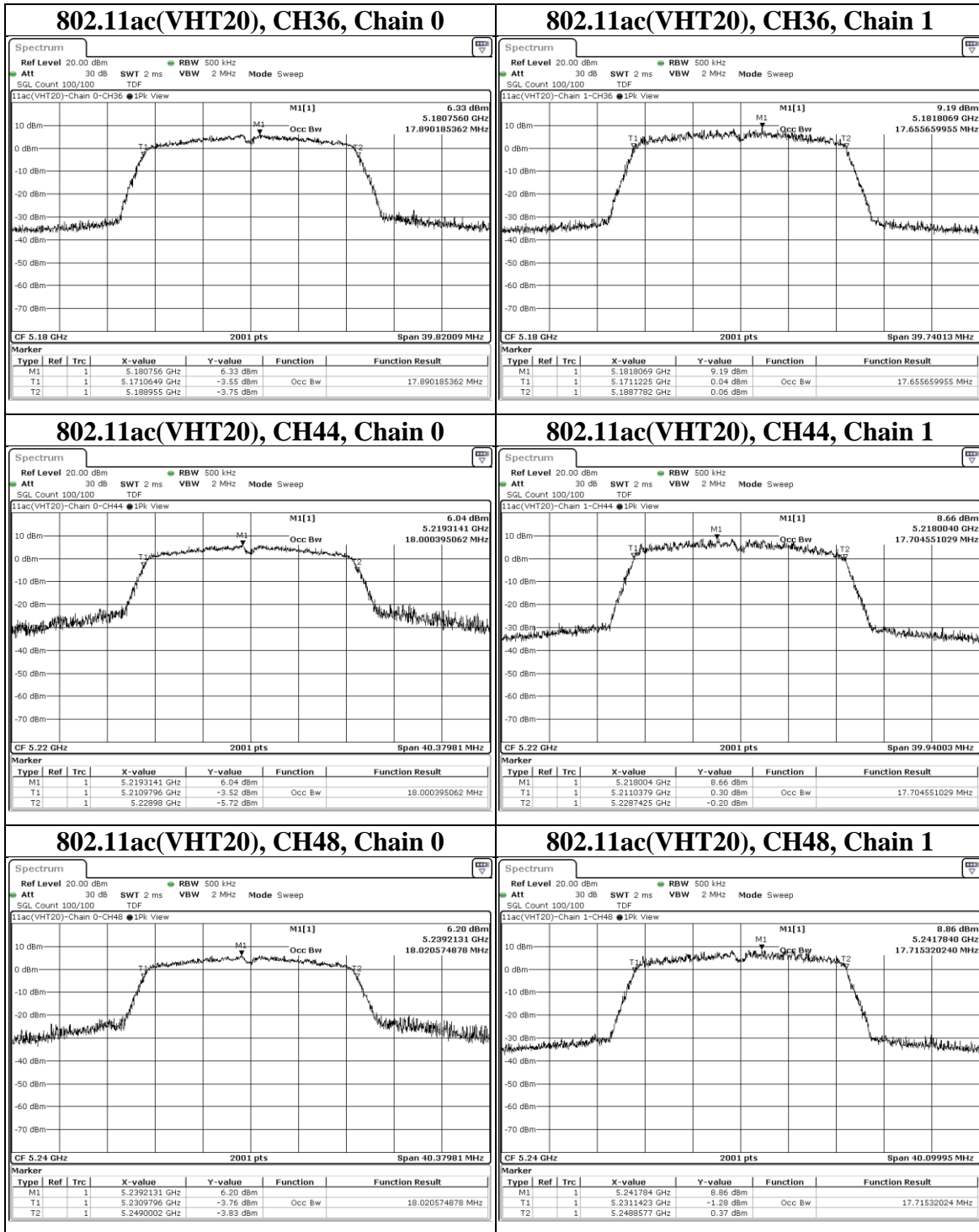

Underwriters Laboratories Taiwan Co., Ltd.

Building B and Building E, No. 372-7, Sec. 4, Zhongxing Rd., Zhudong Township, Hsinchu County, Taiwan

Telephone : +886-2-7737-3000

Facsimile (FAX) : +886-3-583-7948