

FCC and ISED Test Report

XYZ Reality Ltd

Model: Atom Controller

In accordance with FCC 47 CFR Part 15C,
ISED RSS-247 and ISED RSS-GEN
(2.4 GHz Proprietary ISM)



Add value.
Inspire trust.

Prepared for: XYZ Reality Ltd
Unit G0, G02, 338-346
Goswell Road
Angel
Clerkenwell
EC1V 7LQ
United Kingdom

FCC ID: 2A3C5-XYZ2201

IC: 28181XYZ2201

COMMERCIAL-IN-CONFIDENCE

Document 75952587-18 Issue 01

SIGNATURE

NAME	JOB TITLE	RESPONSIBLE FOR	ISSUE DATE
Steve Marshall	Senior Engineer	Authorised Signatory	11 February 2022

Signatures in this approval box have checked this document in line with the requirements of TÜV SÜD document control rules.

ENGINEERING STATEMENT

The measurements shown in this report were made in accordance with the procedures described on test pages. All reported testing was carried out on a sample equipment to demonstrate limited compliance with FCC 47 CFR Part 15C, ISED RSS-247 and ISED RSS-GEN. The sample tested was found to comply with the requirements defined in the applied rules.

RESPONSIBLE FOR	NAME	DATE	SIGNATURE
Testing	Graeme Lawler	11 February 2022	
Testing	Daniel Cameron	11 February 2022	
Testing	Paul Dickson	11 February 2022	

FCC Accreditation
90987 Octagon House, Fareham Test Laboratory

ISED Accreditation
12669A Octagon House, Fareham Test Laboratory

EXECUTIVE SUMMARY

A sample of this product was tested and found to be compliant with FCC 47 CFR Part 15C: 2020, ISED RSS-247: Issue 2 (02-2017) and ISED RSS-GEN: Issue 5 (04-2018) + A2 (02-2021) for the tests detailed in section 1.3.



DISCLAIMER AND COPYRIGHT

This non-binding report has been prepared by TÜV SÜD with all reasonable skill and care. The document is confidential to the potential Client and TÜV SÜD. No part of this document may be reproduced without the prior written approval of TÜV SÜD. © 2022 TÜV SÜD. This report relates only to the actual item/items tested.

ACCREDITATION

Our UKAS Accreditation does not cover opinions and interpretations and any expressed are outside the scope of our UKAS Accreditation. Results of tests not covered by our UKAS Accreditation Schedule are marked NUA (Not UKAS Accredited).

TÜV SÜD
is a trading name of TÜV SÜD Ltd
Registered in Scotland at East Kilbride,
Glasgow G75 0QF, United Kingdom
Registered number: SC215164

TÜV SÜD Ltd is a
TÜV SÜD Group Company

Phone: +44 (0) 1489 558100
Fax: +44 (0) 1489 558101
www.tuvsud.com/en

TÜV SÜD
Octagon House
Concorde Way
Fareham
Hampshire PO15 5RL
United Kingdom



Contents

1	Report Summary	2
1.1	Report Modification Record.....	2
1.2	Introduction.....	2
1.3	Brief Summary of Results	3
1.4	Application Form	4
1.5	Product Information	7
1.6	Deviations from the Standard.....	7
1.7	EUT Modification Record	7
1.8	Test Location	7
2	Test Details	8
2.1	Restricted Band Edges.....	8
2.2	Emission Bandwidth	12
2.3	Maximum Conducted Output Power	18
2.4	Spurious Radiated Emissions	21
2.5	Authorised Band Edges	55
2.6	Power Spectral Density	59
3	Photographs	62
3.1	Test Setup Photographs	62
4	Measurement Uncertainty	69



1 Report Summary

1.1 Report Modification Record

Alterations and additions to this report will be issued to the holders of each copy in the form of a complete document.

Issue	Description of Change	Date of Issue
1	First Issue	11-February-2022

Table 1

1.2 Introduction

Applicant	XYZ Reality Ltd
Manufacturer	XYZ Reality Ltd
Model Number(s)	Atom Controller
Serial Number(s)	Not serialised (Storix-ID 599374-119) and Not serialised (Storix-ID 599374-98)
Hardware Version(s)	Not Applicable
Software Version(s)	Not Applicable
Number of Samples Tested	2
Test Specification/Issue/Date	FCC 47 CFR Part 15C: 2020, ISED RSS-247: Issue 2 (02-2017) ISED RSS-GEN: Issue 5 (04-2018) + A2 (02-2021)
Order Number	XYZ0179
Date	21-June-2021
Date of Receipt of EUT	06-September-2021
Start of Test	08-October-2021
Finish of Test	16-November-2021
Name of Engineer(s)	Graeme Lawler, Daniel Cameron and Paul Dickson
Related Document(s)	ANSI C63.10 (2013)



1.3 Brief Summary of Results

A brief summary of the tests carried out in accordance with FCC 47 CFR Part 15C, ISED RSS-247 and ISED RSS-GEN is shown below.

Section	Specification Clause			Test Description	Result	Comments/Base Standard
	Part 15C	RSS-247	RSS-GEN			
Configuration and Mode: 2.4 GHz proprietary device						
-	15.203	-	-	Antenna Requirement	N/T	The device complies with the provisions of this section, as it uses permanently attached integral antennas.
2.1	15.205	-	8.10	Restricted Band Edges	Pass	
2.2	15.247 (a)(2)	5.2	6.7	Emission Bandwidth	Pass	
2.3	15.247 (b)	5.4	6.12	Maximum Conducted Output Power	Pass	
2.4	15.247 (d) and 15.209	3.3 and 5.5	6.13 and 8.9	Spurious Radiated Emissions	Pass	
2.5	15.247 (d)	5.5	-	Authorised Band Edges	Pass	
2.6	15.247 (e)	5.2	6.12	Power Spectral Density	Pass	

Table 2



1.4 Application Form

Equipment Description

Technical Description: <i>(Please provide a brief description of the intended use of the equipment including the technologies the product supports)</i>	Protective hard Hat with integrated eye protection and augmented reality	
Manufacturer:	XYZ Reality Ltd	
Model:	Atom Controller	
Part Number:	XYZ-22-01	
Hardware Version:	N/A	
Software Version:	N/A	
FCC ID of the product under test – see guidance here	2A3C5-XYZ2201	
IC ID of the product under test – see guidance here	28181XYZ2201	

Table 3

Intentional Radiators

Technology	Proprietary ISM 2.4GHz					
Frequency Range (MHz to MHz)	2402-2480					
Conducted Declared Output Power (dBm)	0					
Antenna Gain (dBi)	1					
Supported Bandwidth(s) (MHz) (e.g 1 MHz, 20 MHz, 40 MHz)	1 MHz					
Modulation Scheme(s) (e.g GFSK, QPSK etc)	GFSK / DQPSK					
ITU Emission Designator (see guidance here) (not mandatory for Part 15 devices)	1M00F1D					
Bottom Frequency (MHz)	2402					
Middle Frequency (MHz)	2440					
Top Frequency (MHz)	2480					

Table 4



Un-intentional Radiators

Highest frequency generated or used in the device or on which the device operates or tunes	
Lowest frequency generated or used in the device or on which the device operates or tunes	
Class A Digital Device (Use in commercial, industrial or business environment) <input type="checkbox"/>	
Class B Digital Device (Use in residential environment only) <input checked="" type="checkbox"/>	

Table 5

AC Power Source

AC supply frequency:		Hz
Voltage		V
Max current:		A
Single Phase <input type="checkbox"/> Three Phase <input type="checkbox"/>		

Table 6

DC Power Source

Nominal voltage:		V
Extreme upper voltage:		V
Extreme lower voltage:		V
Max current:		A

Table 7

Battery Power Source

Voltage:	7.4	V
End-point voltage:		V (Point at which the battery will terminate)
Alkaline <input type="checkbox"/> Leclanche <input type="checkbox"/> Lithium <input type="checkbox"/> Nickel Cadmium <input type="checkbox"/> Lead Acid* <input type="checkbox"/> *(Vehicle regulated)		
Other <input checked="" type="checkbox"/>	Please detail:	Li Ion

Table 8

Charging

Can the EUT transmit whilst being charged	Yes <input type="checkbox"/> No <input checked="" type="checkbox"/>
-------------------------------------------	---------------------------------------------------------------------

Table 9

Temperature

Minimum temperature:	0	°C
Maximum temperature:	40	°C

Table 10



Cable Loss

Adapter Cable Loss (Conducted sample)	1.3	dB
------------------------------------------	-----	----

Table 11

Antenna Characteristics

Antenna connector <input checked="" type="checkbox"/>			State impedance	50	Ohm
Temporary antenna connector <input type="checkbox"/>			State impedance		Ohm
Integral antenna <input checked="" type="checkbox"/>	Type:	Chip	Gain	1	dBi
External antenna <input type="checkbox"/>	Type:		Gain		dBi
For external antenna only: Standard Antenna Jack <input type="checkbox"/> If yes, describe how user is prohibited from changing antenna (if not professional installed): Equipment is only ever professionally installed <input type="checkbox"/> Non-standard Antenna Jack <input type="checkbox"/>					

Table 12

Ancillaries (if applicable)

Manufacturer:		Part Number:	
Model:		Country of Origin:	

Table 13

I hereby declare that the information supplied is correct and complete.

Name: Dave Williams
 Position held: Director of Engineering, DitroniX Ltd
 Date: 04 November 2021



1.5 Product Information

1.5.1 Technical Description

The EUT is a Handheld device for interacting with Atom Hard Hat and Atom Tracking Beacons.

1.6 Deviations from the Standard

No deviations from the applicable test standard were made during testing.

1.7 EUT Modification Record

The table below details modifications made to the EUT during the test programme.

The modifications incorporated during each test are recorded on the appropriate test pages.

Modification State	Description of Modification still fitted to EUT	Modification Fitted By	Date Modification Fitted
Model: Atom Controller, Serial Number: Not serialised (Storix-ID 599374-98)			
0	As supplied by the customer	Not Applicable	Not Applicable
Model: Atom Controller, Serial Number: Not serialised (Storix-ID 599374-119)			
0	As supplied by the customer	Not Applicable	Not Applicable

Table 14

1.8 Test Location

TÜV SÜD conducted the following tests at our Fareham Test Laboratory.

Test Name	Name of Engineer(s)	Accreditation
Configuration and Mode: 2.4 GHz proprietary device		
Restricted Band Edges	Graeme Lawler	UKAS
Emission Bandwidth	Daniel Cameron	UKAS
Maximum Conducted Output Power	Daniel Cameron	UKAS
Spurious Radiated Emissions	Paul Dickson and Graeme Lawler	UKAS
Authorised Band Edges	Graeme Lawler	UKAS
Power Spectral Density	Daniel Cameron	UKAS

Table 15

Office Address:

TÜV SÜD
 Octagon House
 Concorde Way
 Fareham
 Hampshire
 PO15 5RL
 United Kingdom



2 Test Details

2.1 Restricted Band Edges

2.1.1 Specification Reference

FCC 47 CFR Part 15C, Clause 15.205
ISED RSS-GEN, Clause 8.10

2.1.2 Equipment Under Test and Modification State

Atom Controller, S/N: Not serialised (Storix-ID 599374-98) - Modification State 0

2.1.3 Date of Test

26-October-2021

2.1.4 Test Method

This test was performed in accordance with ANSI C63.10, clause 6.10.5.

Plots for average measurements were taken in accordance with ANSI C63.10, clause 4.1.4.2.3. These are shown for information purposes and were used to determine the worst-case measurement point. Final average measurements were then taken in accordance with ANSI C63.10, clause 4.1.4.2.2 to obtain the measurement result recorded in the test results tables.

The following conversion can be applied to convert from dB μ V/m to μ V/m:
 $10^{(\text{Field Strength in dB}\mu\text{V/m}/20)}$.

2.1.5 Environmental Conditions

Ambient Temperature	26.2 °C
Relative Humidity	41.7 %



2.1.6 Test Results

2.4 GHz proprietary device

Mode	Frequency (MHz)	Band Edge Frequency (MHz)	Peak Level (dBµV/m)	Average Level (dBµV/m)
Static	2402	2390	52.30	35.10
Static	2480	2483.5	53.69	35.19

Table 16

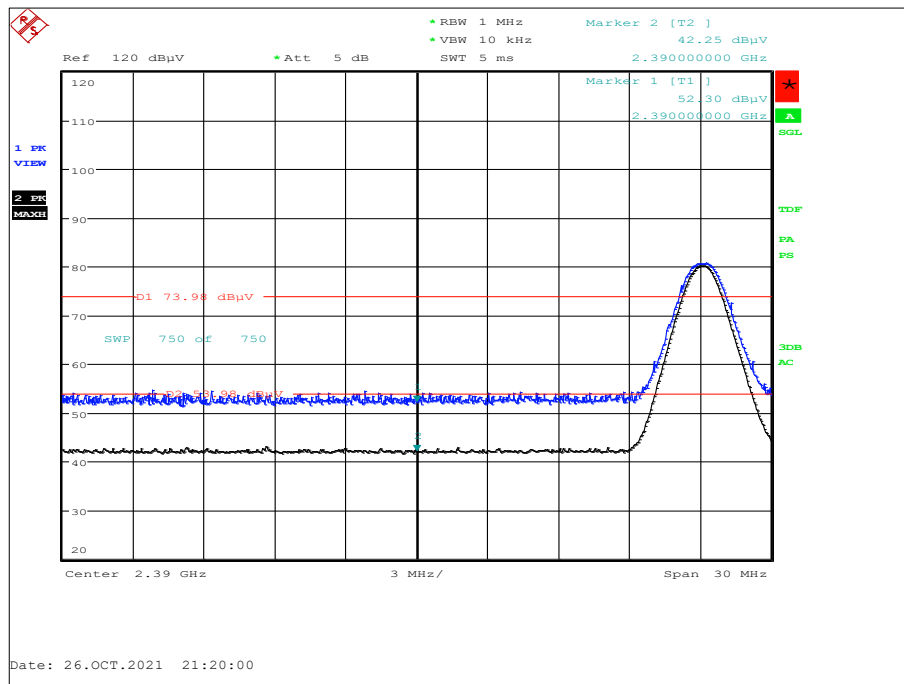

Figure 1 - 2402 MHz - Band Edge Frequency 2390 MHz

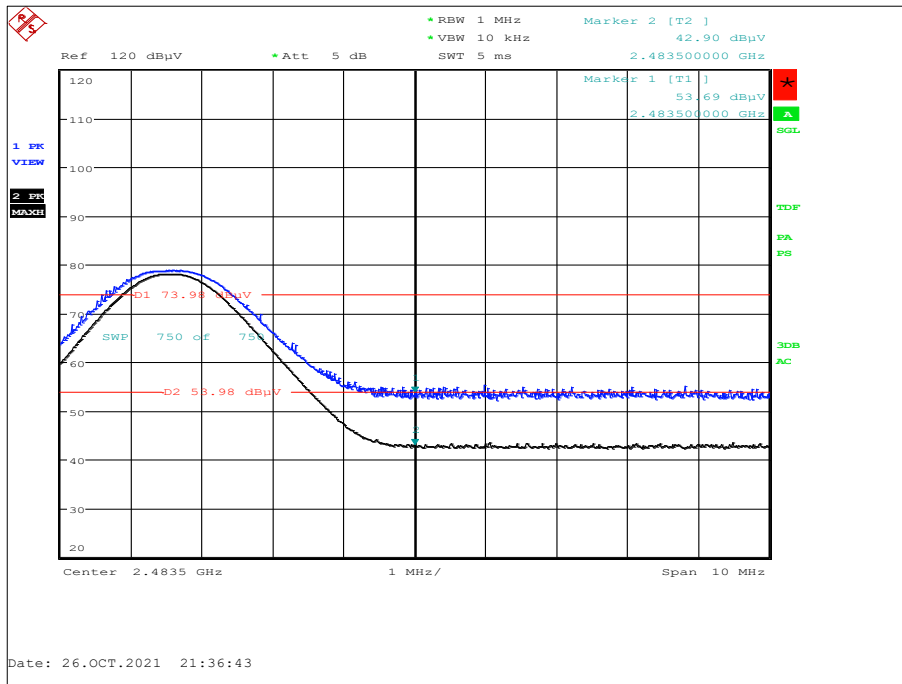

Figure 2 - 2480 MHz - Band Edge Frequency 2483.5 MHz

FCC 47 CFR Part 15, Limit Clause 15.209

Frequency (MHz)	Field Strength ($\mu\text{V}/\text{m}$ at 3 m)
30 to 88	100
88 to 216	150
216 to 960	200
Above 960	500

Table 17

ISED RSS-GEN, Limit Clause 8.9

Frequency (MHz)	Field Strength ($\mu\text{V}/\text{m}$ at 3 m)
30 to 88	100
88 to 216	150
216 to 960	200
Above 960*	500

Table 18

*Unless otherwise specified, for all frequencies greater than 1 GHz, the radiated emission limits for licence-exempt radio apparatus stated in applicable RSSs (including RSS-Gen) are based on measurements using a linear average detector function having a minimum resolution bandwidth of 1 MHz. If an average limit is specified for the EUT, then the peak emission shall also be measured with instrumentation properly adjusted for such factors as pulse desensitization to ensure the peak emission is less than 20 dB above the average limit.



2.1.7 Test Location and Test Equipment Used

This test was carried out in EMC Chamber 12.

Instrument	Manufacturer	Type No	TE No	Calibration Period (months)	Calibration Expires
Test Receiver	Rohde & Schwarz	ESU40	3506	12	18-Mar-2022
Cable (K-Type to K-Type, 2 m)	Scott Cables	KPS-1501-2000-KPS	4526	6	06-Mar-2022
EmX Emissions Software	TUV SUD	V2.1.11	5125	-	Software
Cable (N-Type to N-Type, 8 m)	Teledyne	PR90-088-8MTR	5450	6	08-Mar-2022
Thermo-Hygro-Barometer	PCE Instruments	PCE-THB-40	5481	12	31-Mar-2022
Antenna (DRG, 1 GHz to 10 GHz)	Schwarzbeck	BBHA 9120 B	5611	12	15-Oct-2022
Turntable & Mast Controller	Maturo Gmbh	NCD/498/2799.01	5612	-	TU
Tilt Antenna Mast	Maturo Gmbh	TAM 4.0-P	5613	-	TU
Turntable	Maturo Gmbh	Turntable 1.5 SI-2t	5614	-	TU
Screened Room (12)	MVG	EMC-3	5621	36	11-Aug-2023

Table 19

TU - Traceability Unscheduled



2.2 Emission Bandwidth

2.2.1 Specification Reference

FCC 47 CFR Part 15C, Clause 15.247 (a)(2)
ISED RSS-247, Clause 5.2
ISED RSS-GEN, Clause 6.7

2.2.2 Equipment Under Test and Modification State

Atom Controller, S/N: Not serialised (Storix-ID 599374-119) - Modification State 0

2.2.3 Date of Test

08-October-2021 to 16-November-2021

2.2.4 Test Method

This test was performed in accordance with ANSI C63.10, clause 11.8.1 for 6 dB bandwidth and 6.9.3 for 99% occupied bandwidth measurements.

2.2.5 Environmental Conditions

Ambient Temperature	20.8-21.8 °C
Relative Humidity	38.8-56.5 %



2.2.6 Test Results

2.4 GHz proprietary device

Test Configuration			
Frequency Range:	2400-2483.5 MHz	Band:	2.4 GHz
Limit Clause(s):	15.247 (a)(2) RSS-247 5.2 a)	Test Method(s):	C63.10 6.9.3 C63.10 11.8.1
Additional Reference(s):	-		

DUT Configuration			
Mode:	Proprietary ISM	Duty Cycle (%):	-
Data Rate:	-	DCCF (dB):	-
Antenna Configuration:	SISO	Peak Antenna Gain (dBi):	-
Active Port(s):	1	Active Chain(s):	0

Test Frequency (MHz)	6 dB Bandwidth (MHz)					Limit (kHz)
	A	B	C	D	Minimum	
2402	0.516	-	-	-	0.516	≥500.0
2442	0.508	-	-	-	0.508	≥500.0
2480	0.500	-	-	-	0.500	≥500.0

Table 20 - 6 dB Bandwidth Results

Test Frequency (MHz)	99% Bandwidth (MHz)					Limit (kHz)
	A	B	C	D	Minimum	
2402	0.840	-	-	-	0.840	-
2442	0.896	-	-	-	0.896	-
2480	0.860	-	-	-	0.860	-

Table 21 - 99% Bandwidth Results

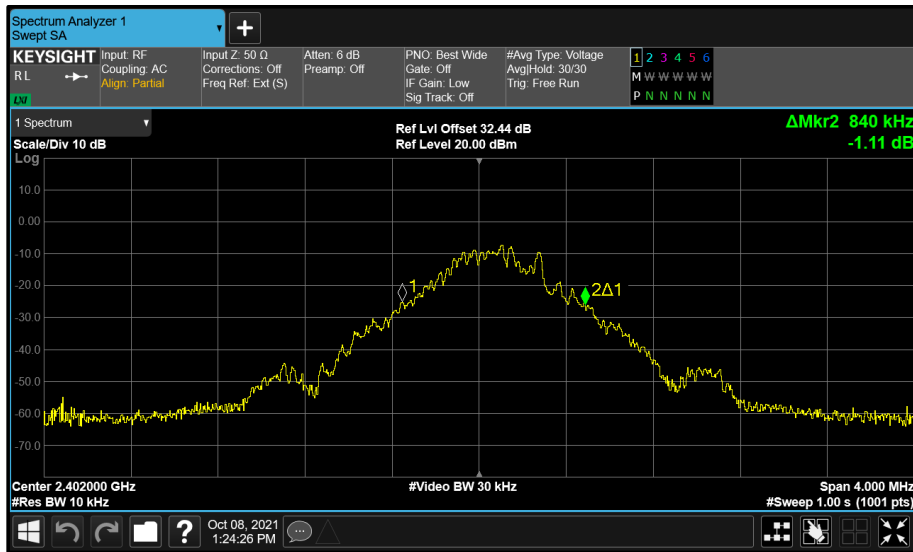

Figure 3 - A (A) 2402 MHz 99% Bandwidth

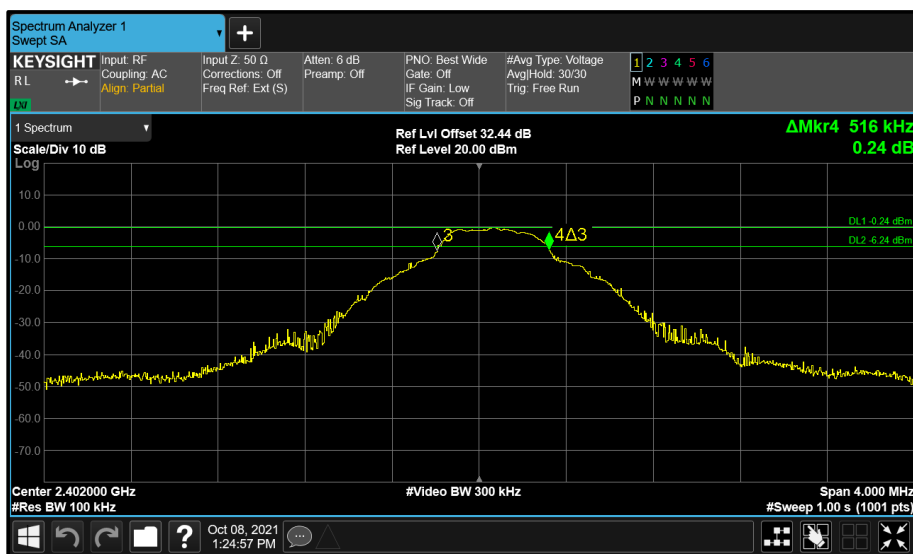

Figure 4 - A (A) 2402 MHz 6 dB Bandwidth

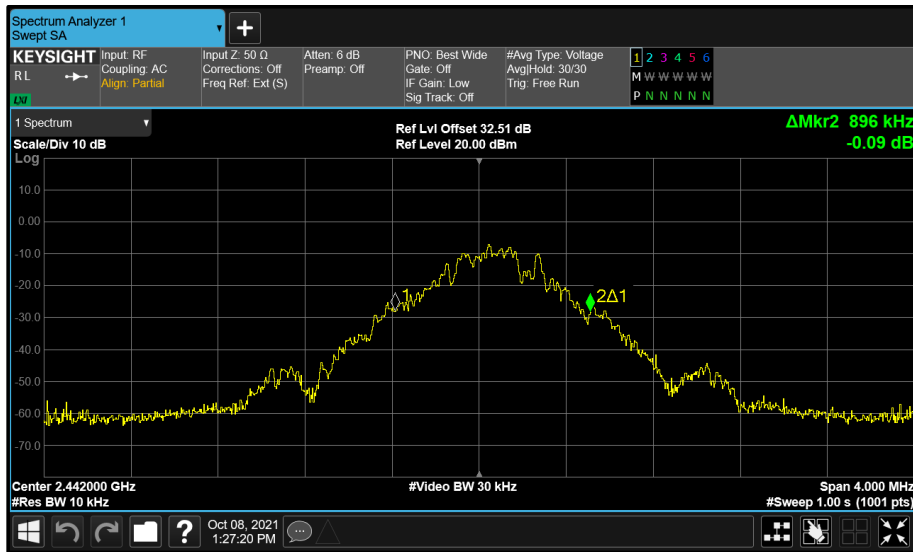

Figure 5 - A (A) 2442 MHz 99% Bandwidth

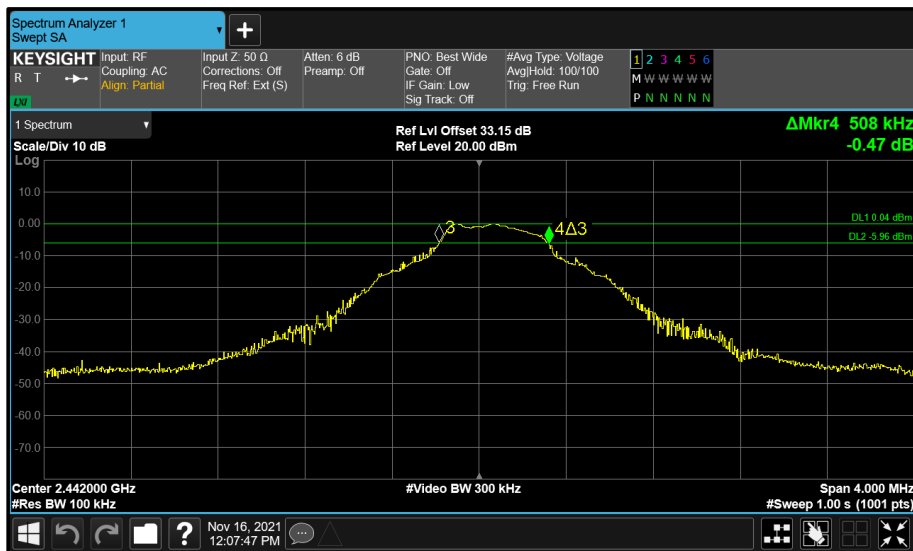

Figure 6 - A (A) 2442 MHz 6 dB Bandwidth

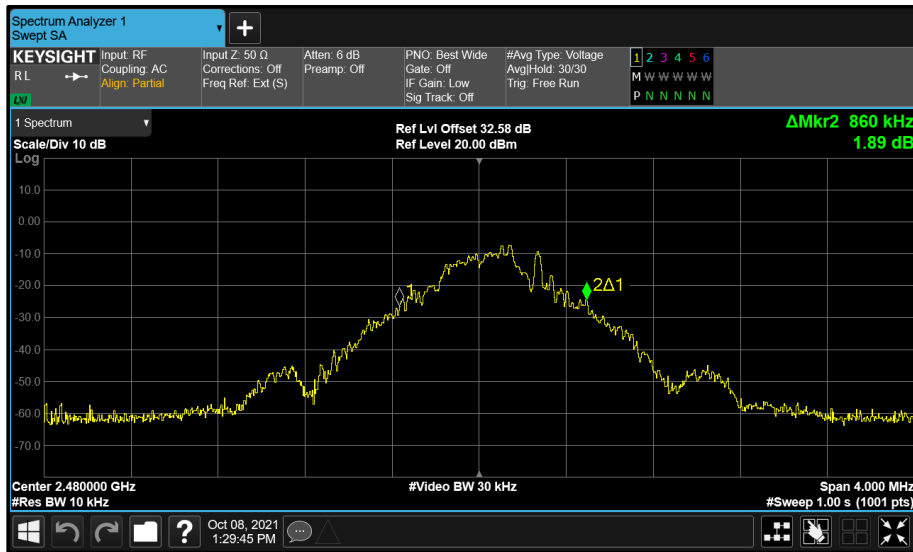

Figure 7 - A (A) 2480 MHz 99% Bandwidth

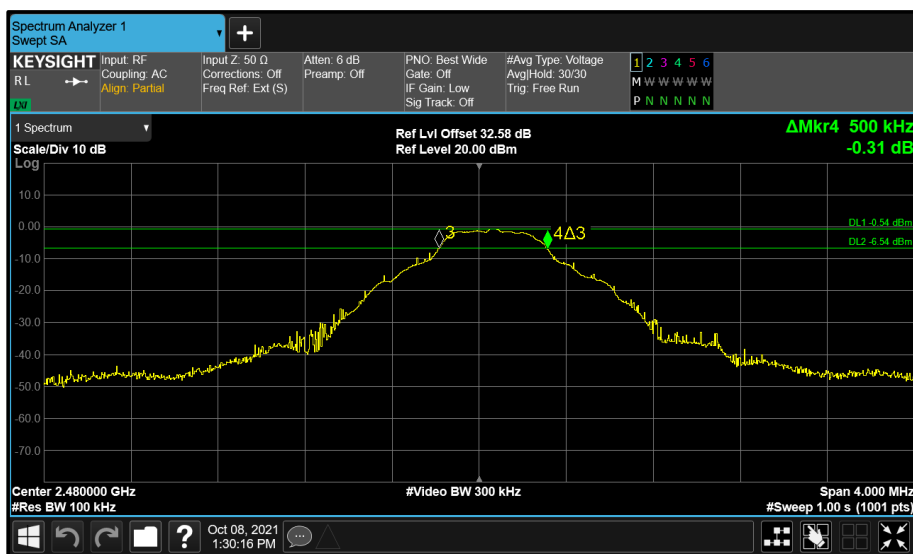

Figure 8 - A (A) 2480 MHz 6 dB Bandwidth

FCC 47 CFR Part 15, Limit Clause 15.247(a)(2) and ISED RSS-247, Clause 5.2(a)

The minimum 6 dB Bandwidth shall be at least 500 kHz.



2.2.7 Test Location and Test Equipment Used

This test was carried out in RF Laboratory 1.

Instrument	Manufacturer	Type No	TE No	Calibration Period (months)	Calibration Expires
Rubidium Standard	Rohde & Schwarz	XSRM	1316	6	03-Dec-2021
Hygrometer	Rotronic	I-1000	3220	12	16-Oct-2021
Frequency Standard	Spectracom	SecureSync 1200-0408-0601	4393	6	03-Dec-2021
Climatic Chamber	Aralab	FitoTerm 300E45	4823	12	12-Apr-2022
Hygropalm Hygrometer	Rotronic	HP21	5264	12	12-Jul-2022
MXA Signal Analyser	Keysight Technologies	N9020B	5528	24	04-Mar-2022
Signal Commissioning Unit	TUV SUD	SCU001	5546	12	16-Apr-2022

Table 22



2.3 Maximum Conducted Output Power

2.3.1 Specification Reference

FCC 47 CFR Part 15C, Clause 15.247 (b)
ISED RSS-247, Clause 5.4
ISED RSS-GEN, Clause 6.12

2.3.2 Equipment Under Test and Modification State

Atom Controller, S/N: Not serialised (Storix-ID 599374-119) - Modification State 0

2.3.3 Date of Test

08-October-2021

2.3.4 Test Method

The test was performed in accordance with ANSI C63.10, clause 11.9.2.3.2.

2.3.5 Environmental Conditions

Ambient Temperature	20.8 °C
Relative Humidity	56.5 %



2.3.6 Test Results

2.4 GHz proprietary device

Test Configuration			
Frequency Range:	2400-2483.5 MHz	Band:	2.4 GHz
Limit Clause(s):	15.247 (b)(3) RSS-247 5.4 d)	Test Method(s):	C63.10 11.9.2.3.2
Additional Reference(s):	-		

DUT Configuration			
Mode:	Proprietary ISM	Duty Cycle (%):	23.2
Data Rate:	-	DCCF (dB):	-
Antenna Configuration:	SISO	Peak Antenna Gain (dBi):	1.00
Active Port(s):	1	Active Chain(s):	0

Test Frequency (MHz)	Maximum Conducted Output Power (dBm)					Limit (dBm)	Margin (dB)
	A	B	C	D	Σ		
2402	-0.27	-	-	-	-	30.00	-30.27
2442	-0.52	-	-	-	-	30.00	-30.52
2480	-0.77	-	-	-	-	30.00	-30.77

Table 23 - FCC Maximum Conducted (average) Output Power Results

Test Frequency (MHz)	Maximum Conducted Output Power (dBm)					Limit (dBm)	Margin (dB)	EIRP (dBm)	EIRP Limit (dBm)	EIRP Margin (dB)
	A	B	C	D	Σ					
2402	-0.27	-	-	-	-	30.00	-30.27	0.73	36.00	-35.27
2442	-0.52	-	-	-	-	30.00	-30.52	0.48	36.00	-35.52
2480	-0.77	-	-	-	-	30.00	-30.77	0.23	36.00	-35.77

Table 24 - ISED Maximum Conducted (average) Output Power Results

FCC 47 CFR Part 15, Limit Clause 15.247 (b)(3)

For systems using digital modulation in the 902–928 MHz, 2400–2483.5 MHz, and 5725–5850 MHz bands: 1 Watt.

ISED RSS-247, Limit Clause 5.4 (b)

For DTSS employing digital modulation techniques operating in the bands 902-928 MHz and 2400-2483.5 MHz, the maximum peak conducted output power shall not exceed 1 W. The e.i.r.p. shall not exceed 4 W, except as provided in section 5.4(e) of the specification.



2.3.7 Test Location and Test Equipment Used

This test was carried out in RF Laboratory 1.

Instrument	Manufacturer	Type No	TE No	Calibration Period (months)	Calibration Expires
Rubidium Standard	Rohde & Schwarz	XSRM	1316	6	03-Dec-2021
Hygrometer	Rotronic	I-1000	3220	12	16-Oct-2021
Frequency Standard	Spectracom	SecureSync 1200-0408-0601	4393	6	03-Dec-2021
Climatic Chamber	Aralab	FitoTerm 300E45	4823	12	12-Apr-2022
USB Power Sensor	Boonton	RTP5006	5184	12	19-Apr-2022
Signal Commissioning Unit	TUV SUD	SCU001	5546	12	16-Apr-2022

Table 25



2.4 Spurious Radiated Emissions

2.4.1 Specification Reference

FCC 47 CFR Part 15C, Clause 15.247 (d) and 15.209
ISED RSS-247, Clause 3.3 and 5.5
ISED RSS-GEN, Clause 6.13 and 8.9

2.4.2 Equipment Under Test and Modification State

Atom Controller, S/N: Not serialised (Storix-ID 599374-98) - Modification State 0

2.4.3 Date of Test

26-October-2021 to 29-October-2021

2.4.4 Test Method

This test was performed in accordance with ANSI C63.10, clause 6.3, 6.5 and 6.6.

The EUT was placed on the non-conducting platform in a manner typical of a normal installation. For an EUT which could reasonable be used in multiple planes, pre-scans were performed with the EUT orientated in X, Y and Z planes with reference to the ground plane.

For frequencies > 1 GHz, plots for average measurements were taken in accordance with ANSI C63.10, clause 4.1.4.2.3 to characterize the EUT. Where emissions were detected, final average measurements were taken in accordance with ANSI C63.10, clause 4.1.4.2.2.

The plots shown are the characterisation of the EUT. The limits on the plots represent the most stringent case for restricted bands, (74/54 dBuV/m) when compared to 20 dBc outside restricted bands. The limits shown have been used as a threshold to determine where further measurements are necessary. Where results are within 10 dB of the limits shown on the plots, further investigation was carried out and reported in results tables.

The following conversion can be applied to convert from dBµV/m to µV/m:
 $10^{(\text{Field Strength in dB}\mu\text{V}/\text{m}/20)}$.

At a measurement distance of 1 meter the limit line was increased by $20 \cdot \text{LOG}(3/1) = 9.54$ dB.

Where formal measurements have been necessary, the results have been presented in the emissions table.

2.4.5 Example Test Setup Diagram

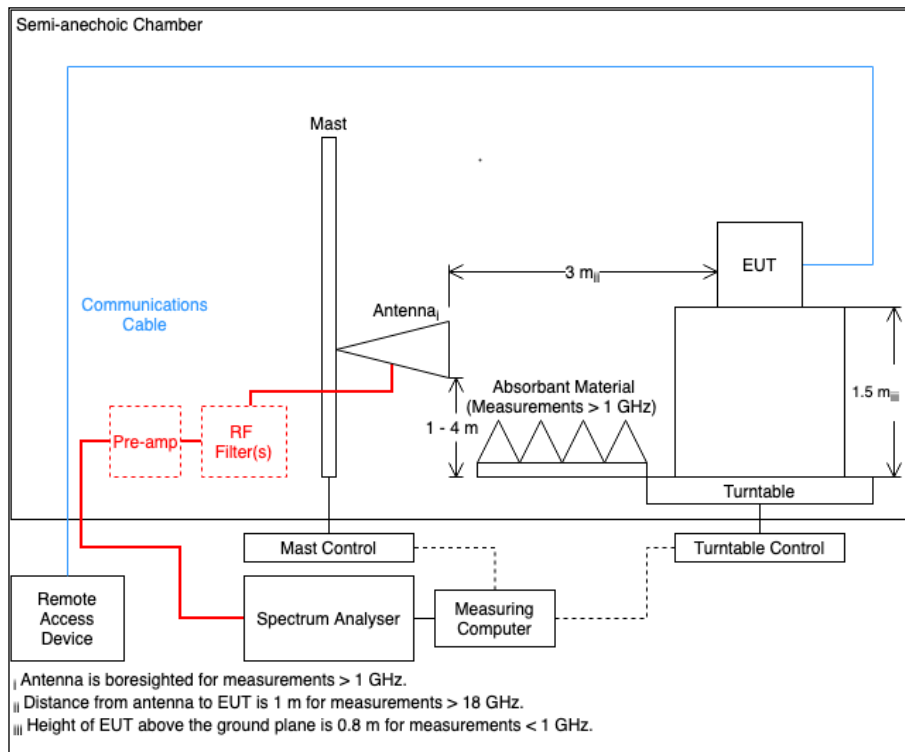

Figure 9

2.4.6 Environmental Conditions

Ambient Temperature	21.4 - 26.2 °C
Relative Humidity	39.5 - 52.0 %



2.4.7 Test Results

2.4 GHz proprietary device

Frequency (MHz)	Level (dBuV/m)	Limit (dBuV/m)	Margin (dB)	Detector	Angle (°)	Height (cm)	Polarisation
172.626	20.4	43.5	-23.1	Q-Peak	360	100	Vertical

Table 26 - Proprietary - X, 2402 MHz, 30 MHz to 25 GHz

No other emissions found within 10 dB of the limit.

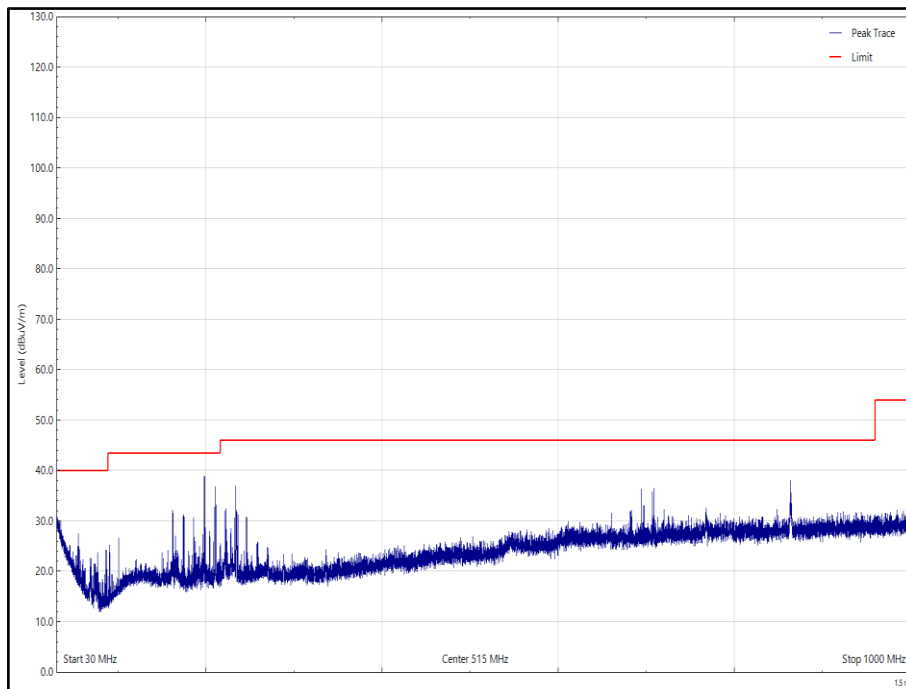

Figure 10 - Proprietary - X, 2402 MHz, 30 MHz to 1 GHz, Horizontal (Peak)

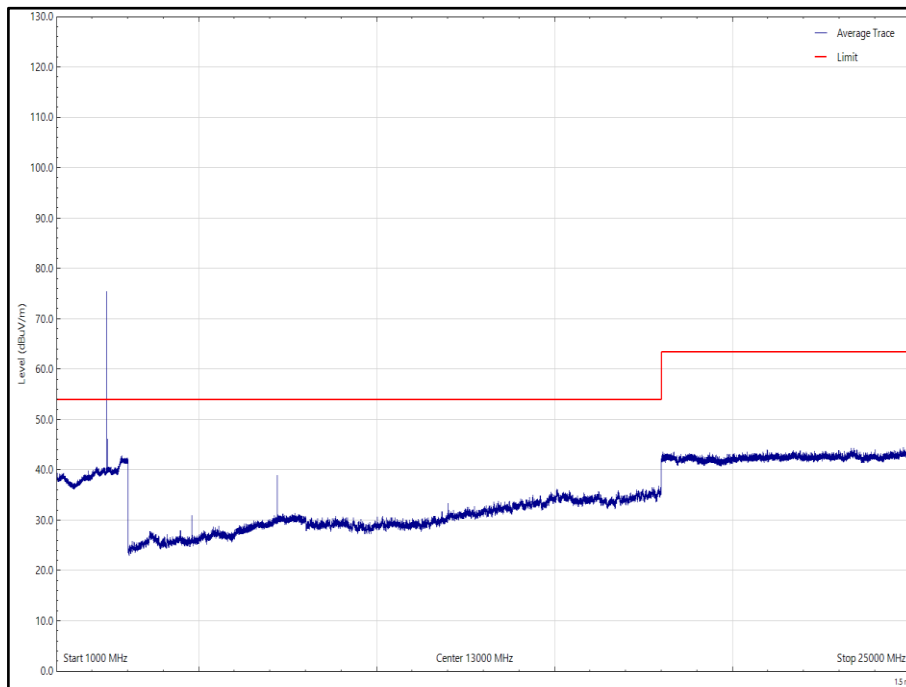

Figure 11 - Proprietary - X, 2402 MHz, 1 GHz to 25 GHz, Horizontal (Average)

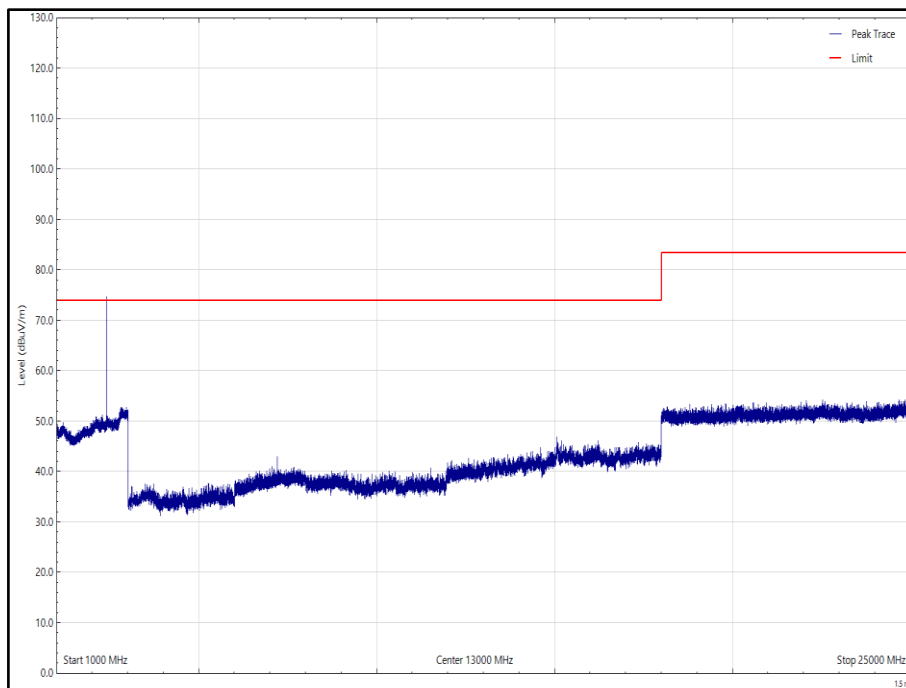

Figure 12 - Proprietary - X, 2402 MHz, 1 GHz to 25 GHz, Horizontal (Peak)

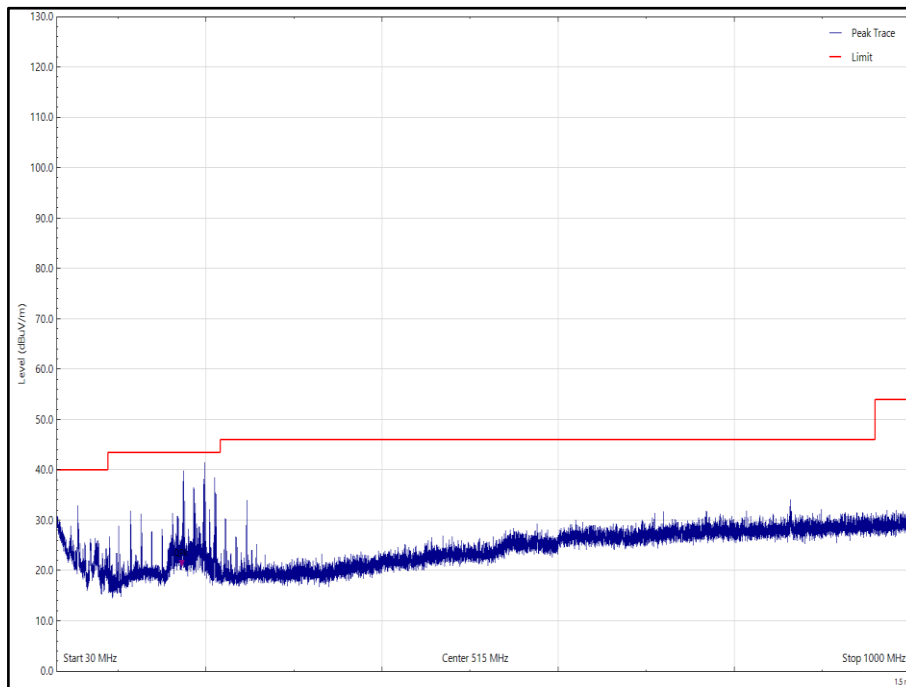

Figure 13 - Proprietary - X, 2402 MHz, 30 MHz to 1 GHz, Vertical (Peak)

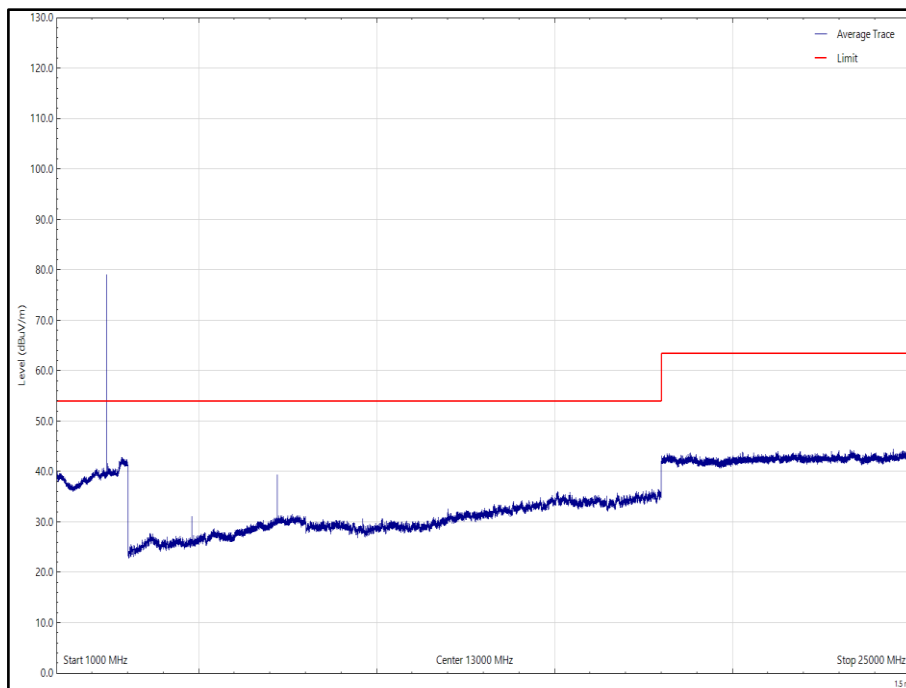

Figure 14 - Proprietary - X, 2402 MHz, 1 GHz to 25 GHz, Vertical (Average)

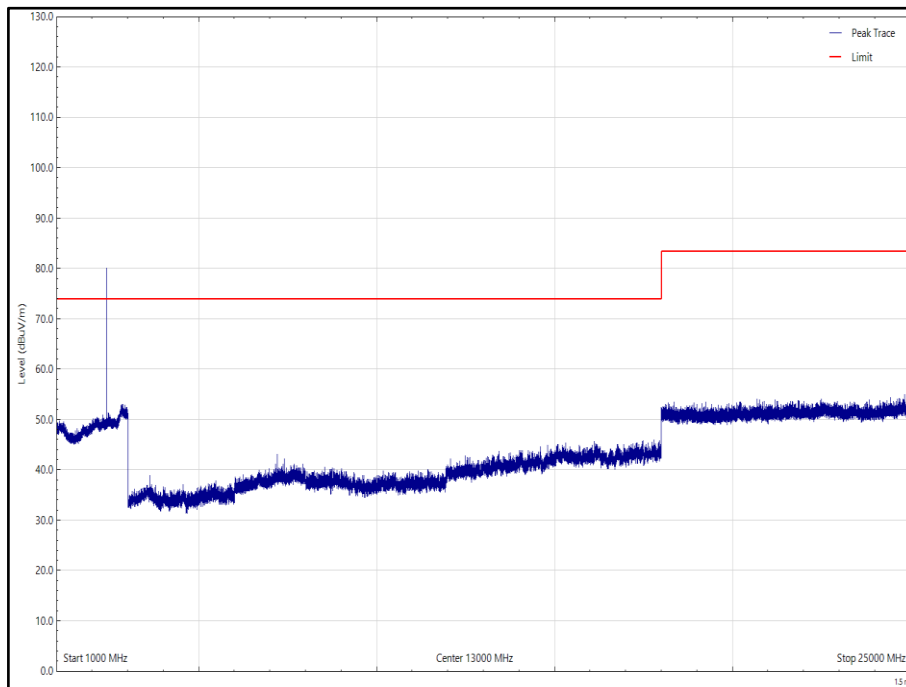

Figure 15 - Proprietary - X, 2402 MHz, 1 GHz to 25 GHz, Vertical (Peak)



Frequency (MHz)	Level (dBuV/m)	Limit (dBuV/m)	Margin (dB)	Detector	Angle (°)	Height (cm)	Polarisation
162.340	28.3	43.5	-15.2	Q-Peak	10	100	Vertical

Table 27 - Proprietary - X, 2440 MHz, 30 MHz to 25 GHz

No other emissions found within 10 dB of the limit.

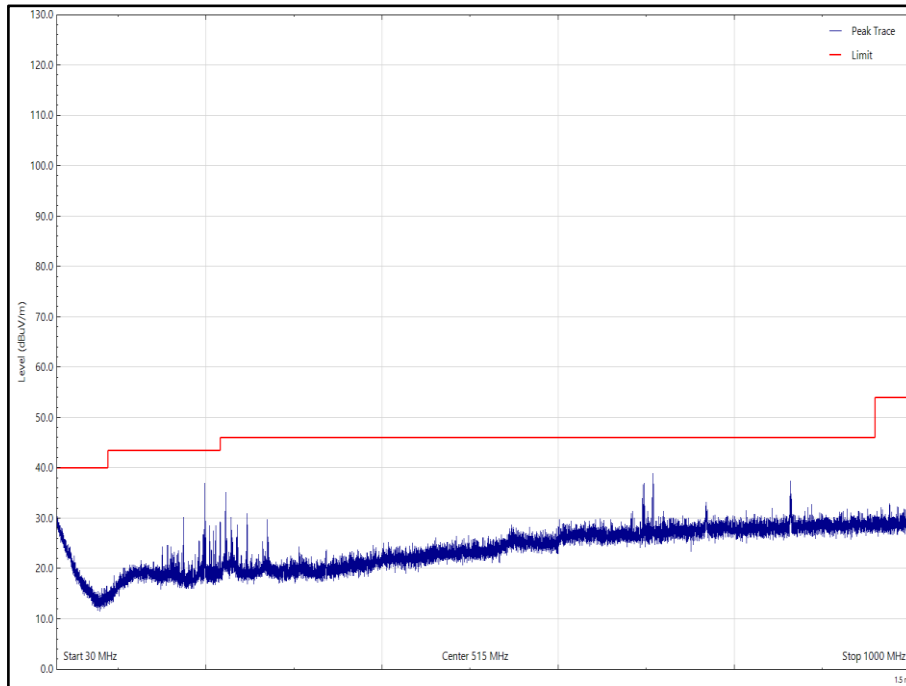

Figure 16 - Proprietary - X, 2440 MHz, 30 MHz to 1 GHz, Horizontal (Peak)

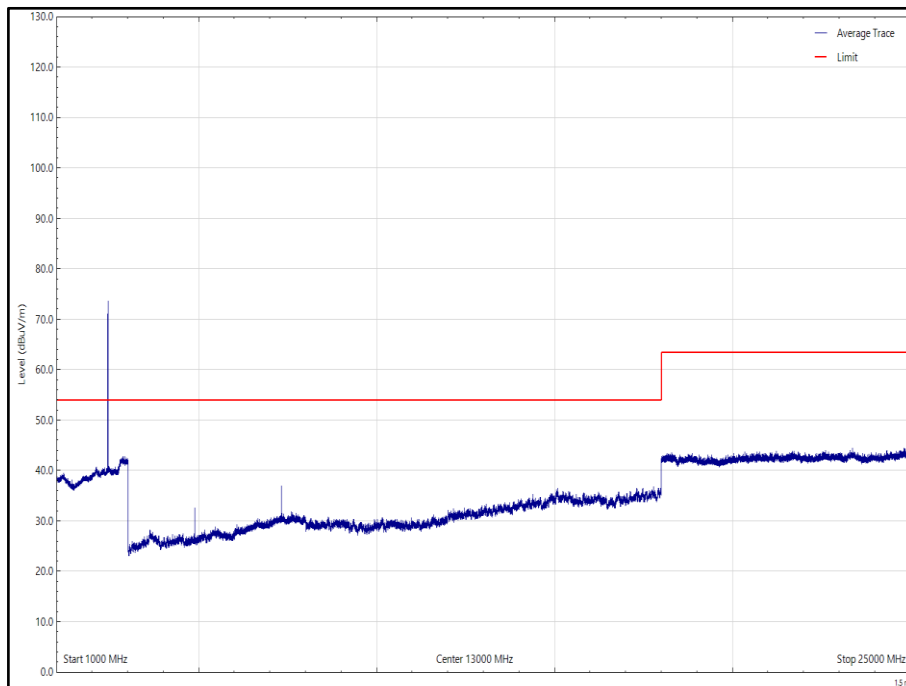

Figure 17 - Proprietary - X, 2440 MHz, 1 GHz to 25 GHz, Horizontal (Average)

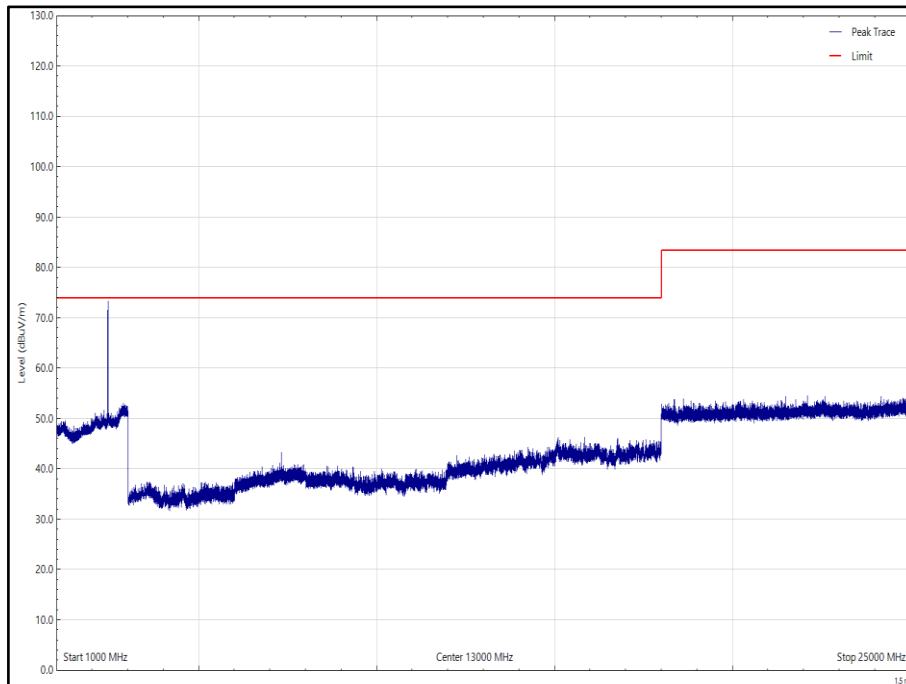

Figure 18 - Proprietary - X, 2440 MHz, 1 GHz to 25 GHz, Horizontal (Peak)

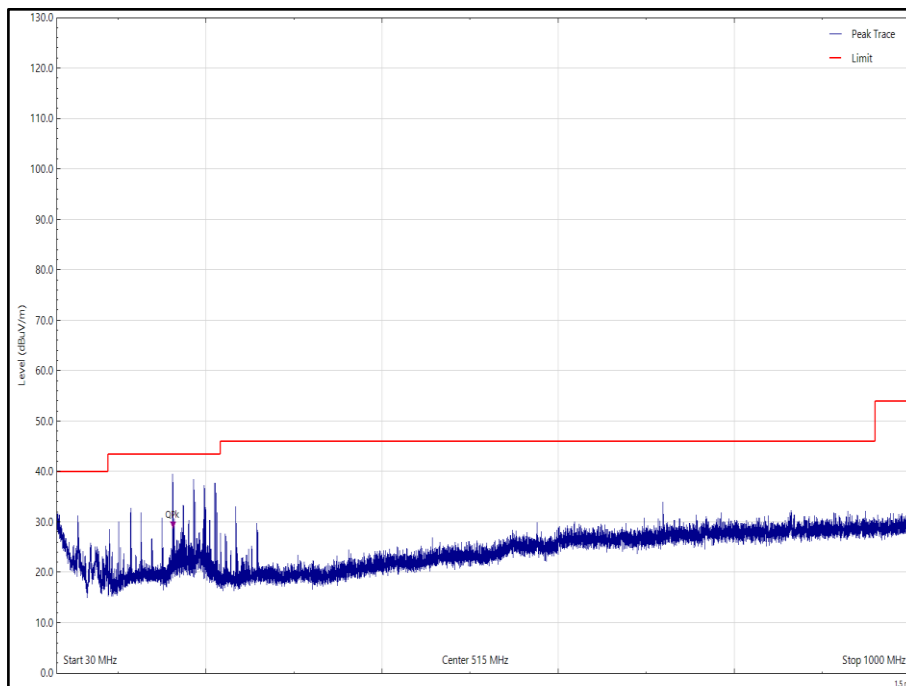

Figure 19 - Proprietary - X, 2440 MHz, 30 MHz to 1 GHz, Vertical (Peak)

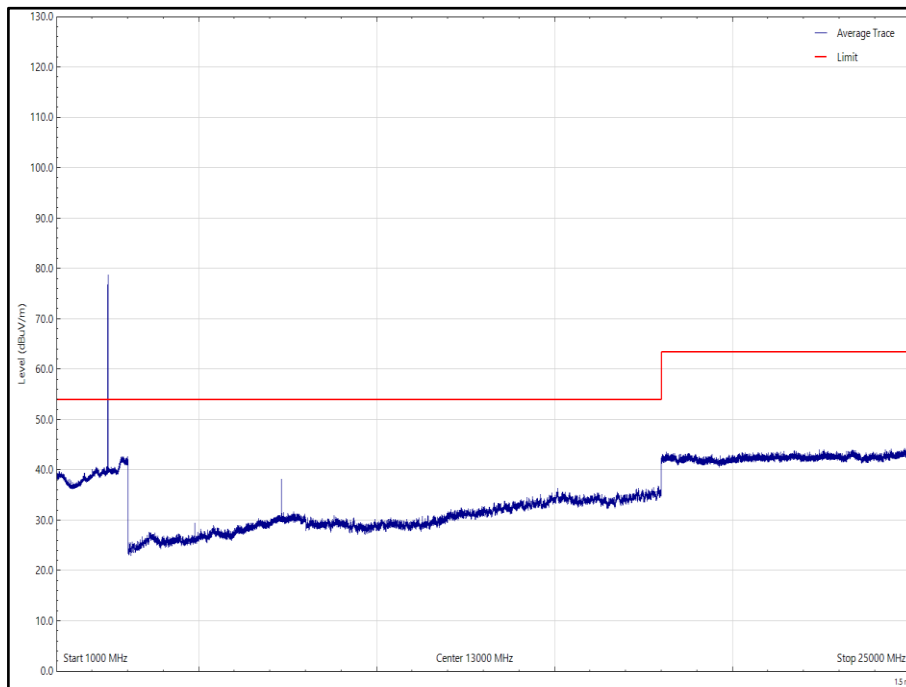

Figure 20 - Proprietary - X, 2440 MHz, 1 GHz to 25 GHz, Vertical (Average)

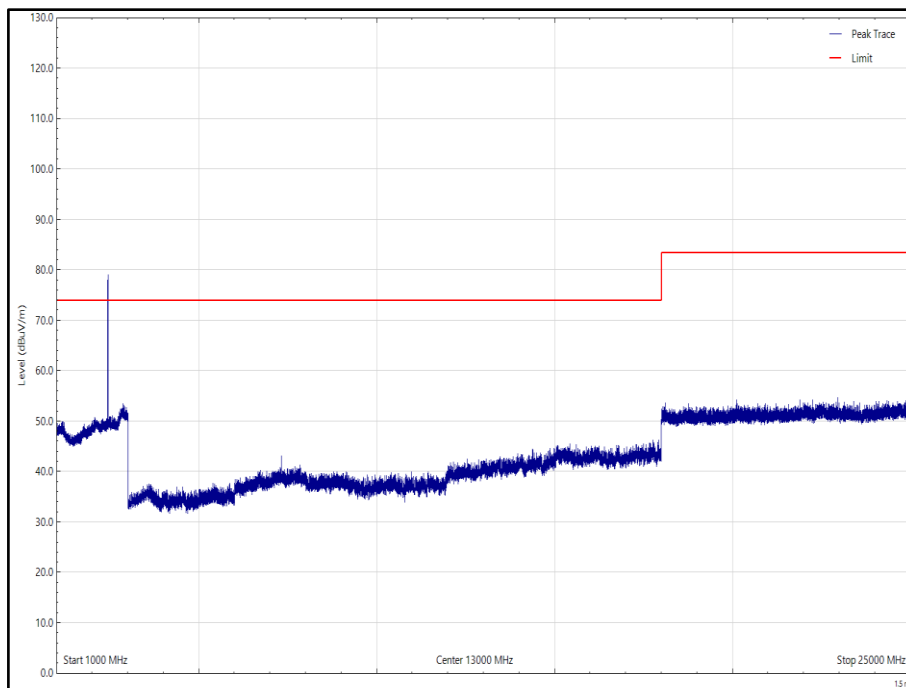

Figure 21 - Proprietary - X, 2440 MHz, 1 GHz to 25 GHz, Vertical (Peak)



Frequency (MHz)	Level (dBuV/m)	Limit (dBuV/m)	Margin (dB)	Detector	Angle (°)	Height (cm)	Polarisation
113.906	26.4	43.5	-17.1	Q-Peak	326	100	Vertical
162.050	32.3	43.5	-11.3	Q-Peak	299	100	Vertical

Table 28 - Proprietary - X, 2480 MHz, 30 MHz to 25 GHz

No other emissions found within 10 dB of the limit.

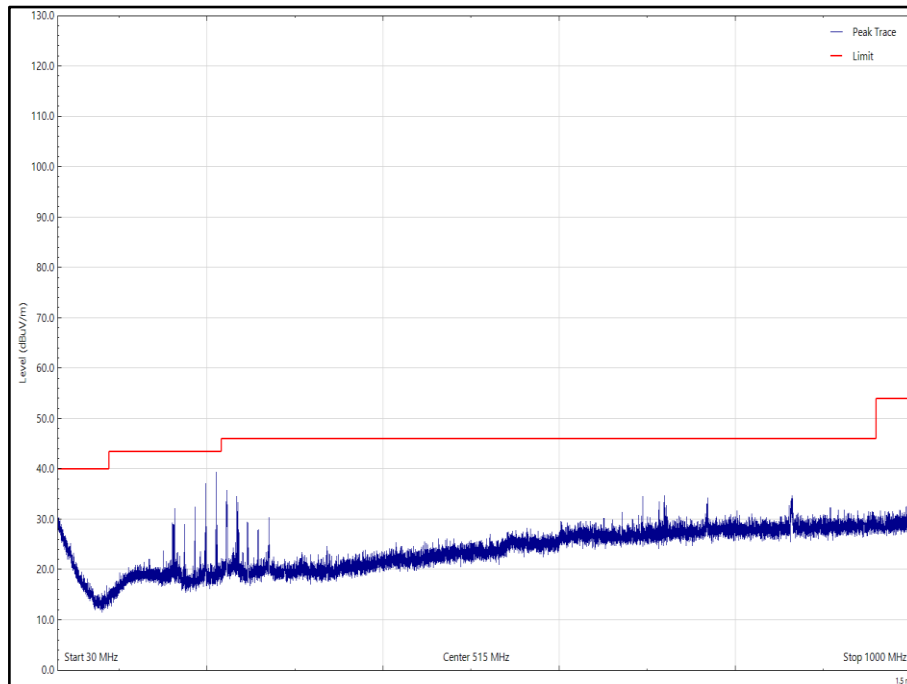

Figure 22 - Proprietary - X, 2480 MHz, 30 MHz to 1 GHz, Horizontal (Peak)

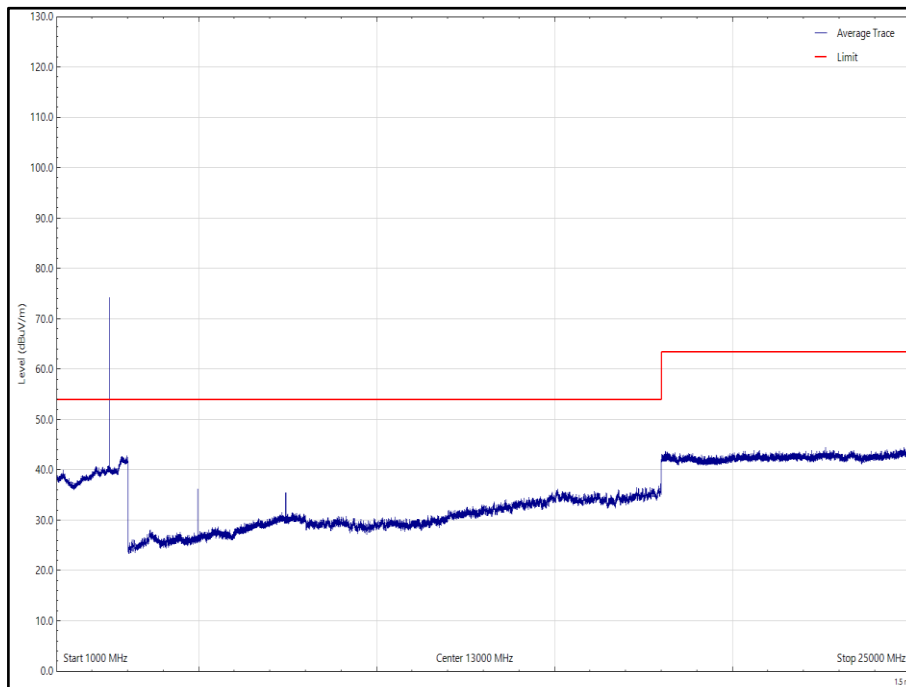

Figure 23 - Proprietary - X, 2480 MHz, 1 GHz to 25 GHz, Horizontal (Average)

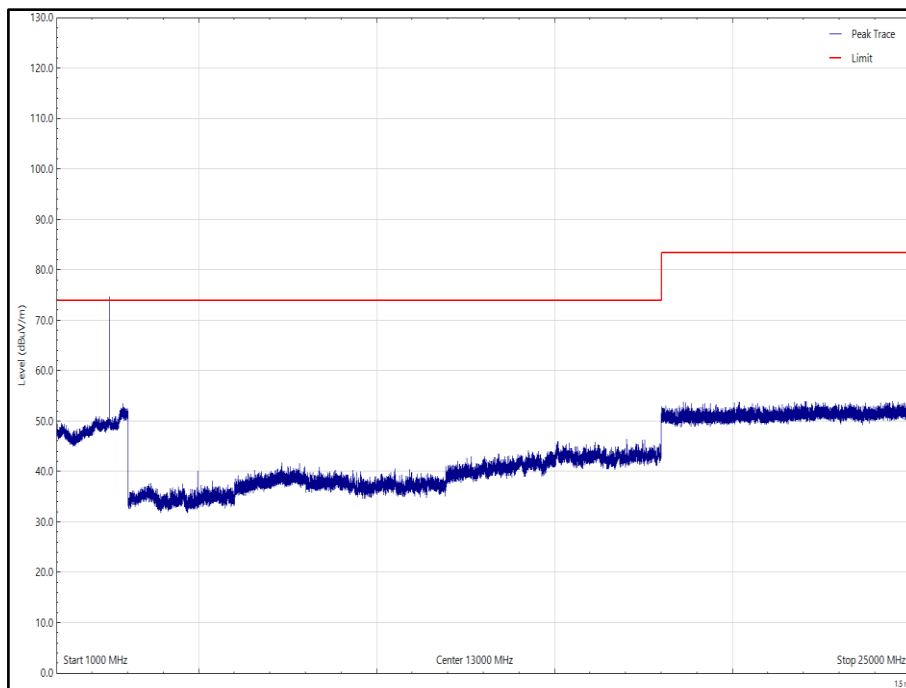

Figure 24 - Proprietary - X, 2480 MHz, 1 GHz to 25 GHz, Horizontal (Peak)

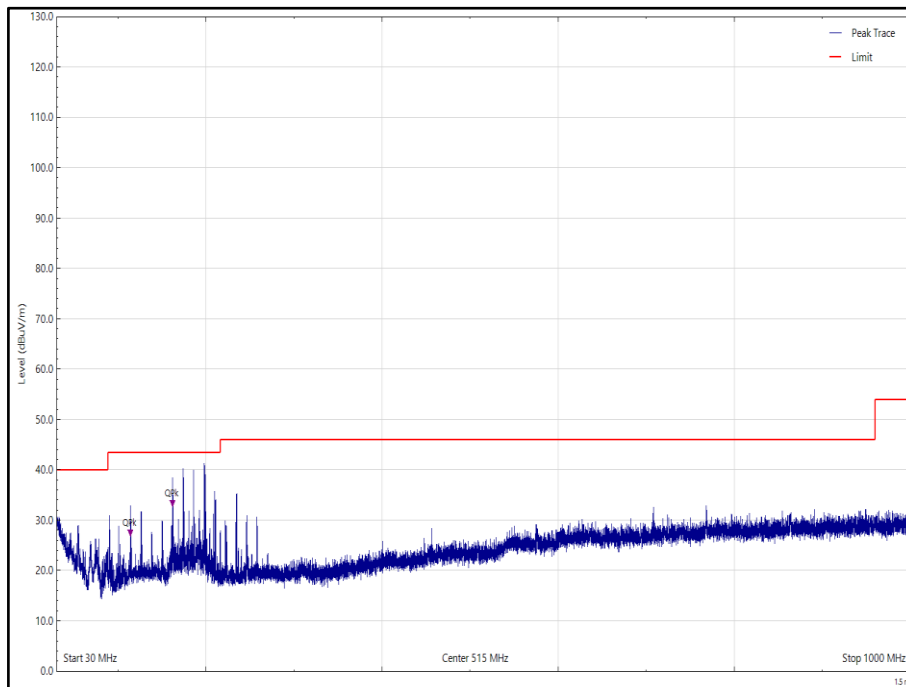

Figure 25 - Proprietary - X, 2480 MHz, 30 MHz to 1 GHz, Vertical (Peak)

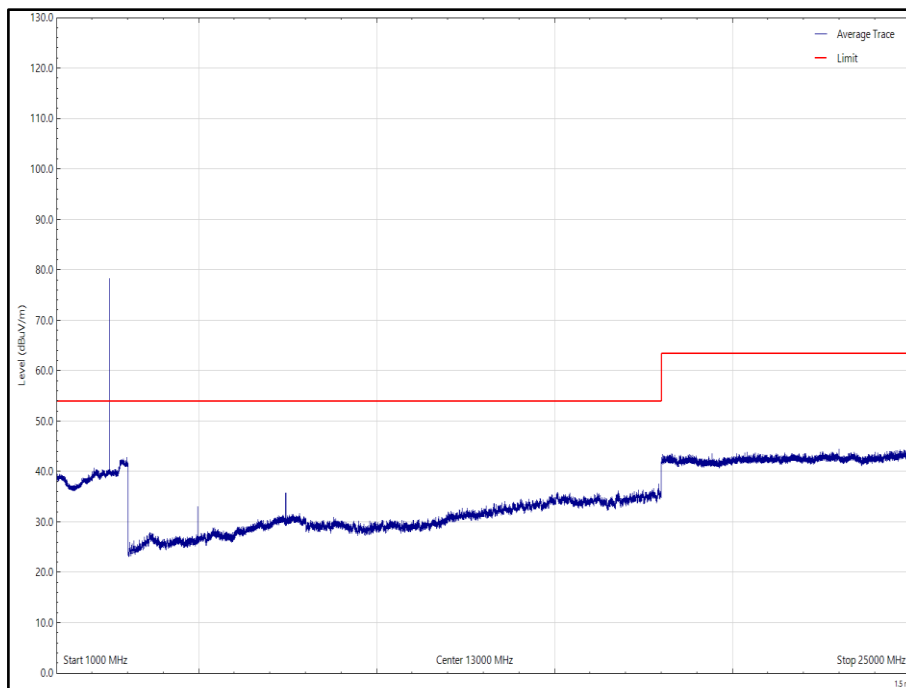

Figure 26 - Proprietary - X, 2480 MHz, 1 GHz to 25 GHz, Vertical (Average)

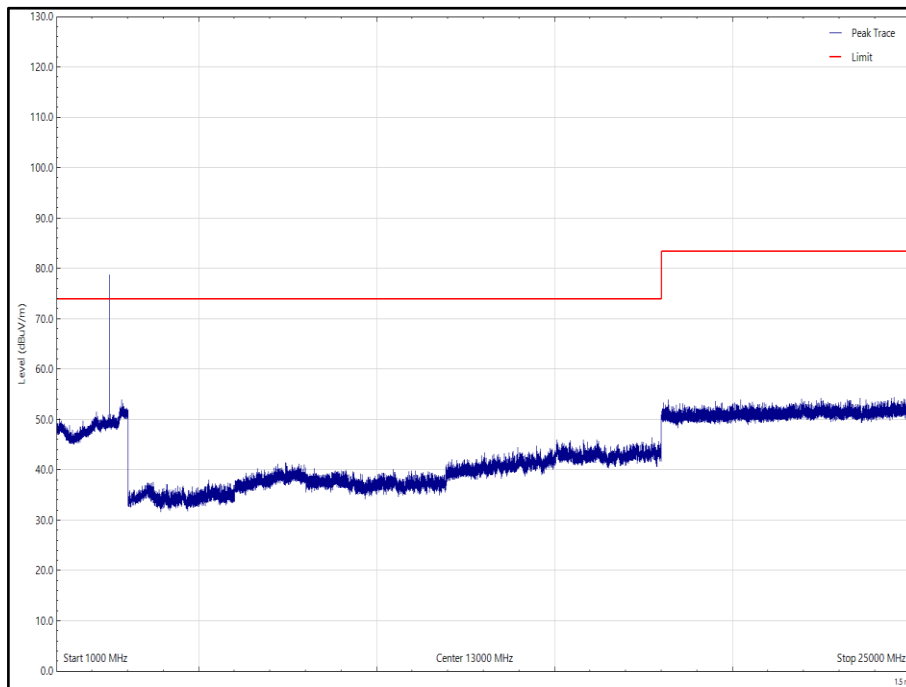

Figure 27 - Proprietary - X, 2480 MHz, 1 GHz to 25 GHz, Vertical (Peak)



Frequency (MHz)	Level (dBuV/m)	Limit (dBuV/m)	Margin (dB)	Detector	Angle (°)	Height (cm)	Polarisation
125.764	23.2	43.5	-20.3	Q-Peak	233	100	Vertical

Table 29 - Proprietary - Y, 2402 MHz, 30 MHz to 25 GHz

No other emissions found within 10 dB of the limit.

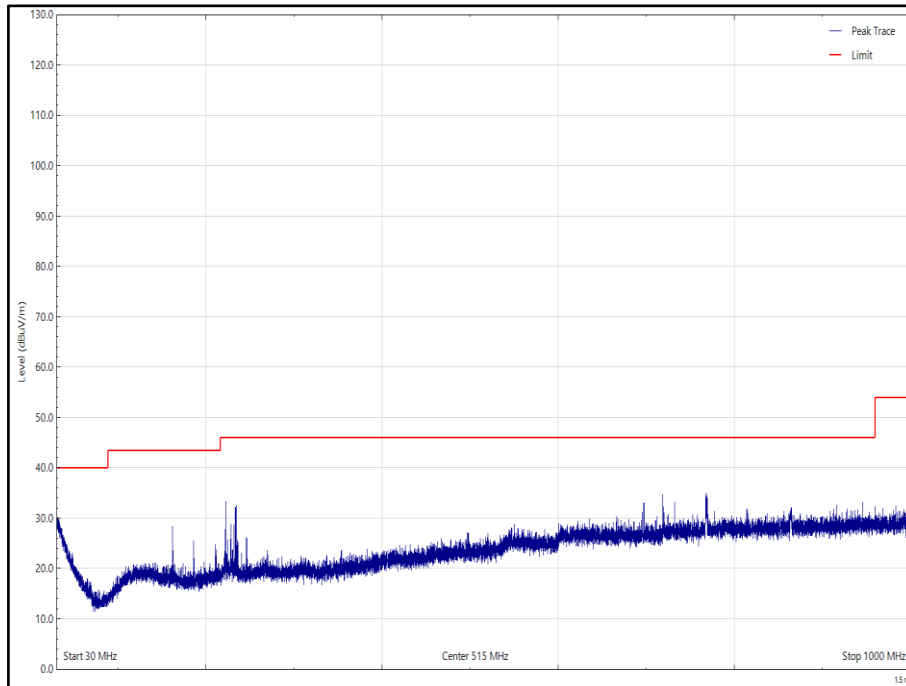

Figure 28 - Proprietary - Y, 2402 MHz, 30 MHz to 1 GHz, Horizontal (Peak)

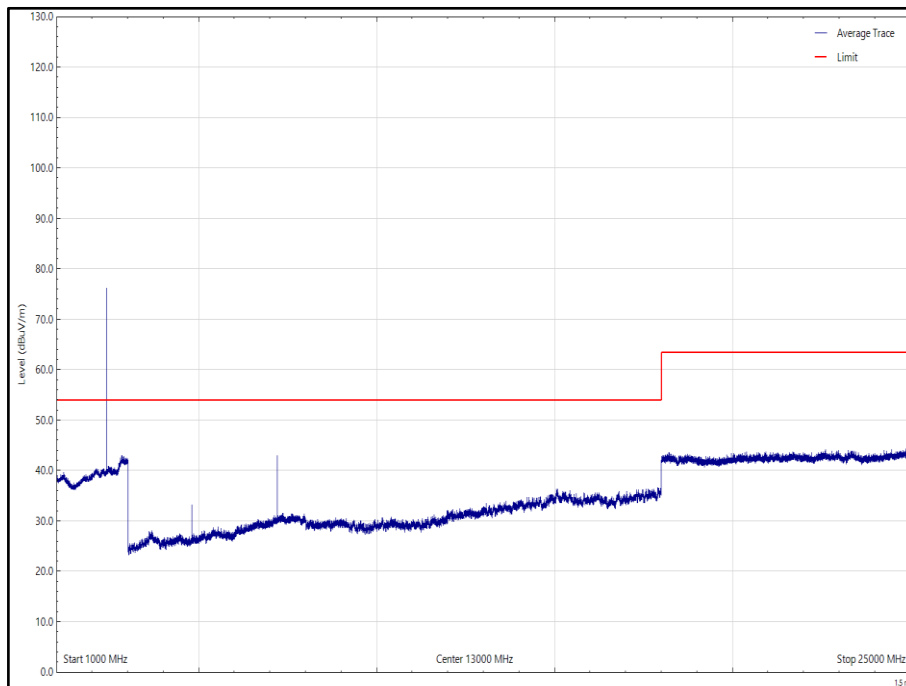

Figure 29 - Proprietary - Y, 2402 MHz, 1 GHz to 25 GHz, Horizontal (Average)

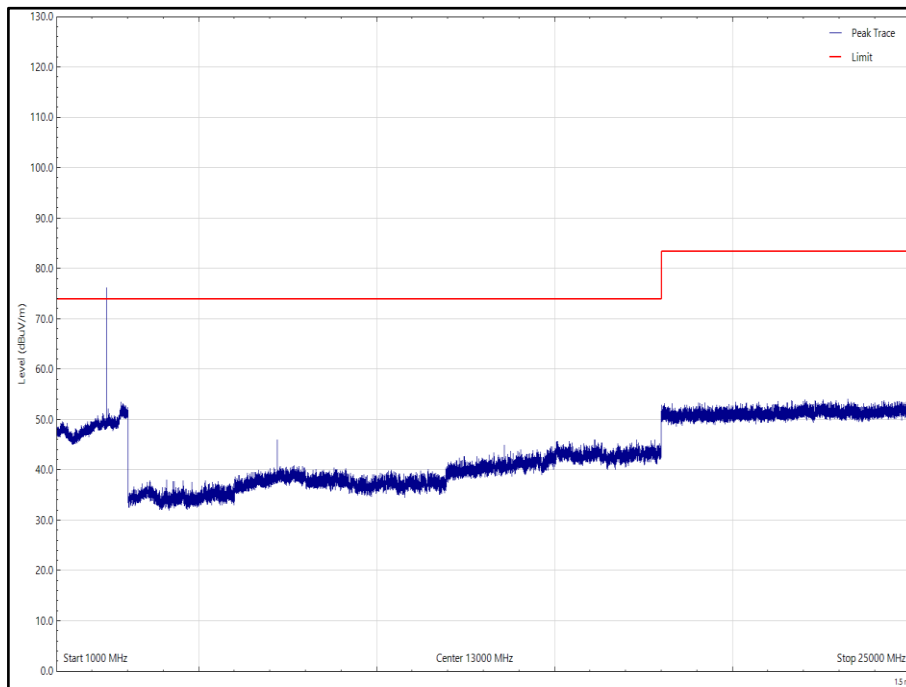

Figure 30 - Proprietary - Y, 2402 MHz, 1 GHz to 25 GHz, Horizontal (Peak)

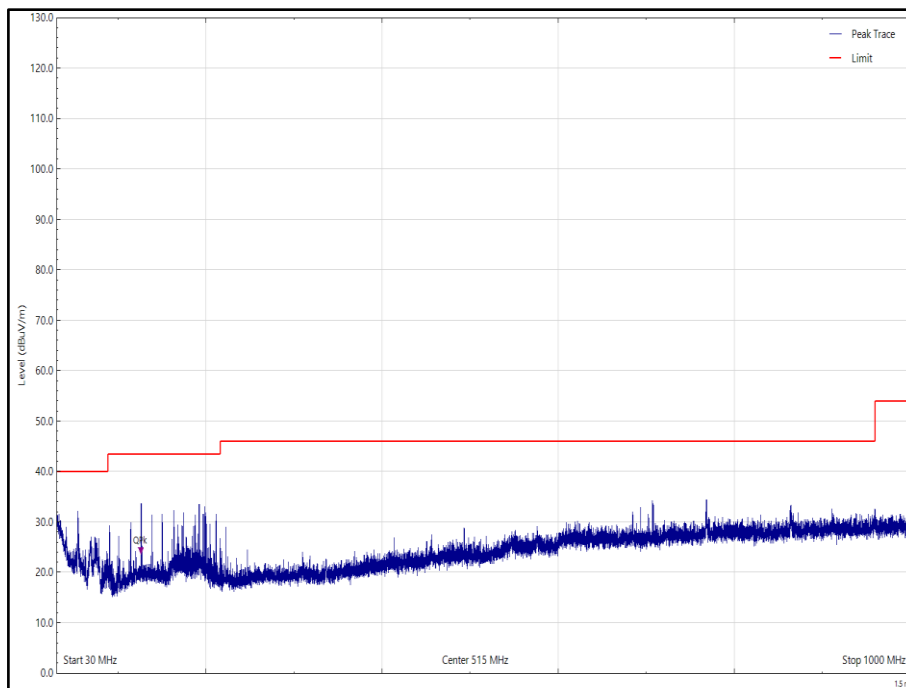

Figure 31 - Proprietary - Y, 2402 MHz, 30 MHz to 1 GHz, Vertical (Peak)

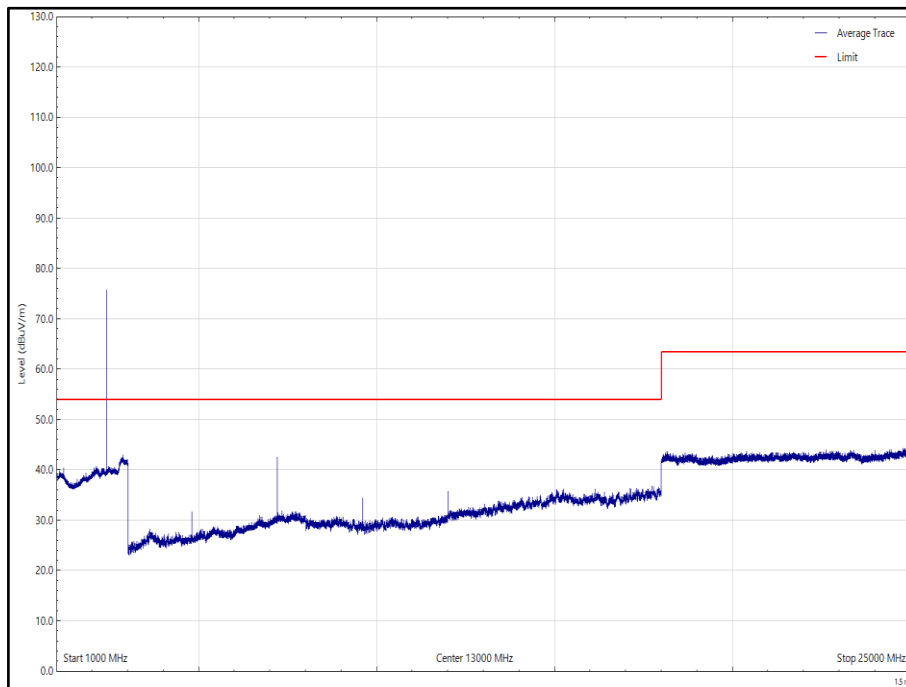

Figure 32 - Proprietary - Y, 2402 MHz, 1 GHz to 25 GHz, Vertical (Average)

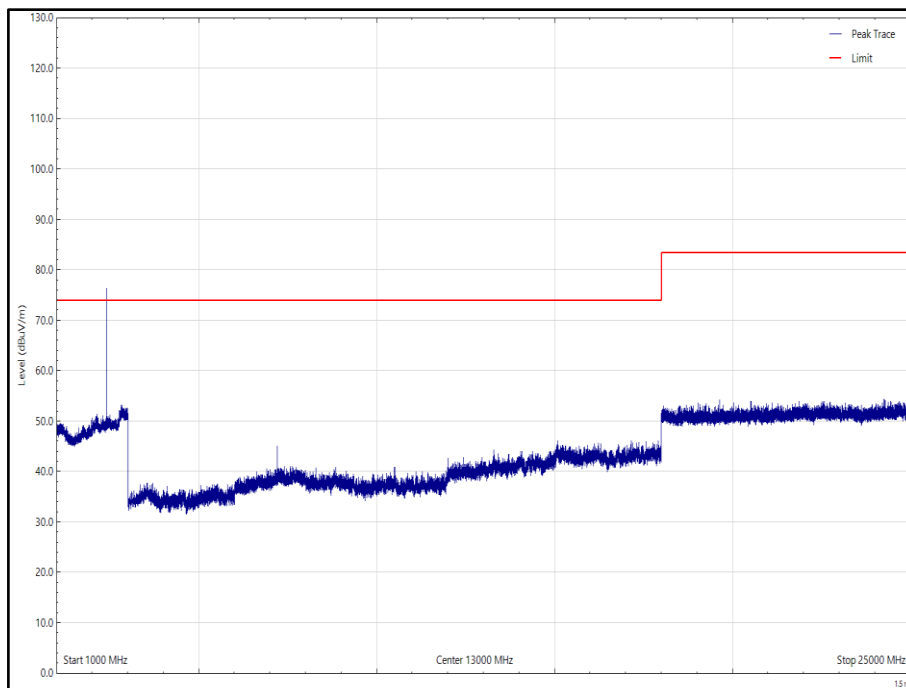

Figure 33 - Proprietary - Y, 2402 MHz, 1 GHz to 25 GHz, Vertical (Peak)



Frequency (MHz)	Level (dBuV/m)	Limit (dBuV/m)	Margin (dB)	Detector	Angle (°)	Height (cm)	Polarisation
162.161	30.9	43.5	-12.6	Q-Peak	350	100	Vertical

Table 30 - Proprietary - Y, 2440 MHz, 30 MHz to 25 GHz

No other emissions found within 10 dB of the limit.

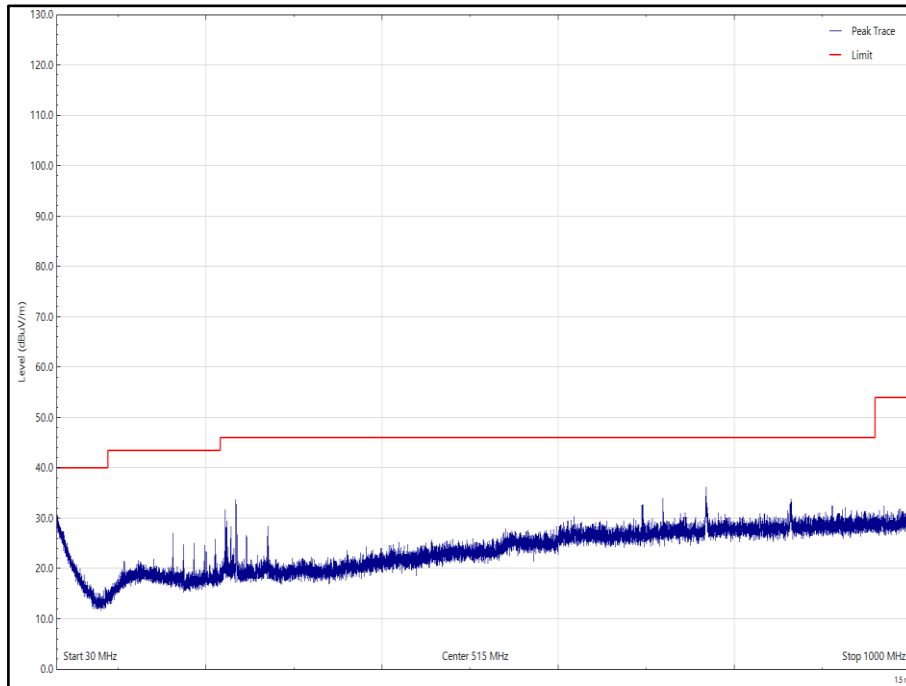

Figure 34 - Proprietary - Y, 2440 MHz, 30 MHz to 1 GHz, Horizontal (Peak)

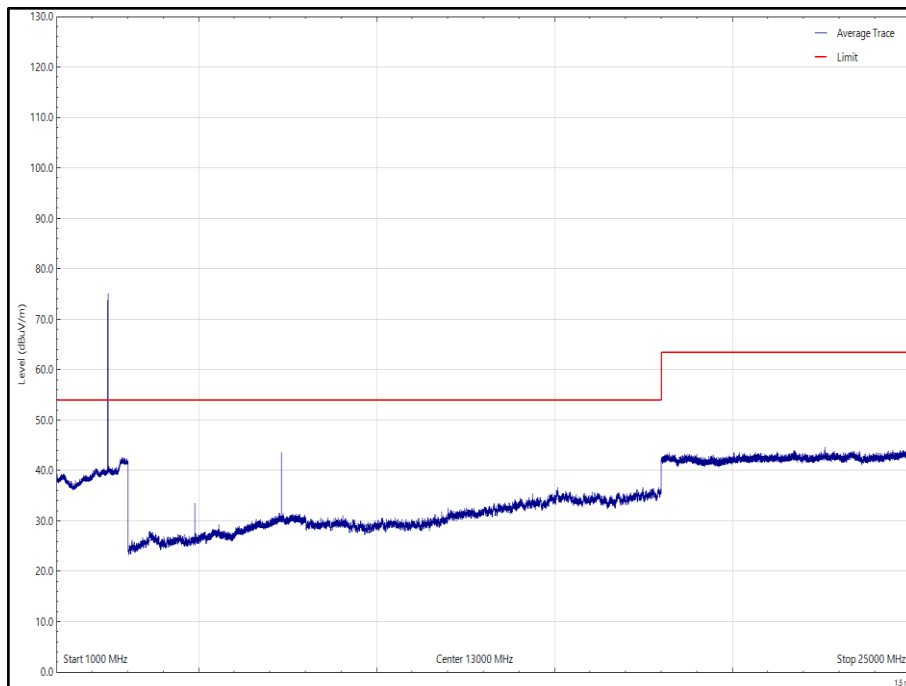

Figure 35 - Proprietary - Y, 2440 MHz, 1 GHz to 25 GHz, Horizontal (Average)

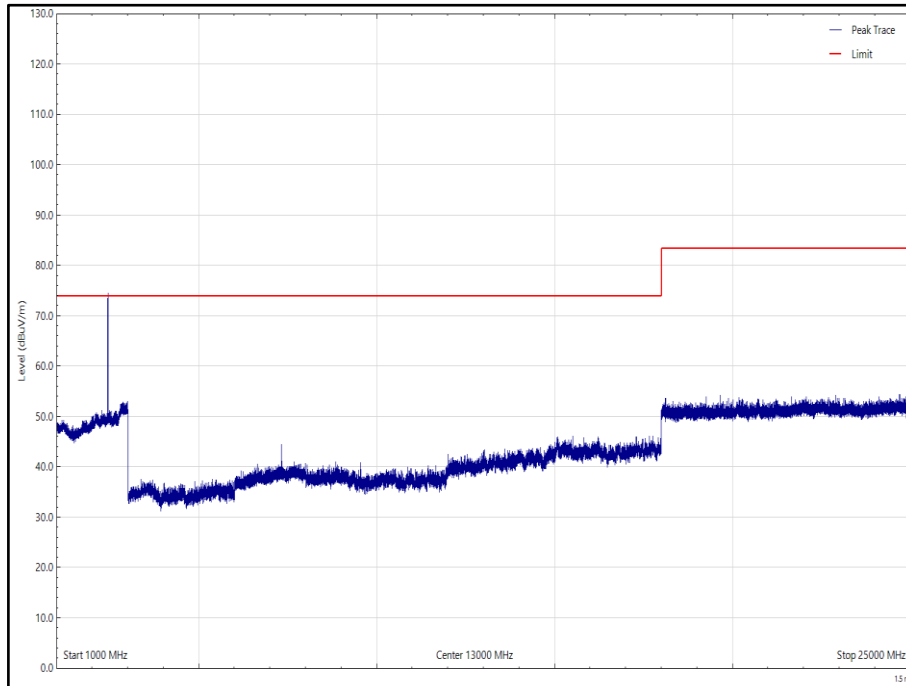

Figure 36 - Proprietary - Y, 2440 MHz, 1 GHz to 25 GHz, Horizontal (Peak)

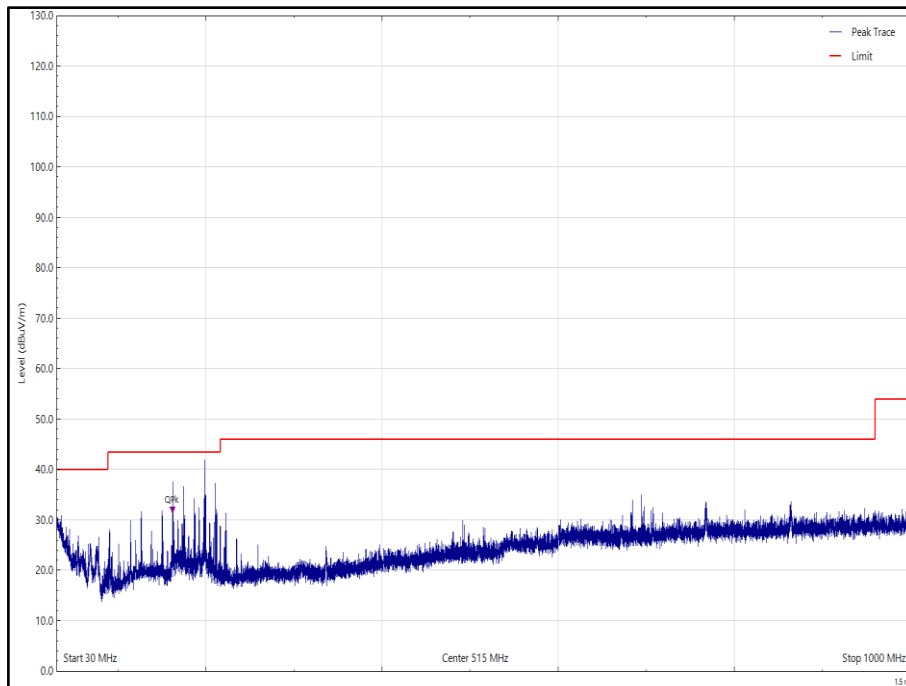

Figure 37 - Proprietary - Y, 2440 MHz, 30 MHz to 1 GHz, Vertical (Peak)

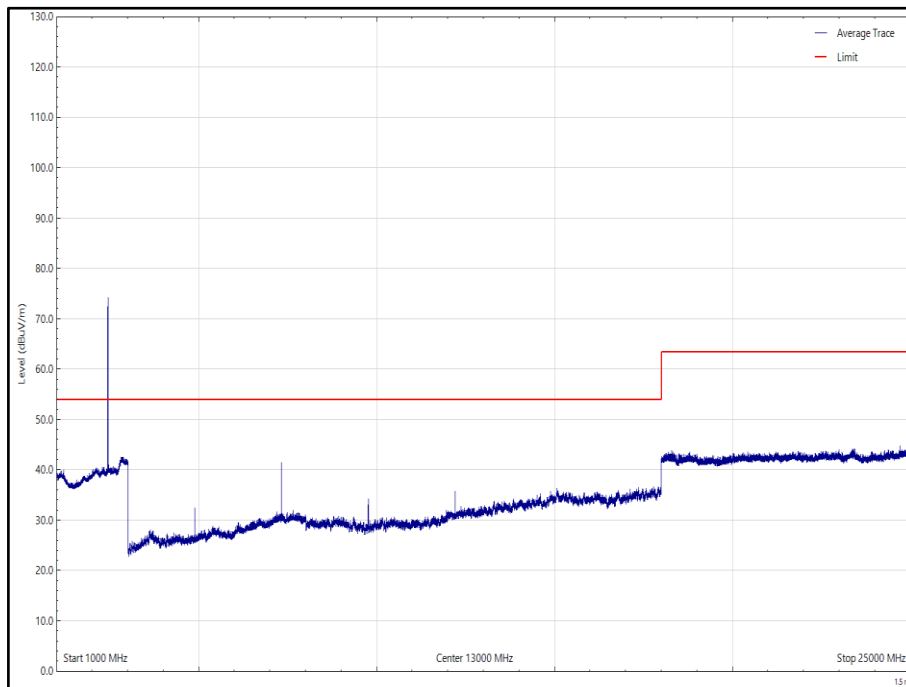

Figure 38 - Proprietary - Y, 2440 MHz, 1 GHz to 25 GHz, Vertical (Average)

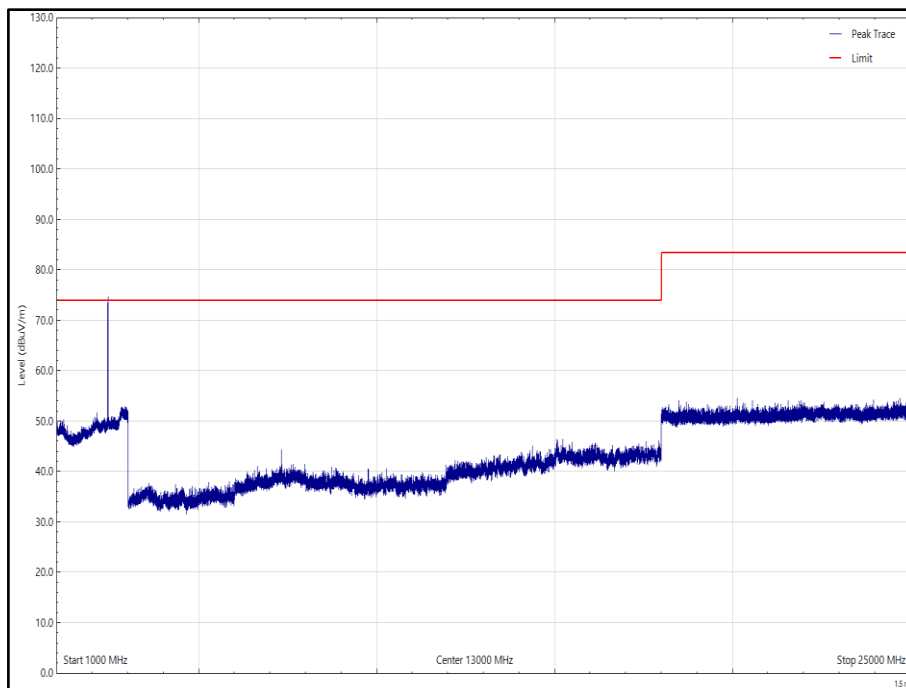

Figure 39 - Proprietary - Y, 2440 MHz, 1 GHz to 25 GHz, Vertical (Peak)



Frequency (MHz)	Level (dBuV/m)	Limit (dBuV/m)	Margin (dB)	Detector	Angle (°)	Height (cm)	Polarisation
*							

Table 31 - Proprietary - Y, 2480 MHz, 30 MHz to 25 GHz

*No emissions found within 10 dB of the limit.

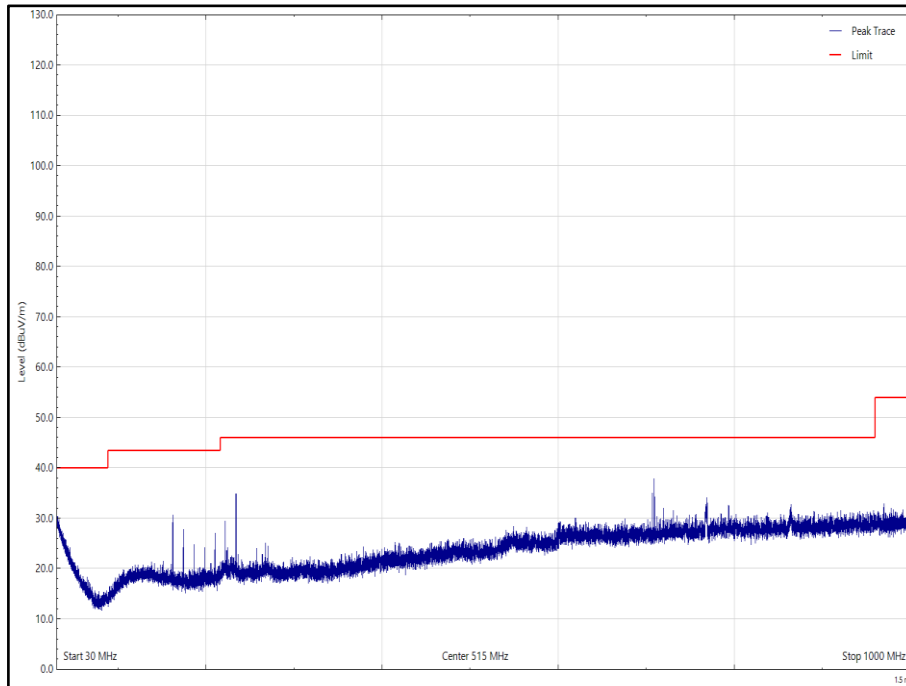

Figure 40 - Proprietary - Y, 2480 MHz, 30 MHz to 1 GHz, Horizontal (Peak)

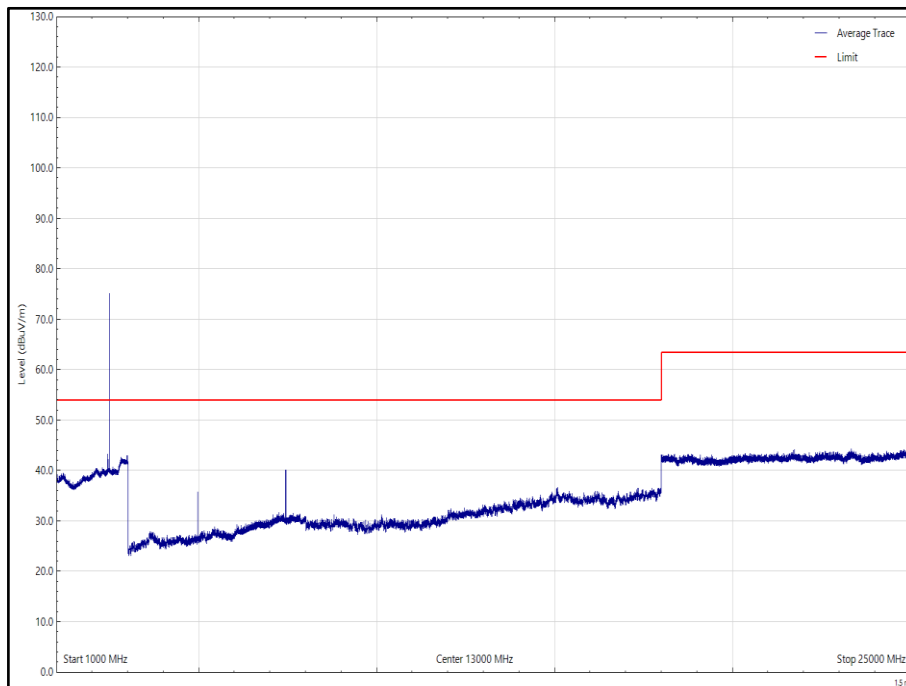

Figure 41 - Proprietary - Y, 2480 MHz, 1 GHz to 25 GHz, Horizontal (Average)

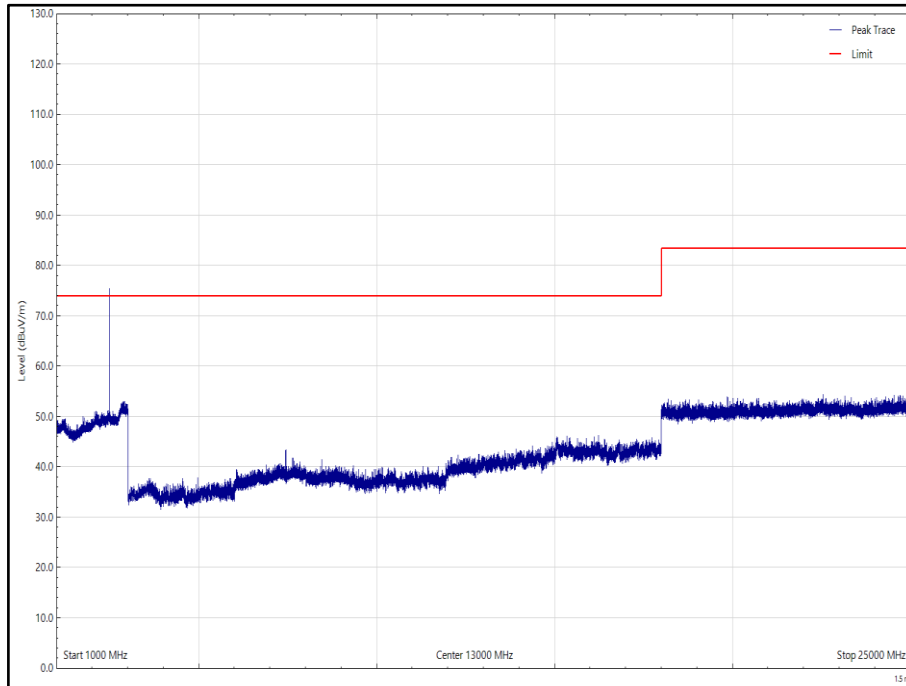

Figure 42 - Proprietary - Y, 2480 MHz, 1 GHz to 25 GHz, Horizontal (Peak)

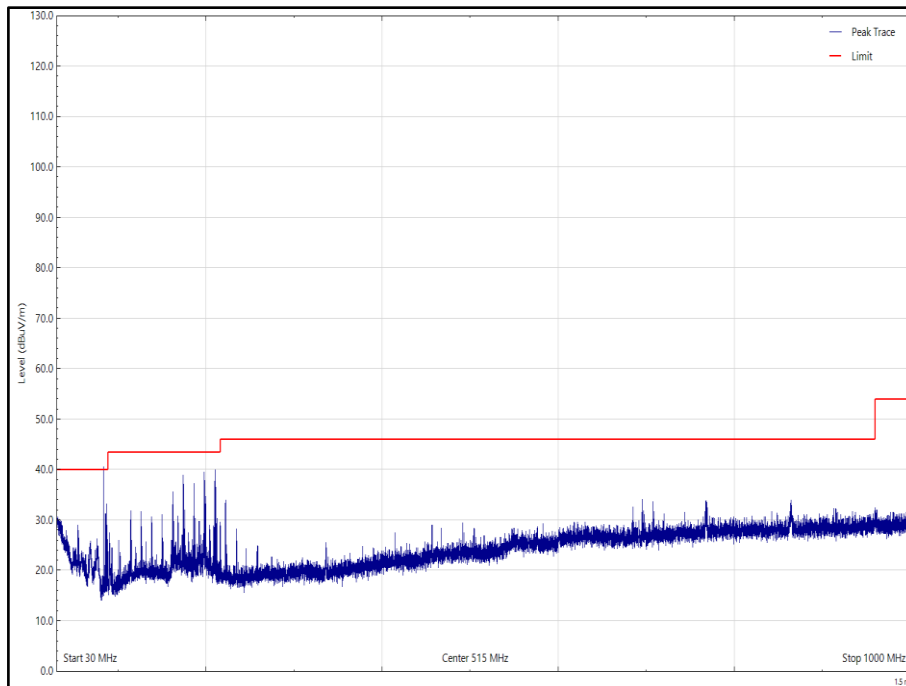

Figure 43 - Proprietary - Y, 2480 MHz, 30 MHz to 1 GHz, Vertical (Peak)

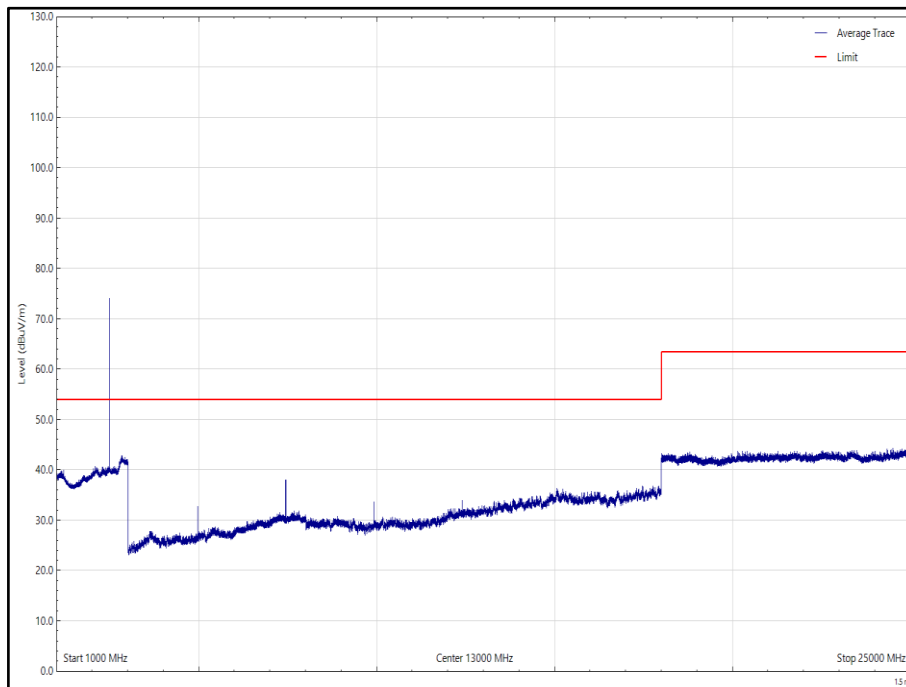

Figure 44 - Proprietary - Y, 2480 MHz, 1 GHz to 25 GHz, Vertical (Average)

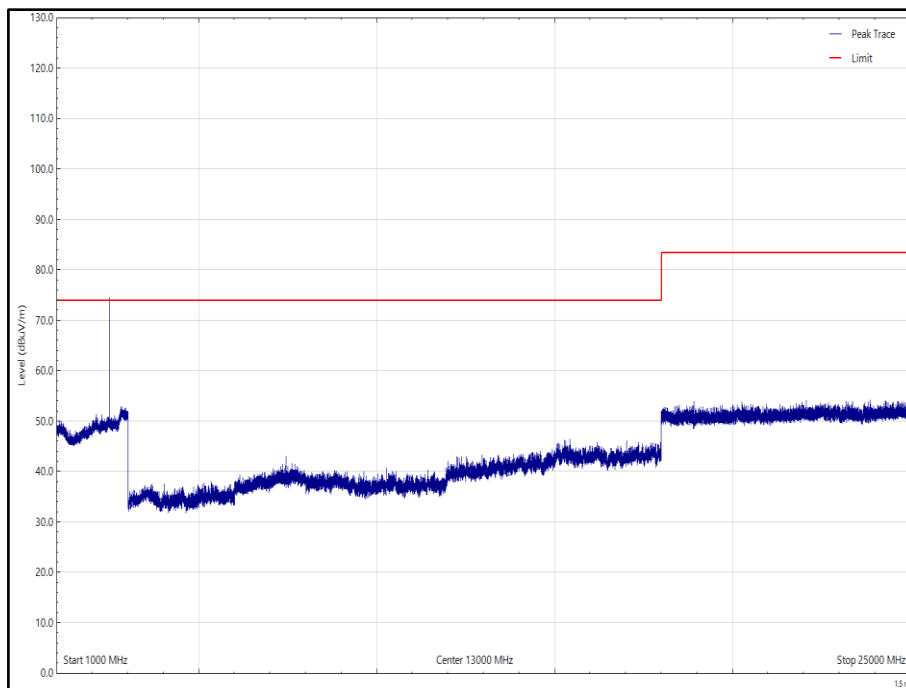

Figure 45 - Proprietary - Y, 2480 MHz, 1 GHz to 25 GHz, Vertical (Peak)



Frequency (MHz)	Level (dBuV/m)	Limit (dBuV/m)	Margin (dB)	Detector	Angle (°)	Height (cm)	Polarisation
162.379	28.5	43.5	-15.0	Q-Peak	269	100	Vertical

Table 32 - Proprietary - Z, 2402 MHz, 30 MHz to 25 GHz

No other emissions found within 10 dB of the limit.

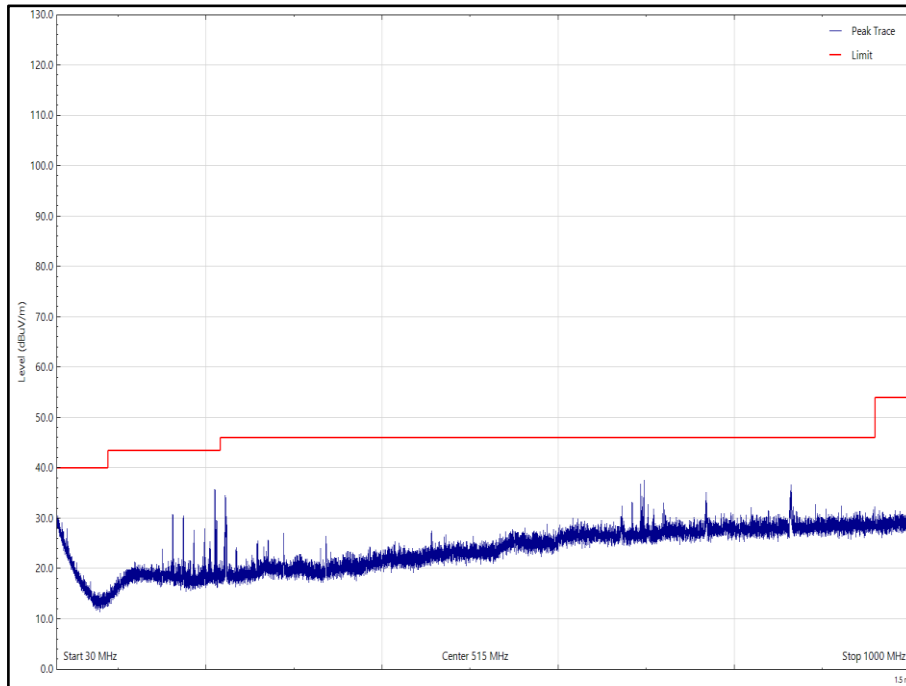

Figure 46 - Proprietary - Z, 2402 MHz, 30 MHz to 1 GHz, Horizontal (Peak)

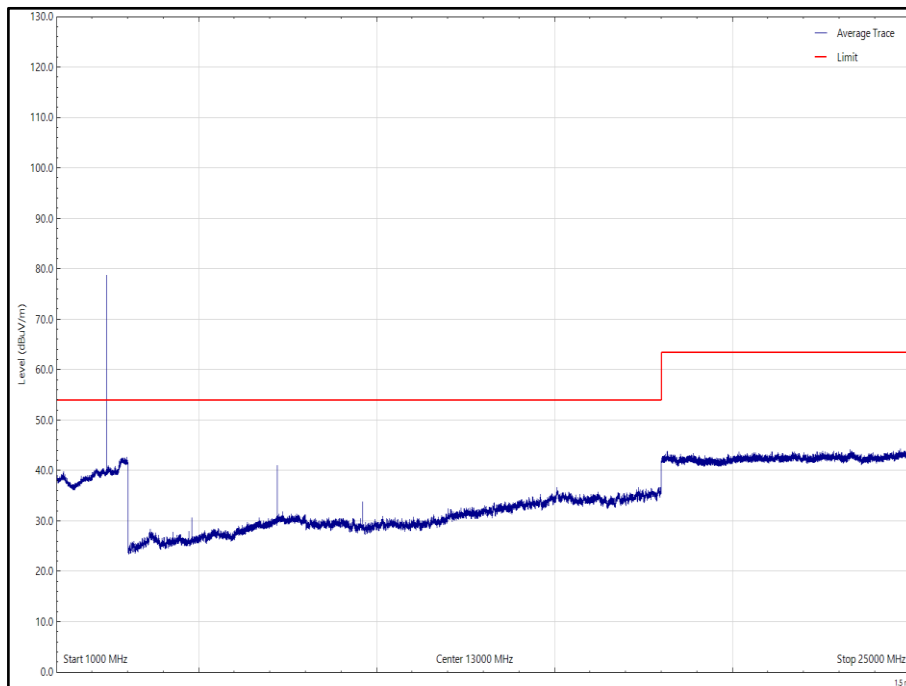

Figure 47 - Proprietary - Z, 2402 MHz, 1 GHz to 25 GHz, Horizontal (Average)

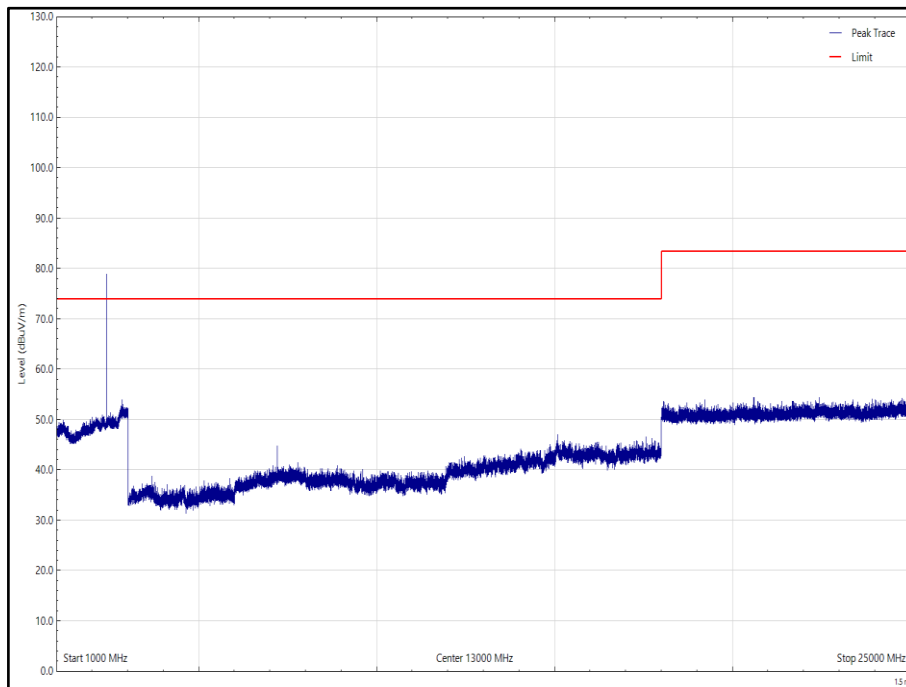

Figure 48 - Proprietary - Z, 2402 MHz, 1 GHz to 25 GHz, Horizontal (Peak)

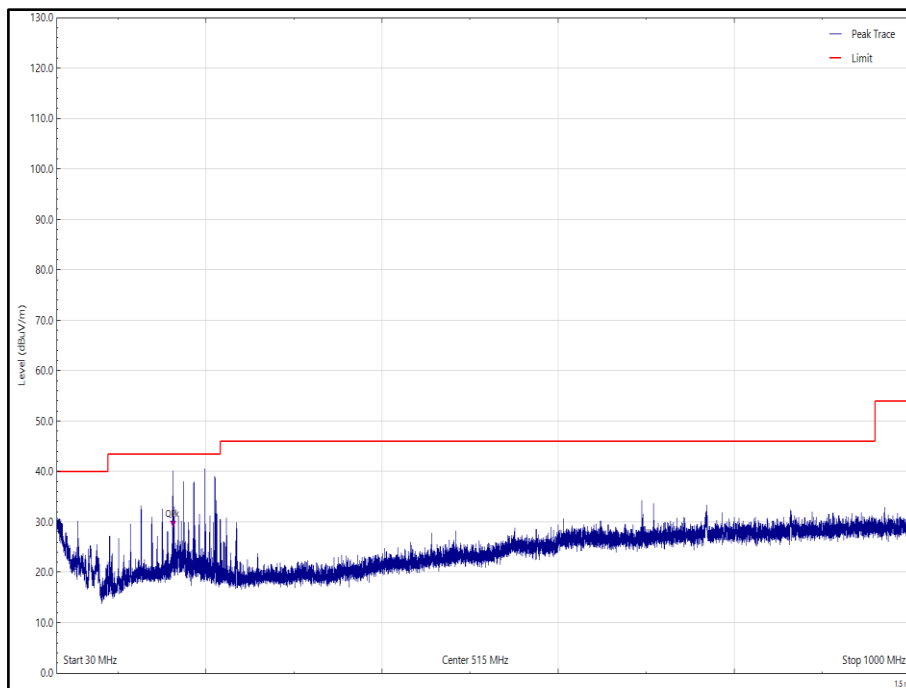

Figure 49 - Proprietary - Z, 2402 MHz, 30 MHz to 1 GHz, Vertical (Peak)

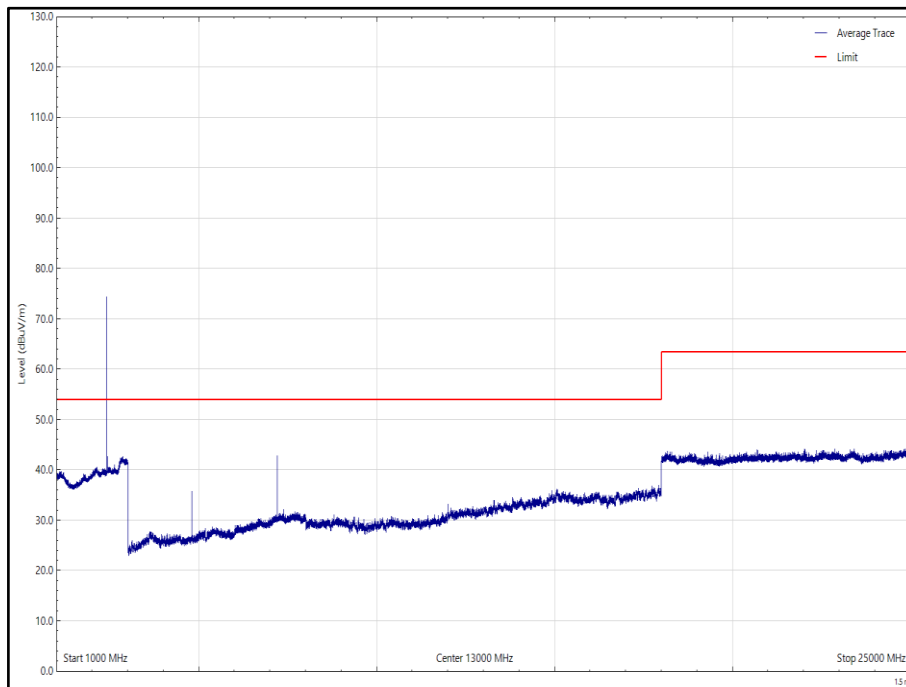

Figure 50 - Proprietary - Z, 2402 MHz, 1 GHz to 25 GHz, Vertical (Average)

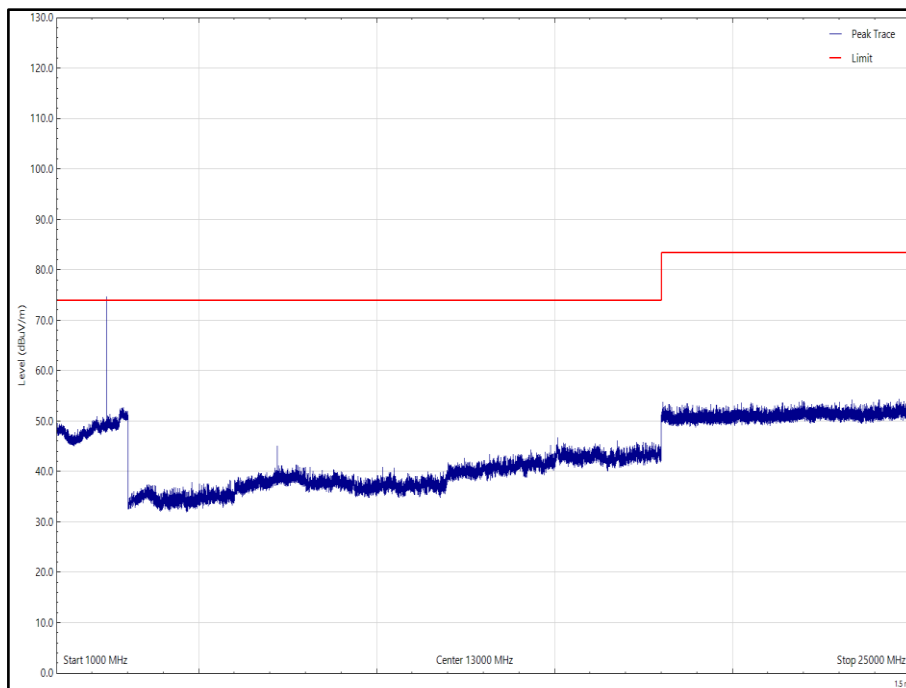

Figure 51 - Proprietary - Z, 2402 MHz, 1 GHz to 25 GHz, Vertical (Peak)



Frequency (MHz)	Level (dBuV/m)	Limit (dBuV/m)	Margin (dB)	Detector	Angle (°)	Height (cm)	Polarisation
114.214	24.6	43.5	-19.0	Q-Peak	10	100	Vertical
150.256	27.0	43.5	-16.5	Q-Peak	309	100	Vertical

Table 33 - Proprietary - Z, 2440 MHz, 30 MHz to 25 GHz

No other emissions found within 10 dB of the limit.

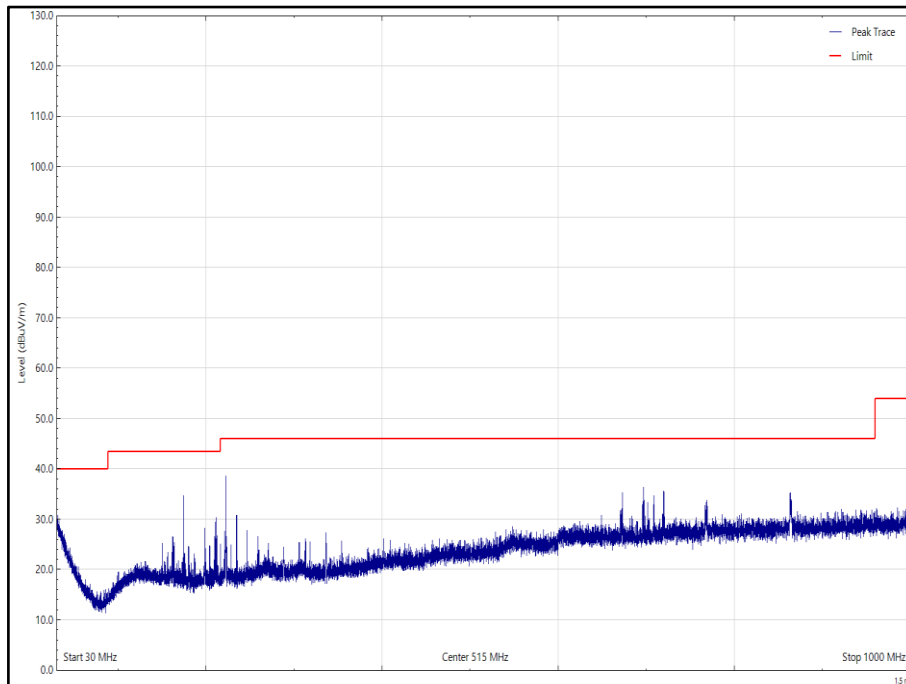

Figure 52 - Proprietary - Z, 2440 MHz, 30 MHz to 1 GHz, Horizontal (Peak)

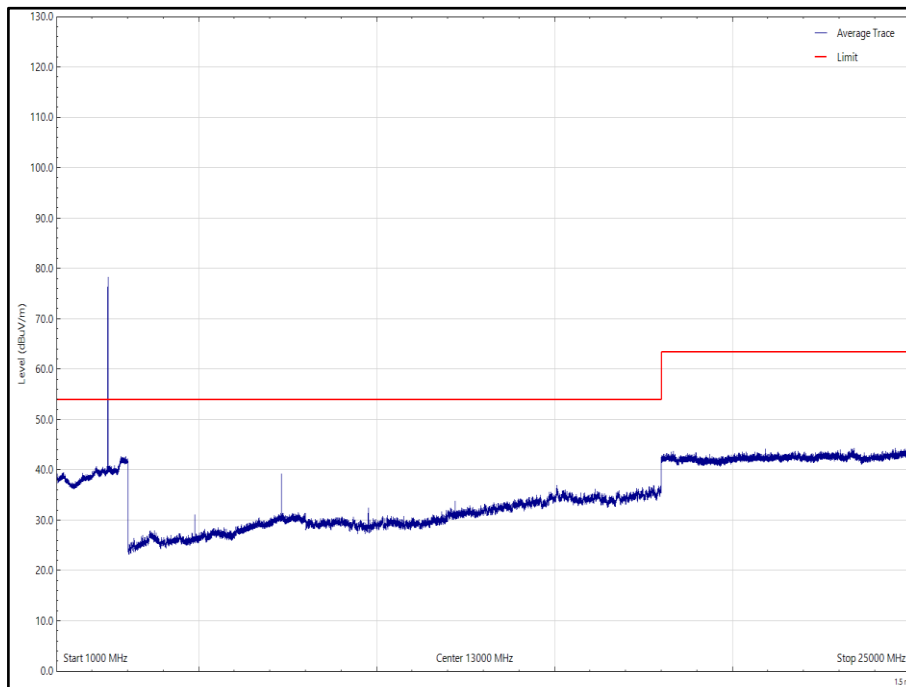

Figure 53 - Proprietary - Z, 2440 MHz, 1 GHz to 25 GHz, Horizontal (Average)

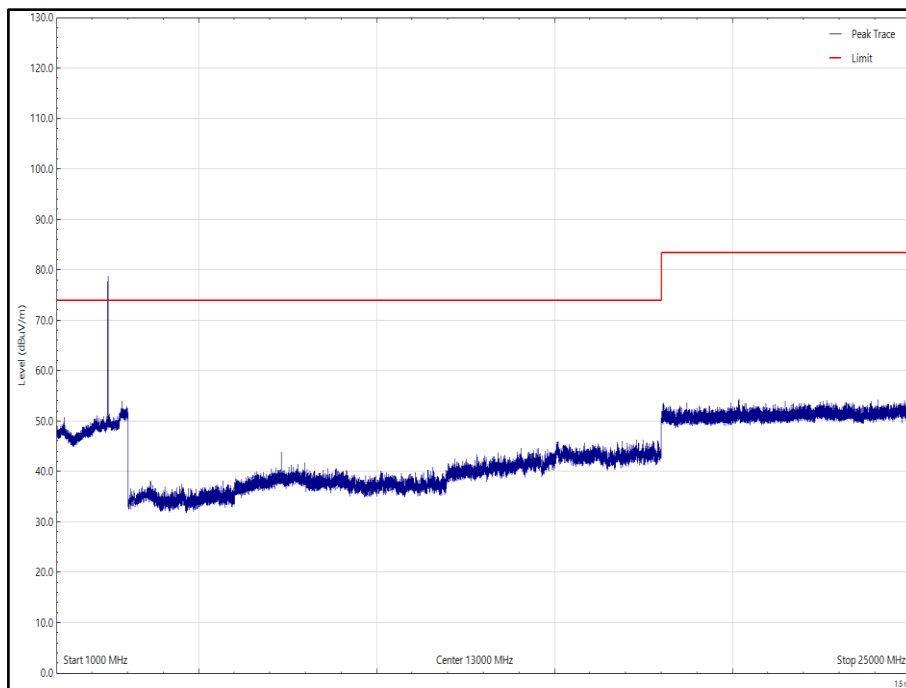

Figure 54 - Proprietary - Z, 2440 MHz, 1 GHz to 25 GHz, Horizontal (Peak)

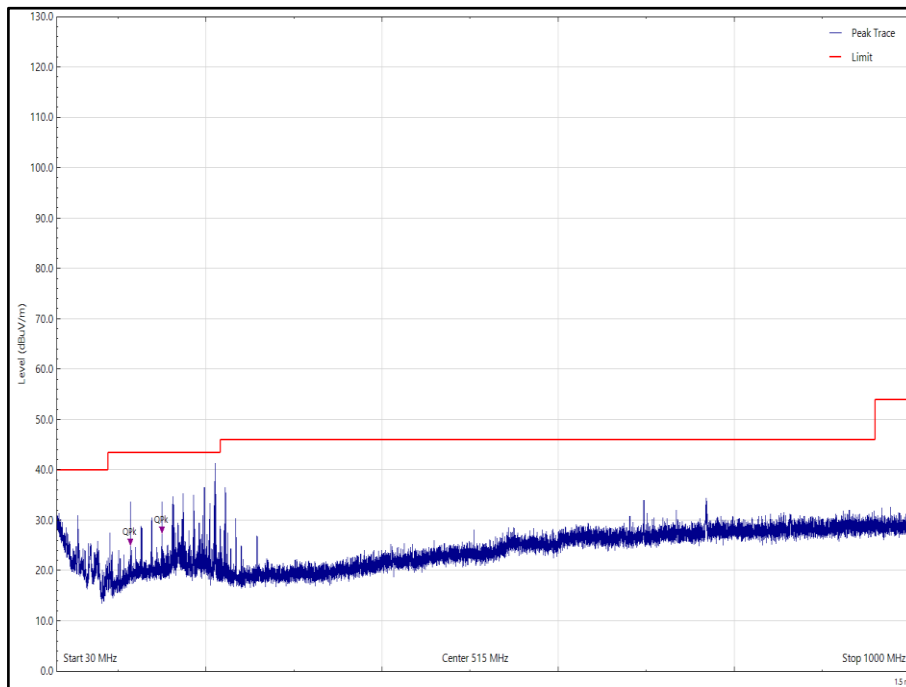

Figure 55 - Proprietary - Z, 2440 MHz, 30 MHz to 1 GHz, Vertical (Peak)

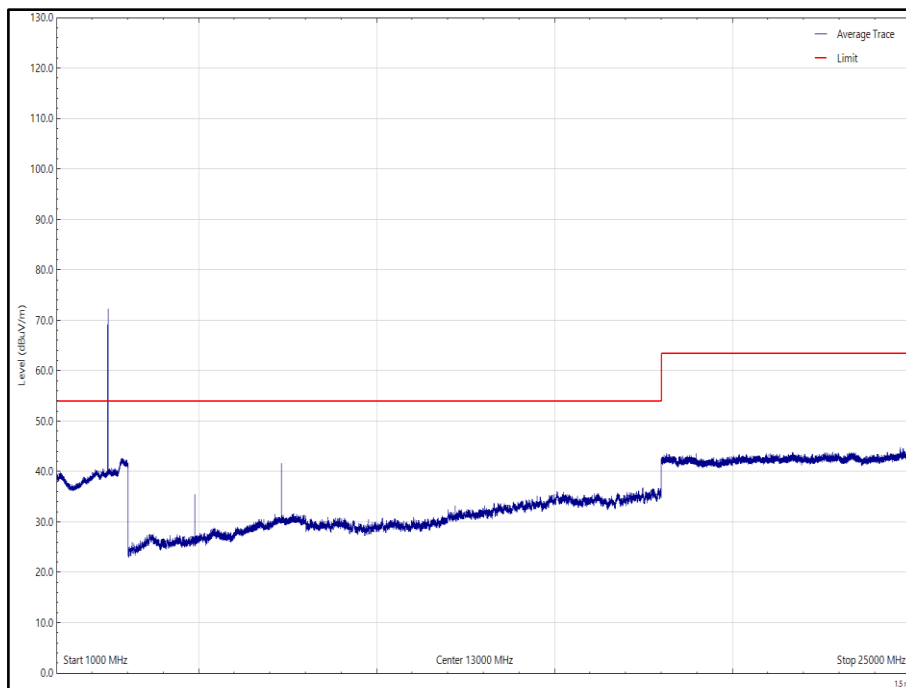

Figure 56 - Proprietary - Z, 2440 MHz, 1 GHz to 25 GHz, Vertical (Average)

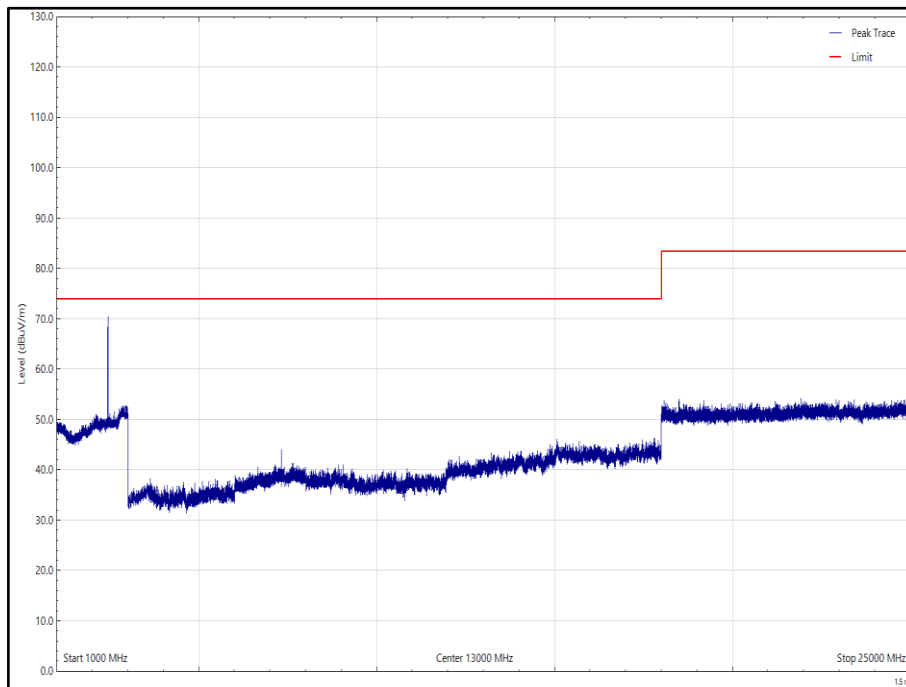

Figure 57 - Proprietary - Z, 2440 MHz, 1 GHz to 25 GHz, Vertical (Peak)



Frequency (MHz)	Level (dBuV/m)	Limit (dBuV/m)	Margin (dB)	Detector	Angle (°)	Height (cm)	Polarisation
149.722	25.7	43.5	-17.9	Q-Peak	259	107	Vertical

Table 34 - Proprietary - Z, 2480 MHz, 30 MHz to 25 GHz

No other emissions found within 10 dB of the limit.

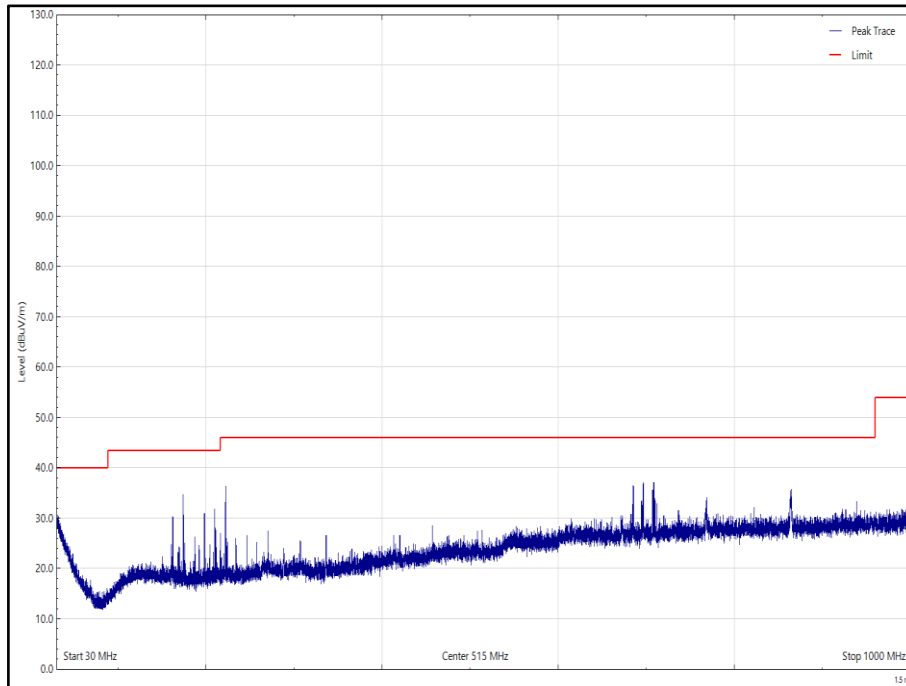

Figure 58 - Proprietary - Z, 2480 MHz, 30 MHz to 1 GHz, Horizontal (Peak)

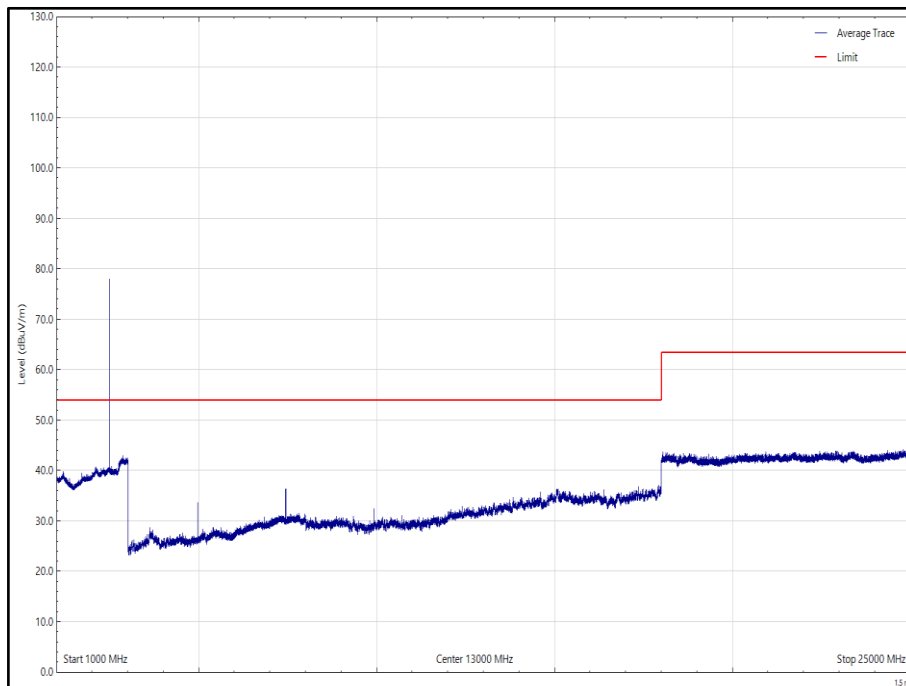

Figure 59 - Proprietary - Z, 2480 MHz, 1 GHz to 25 GHz, Horizontal (Average)

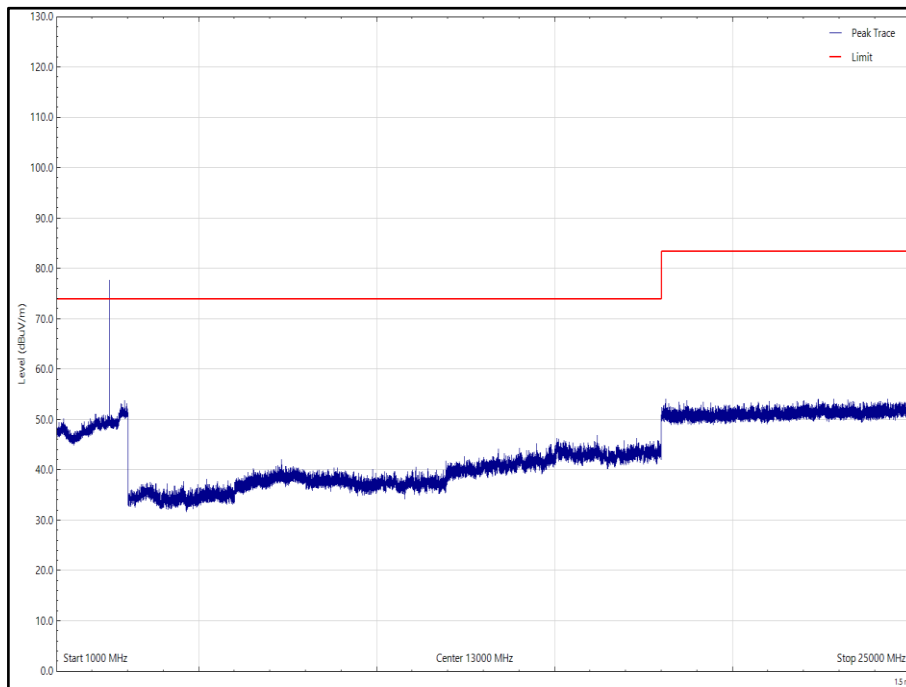

Figure 60 - Proprietary - Z, 2480 MHz, 1 GHz to 25 GHz, Horizontal (Peak)

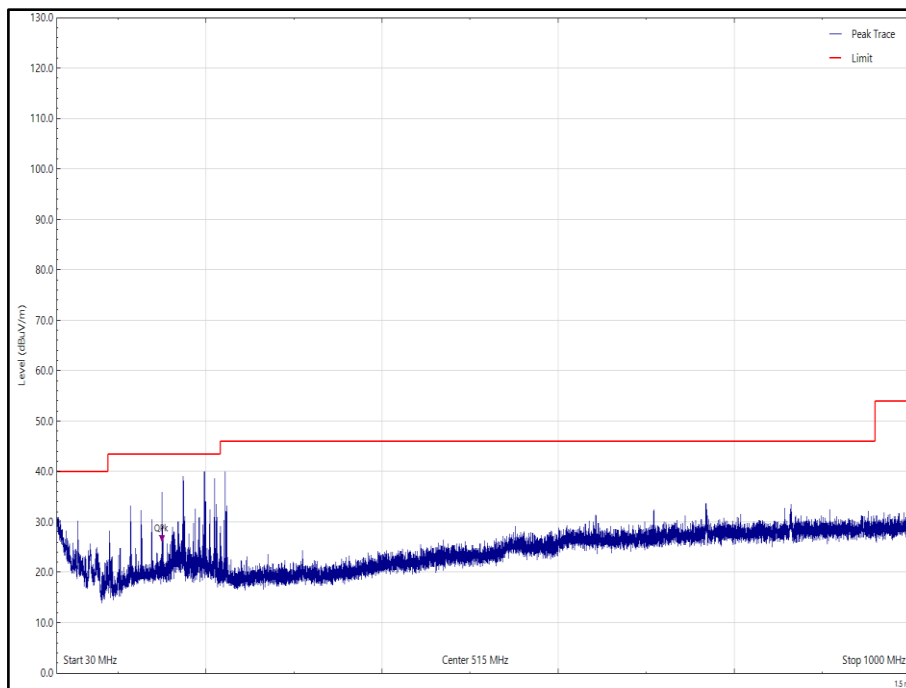

Figure 61 - Proprietary - Z, 2480 MHz, 30 MHz to 1 GHz, Vertical (Peak)

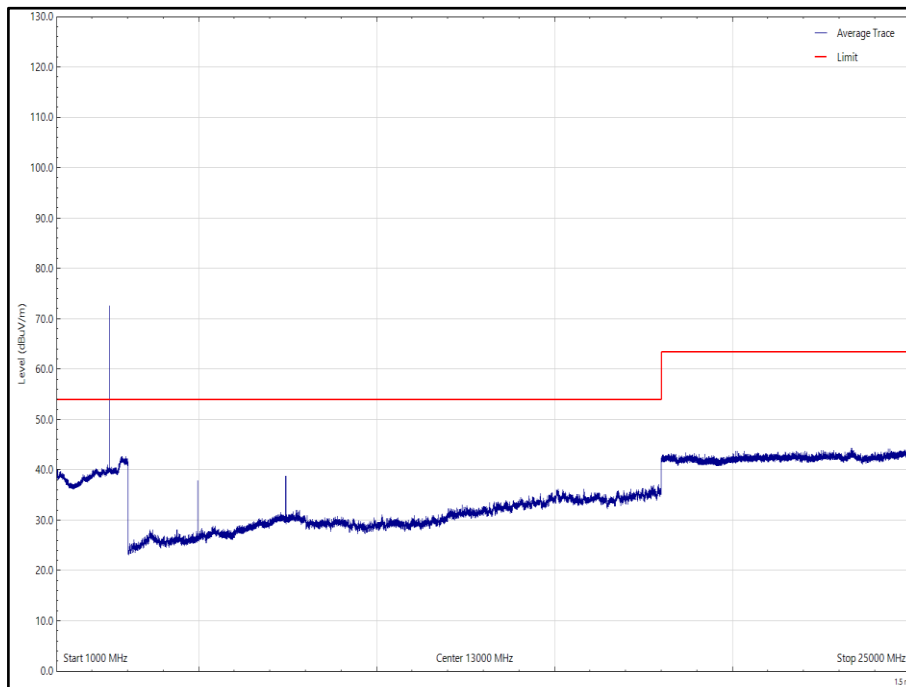

Figure 62 - Proprietary - Z, 2480 MHz, 1 GHz to 25 GHz, Vertical (Average)

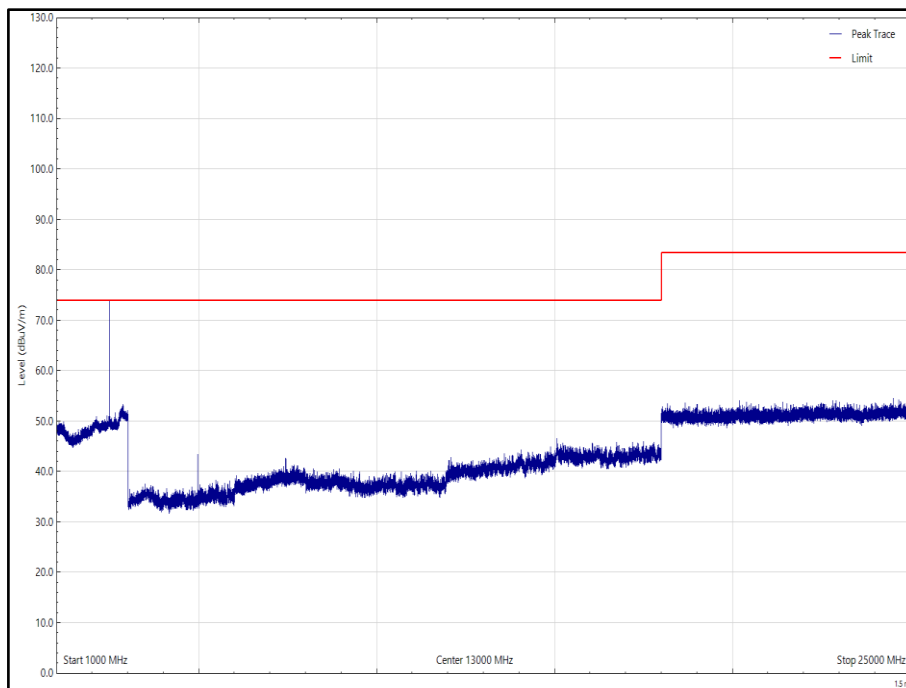

Figure 63 - Proprietary - Z, 2480 MHz, 1 GHz to 25 GHz, Vertical (Peak)



FCC 47 CFR Part 15, Limit Clause 15.247 (d)

In any 100 kHz bandwidth outside the frequency band in which the spread spectrum or digitally modulated intentional radiator is operating, the radio frequency power that is produced by the intentional radiator shall be at least 20 dB below that in the 100 kHz bandwidth within the band that contains the highest level of the desired power, based on either an RF conducted or a radiated measurement, provided the transmitter demonstrates compliance with the peak conducted power limits. If the transmitter complies with the conducted power limits based on the use of RMS averaging over a time interval, as permitted under paragraph (b)(3) of this section, the attenuation required under this paragraph shall be 30 dB instead of 20 dB.

Attenuation below the general limits specified in § 15.209(a) is not required. In addition, radiated emissions which fall in the restricted bands, as defined in § 15.205(a), must also comply with the radiated emission limits specified in 15.209(a)

ISED RSS-247, Limit Clause 5.5

In any 100 kHz bandwidth outside the frequency band in which the spread spectrum or digitally modulated device is operating, the RF power that is produced shall be at least 20 dB below that in the 100 kHz bandwidth within the band that contains the highest level of the desired power, based on either an RF conducted or a radiated measurement, provided that the transmitter demonstrates compliance with the peak conducted power limits. If the transmitter complies with the conducted power limits based on the use of root-mean-square averaging over a time interval, as permitted under Section 5.4(4), the attenuation required shall be 30 dB instead of 20 dB. Attenuation below the general field strength limits specified in RSS-Gen is not required.

In addition, radiated emissions which fall in the restricted bands, as defined in RSS-GEN, clause 8.10, must also comply with the radiated emission limits specified in RSS-GEN clause 8.9.



2.4.8 Test Location and Test Equipment Used

This test was carried out in EMC Chamber 12.

Instrument	Manufacturer	Type No	TE No	Calibration Period (months)	Calibration Expires
Antenna 18-40GHz (Double Ridge Guide)	Link Microtek Ltd	AM180HA-K-TU2	230	24	27-Jul-2022
Antenna with attenuator (Bilog, 30 MHz to 3 GHz)	Schaffner	CBL6143	287	24	14-Oct-2022
Pre-Amplifier, (8 GHz to 18 GHz)	Phase One	PS04-0086	1533	12	05-Feb-2022
18GHz - 40GHz Pre-Amplifier	Phase One	PSO4-0087	1534	12	02-Aug-2022
Comb Generator	Schaffner	RSG1000	3034	-	TU
Multimeter	Fluke	79 Series II	3057	12	23-Aug-2022
Test Receiver	Rohde & Schwarz	ESU40	3506	12	18-Mar-2022
Cable 1503 2M 2.92(P)m 2.92(P)m	Rhophase	KPS-1503A-2000-KPS	4293	12	16-Nov-2021
Cable (K-Type to K-Type, 2 m)	Scott Cables	KPS-1501-2000-KPS	4526	6	06-Mar-2022
Cable (N-Type to N-Type, 1 m)	Rosenberger	LU7-036-1000	5031	12	23-Jul-2022
EmX Emissions Software	TUV SUD	V2.1.11	5125	-	Software
Pre-Amplifier (30 dB, 1 GHz to 18 GHz)	Schwarzbeck	BBV 9718 C	5350	12	22-Sep-2022
Cable (N-Type to N-Type, 8 m)	Teledyne	PR90-088-8MTR	5450	6	08-Mar-2022
Thermo-Hygro-Barometer	PCE Instruments	PCE-THB-40	5481	12	31-Mar-2022
Cable (K-Type to K-Type, 1 m)	Junkosha	MWX241-01000KMSKMS/A	5511	12	09-Apr-2022
1m K-Type Cable	Junkosha	MWX241-01000KMSKMS/A	5512	12	09-Apr-2022
2m K Type Cable	Junkosha	MWX241-02000KMSKMS/A	5524	12	24-Mar-2022
3 GHz High pass Filter	Wainwright	WHKX12-2580-3000-18000-80SS	5548	12	07-May-2022
DRG Horn Antenna (7.5-18GHz)	Schwarzbeck	HWRD750	5610	12	15-Oct-2022
Antenna (DRG, 1 GHz to 10 GHz)	Schwarzbeck	BBHA 9120 B	5611	12	15-Oct-2022
Turntable & Mast Controller	Maturo Gmbh	NCD/498/2799.01	5612	-	TU
Tilt Antenna Mast	Maturo Gmbh	TAM 4.0-P	5613	-	TU
Turntable	Maturo Gmbh	Turntable 1.5 SI-2t	5614	-	TU
Screened Room (12)	MVG	EMC-3	5621	36	11-Aug-2023

Table 35

TU - Traceability Unscheduled



2.5 Authorised Band Edges

2.5.1 Specification Reference

FCC 47 CFR Part 15C, Clause 15.247 (d)
ISED RSS-247, Clause 5.5

2.5.2 Equipment Under Test and Modification State

Atom Controller, S/N: Not serialised (Storix-ID 599374-98) - Modification State 0

2.5.3 Date of Test

26-October-2021

2.5.4 Test Method

The test was performed in accordance with ANSI C63.10, clause 6.10.4.

2.5.5 Environmental Conditions

Ambient Temperature	26.2 °C
Relative Humidity	41.7 %



2.5.6 Test Results

2.4 GHz proprietary device

Mode	Frequency (MHz)	Band Edge Frequency (MHz)	Level (dBc)
Static	2402	2400.0	-36.09
Static	2480	2483.5	-33.78

Table 36

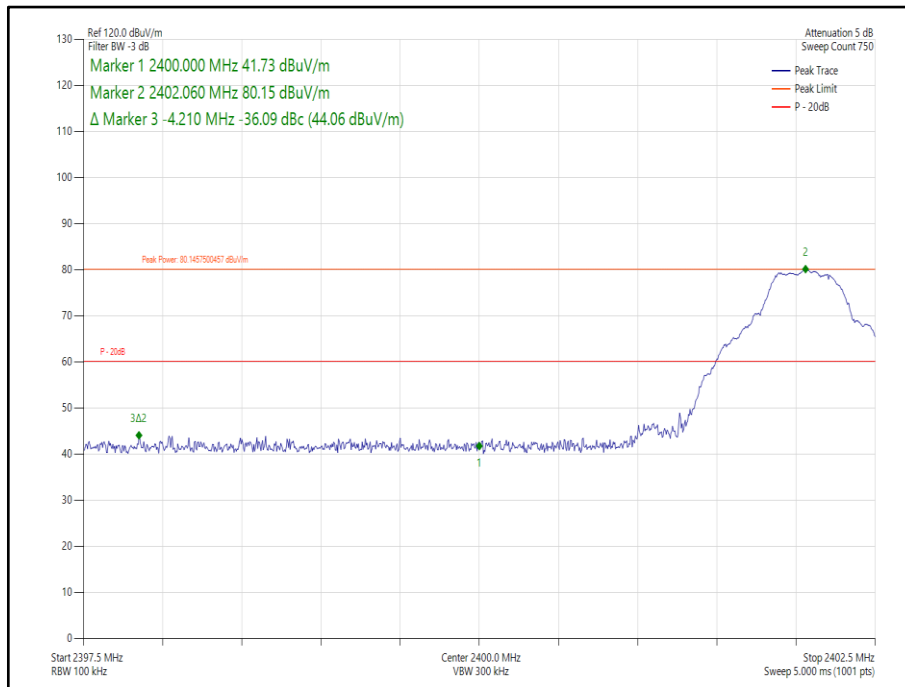

Figure 64 - Proprietary, 2402 MHz, Band Edge Frequency 2400 MHz

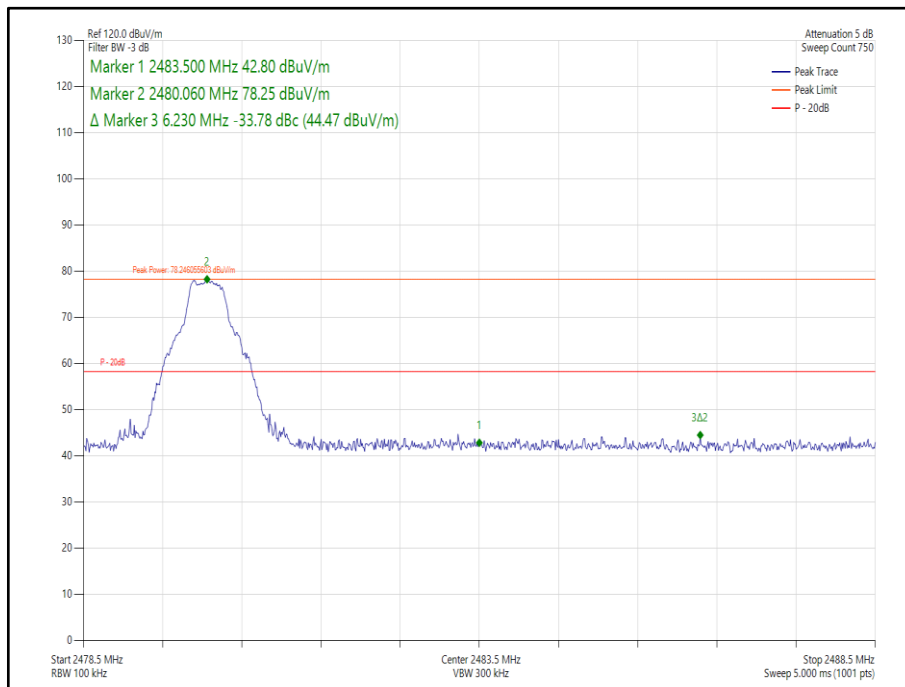

Figure 65 - Proprietary, 2480 MHz, Band Edge Frequency 2483.5 MHz



FCC 47 CFR Part 15, Limit Clause 15.247 (d)

20 dB below the fundamental measured in a 100 kHz bandwidth using a peak detector. If the transmitter complies with the conducted power limits, based on the use of RMS averaging over a time interval, the attenuation required shall be 30 dB below the fundamental instead of 20 dB.

ISED RSS-247, Limit Clause 5.5

In any 100 kHz bandwidth outside the frequency band in which the spread spectrum or digitally modulated device is operating, the RF power that is produced shall be at least 20 dB below that in the 100 kHz bandwidth within the band that contains the highest level of the desired power, based on either an RF conducted or a radiated measurement, provided that the transmitter demonstrates compliance with the peak conducted power limits. If the transmitter complies with the conducted power limits based on the use of root-mean-square averaging over a time interval, as permitted under Section 5.4(4), the attenuation required shall be 30 dB instead of 20 dB. Attenuation below the general field strength limits specified in RSS-Gen is not required.

2.5.7 Test Location and Test Equipment Used

This test was carried out in EMC Chamber 12.

Instrument	Manufacturer	Type No	TE No	Calibration Period (months)	Calibration Expires
Test Receiver	Rohde & Schwarz	ESU40	3506	12	18-Mar-2022
Cable (K-Type to K-Type, 2 m)	Scott Cables	KPS-1501-2000-KPS	4526	6	06-Mar-2022
EmX Emissions Software	TUV SUD	V2.1.11	5125	-	Software
Cable (N-Type to N-Type, 8 m)	Teledyne	PR90-088-8MTR	5450	6	08-Mar-2022
Thermo-Hygro-Barometer	PCE Instruments	PCE-THB-40	5481	12	31-Mar-2022
Antenna (DRG, 1 GHz to 10 GHz)	Schwarzbeck	BBHA 9120 B	5611	12	15-Oct-2022
Turntable & Mast Controller	Maturo Gmbh	NCD/498/2799.01	5612	-	TU
Tilt Antenna Mast	Maturo Gmbh	TAM 4.0-P	5613	-	TU
Turntable	Maturo Gmbh	Turntable 1.5 SI-2t	5614	-	TU
Screened Room (12)	MVG	EMC-3	5621	36	11-Aug-2023

Table 37

TU - Traceability Unscheduled



2.6 Power Spectral Density

2.6.1 Specification Reference

FCC 47 CFR Part 15C, Clause 15.247 (e)
ISED RSS-247, Clause 5.2
ISED RSS-GEN, Clause 6.12

2.6.2 Equipment Under Test and Modification State

Atom Controller, S/N: Not serialised (Storix-ID 599374-119) - Modification State 0

2.6.3 Date of Test

08-October-2021

2.6.4 Test Method

This test was performed in accordance with ANSI C63.10, clause 11.10.5.

2.6.5 Environmental Conditions

Ambient Temperature	20.8 °C
Relative Humidity	56.5 %



2.6.6 Test Results

2.4 GHz proprietary device

Test Configuration			
Frequency Range:	2400-2483.5 MHz	Band:	2.4 GHz
Limit Clause(s):	15.247 (e) RSS-247 5.2 b)	Test Method(s):	C63.10 11.10.5
Additional Reference(s):	-		
Note(s):	DCCF was added to the spectrum analyser reference level offset.		

DUT Configuration			
Mode:	Proprietary ISM	Duty Cycle (%):	23.2
Data Rate:	-	DCCF (dB):	6.35
Antenna Configuration:	SISO	Peak Antenna Gain (dBi):	-
Active Port(s):	1	Active Chain(s):	0

Test Frequency (MHz)	RBW (kHz)	PSD (dBm/RBW)					Limit (dBm/3 kHz)	Margin (dB)
		A	B	C	D	Σ		
2402	3.0	-14.71	-	-	-	-	8.00	-22.71
2442	3.0	-16.23	-	-	-	-	8.00	-24.23
2480	3.0	-16.26	-	-	-	-	8.00	-24.26

Table 38 - Maximum Power Spectral Density Results

FCC 47 CFR Part 15, Limit Clause 15.247 (e)

The power spectral density conducted from the intentional radiator to the antenna shall not be greater than 8 dBm in any 3 kHz band during any time interval of continuous transmission.

ISED RSS-247, Limit Clause 5.2(b)

The transmitter power spectral density conducted from the transmitter to the antenna shall not be greater than 8 dBm in any 3 kHz band during any time interval of continuous transmission



2.6.7 Test Location and Test Equipment Used

This test was carried out in RF Laboratory 1.

Instrument	Manufacturer	Type No	TE No	Calibration Period (months)	Calibration Expires
Rubidium Standard	Rohde & Schwarz	XSRM	1316	6	03-Dec-2021
Hygrometer	Rotronic	I-1000	3220	12	16-Oct-2021
Frequency Standard	Spectracom	SecureSync 1200-0408-0601	4393	6	03-Dec-2021
Climatic Chamber	Aralab	FitoTerm 300E45	4823	12	12-Apr-2022
MXA Signal Analyser	Keysight Technologies	N9020B	5528	24	04-Mar-2022
Signal Commissioning Unit	TUV SUD	SCU001	5546	12	16-Apr-2022

Table 39

3 Photographs

3.1 Test Setup Photographs



Figure 66 - Test Setup - 30 MHz to 1 GHz - X Orientation

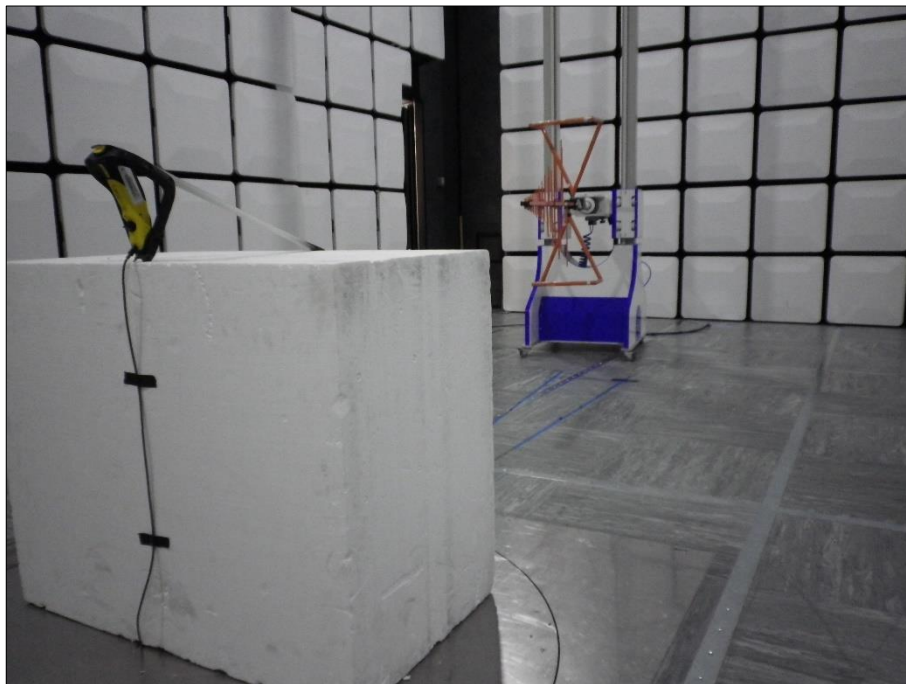

Figure 67 - Test Setup - 30 MHz to 1 GHz - Y Orientation

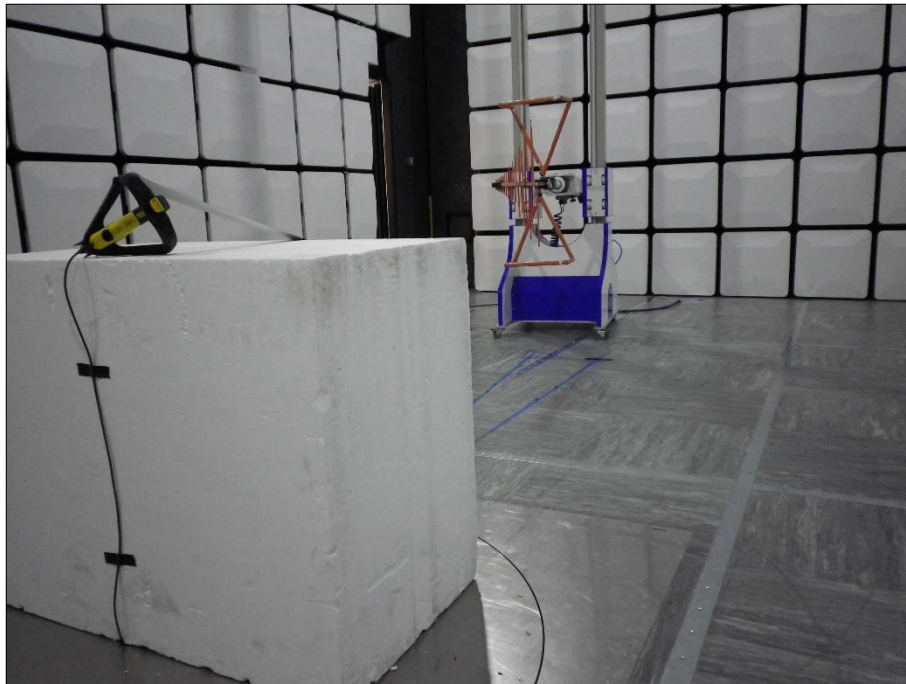

Figure 68 - Test Setup - 30 MHz to 1 GHz - Z Orientation

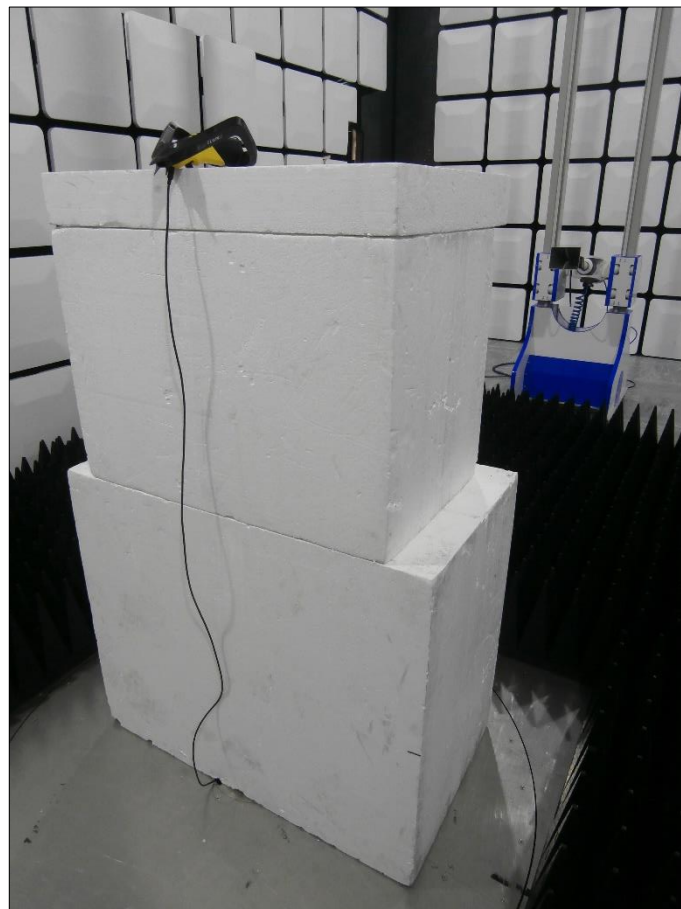

Figure 69 - Test Setup - 1 GHz to 18 GHz - X Orientation



Figure 70 - Test Setup - 1 GHz to 18 GHz - Y Orientation

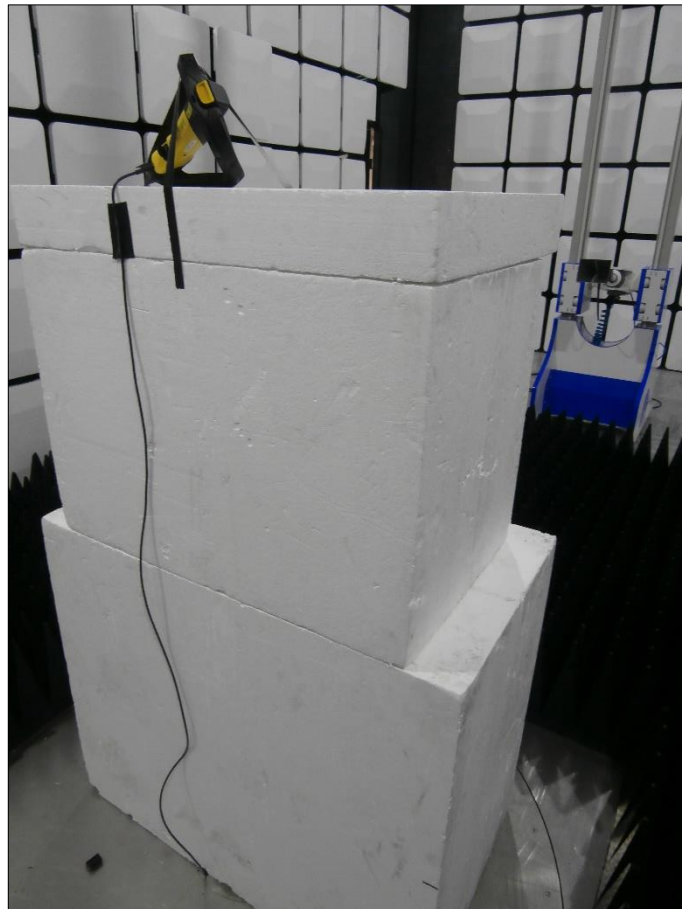

Figure 71 - Test Setup - 1 GHz to 18 GHz - Z Orientation



Figure 72 - Test Setup - 18 GHz to 25 GHz - X Orientation



Figure 73 - Test Setup - 18 GHz to 25 GHz - Y Orientation



Figure 74 - Test Setup - 18 GHz to 25 GHz - Z Orientation



4 Measurement Uncertainty

For a 95% confidence level, the measurement uncertainties for defined systems are:

Test Name	Measurement Uncertainty
Restricted Band Edges	30 MHz to 1 GHz: ± 5.2 dB 1 GHz to 40 GHz: ± 6.3 dB
Emission Bandwidth	± 25.354 kHz
Maximum Conducted Output Power	± 3.2 dB
Spurious Radiated Emissions	30 MHz to 1 GHz: ± 5.2 dB 1 GHz to 40 GHz: ± 6.3 dB
Authorised Band Edges	30 MHz to 1 GHz: ± 5.2 dB 1 GHz to 40 GHz: ± 6.3 dB
Power Spectral Density	± 3.2 dB

Table 40

Measurement Uncertainty Decision Rule

Determination of conformity with the specification limits is based on the decision rule according to IEC Guide 115:2007, Clause 4.4.3 and 4.5.1. (Procedure 2). The measurement results are directly compared with the test limit to determine conformance with the requirements of the standard.
 Risk: The uncertainty of measurement about the measured result is negligible with regard to the final pass/fail decision. The measurement result can be directly compared with the test limit to determine conformance with the requirement (compare IEC Guide 115). The level of risk to falsely accept and falsely reject items is further described in ILAC-G8.