

# iHome

## AUTO VAC

### NOVA S2

**Scan the QR code located on top of your  
iHome AutoVac for a guided setup.**

Watch the setup video, get the iHome Clean app, activate your warranty, purchase accessories, get support and more!

NOTE: QR code is also included on the bottom of the robot for your convenience.

**Owner's Guide**  
Model iHRVS2-3BLK



## TABLE OF CONTENTS

1 - 2	Safety
3	In The Box
4	Product Overview
5	Dustbin Overview
6	Robot Indicators
7	Setting up the Charging Dock
8	Setting Up The AutoVac Nova S2
9	Using the iHOME CLEAN App
10 - 11	Using Your AutoVac
12	Using the Remote
13 - 15	Using Powermop Scrub
16	Main Brush Maintenance
17	Maintaining the Dustbin, Filters and Mop
18	Side Brush and Sensor Maintenance
19	AutoVac Nova S2 Troubleshoot
20	Warranty

## SAFETY DEFINITIONS

▲ **WARNING:** Indicates a hazardous situation that, if not avoided, could result in death or serious injury.

▲ **CAUTION:** Indicates a hazardous situation that, if not avoided, could result in minor or moderate injury.

▲ **NOTICE:** Indicates a hazardous situation that, if not avoided, could result in property damage.

Before using this product, please read the following safety instructions and follow all safety precautions. Any operation inconsistent with this instruction manual may cause damage to this product.

### ▲ **WARNING:**

- Your robot is not a toy. Small children and pets should be supervised when your robot is operating.
- Do not sit or stand on your robot.
- Do not use unauthorized chargers. Use of an unauthorized charger could cause the battery to generate heat, smoke, catch fire or explode. Contact customer service for a replacement charger.
- Do not open your robot except as instructed to install or replace the battery or maintain the dustbin and filter(s). Do not open the charging dock as there are no user serviceable parts inside.
- Risk of electric shock. Only use indoors and in dry locations.
- Do not handle your robot with wet hands.
- Store and operate your robot in room temperature environments only.
- Do not operate the robot in areas with exposed electrical outlets in the floor.
- Do not attempt to open, crush or heat the battery of your robot above 175°F.
- Do not subject the battery to mechanical shock.
- Do not short circuit the battery of your robot by allowing any metal objects to contact the battery terminal.
- Do not immerse the battery in liquid.
- Do not attempt to charge damaged or leaking battery packs. If battery leakage occurs, thoroughly wash any affected skin, making sure to keep battery acid away from eyes, ears, nose and mouth. Immediately wash any clothing or other surface that comes in contact with leaked battery acid. If a chemical burn occurs or if irritation persists, seek medical attention. Dispose according to Local, State or Federal regulations.

### ▲ **CAUTION:**

- If the robot passes over a power cord there is a chance an object can be pulled off a table. Before using the robot, clear the floor of objects such as clothing, cords for blinds and curtains. Power cords and any fragile objects which can be easily damaged.
- Do not use the robot to pick up sharp objects, or anything that is burning or smoking.

**▲ NOTICE:**

- This robot is intended for dry floor use only. Do not use the robot to pick up any wet spills and do not allow the dustbin contents to become wet.
- Do not place anything on top of your robot.
- Regularly wipe charge contacts on your robot and charge dock. Failure to maintain charge contacts could impact the robots ability to properly charge.
- Product may not be used with any type of power converter. Use of power converters will void the warranty.
- The battery pack must be removed from the robot before recycling or disposal.
- Do not use non-rechargeable batteries in your robot. For battery replacement contact customer care.
- Before long term storage of your robot, fully charge and remove the battery.

## IN THE BOX

3

1: Charging Dock  
2: AutoVac Nova S2

3: Charging Adapter  
4: Sidebrush

5: HEPA Filter (installed)  
6: Cleaning Tool

7: Remote  
8: Powermop Scrub Attachment

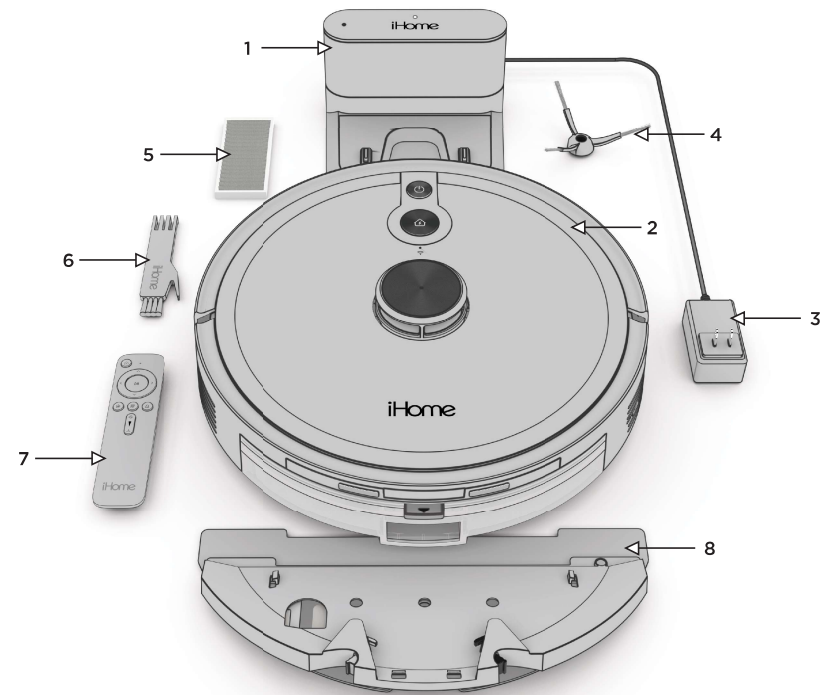

**FRONT**

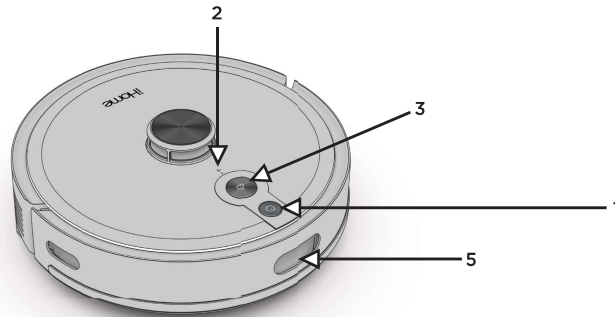

**BACK**

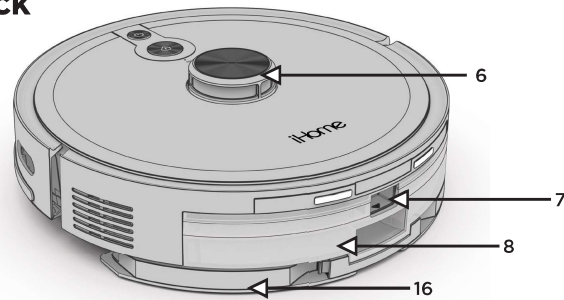

**CHARGING BASE**

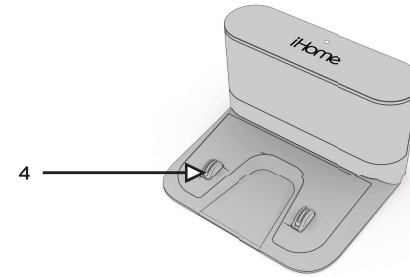

**BOTTOM**

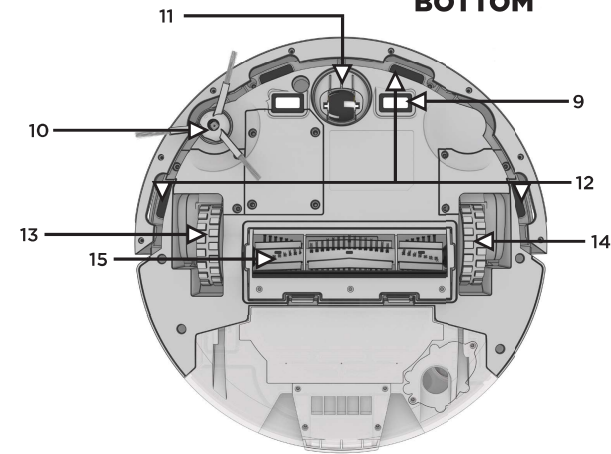

- 1: Power Button
- 2: WiFi Indicator
- 3: Home Button
- 4: Charging Contacts

- 5: Navigation Sensors
- 6: 360° LIDAR Module
- 7: Dustbin Release Latch
- 8: Dustbin

- 9: Charging Contacts
- 10: Side Brush
- 11: Omnidirectional Wheel
- 12: Detection Sensors

- 13: Left Wheel
- 14: Right Wheel
- 15: Main Brush
- 16: Powermop Scrub Attachment

## DUSTBIN OVERVIEW

5

1: Bin/Filter Release Latch

2: HEPA Filter

3: Foam Filter

4: Screen Filter

5: Powermop Scrub Attachment

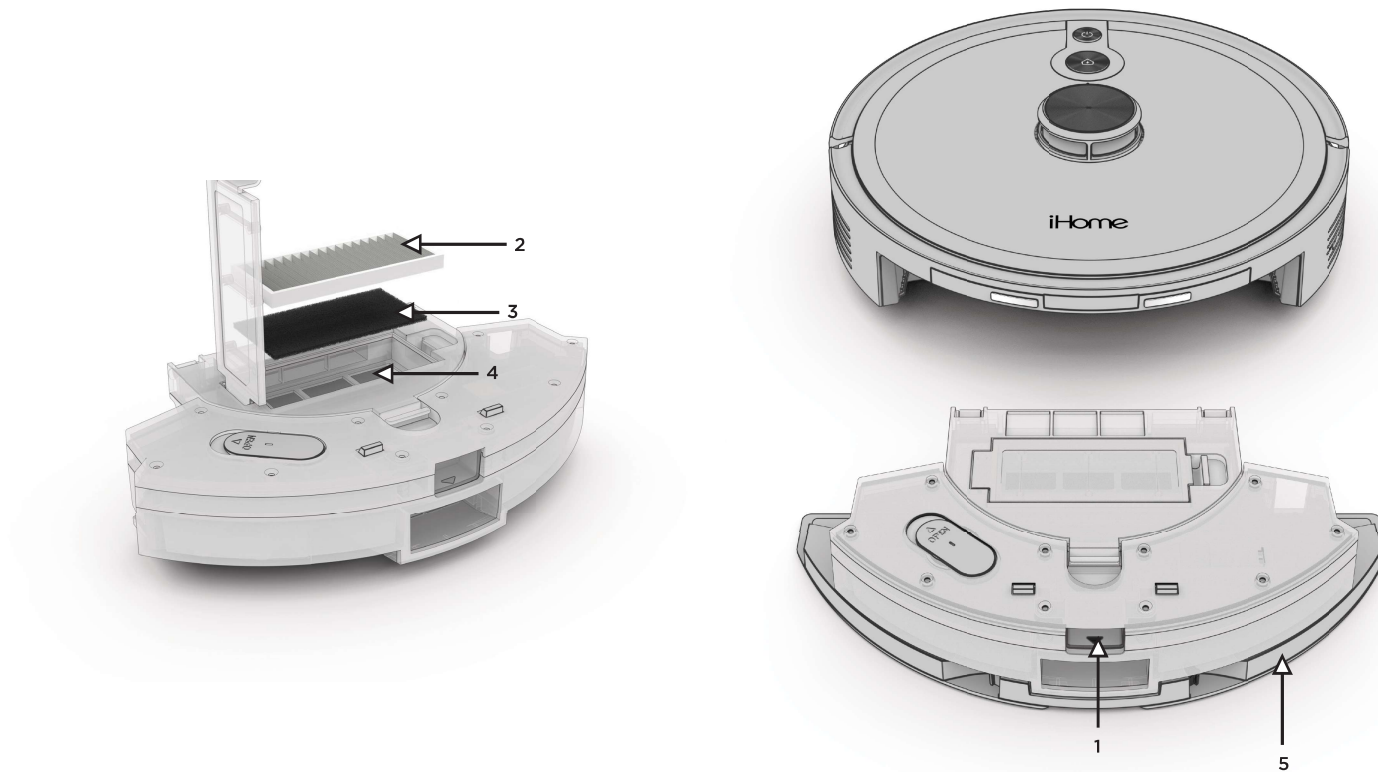

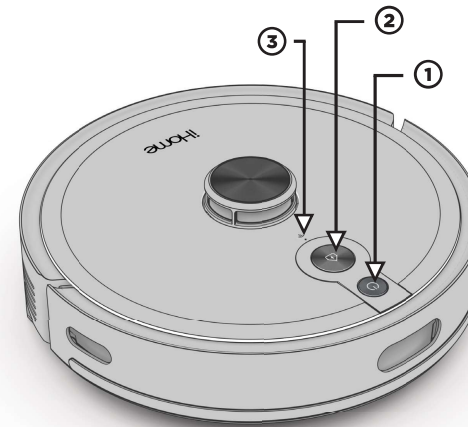
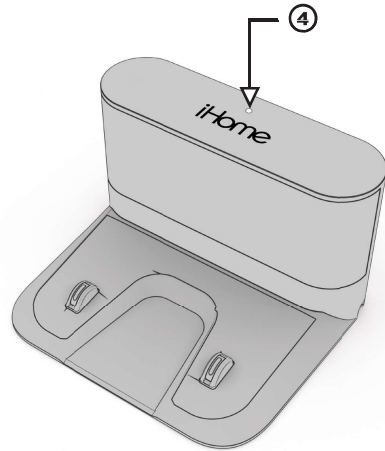

### ① POWER BUTTON

- Hold to turn on/off
- Press to start/pause cleaning

### ② HOME BUTTON

- Press to return to charging dock for recharging
- Press and Hold to initiate Wifi Setup

### ③ WIFI INDICATOR

### ④ CHARGING INDICATOR

### POWER/HOME LED STATES

- Blinking Blue: Standby Mode
- Solid Blue (OFF Charge Base): Cleaning
- Solid Green (ON Charge Base): Fully Charged
- Breathing Green: Charging
- Fast Blink Red: Error
- Lights off: Off/sleeping

### WIFI INDICATOR STATES

- Blinking White: Network Configuration Mode
- Solid White: Wifi connected
- Light Off: Wifi disconnected / Network configuration failure

### CHARGING INDICATOR LED STATES

- Will remain lit Blue when connected to power



### ABOUT YOUR CHARGING DOCK

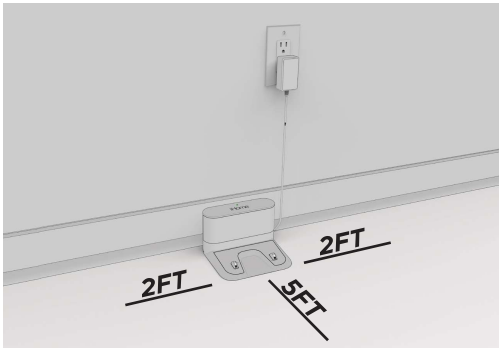

Place the charging dock against the wall and make sure the place is an open & uncluttered area. Leaving at least 5 feet in front of the charging dock and 2 feet on both sides of the charging dock.

**NOTE:** Clearance around the charging base is necessary to prevent obstructions when the Vacuum returns to charge. Avoid using a power source that may inadvertently be switched off (e.g. power strip, outlet controlled by a light switch, GFCI).

### SETTING UP THE CHARGING DOCK

- 1 Plug the power adapter into the port on the bottom of the charging dock and secure the cable into the channel.

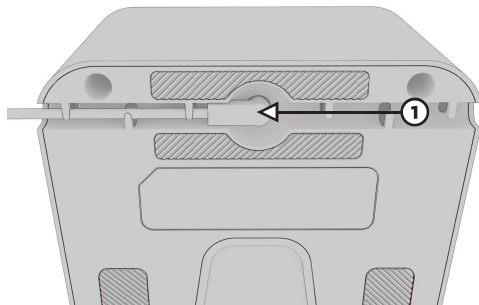

- 2 Choose a location on a hard floor surface near a power outlet. Place the charging dock against the wall as shown. Plug the power adapter into a functioning wall outlet.

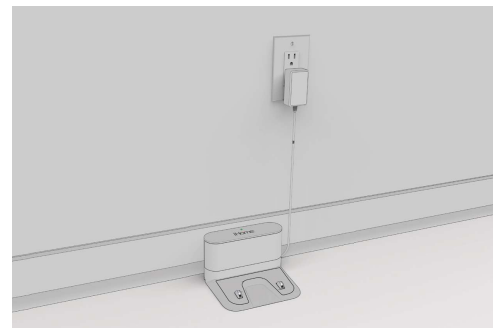

## SETTING UP THE AUTOVAC NOVA S2

8

### STEP 1

Install the side brush by pushing firmly down until it clicks into place.

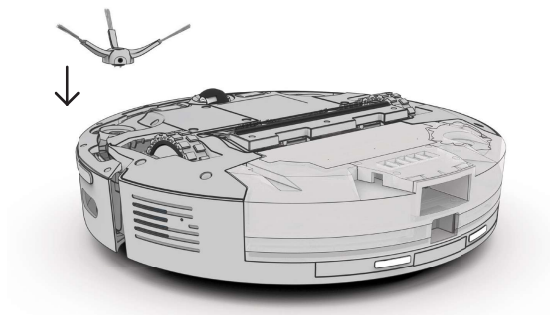

### STEP 2

Position the Vacuum on the floor near your charge dock as shown. To turn on Press and Hold the Power button until the indicator turns blue.

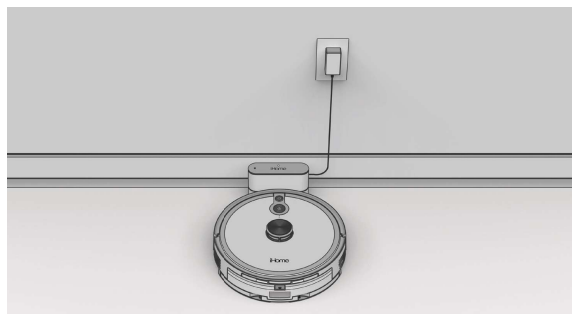
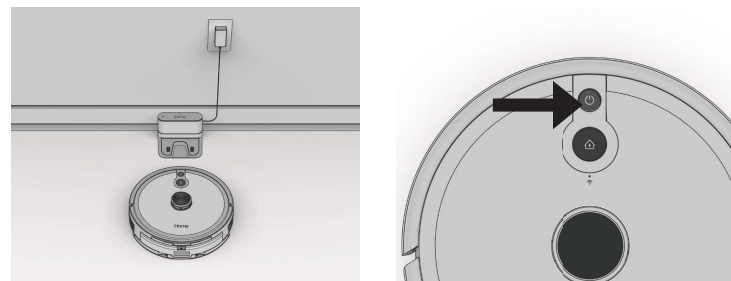

**NOTE:** Allow your Vacuum to fully charge (up to 5 hours) before first use. The indicators on your robot will turn solid green when fully charged.

### STEP 3

Press the  button to pair Nova S2 to your Charge Base. Nova S2 will navigate and dock to the base for charging.

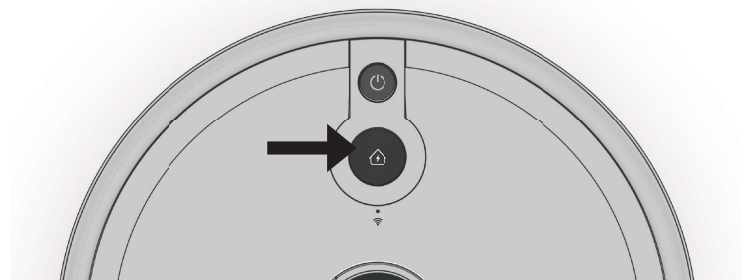

### UNDERSTANDING YOUR VACUUM

Your iHome Autovac is designed to automatically and intelligently clean your home, Nova S2 uses advanced laser scanning technology and multiple sensors to form a navigational map, Nova S2 will continue to clean until it has determined that the addressable floor area has been covered. The navigational map is available to view in the iHome Clean app and is updated during each clean cycle to ensure that your Autovac takes any changes (moved furniture or other obstructions) into account. Once cleaning is finished the Nova S2 will automatically return to the charge base.

### DOWNLOAD THE IHOME CLEAN APP

- Search "iHome Clean" in the App Store or use the QR code below:



**NOTE:** Connecting your Vacuum to Wi-Fi is not required but highly recommended. Using the Home app, you can follow the steps to connect your Vacuum to Wi-Fi. The app will let you manage your Vacuum from anywhere, set cleaning schedules, view cleaning history, access support and more!

---

The iHome Clean app provides an easy step by step guide to get your Vacuum connected to Wi-Fi. Here is a checklist of what you'll need before getting started:

- An iPhone (iOS 10 or later) OR Android (4.4 or later).
- Make sure that your phone is connected to your desired Wi-Fi Network. This will be the network that your AutoVac Nova S2 connects to.
- Your Wi-Fi network must be a 2.4Ghz network (5Ghz networks are not supported).
- Download and launch the iHome Clean app from the app store. Create a user account.
- Follow the steps in the app to add the Vacuum.

## PREPPING YOUR HOME



Simply press the Power button on your Nova S2 to begin an Auto-Clean cycle of your home. Your Autovac will start cleaning and will continue until it has covered the entire cleaning area. It's important to allow the Autovac to fully complete its cleaning cycle in order to ensure it is able to map out your complete floorplan (viewable in the iHome Clean app). Once cleaning is finished, the Nova S2 will automatically return to the charge base.

Use the iHome Clean App to set Areas and Boundaries in your map for customized cleaning options.

### FOLLOW THE STEPS BELOW

**NOTE:** Before starting your first cleaning cycle please clear the floor of all objects other than furniture as some small objects may obstruct, get caught in, or damage the iHome Autovac Nova S2.

## FIRST CLEANING AND MAPPING

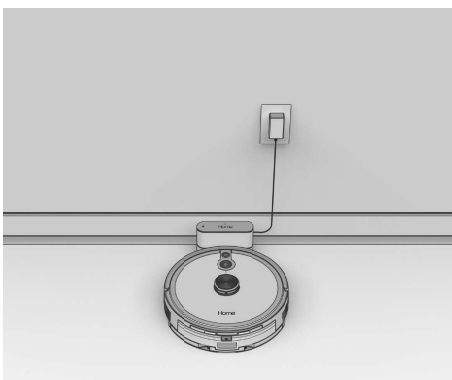

1 Ensure your AutoVac is on the charging base and fully charged.

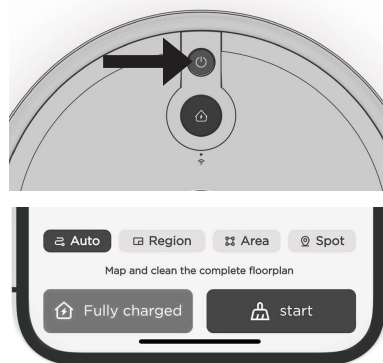

2 Start an Auto Clean cycle by pressing 'POWER' on your AutoVac or by choosing 'START' in the iHome Clean app.

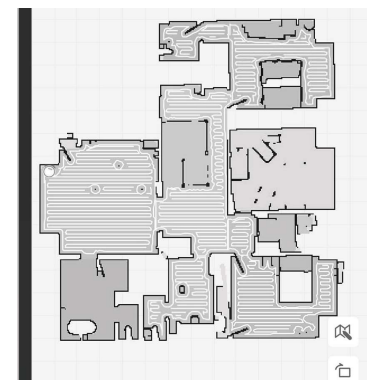

3 When the cleaning is complete, your home map will be visible in the iHome Clean app.

### CLEANING MODES

**Auto Clean** - The Nova S2 will automatically clean your floor until it has covered the entire surface. Once cleaning is finished the Nova S2 will automatically return back to the Charge Base to empty the dustbin and re-charge.

**Area Clean** - Draw customizable areas in your floor-plan within the iHome Clean App. The Nova S2 can then be sent to your desired Area.

**Spot Clean** - The Nova S2 will deep clean a specific spot. First, use the manual navigation control to guide your Nova S2 to the desired location. Then, choose Spot Clean mode for a deep clean.

**Edge Clean** - The Nova S2 will clean along your baseboards.

**Powermop Scrub** - Fill the water tank and connect the Powermop Scrub attachment. Nova S2 will automatically mop and vacuum your floor area. Use the iHome Clean app to specify your desired mop areas and preferences.

**Manual Control** - Using the navigational D-Pad on the remote control (or in the iHome Clean App) you can manually control where the Nova S2 goes to clean.



10 - 20 FT

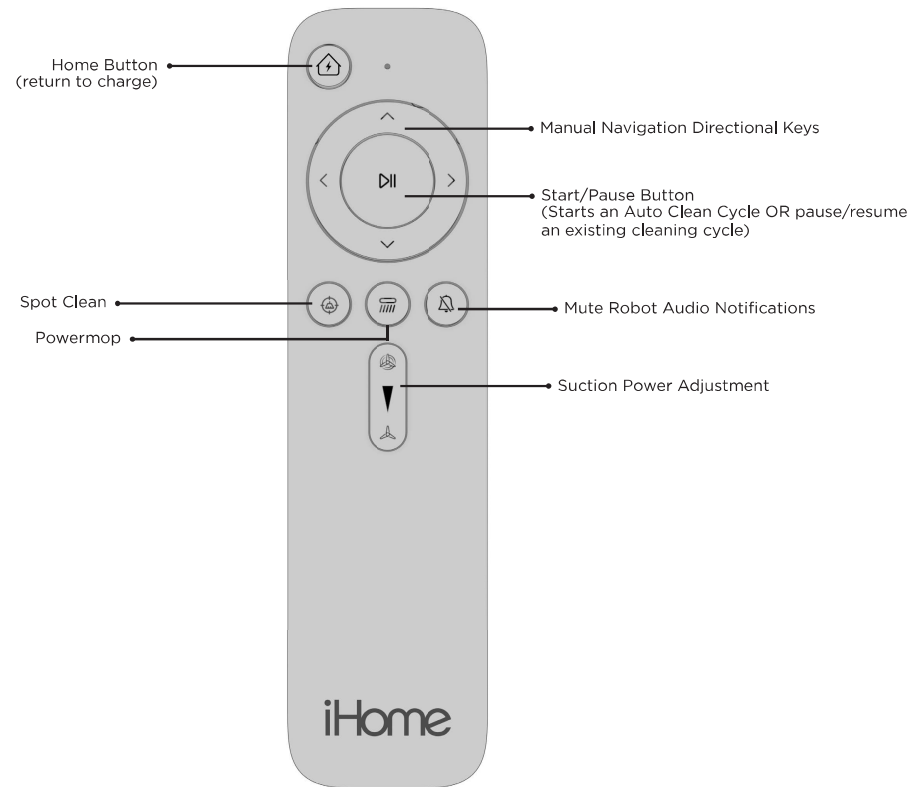

**NOTE:**

- 1: It is recommended to point the remote to the front of the Nova S2 for best results.
- 2: The remote control range is 10 - 20 feet.

Your Autovac comes equipped with a Powermop Scrub mopping attachment that connects to the 2-in-1 Dustbin/Water Tank. Follow the steps below to initiate wet mopping with your Autovac.

---

- 1 Place the mop pad onto the mop attachment and secure it to the velcro strips. Slip corners of the mop pad over the plastic tabs at the rear of the mop attachment.



- 2 Slide mop attachment onto dustbin as shown in figure below until you hear a click confirming that it is locked in place.

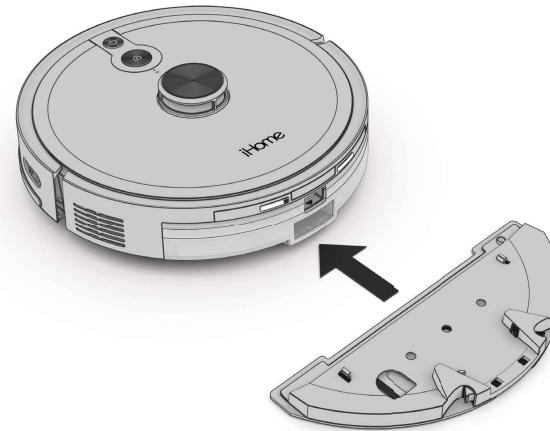

- ③ Remove the dustbin from the Nova S2 with the mop attachment still installed.

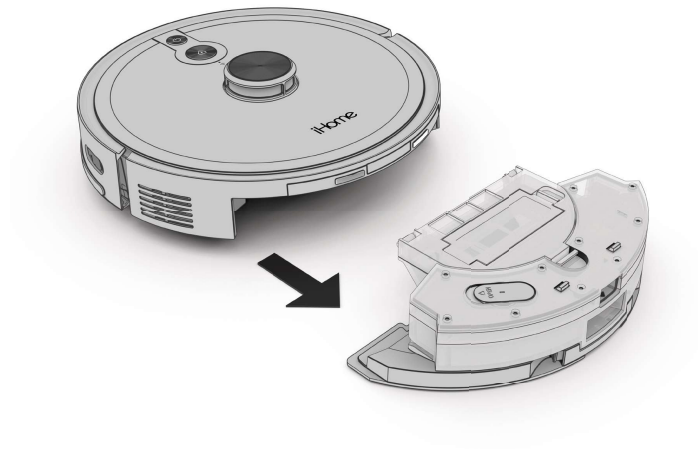

- ④ Open the water fill cap on the dustbin and fill with water, then close the cap. Please ensure that the mop attachment is connected before filling water.

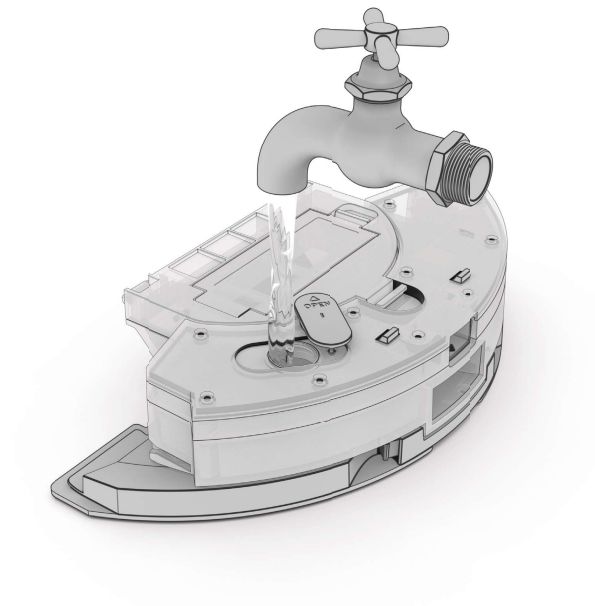



- 5 Install the dustbin with the mop attachment still installed into the Nova S2 according to the figure below.

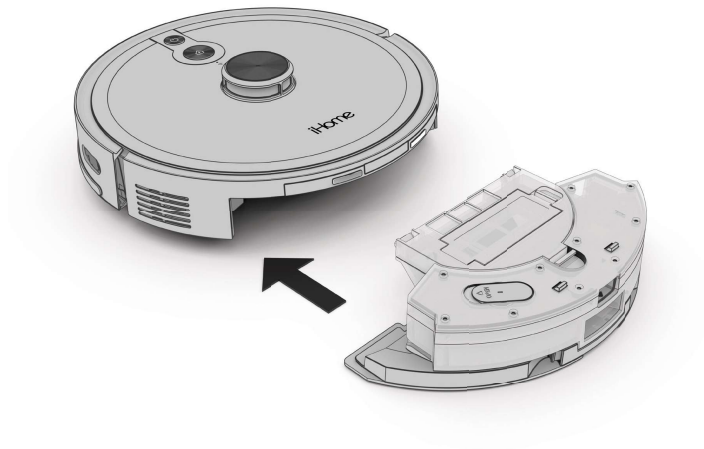

- 6 Activate Powermop Scrub mode in the app or using the remote control.



## MAIN BRUSH MAINTENANCE

16

### ▲ CAUTION:

- Power off the vacuum before performing maintenance.

Your Vacuum is designed to be used regularly. As with most floor care devices, regular use may cause build-up around brushes, in debris compartments and near filters. We recommend performing regular maintenance, as outlined in the following pages, to keep your AutoVac Nova S2 running at optimal performance.

- 1: Pinch the left and right tabs on the main brush cover. Lift and remove the cover.
- 2: Remove the main brush and clean.
- 3: Replace the main brush and snap the cover back into place.

**NOTE:** It is recommended to replace the main brush every 6-12 months depending on use.

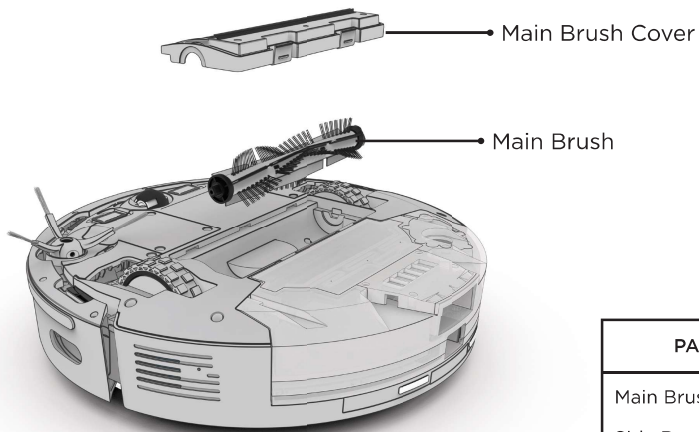

### MAINTENANCE SCHEDULE

PART	CARE FREQUENCY	REPLACEMENT FREQUENCY
Main Brush	Once a month	Replace every 6-12 months
Side Brush	Once a month	Replace every 6-12 months
HEPA Filter	Every 2 Weeks	Replace every 3 months

## MAINTAINING THE DUSTBIN, FILTERS AND MOP

17

- ① Press the dustbin release button and remove the dustbin.

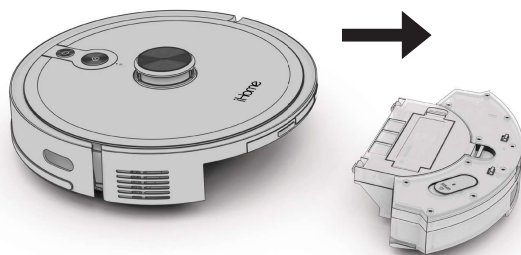

- ② Empty the dustbin contents into the trash and wipe the inside thoroughly with a dry cloth.

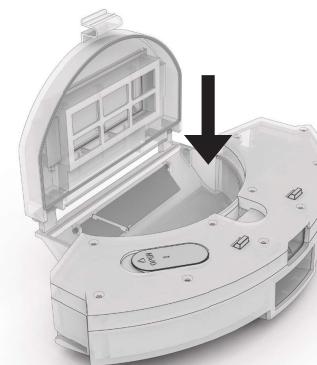

- ③ Remove the sponge filter and HEPA filter. Tap the HEPA filter to dislodge dust. Rinse the sponge filter and wipe down the filter housing with a dry cloth. Allow sponge filter to dry completely before reassembly.

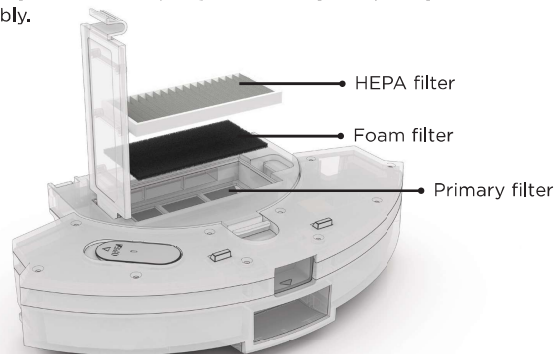

- ④ Remove the mop pad to wash (machine washable).

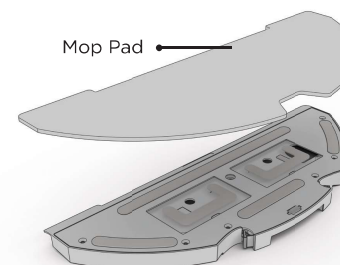

## SIDE BRUSH AND SENSOR MAINTENANCE

18

- 1: Pop off the side brush by pulling it upward.
- 2: Remove dirt and debris and reinstall by pushing down in place.
- 3: It is recommended to wipe dust from the charging pins on your robot and charge dock regularly.

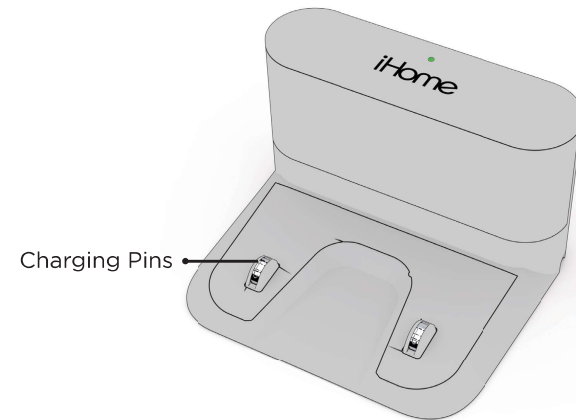
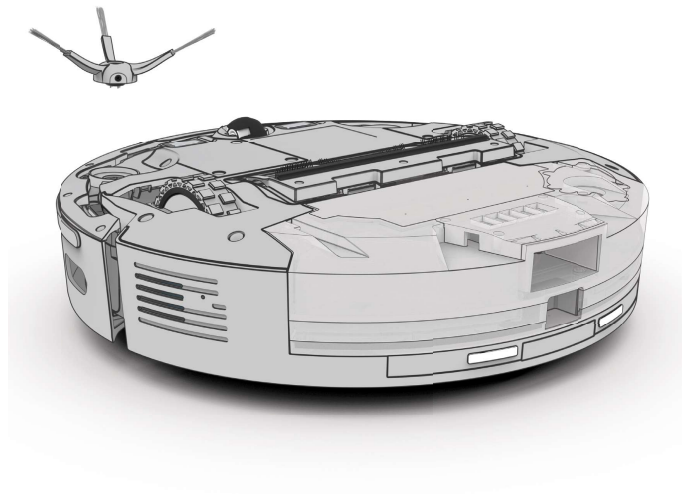

**NOTE:** It is recommended to replace the side brush every 6-12 months depending on use.

---

PROBLEM	SOLUTION
Unable to power on.	Please charge before use. This is commonly caused due to low battery.
Unable to start cleaning..	Please charge before use. This is commonly caused due to low battery.
Unable to return to charging dock.	<ul style="list-style-type: none"> <li>• There are too many obstacles near the charging dock. Please make sure there is a clear area 2 FT of space on either side and 5 FT in front of the charging dock.</li> <li>• Vacuum is out of range of the charging dock. Move the Vacuum closer to the charging dock to re-establish connection.</li> </ul>
Abnormal behavior.	Please make sure the areas to be cleaned are well illuminated. Clean the lens with a clean soft cloth, and make sure the sensor is not blocked. Avoid using any detergent or cleaning spray while cleaning.
Abnormal noise during cleaning.	Main brush, side brush or left/right wheel may be obstructed. Check underneath the Vacuum to make sure it is clear from any obstruction. If there is an obstruction clear it and restart the Vacuum.
Decrease in cleaning ability or dust falling out from dustbin.	<ul style="list-style-type: none"> <li>• The dustbin is full, please empty the dustbin.</li> <li>• Check and clean the HEPA filter.</li> <li>• Check that the brush is clear from obstruction.</li> </ul>
Unable to connect to Wi-Fi.	Wi-Fi signal is not good, please check that there is a strong Wi-Fi connection while pairing. Make sure the network is 2.4G and not 5G or dual band.
Vacuum is not returning to the charging dock after spot cleaning or after moving it far from the charging dock.	After spot cleaning or moving the Vacuum far from the charging dock the Vacuum will re-generate the map. If the Vacuum is far from the charging dock it may not be able to locate it. Please manually dock the Vacuum to the charging dock to recharge.
Unable to charge after docking.	Make sure there is no obstruction or heavy dust on both the Vacuum and charging dock charging contacts.
Scheduled cleaning not working.	Please confirm that the Vacuum is connected to your Wi-Fi network. If the Vacuum is not connected to the network you cannot synchronize the scheduled cleaning task.

The One (1) Year Limited Warranty applies to purchases made from authorized retailers of Silver Point Innovations LLC. Warranty coverage applies to the original owner and to the original product only and is not transferable. We recommend registering your product online at [www.ihomeclean.com](http://www.ihomeclean.com).

SilverPoint warrants this product to be free from defects in workmanship and materials, under normal household use and conditions, one (1) year from the date of original purchase and maintained according to the requirements outlined in this User Manual. Should this product fail to function in a satisfactory manner, it is best to contact our customer service team at 877-370-4580 so that we may help resolve the matter. Should service be required by reason of any defect or malfunction during the warranty period, SilverPoint will repair or, at its discretion, replace the product.

The One (1) Year Limited Warranty is subject to the following conditions and exclusions:

The original unit and/or non-wearable parts deemed defective, in SilverPoint's sole discretion, will be repaired or replaced up to one (1) year from the original purchase date. In the event a replacement unit is issued the replacement product will be warranted for the remainder of the original warranty period or thirty (30) days from the date of shipment of the replacement product, whichever is longer. SilverPoint reserves the right to use new, refurbished or used parts in good working condition to repair or replace any product.

### Exclusions:

- (1) Normal wear and tear of wearable parts (such as batteries, brushes, HEPA filters, pads, etc.), which require regular maintenance and/or replacement to ensure the proper functioning of your unit, are not covered by this warranty. Replacement parts are available for purchase at [www.ihomeclean.com](http://www.ihomeclean.com).
- (2) Any unit that has been tampered with or used for commercial purposes.
- (3) Damage caused by misuse, abuse, negligent handling, failure to perform regular maintenance (i.e., not cleaning the filters), or damage due to mishandling in transit.
- (4) Consequential and incidental damages.
- (5) Defects caused by repair persons not authorized by SilverPoint.
- (6) Products purchased, used, or operated outside of North America.

### Warranty Support:

You must call 877-370-4580 to initiate a warranty claim and have the product on hand during the call. You will need the original receipt as proof of purchase.

The One (1) Year Limited Warranty does not cover the cost of shipping this product to our service center or its return to the owner. Please call Customer Service at 877-370-4580 to evaluate your product and receive warranty term instructions.

**Disclaimer:** This warranty is valid only in the United States of America and does not extend to owners of the product other than to the original purchaser. In no event will SilverPoint or any of its affiliates, contractors, resellers, their officers, directors, shareholders, members or agents be liable to you or any third party for any consequential or incidental damages, any lost profits, actual, exemplary or punitive damages. (Some states do not allow limitations on implied warranties or exclusion of consequential damages, so these restrictions may not apply to you.) This warranty gives you specific legal rights, and you may also have other rights which vary from state to state. Your acknowledgement and agreement to fully and completely abide by this disclaimer of warranty is contractually binding to you upon your transfer of currency (money order, cashier's check, or credit card) for purchase of your SilverPoint product.

Any Changes expressly or modifications not approved by the party responsible for compliance could void the user's authority to operate the equipment.

This device complies with part 15 of the FCC Rules. Operation is subject to the following two conditions:

(1) This device may not cause harmful interference,  
and (2) this device must accept any interference received, including interference that may cause undesired operation.

Note: This equipment has been tested and found to comply with the limits for a Class B digital device, pursuant to part 15 of the FCC Rules. These limits are designed to provide reasonable protection against harmful interference in a residential installation. This equipment generates, uses and can radiate radio frequency energy and, if not installed and used in accordance with the instructions, may cause harmful interference to radio communications. However, there is no guarantee that interference will not occur in a particular installation. If this equipment does cause harmful interference to radio or television reception, which can be determined by turning the equipment off and on, the user is encouraged to try to correct the interference by one or more of the following measures:

- Reorient or relocate the receiving antenna.
- Increase the separation between the equipment and receiver.
- Connect the equipment into an outlet on a circuit different from that to which the receiver is connected.
- Consult the dealer or an experienced radio/TV technician for help.

FCC Radiation Exposure Statement:

This equipment complies with FCC radiation exposure limits set forth for an uncontrolled environment .

This transmitter must not be co-located or operating in conjunction with any other antenna or transmitter.

This equipment should be installed and operated with minimum distance 20cm between the radiator &you body.